

Bauwelt Award

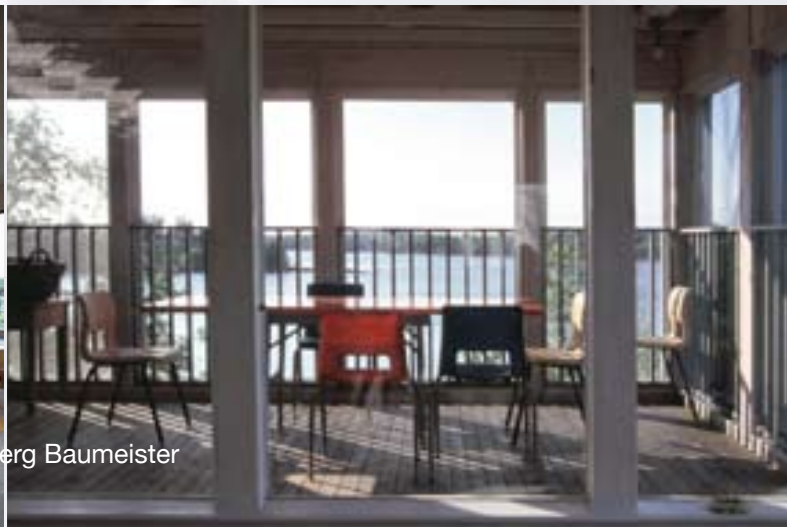

SW296 (first project of Baumeister Architekten): Cottage, N.S, Canada. Living and Sleeping Houses and a linking Active Wall



German Urban Design Award

New Marketplace Fulda, Germany: Business centre and 30 age-appropriate apartments around a new marketplace, shaped by merging two historic layers



First Prizes and Awards (Schinkel-Award)

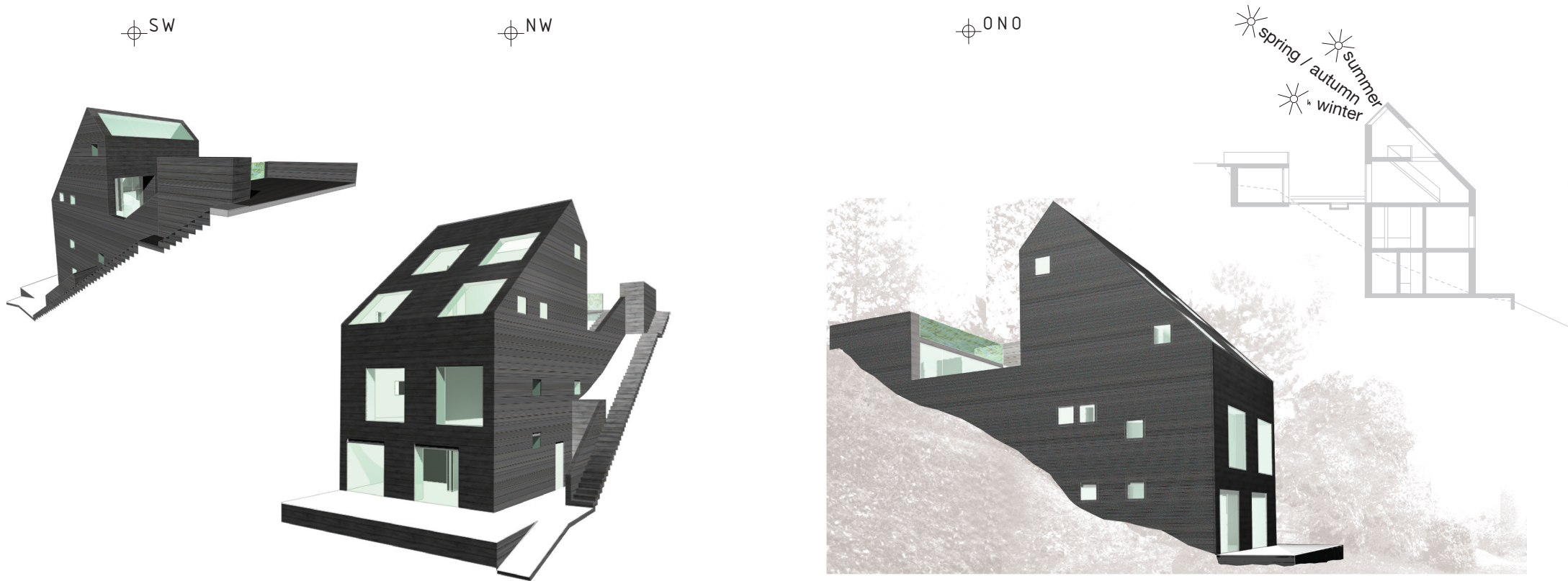

OS29 close to Stuttgart, Germany on a north-facing steep hillside shaped to catch a maximum amount of sunlight

Masterplans on different scales



Headquarters of the African Union (AU)
Upgrading of the existing territory and expansion with new buildings, which are arranged around three central squares (1-3)

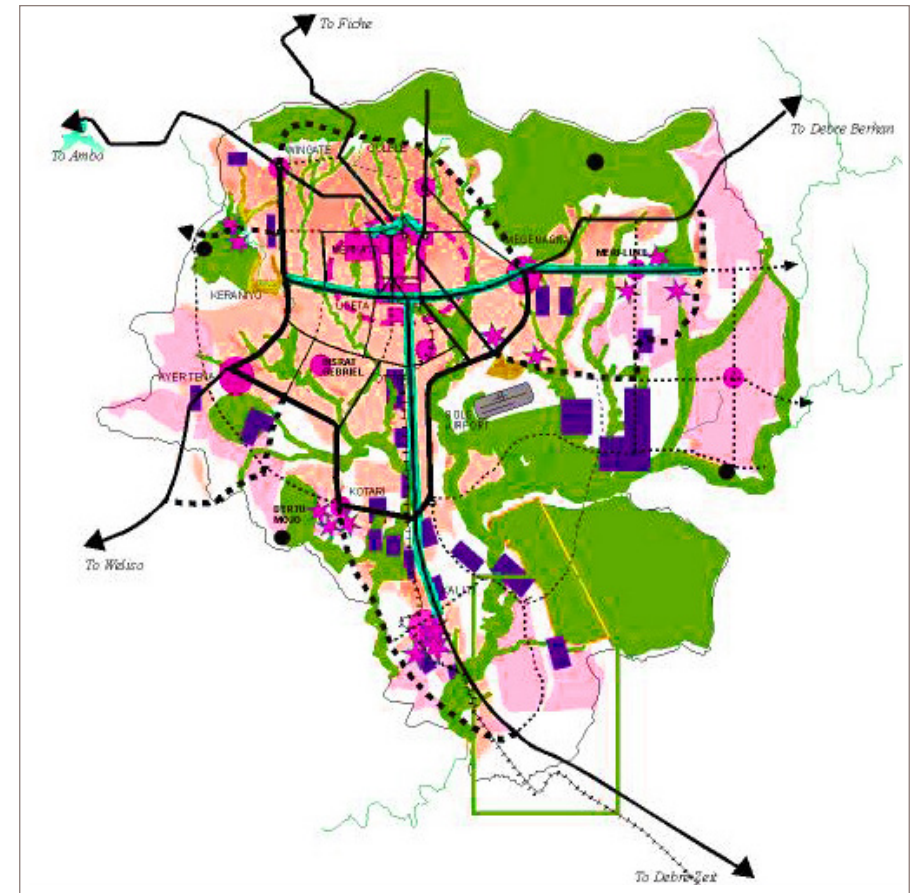

Urban Development Plan, Addis Ababa
Growth strategy and height regulations for a city with rapid population growth (5 -15 Mio) in poverty but with strong communities

(Re-) Development Plans



Mutrah Souq redevelopment

Upgrading the infrastructure and introducing integrated development zones for Sultanate of Oman's main tourism destination

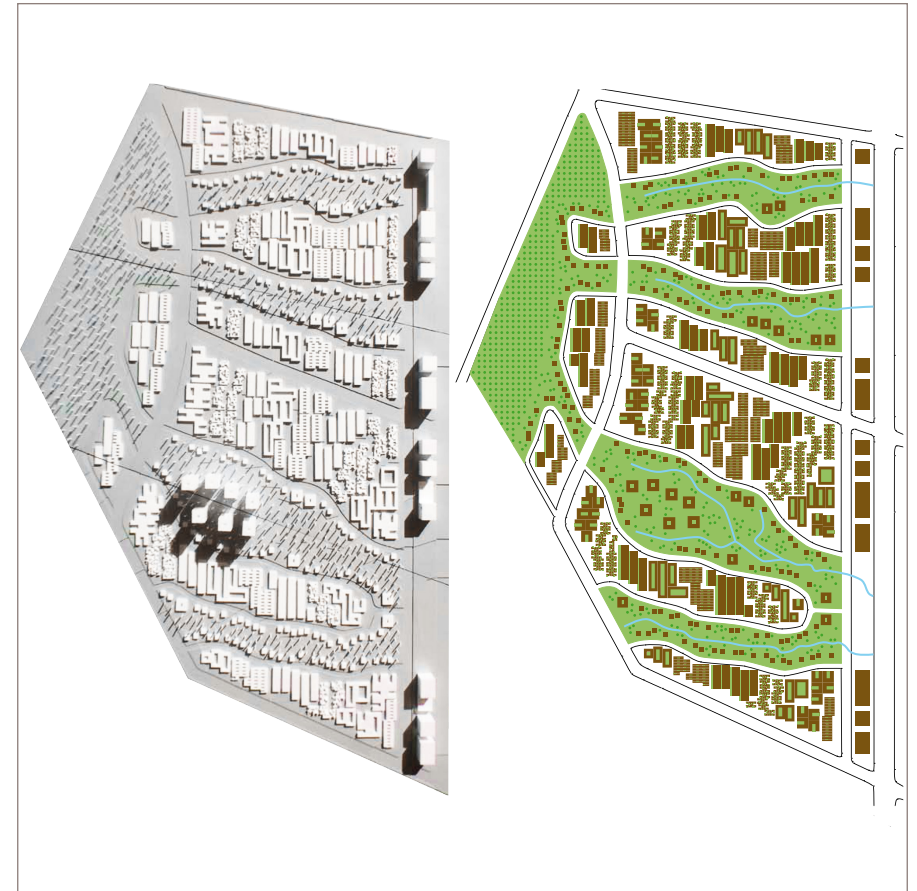

Yeka Hyatt: A new home for 40,000 dwellers

Organically embedded into the physical (topography, local materials) and socio-economic (local communities) environment

Self-help Prototypes



Capacity building for affordable housing in Africa with local materials for better environments, communities, and income

The concept has been progressed and implemented by several colleagues from EiABC (Dirk Hebel, Elias Yitbarek, Dirk Donath etc.), ETH Zuerich, MIT, and additional Universities and has been supported by many NGOs and private donators

© Joerg Baumeister 2020

Self-Sustainable Systems

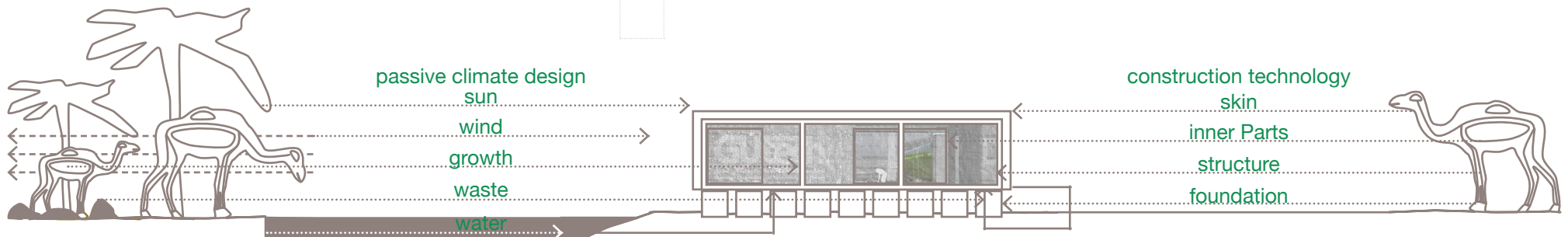
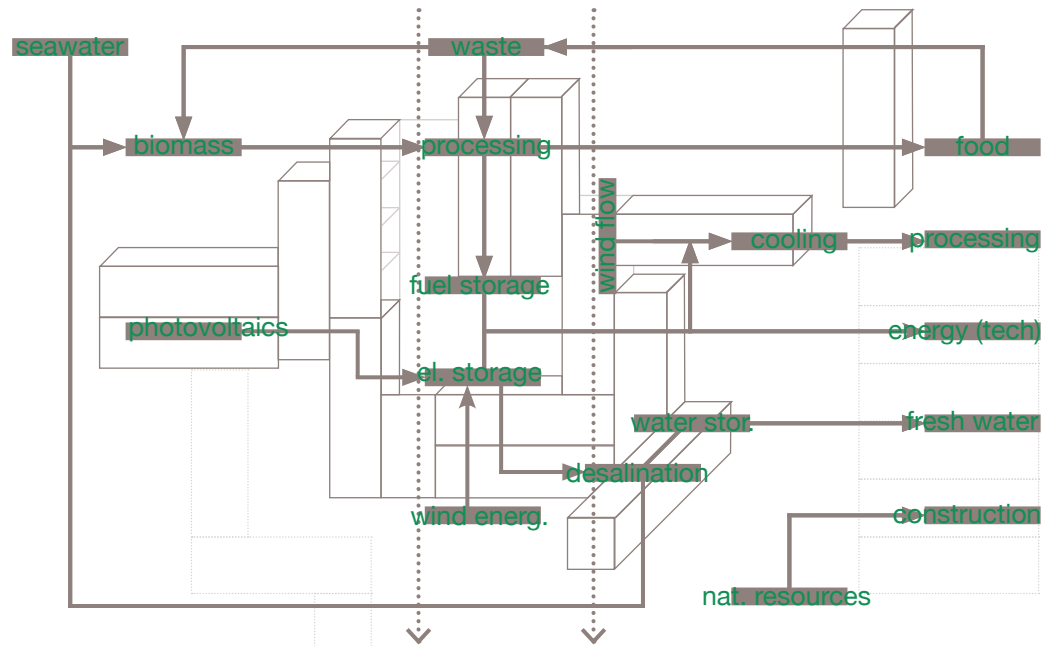

From natural to artificial oasis (Desert Beach Lab, Oman): a building as experiment to find out how to create enclosed ecological systems in a harsh environment and how to optimise the interface between natural methods and technology

Create-your-own public habitat

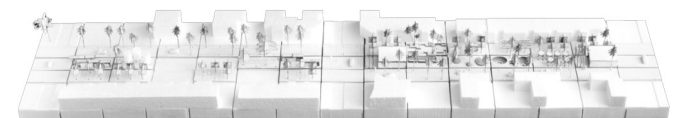
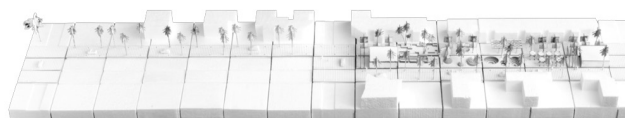
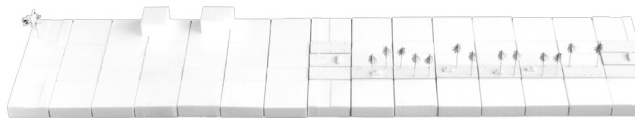
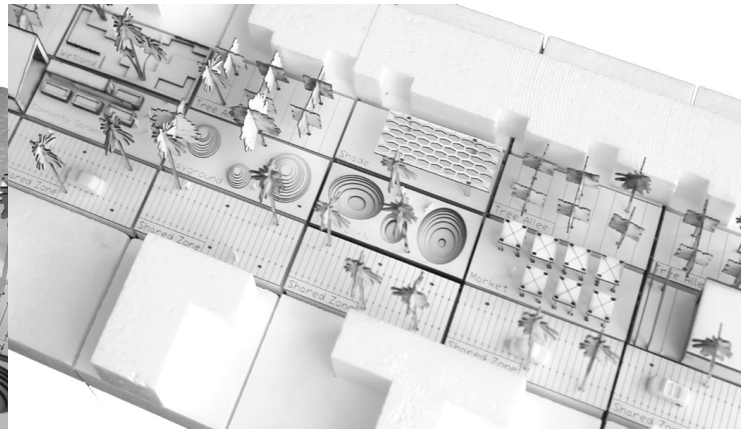
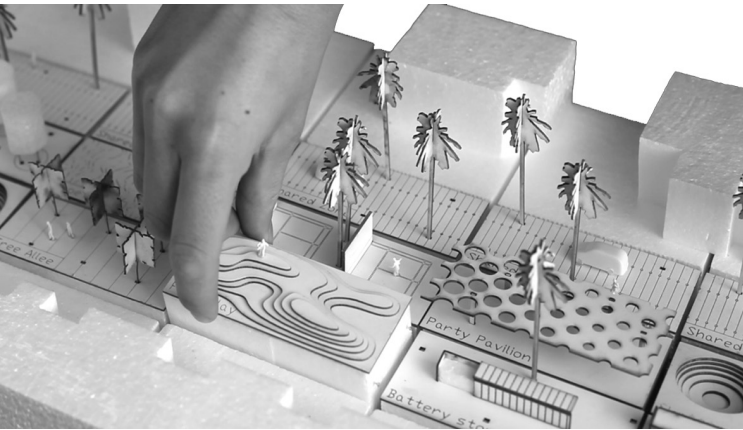

A street more than a street - Instead, a park like no other... incubating the area's unique creative culture and sense of place

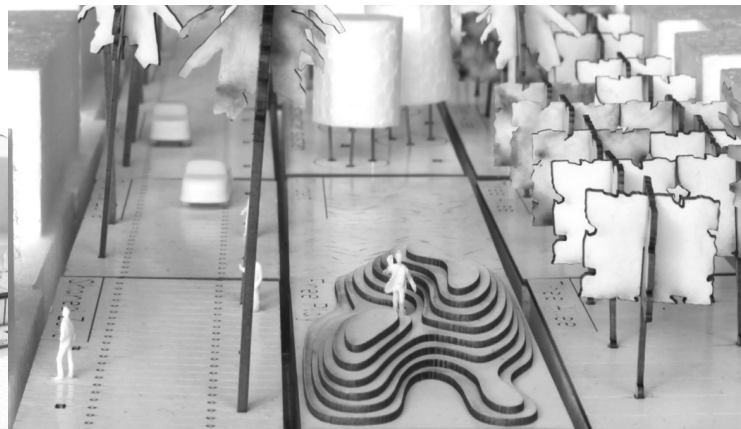
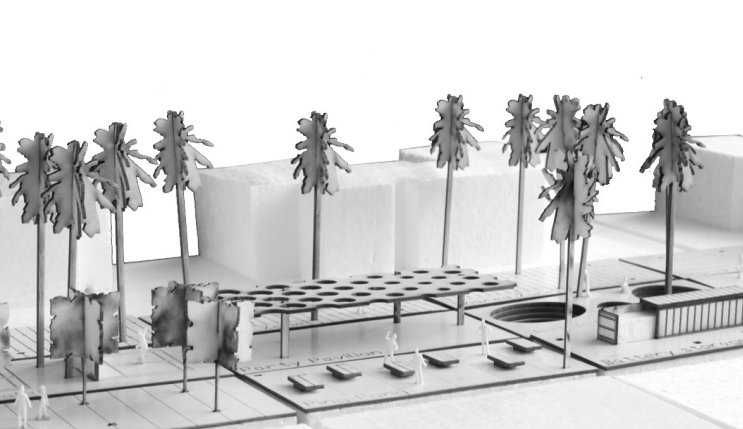

We examined how much planned design is needed. Why shouldn't we just support the energy and ambition of the people of a neighborhood? The urban layout would demonstrate "stills" of an urban process. At its core, this proposal is an offering to the Knutsford community to not oppose, but actually support urban consolidation
Knutsford street, Fremantle, Australia: client LandCorp WA (with Julian Bolleter / AUDRC) © Joerg Baumeister 2023

Flexible Housing: Serial, affordable technology



Housing+: From industrialisation to mass customisation; flexible in terms of positioning, height, facade, equipment, climate

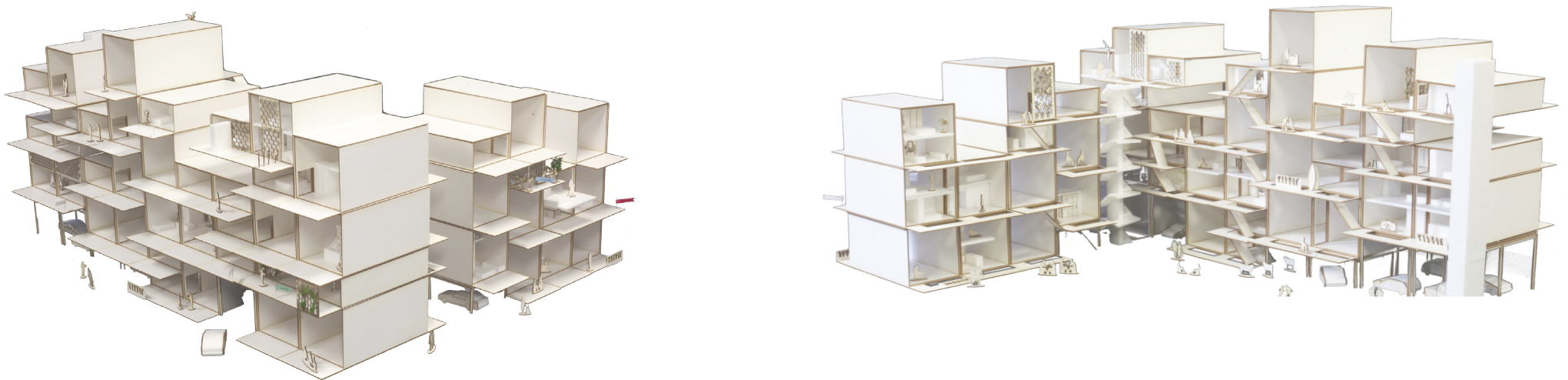

Ecological Network



A coordinated green infrastructure network can provide vital ecosystem services, alternative transport, and real estate market opportunities

Community-driven Ecological Systems

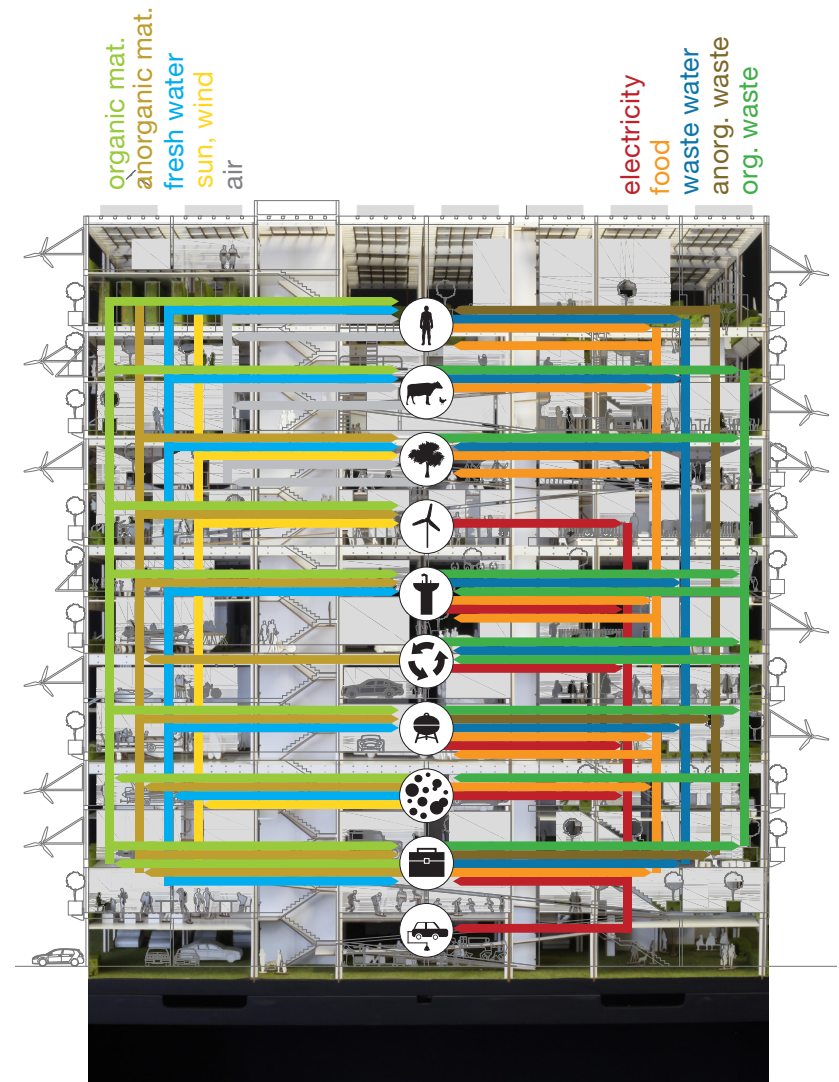

MiniCity:

A flexible, self-organising potential model for future cities providing both an own home with garden and urban density

Joerg Baumeister

Architectural and Urban Design Project Awards (230815)

Tallin Architecture Biennale 2022:

The SeaOasis proposal has been awarded by TAB 2022 Future Food Deal and exhibited from Sep - Nov 2022.

Aga Khan Award for Architecture Nominee 2012:

Guest House as demonstration building (with K. Ehlert, I. Becker), 2012, *German Embassy Addis Ababa*.

First Prize 2004:

"German Urban Design Award" (Deutscher Städtebau Preis 2004), Gemüsemarkt Fulda: Realization of a market square and three new buildings (with T. Scheel), 2001-2004, Fulda.

First Prize (out of 1000 applications) 2000:

Competition Central Market Square Fulda (with T. Scheel), 2000, City of Fulda.

Bauwelt-Award 1997:

SW 296 in Nova Scotia, Canada: Seafront cottage, 1996.

First Prize 1995:

Competition and realization of the Business Centre Marienplatz Schwerin (in AST), 1995, City of Schwerin.

Fourth Prize 1991:

Competition Masterplan University Kiel (with B. Kunst), 1991, City of Kiel.

Schinkel-Award First Prize 1990:

Competition Masterplan Areal Anhalter Bahnhof, Berlin, 1990, BDI/AIV.

Architecture Award Braunschweig:

Competition Business District Braunschweig, 1989, Beyrich.

Second Prize:

An der Urania, Berlin: Competition for an urban development, 1987, BDI/AIV.