

Roomy Musterprojekt

Created on
2020-07-26

Total area 69.60 m ²	Floors 1	Rooms 3	Bathroom 1
---	--------------------	-------------------	----------------------



Roomy Musterprojekt

TOTAL AREA: 69.60 m² • LIVING AREA: 75.16 m² • FLOORS: 1 • ROOMS: 3

▼ Ground Floor

TOTAL AREA: 69.60 m² • LIVING AREA: 75.16 m² • ROOMS: 10

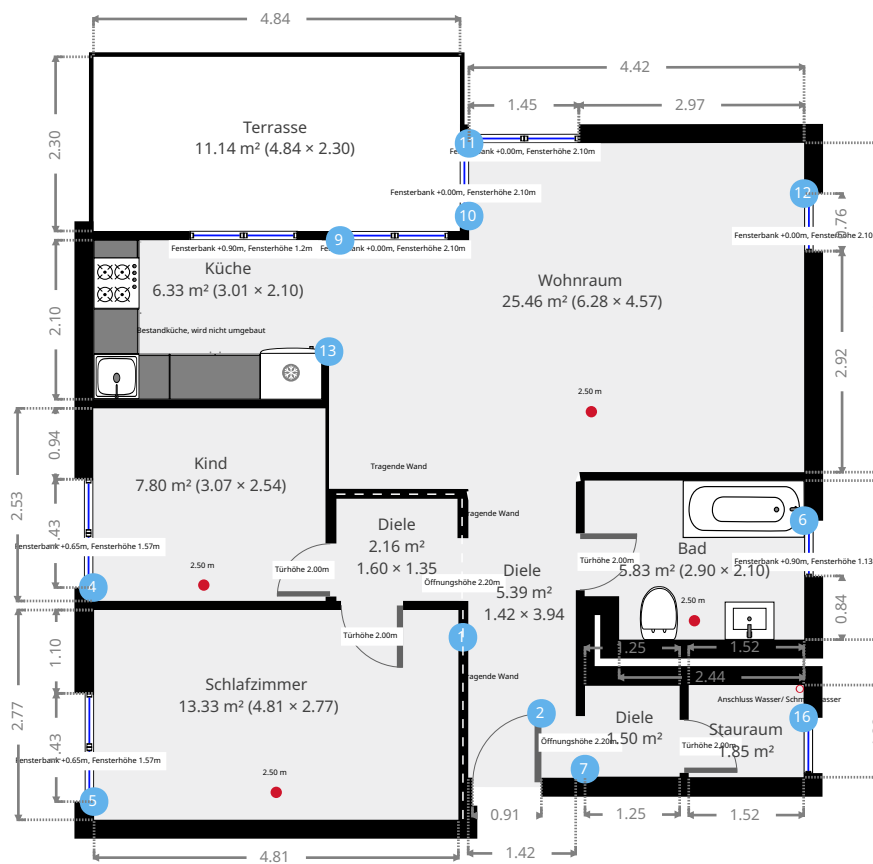

▼ Schlafzimmer Ground Floor

WIDTH: 4.81 m • LENGTH: 2.77 m • CEILING HEIGHT: 2.54 m
AREA: 13.33 m² • PERIMETER: 15.16 m

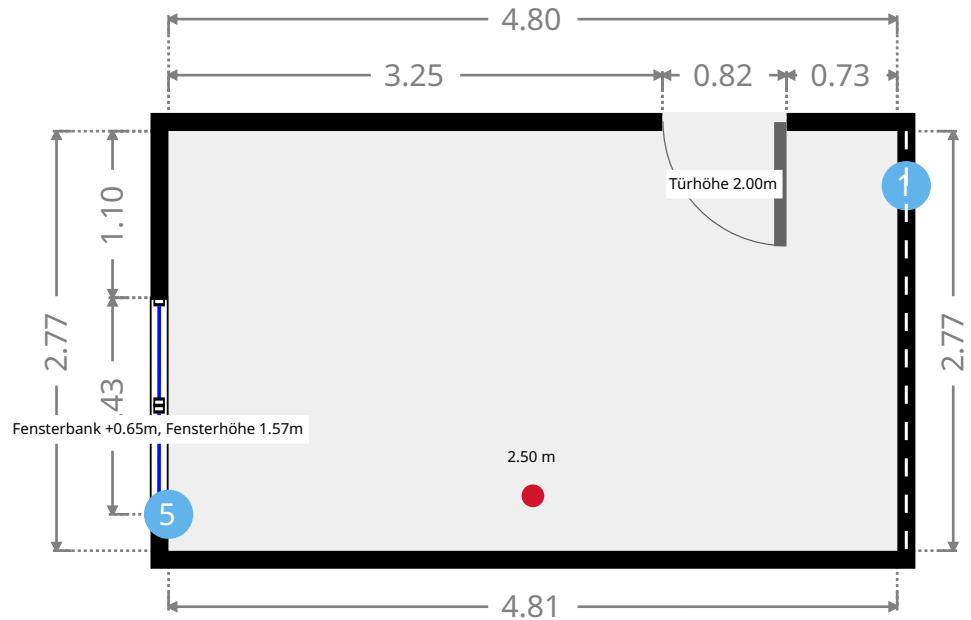
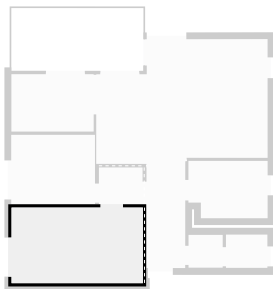

▼ Schlafzimmer /Ground Floor

1	WALL	
	Notes	
	Giftgas	
5	FENSTERBANK +0.65M, FENSTERHÖHE 1.57M	
	Height	
	1.56 m	
	Distance to Floor	
	0.66 m	

▼ Diele Ground Floor

WIDTH: 1.42 m • LENGTH: 3.94 m • CEILING HEIGHT: 2.35 m
AREA: 5.39 m² • PERIMETER: 10.46 m

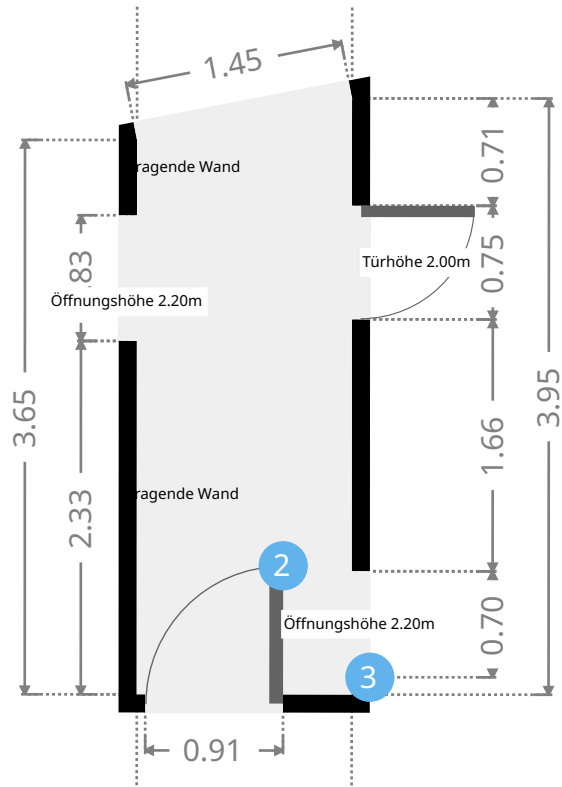

▼ Diele /Ground Floor

2 HINGED DOOR

Height
2.08 m



3 ÖFFNUNGSHÖHE 2.20M

Height
2.19 m



▼ Kind Ground Floor

WIDTH: 3.07 m • LENGTH: 2.54 m • CEILING HEIGHT: 2.50 m
AREA: 7.80 m² • PERIMETER: 11.22 m

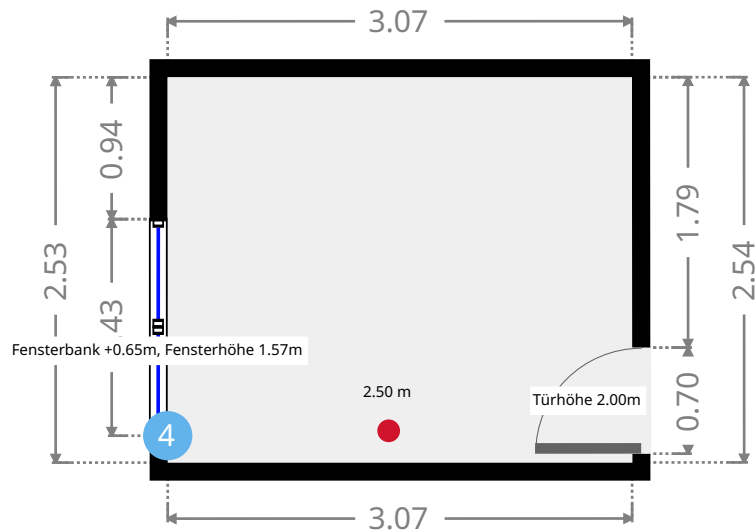
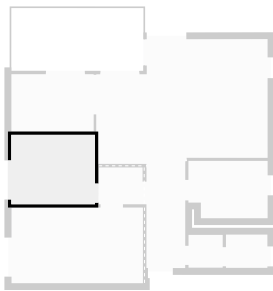

▼ Kind/Ground Floor

4 FENSTERBANK +0.65M, FENSTERHÖHE 1.57M

Height
1.57 m

Distance to Floor
0.66 m



▼ Bad Ground Floor

WIDTH: 2.90 m • LENGTH: 2.10 m • CEILING HEIGHT: 2.40 m
AREA: 5.83 m² • PERIMETER: 10.00 m

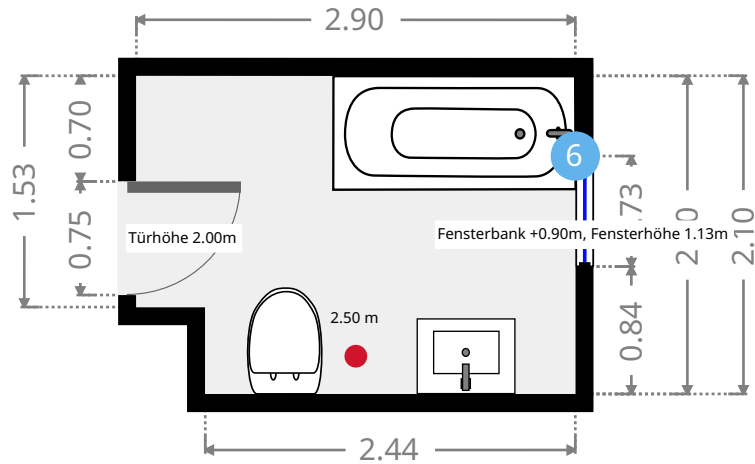
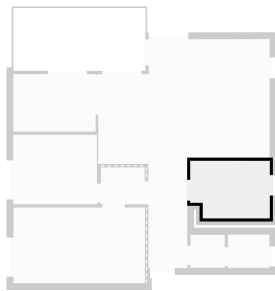

▼ Bad /Ground Floor

6 FENSTERBANK +0.90M, FENSTERHÖHE 1.13M

Height
1.13 m

Distance to Floor
0.90 m



▼ Diele Ground Floor

WIDTH: 1.25 m • LENGTH: 1.20 m • CEILING HEIGHT: 2.45 m
AREA: 1.50 m² • PERIMETER: 4.90 m

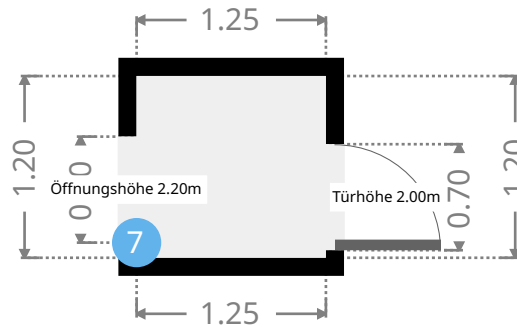
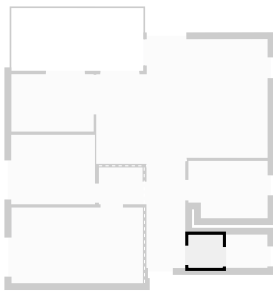

▼ Diele/Ground Floor

7 ÖFFNUNGSHÖHE 2.20M

Height
2.19 m



▼ Wohnraum Ground Floor

WIDTH: 6.28 m • LENGTH: 4.57 m • CEILING HEIGHT: 2.49 m
AREA: 25.46 m² • PERIMETER: 21.48 m

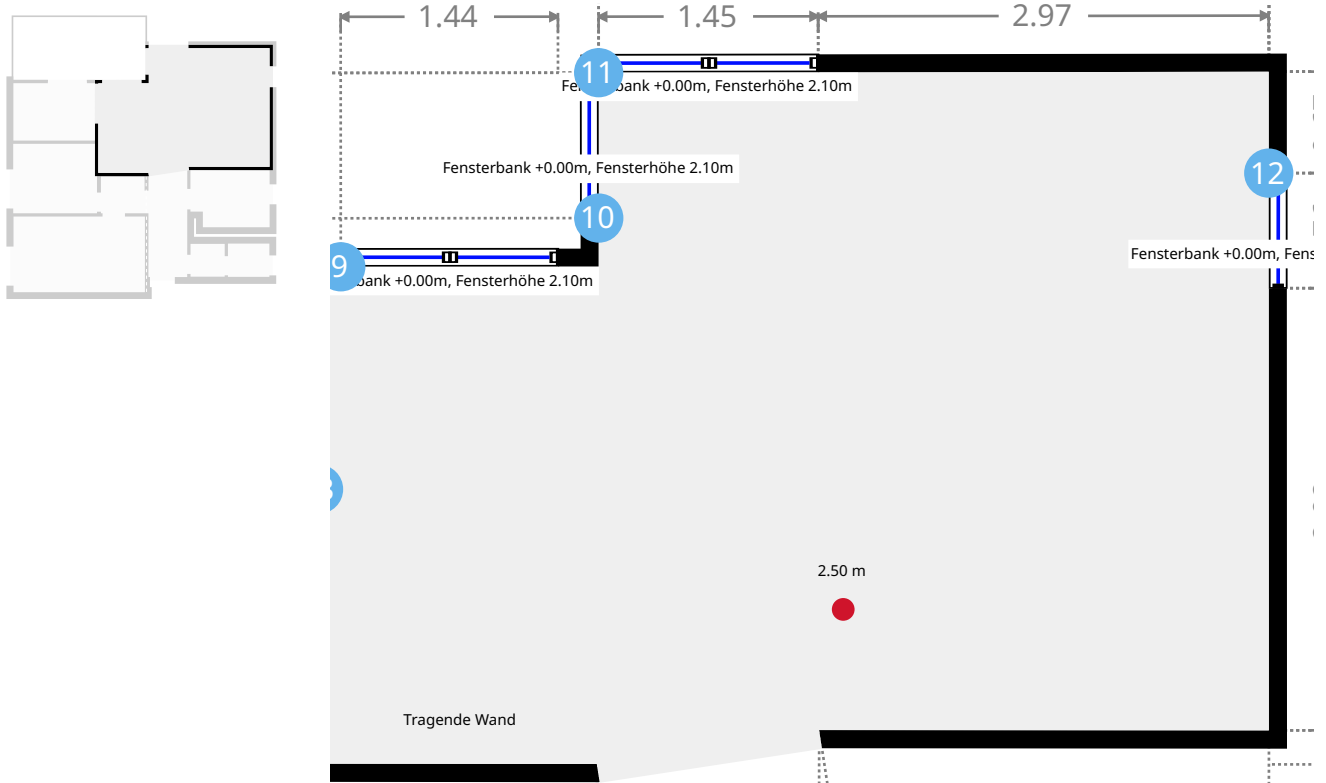

▼ Wohnraum /Ground Floor

Lichte Höhe
2.50m

9 FENSTERBANK +0.00M, FENSTERHÖHE 2.10M

Height
2.10 m

Distance to Floor
0.00 m



10 FENSTERBANK +0.00M, FENSTERHÖHE 2.10M

Height
2.10 m

Distance to Floor
0.00 m



11 FENSTERBANK +0.00M, FENSTERHÖHE 2.10M

Height
2.10 m

Distance to Floor
0.00 m



▼ Wohnraum /Ground Floor

12 FENSTERBANK +0.00M, FENSTERHÖHE 2.10M

Height
2.10 m

Distance to Floor
0.00 m



13 OPENING

Height
2.49 m



▼ Stauraum Ground Floor

WIDTH: 1.52 m • LENGTH: 1.22 m
AREA: 1.85 m² • PERIMETER: 5.47 m

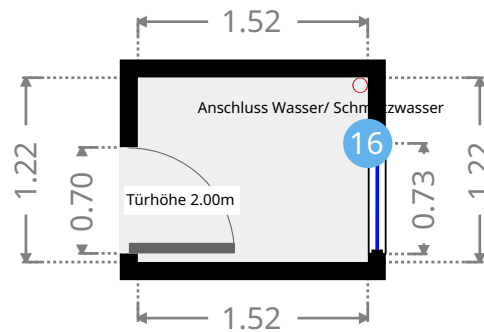
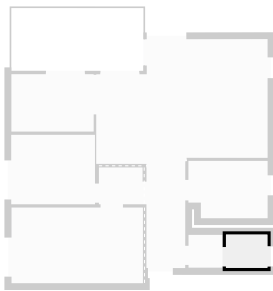

▼ Stauraum/Ground Floor

16 CASEMENT WINDOW

Height
1.13 m

Distance to Floor
0.90 m

