

# **BUS OPERATION INSTRUCTIONS (MANUAL)**



**GTK6859BEVB1 – 8.5m full electric city bus**

**eurabus**  
DRIVEN BY ELECTRIC POWER

Manufacturer: Eurabus GmbH  
Address: Rapsweg 23, D-12683 Berlin, Germany  
Tel.: +49-30-9210-907-60  
E-Mail: hello@eurabus.de  
Registered: HRB 168 446B, Amtsgericht Charlottenburg / Berlin  
Represented by: CEO/Geschäftsführer Thomas-Christian Seitz

# 1 Introduction

Dear EURABUS Driver,

These operating instructions provide the driver and accompanying personnel with information on safe and correct handling, maintenance, and servicing of the vehicle, in a clear and concise form. It is therefore important that you take some time to fully familiarize yourself with the vehicle.

These operating instructions cover several vehicle models as listed under "Technical data". It also refers to important optional equipment, so the design of your vehicle may deviate from some of the descriptions and illustrations.

EURABUS vehicles are equipped with a wide range of assemblies and accessories according to customer requirements, e.g.:

- Engines
- Axles
- Steering systems
- Heating systems
- Air conditioning systems

The respective manufacturers' operating instructions are included with the vehicle. Please observe the relevant operating and maintenance information contained within.

Servicing and maintenance work performed in good time and in the correct manner at the specified maintenance intervals will assure the operating safety, road safety and operating reliability of the bus.

All persons charged with operating and maintaining the vehicle must have read and understood these operating instructions and the operating instructions from the various manufacturers before driving the vehicle or commencing any maintenance or servicing work.

This applies to the information in the sections "Safety and the environment", "Safety equipment", "Technical data" and the safety notes provided in these operating instructions.

Non-observance of these operating instructions and the enclosed manufacturers' operating instructions will render any warranty entitlement void.

Only use genuine EURABUS replacement parts and accessories or those approved by EURABUS. Only genuine replacement parts that we have approved have been specially tested by us to ensure their reliability, safety, and suitability for use on the vehicle.

The use of non-approved parts will render any warranty or warranty entitlement void. Even after the period of warranty cover has expired, we recommend the use of genuine replacement parts to ensure continued operating efficiency of the vehicle.

These operating instructions are part of the vehicle. They must be kept in a safe place and be always accessible to the operating personnel of the vehicle.

Eurabus GmbH has a declared interest in promoting environmental protection. This starts right from the design and development stage of our vehicles. In this way we ensure that no environmentally hazardous materials are used, and, for example, emission values meet the highest requirements.

An economical driving style will contribute to preserving the earth's resources and the environment. Please always observe the regulations, instructions and tips provided in these operating instructions and the manufacturers' operating instructions.

We hope you enjoy the vehicle and always have a safe journey.

*Eurabus GmbH*

## 2 Table of Contents

1	Introduction.....	3
3	Sections, Typographical conventions.....	10
3.1	Sections .....	10
3.2	Typographical conventions .....	11
4	Safety, Health, Environment.....	12
4.1	Safe operation .....	12
4.1.1	General safety instructions.....	12
4.1.2	Qualifications of driving and maintenance personnel.....	12
4.1.3	Intended use, reason for use.....	12
4.1.4	Transporting mobility impaired passengers .....	13
4.1.5	Maintaining operating safety.....	13
4.1.6	Avoiding accidents with personal injury - Safety regulations.....	14
4.1.7	Driving and rest periods .....	15
4.1.8	Use of two-way radio equipment and cell phones.....	15
4.1.9	Handling 24V batteries – Safety instructions.....	16
4.1.10	Handling air conditioning systems - Safety instructions.....	17
4.1.11	Safety measures for protection of electrical control units .....	17
4.1.12	Safety measures for protection against electrical discharge .....	18
4.2	Healthy and relaxed driving.....	19
4.2.1	Sitting correctly.....	19
4.2.2	Breaks .....	19
4.2.3	Nutrition .....	20
4.3	Reference to environmental protection .....	21
4.3.1	Disposal of service fluids .....	21
4.3.2	Driving economically .....	22
5	Operation.....	23
5.1	Locking / unlocking vehicle.....	23
5.1.1	Opening / closing doors from outside .....	23
5.1.2	Opening / closing doors from inside .....	23
5.1.3	Opening / closing engine compartment flap.....	25
5.1.4	Opening / closing service flaps.....	26
5.2	Adjusting cockpit .....	27
5.2.1	Adjusting driver's seat .....	27
5.2.2	Adjusting steering wheel .....	27
5.2.3	Adjusting exterior mirrors .....	28

5.2.4	Opening / closing driver's sliding window .....	29
5.2.5	Windscreen roller blind .....	29
5.3	Heating, Ventilation, Air Conditioning (HVAC).....	30
5.3.1	Control panels in passenger compartment and cockpit.....	30
5.3.2	Displays .....	31
5.3.3	Defrosting .....	31
5.3.4	Air recirculation mode .....	31
5.4	Audio / video .....	32
5.4.1	Using microphone .....	32
5.4.2	Radio.....	32
5.4.3	Monitors .....	33
6	Safety Equipment .....	34
6.1	General .....	34
6.1.1	Checking and servicing .....	34
6.2	Seat belts .....	35
6.2.1	Fastening seat belt.....	35
6.3	Emergency Equipment .....	36
6.3.1	Warning triangle, flashing warning light, warning equipment.....	36
6.3.2	Wheel chocks.....	36
6.3.3	Emergency hammers .....	37
6.3.4	First aid box .....	37
6.3.5	Fire extinguisher .....	38
6.4	Exiting vehicle in an emergency .....	39
6.4.1	Opening doors from outside using emergency handle .....	39
6.4.2	Opening doors from inside using emergency lever .....	39
6.4.3	Emergency exits.....	40
6.4.4	Switching off HV system in an emergency.....	41
6.4.5	Releasing parking brake in an emergency .....	42
6.4.6	Reversing system .....	42
6.4.7	Undervoltage protection feature.....	43
6.4.8	Drive-off lock while doors are open .....	43
7	Cockpit.....	44
7.1	Buttons, left .....	44
7.1.1	Description of left button cluster .....	44
7.2	Hazard warning lights .....	47
7.2.1	Hazard warning lights .....	47
7.3	Parking lights and headlights.....	48
7.3.1	Activating side lights and driving lights .....	48

7.4	Instrument Cluster .....	49
7.4.1	Speedometer .....	49
7.4.2	Coolant and component temperatures .....	49
7.4.3	SoC .....	49
7.4.4	Brake pressure .....	50
7.4.5	Check lamps .....	50
7.4.6	Menu .....	51
7.4.7	Priority 1 malfunctions and messages .....	51
7.4.8	Priority 2 malfunctions and messages .....	52
7.4.9	Priority 3 information and notes .....	53
7.4.10	Function messages .....	53
8	Driving .....	54
8.1	Driving economically .....	54
8.1.1	Running-in instructions .....	54
8.2	Before starting journey .....	55
8.2.1	Preparations before each journey .....	55
8.2.2	Starting the high voltage (HV) system .....	56
8.2.3	Driving direction selection .....	59
8.3	Driving systems .....	60
8.3.1	Electronically controlled braking system (EBS) .....	60
8.4	Multi-function lever .....	63
8.4.1	Operating multi-function lever .....	63
8.5	Braking .....	65
8.5.1	Service brakes .....	65
8.5.2	Frequent-stop brake (FSB/Auto hold) .....	65
8.5.3	Retarder/virtual retarder .....	67
8.6	Parking .....	70
8.6.1	Engaging parking brake, parking vehicle .....	70
8.7	Charging .....	72
8.7.1	Charging .....	72
8.7.2	emergency release of charging gun .....	72
9	Practical advice .....	73
9.1	Towing .....	73
9.1.1	Safety precautions on towing .....	73
9.1.2	Front towing .....	74
9.1.3	Towing buses with defective engine or transmission .....	75
9.1.4	Towing buses with axle and steering damage .....	75
9.1.5	Removing prop shaft .....	76

9.1.6	Recovering buses from rough terrain .....	77
9.2	Loss of air pressure .....	78
9.2.1	Releasing spring actuators mechanically .....	78
9.2.2	Charging vehicle with air from external source .....	79
9.2.3	Manoeuvrability of vehicle if air suspension is depressurized .....	80
9.3	Changing wheel .....	81
9.3.1	Changing wheel .....	81
9.4	Slave starting / assisted starting the 24V system .....	84
9.4.1	Safety precautions for slave starting and assisted starting .....	84
9.4.2	Slave starting .....	84
9.4.3	Assisted starting .....	85
9.5	Mechanical battery isolating switch .....	86
9.5.1	Isolating electrical system from battery .....	86
9.6	Overview of lamps .....	87
9.6.1	Overview of vehicle exterior lights .....	87
9.7	Changing fuses .....	88
9.7.1	Changing fuses or relays .....	88
9.7.2	Fuses and relays in switch panel at rear of vehicle .....	89
9.8	Troubleshooting .....	90
9.8.1	Troubleshooting .....	90
10	Maintenance & Care .....	93
10.1	Information about environmental protection .....	93
10.1.1	Information about environmental protection .....	93
10.1.2	Service work to be undertaken .....	94
10.1.3	Checking and replenishing coolant .....	95
10.1.4	Checking steering hydraulic fluid level .....	96
10.1.5	Replenishing fluid in windscreen washer system .....	97
10.1.6	Changing wiper blades .....	98
10.1.7	Checking condition of air suspension bellows .....	99
10.1.8	Checking compressed air tanks for water accumulation .....	100
10.1.9	Checking brake pad/lining wear .....	101
10.2	Decommissioning / recommissioning .....	103
10.2.1	Demobilising vehicle .....	103
10.2.2	Re-commissioning vehicle .....	104
10.3	Cleaning and care .....	105
10.3.1	Cleaning and care of vehicle .....	105
11	TECHNICAL DATA .....	115
11.1	Data plates .....	115



11.1.1	Vehicle and component type plates .....	115
11.2	Dimensions, weights, loads .....	116
11.2.1	Vehicle dimensions .....	116
11.2.2	Turning circles .....	116
11.3	Engine .....	117
11.3.1	Basic traction motor data .....	117
11.4	Wheels and tyres .....	117
11.4.1	Torque settings for wheel nuts .....	117
11.4.2	Tyres and rim sizes .....	117
11.4.3	Speed index .....	118
11.4.4	Tyre pressures .....	118
11.5	Capacities and service fluids .....	119
11.5.1	Coolant mixing ratios .....	119
11.5.2	Windscreen washer reservoir .....	119
11.6	Speeds .....	120
11.6.1	Speed limitation .....	120
11.7	Number of seats and doors .....	120
11.7.1	Seats .....	120
11.7.2	Number of doors .....	120
11.8	Other .....	120
11.8.1	Electrical system .....	120
11.8.2	Climatic environmental conditions .....	120
12	INDICES .....	121
12.1	Abbreviations .....	121
12.2	Glossary .....	123

## 3 Sections, Typographical conventions

### 3.1 Sections

These operating instructions are intended to assist you in all situations with the vehicle. The operating instructions are sub-divided into the following sections.

#### **Safety, Health, Environment**

Here, you can find information about the safe operation of your vehicle and notes about health and safety and environmental protection.

#### **Operation**

Here, you can find detailed information about the equipment installed in your vehicle. This section supplements the main sections describing the cockpit and driving. Therefore, read this section carefully before driving the vehicle for the first time and familiarize yourself thoroughly with the equipment on your vehicle.

#### **Safety equipment**

Here, you can find a description of all items of safety equipment in your vehicle and how the equipment works. It is essential that you familiarise yourself with the safety equipment so that the vehicle can be operated in the correct manner.

#### **Cockpit**

In this main section you can find information about the switches, instruments, displays and check lamps of the instrument panel.

#### **Driving**

Here, you can find the information you need to drive the vehicle. Read this section before starting the engine for the first time.

#### **Practical advice**

This main section provides you with instructions on how to proceed in the event of breakdown and describes possible ways to solve problems.

#### **Maintenance and care**

This section provides information on maintenance and care of the vehicle.

#### **Technical data**

All the important technical data relating to the vehicle can be found here.

#### **Abbreviations and index**

A list of contents and glossary of terms help to find the desired information quickly.

The list of abbreviations explains the abbreviations used in these operating instructions.

The glossary of terms explains the most important technical terms relating to your vehicle.

## 3.2 Typographical conventions

The following typographical conventions are used in these operating instructions:



### Warning

A warning refers to possible risks to the health or life of yourself or others that may be encountered when handling or operating this vehicle.



This notice draws your attention to possible hazards to your vehicle.



This information provides you with additional advice and tips.



### Environmental note

A warning refers to possible risks to the health or life of yourself or others that may be encountered when handling or operating this vehicle.



The book symbol refers you to detailed information on the subject in the manufacturers' operating instructions.

- ▶ This symbol means that an action is required.
- ▶ Several of these symbols in a row indicate a series of actions.

### **[chapter, page]**

This symbol indicates the chapter and page on which you will find more details on the subject.

Designations such as left or right always relate to the direction of travel unless the content of the text or illustrations indicate otherwise. On right-hand drive models, descriptions of the cockpit layout must always be interpreted as a mirror image of left-hand drive models.

## 4 Safety, Health, Environment

### 4.1 Safe operation

#### 4.1.1 General safety instructions

Before bringing it into operation and before working on the vehicle, read these operating instructions and the operating instructions from the device and assembly manufacturers (supplied) carefully and always observe the safety instructions.

Safety instructions guard against risks to life and limb. They avoid personal, material, and environmental damage resulting from improper use of the vehicle.

The vehicle owner is responsible for any injury or damage due to non-observance of these operating instructions.

The operator/owner must ensure that the personnel entrusted with driving and maintaining the vehicle have read and understood these operating instructions. Should there be any doubt or uncertainty after reading these operating instructions, please contact Eurabus GmbH without delay.

#### 4.1.2 Qualifications of driving and maintenance personnel

Persons who are charged with driving the vehicle or working on the vehicle must:

- Have reached the minimum legal age.
- Have been authorized to do so by the operator/owner.
- Be physically and mentally fit.
- Have the appropriate training and qualifications.

The vehicle owner will bear responsibility for this. All prevailing national regulations must be observed.



---

Testing, adjusting and repair work should only be carried out by EURABUS or EURABUS-approved specialist personnel.

Maintenance work described in the maintenance record and the maintenance check lists should only be carried out by EURABUS-approved specialist personnel.

#### 4.1.3 Intended use, reason for use

The vehicle is exclusively designed for the transportation of passengers and their luggage. The maximum number of passenger seats must not be exceeded.



---

The maximum number of passenger seats is specified in the vehicle registration documents.

Any other use beyond that which has been stipulated is deemed to be not intended. The vehicle owner will be held liable for any resulting damage.

The vehicle must not be used for any type of goods or freight transportation (except for customers' travel bags, suitcases, etc.).



---

When operating the vehicle, it is essential that the following information, legislation, and guidelines are observed:

- The safety instructions included in these operating instructions and the manufacturer's operating instructions.
- The chapter entitled "Technical data" in these operating instructions and the manufacturer's operating instructions.
- Road traffic regulations (highway code)
- Vehicle licensing regulations
- Other country-specific regulations.

#### **4.1.4 Transporting mobility impaired passengers**

It is possible to transport mobility impaired persons using the vehicle, even if no special equipment is fitted. The degree of impairment, however, must permit the seat belt to be fastened properly to ensure secure restraint of the person in the passenger seat.

Wheelchairs, walking aids and similar must be stowed in the luggage compartment or secured inside the vehicle.

#### **4.1.5 Maintaining operating safety**

- The vehicle should only be used when it is in technically perfect condition and only for its intended use, while complying with all relevant safety and environmental aspects.
- Have all malfunctions which may affect vehicle safety rectified immediately at a EURABUS-approved service centre.
- Observe all safety instructions and warnings displayed on the vehicle.
- The vehicle owner must ensure the presence and legibility of all warnings and information signs throughout the vehicle's service life. Clean warning signs and notices on a regular basis.
- Any changes or modifications to the vehicle (tuning) made without the manufacturer's prior approval may lead to loss of the operating permit. Information about this is available from a EURABUS-approved service centre.
- All replacement parts and accessories must be either genuine EURABUS parts or parts which have been tested and approved by EURABUS. The reliability, safety and suitability of these parts have been specifically tested to ensure suitability for use on EURABUS vehicles.



The use of parts not approved by EURABUS could lead to damage on the vehicle. If parts are used that have not been approved by EURABUS, any warranty claims made against Eurabus GmbH will be rendered void.

- Perform all maintenance work completely and within the specified intervals as described in these operating instructions and in the maintenance record, or have such work carried out at a Eurabus-approved service centre.
- Perform all maintenance work completely and within the specified intervals as described in the maintenance check lists or have such work carried out at a Eurabus-approved service centre.

#### 4.1.6 Avoiding accidents with personal injury - Safety regulations

##### Commissioning, starting and operating

Before starting the engine, carefully read these operating instructions and the operating instructions from the engine manufacturer and familiarise yourself with the points dealing with safety issues. Have staff instructed by a EURABUS specialist if anything is unclear.



##### Risk of accident and injury

The engine should only be started and operated by authorized personnel. Make sure that the engine cannot be started by unauthorized persons.

- Only start the engine when the batteries are properly connected.
- Exhaust gases are toxic. Make sure that there is sufficient ventilation or use an extraction system if the engine is operated in enclosed spaces.
- Keep a safe distance from any rotating parts when the engine is running. Wear close-fitting work clothes. Limbs could be severed.
- Avoid contact with coolant. It is toxic and can cause irritation to the skin.
- Smouldering or burning wiring or cable insulation generates toxic smoke and harmful gases.



##### Risk of burns

- Never touch hot engine parts with bare hands - risk of burning.
- When the engine is at operating temperature, keep away from the exhaust system. This becomes hot during vehicle operation thereby presenting a risk of burns.
- Hot coolant can be discharged if there are leaks in the cooling circuit. Keep a safe distance and switch off the engine, if necessary, otherwise there is a risk of scalding.



Also observe the information contained in the operating instructions from the respective manufacturer.

---

#### 4.1.7 Driving and rest periods

Observance of driving and rest periods serves to protect the passengers, the driver and other road users.



#### Risk of accident

The driver's concentration can be affected by fatigue and overworking. The driver's reaction time is longer in sudden extreme situations (wild animals on road, icy road, traffic congestion, etc.).

This can lead to severe accidents. Therefore, the legally prescribed driving periods and rest periods must be always adhered to.



---

Depending on the vehicle model, the daily rest period can be taken in the rest cabin of the vehicle if the cabin complies with the applicable provisions for rest cabins in motor vehicles.



---

See also the legislative requirements and the country-specific regulations.

#### 4.1.8 Use of two-way radio equipment and cell phones



---

Operating mobile phones and two-way radios, even in standby mode, can lead to malfunctions in the vehicle electronics systems if their aerials are located inside the vehicle. This may jeopardize the operational safety of the vehicle.

Cell phones and two-way radios should therefore only be operated inside the vehicle if they are connected to an external aerial.



---

Since EURABUS is not able to appraise every product on the market, we recommend that advice is sought from a EURABUS service centre before purchasing an external aerial system.

#### 4.1.9 Handling 24V batteries – Safety instructions



#### Risk of injury

Fire, sparks, naked flames, and smoking are strictly prohibited when handling batteries.

Take extra care after prolonged driving or when charging batteries using a battery charger.

The batteries produce highly explosive oxy-hydrogen gas - ensure good ventilation.

Avoid producing sparks when connecting / disconnecting electrical consumers or measuring instruments directly to/from battery terminals.

Batteries contain corrosive acid. Always wear appropriate protective clothing, protective goggles, and acid-proof rubber gloves.

Never tip batteries. Electrolyte could flow out of the vent openings.

Always wear eye protection when performing work involving batteries.

Keep children away from batteries and battery acid.

Switch off all electrical consumers before connecting or disconnecting batteries.

Always disconnect the earth connection (-) first.

Avoid short-circuits caused by polarity reversal and by bridging terminals with tools or metal objects.

Only remove the terminal covers when necessary.

Always connect the earth connection (-) last when connecting the batteries.



Switch off battery isolating switch  **9.4.4., page 86**

Observe the following instructions to extend battery service life if the vehicle is immobilized for a period longer than 12 weeks:

- Disconnect the earth cable if the batteries are to remain in the vehicle.
- Check the fluid level in the battery. If the electrolyte level is too low, replenish with distilled water up to the maximum mark. This does not apply to batteries labelled "absolutely maintenance-free".



Observe the instructions from the battery manufacturer.



#### 4.1.10 Handling air conditioning systems - Safety instructions



##### Health hazard

Refrigerants and their vapours are hazardous to health.

- Avoid always contact. Always wear protective goggles and gloves. Consult a doctor immediately if refrigerant comes into contact with eyes or skin.
- Do not allow gaseous refrigerants to escape in enclosed rooms - risk of suffocation.



Always observe the following points when working on air conditioning systems:

- Have work on the refrigerant circuit carried out at a EURABUS-approved service centre.
- The air conditioning system is operated with R407C only.
- Never clean air conditioning systems using a steam jet cleaner.
- It is prohibited to use propane-butane refrigerants in EURABUS vehicles.



Strictly observe the operating instructions issued by the air conditioning system manufacturer.

#### 4.1.11 Safety measures for protection of electrical control units



##### Risk of fire

Repaired or incorrect control units can cause fires in the electrical system.

Do not repair control units. Check whether the correct control units have been installed at a EURABUS-approved service centre.



It is essential that the following safety precautions are observed to prevent damage to the control units.

- Only start the engine when the batteries are properly connected.
- Never disconnect the batteries while the engine is running.
- Do not use a rapid charger to start the engine. Only use a second battery to slave start.
- Remove the battery terminal clamps before rapid charging. Observe the operating instructions for the rapid charger.
- Disconnect the batteries and securely fix both cable clamps + and - to each other before performing any electrical welding.
- Only connect / disconnect control unit connectors when the electrical system is switched off.
- Avoid polarity reversal as this will result in irreparable damage to the control units.
- Control units must be removed if temperatures are expected to exceed 70 °C (e.g., in a drying oven).

- 
- Always tighten union nuts on electrical cable connections, e.g., on temperature and pressure sensors, to the specified tightening torque.

#### 4.1.12 Safety measures for protection against electrical discharge



**Risk of fire**

- Do not reach into areas where electrically charged components are located.
- Do not work with liquids on wires or components carrying an electric current or touch any of these.
- Make sure that protective clothing with sufficient electrical insulation is worn when working in areas where electrically charged components are located. Accidents due to electric shocks may cause severe injuries.



---

Also observe the instructions from the electrical system manufacturer.

## 4.2 Healthy and relaxed driving

### 4.2.1 Sitting correctly

Bus drivers sit up to nine hours a day at the steering wheel. In addition to concentrating on the traffic, there is also the physical effort of supporting and balancing the body.

Moreover, back, and joint problems can be caused by poor posture and poor backrest adjustment which can impair the driver's concentration.

To drive in a healthy and relaxed way, it is therefore important for the driver's seat and cockpit to be adjusted correctly and adapted to the driver's requirements and body size.



Adjusting driver's seat  5.2.1., page 27

### Staying fit



#### Risk of accident

Not paying attention to the traffic can lead to severe accidents. Only follow the advice provided if the traffic situation permits.

- ▶ Change the seating position slightly every 15 minutes.
- ▶ Stretch limbs at regular intervals.

### 4.2.2 Breaks



#### Risk of accident

The driver's concentration can be affected by fatigue and overworking. The driver's reaction time is longer in sudden extreme situations (wild animals on road, icy road, traffic congestion, etc.). This can lead to severe accidents.

Therefore, the legally prescribed driving periods and rest periods must be always adhered to. Additional breaks can also counteract the effects of fatigue and overworking.

Use breaks to stand up and move about so the body can get some exercise. This loosens up the muscles and reduces stress and tension and will also get your circulation working.

Do not stay seated while taking breaks.

#### Correct way to take breaks

- ▶ Perform exercises to loosen up your body and breathing.
- ▶ Perform aerobic exercises.
- ▶ Perform some light duties (like emptying the bins).



---

Additional advice can be obtained from the occupational health and safety office.

### 4.2.3 Nutrition

Fatigue and weariness when driving also come from the stomach. Heavy meals with lots of meat or fat and overeating egg-based dishes make you tired as the food is difficult to digest. Instead of this, eat meals that are rich in carbohydrates and vegetables.

#### Eating correctly and healthily

- ▶ Avoid large portions at lunch and evening mealtimes.
- ▶ Instead, eat snacks in between. This increases performance. Also, the low experienced at lunchtime is less prominent if there is no greasy food in your stomach.
- ▶ Avoid greasy and high calorie foods.
- ▶ Eat plenty of vitamin-rich foods (e.g., fresh fruit). Adopt this approach when driving as well.
- ▶ During the day, drink at least 1.5 to 2 litres of low energy and low-calorie fluids, such as mineral water, squash, or fruit tea.



---

There's no need to cut out coffee. But for every cup of coffee you drink, drink a glass of mineral water, squash, or fruit tea.

Additional advice can be obtained from the occupational health and safety office.

## 4.3 Reference to environmental protection

### 4.3.1 Disposal of service fluids



#### Environmental note

##### Coolant

Dispose of antifreeze and mixtures of antifreeze and water in the correct manner as hazardous waste. Observe local authority regulations and read the product and safety data sheets provided by the respective manufacturer.

##### Hydraulic fluid

Dispose of used hydraulic fluid in the correct manner as hazardous waste. Observe local authority regulations and read the product and safety data sheets provided by the respective manufacturer.

##### Filter and drying agent cartridges

Filter elements, such as oil and fuel filters, drying agent elements from air dryers are hazardous waste products and must be disposed of in the correct manner. Observe local authority regulations and read the product and safety data sheets provided by the respective manufacturer.

##### Batteries (24V batteries)

Old batteries contain hazardous materials. They must be returned to the seller to be disposed of correctly or taken to a collection point. Never dispose of used batteries as domestic waste. Please also observe the relevant national regulations.

##### Batteries (high voltage traction batteries)

The high voltage traction battery can be returned to Eurabus at the end of its operational life, to maintain the correct recycling process.

##### Refrigerant

Disposal of refrigerants (e.g., R 407C) should only be undertaken by specialist companies which have the trained personnel and technical equipment to do this. On no account may refrigerant be released into the atmosphere. Have a EURABUS service centre dispose of refrigerants. Please also observe the relevant national regulations.

##### Cleaning and care products

Only use cleaning and care products that comply with the legislation governing washing and cleaning products and that are registered with the office for environmental protection.

Cleaning and care products must be composed of biologically degradable substances (detergents).

Collect residual quantities of cleaning and care products in their original packaging and take to a collection point. Observe local authority regulations and read the product and safety data sheets provided by the respective manufacturer.



Information about collection points can be obtained from any EURABUS service centre, from the seller or supplier of the service fluids or from the local authorities.

Cleaning and care products  **10.3.1., page 105**

### 4.3.2 Driving economically

Electric energy consumption can be improved by driving with foresight, steady acceleration, timely braking and by observing several rules.

- Try to run the vehicle as smooth as possible, means avoiding heavy acceleration or braking.
- If a speed reduction is necessary, by traffic or by route schedule, try to roll without acceleration as long as possible. Second-efficient way to reduce the vehicle speed is to use the virtual retarder ( **8.5.3, page 67**), last one is using the brake pedal by foot.
- If the traffic situation permits, use the cruise control system (depending on type) as often as possible. The electronic cruise control system meters the fuel supply in a very economical way.



#### Environmental note

The malfunction indicator lamp (MIL) will light up if a malfunction of relevance for emissions occurs in the engine or exhaust system while the engine is running.

The engine could be emitting more pollutants than is legally permitted.

This would impose an unnecessary burden on the environment. Have the engine checked immediately at a EURABUS-approved service centre.

## 5 Operation

### 5.1 Locking / unlocking vehicle

#### 5.1.1 Opening / closing doors from outside

The front door can be opened and closed from outside using the button left to the front door.



#### Opening the doors

- ▶ If necessary, switch on battery isolating switch before opening the doors (☞ 9.4.4, page 86).
- ▶ Press the red button. The door will open.

#### Closing doors

- ▶ Press the green button. The door will close.

#### 5.1.2 Opening / closing doors from inside

The front door and the rear door can be opened and closed when the vehicle is stationary using the door buttons of the left button cluster in the instrument panel.



#### Risk of accident

Risk of injury from open doors as vehicle is being driven off. For safety reasons, the doors will not open when the vehicle is moving.

There could be persons in door 2 entrance area. When door 2 opens, these could fall out of the vehicle and sustain severe injuries.

Before opening door 2, switch on monitoring camera and observe screen.

Door 2 should only be opened once it is certain that there are no persons in the entrance area.

# i

If the door camera is switched on, the camera image of door 2 entrance area is shown on the driver monitor.

When door 2 opens, the camera switches on automatically. The camera image of door 2 entrance area is shown on the monitor and only disappears once door 2 is closed.

## Opening the doors

- ▶ Press button 1 for front door or button 2 for rear door. The respective door will open. The associated door is indicated in the driver info display.

## Closing doors

- ▶ Press button 1 for front door or button 2 for rear door. The respective door will close. The check symbol of the door button turns off.

## Opening / closing flaps

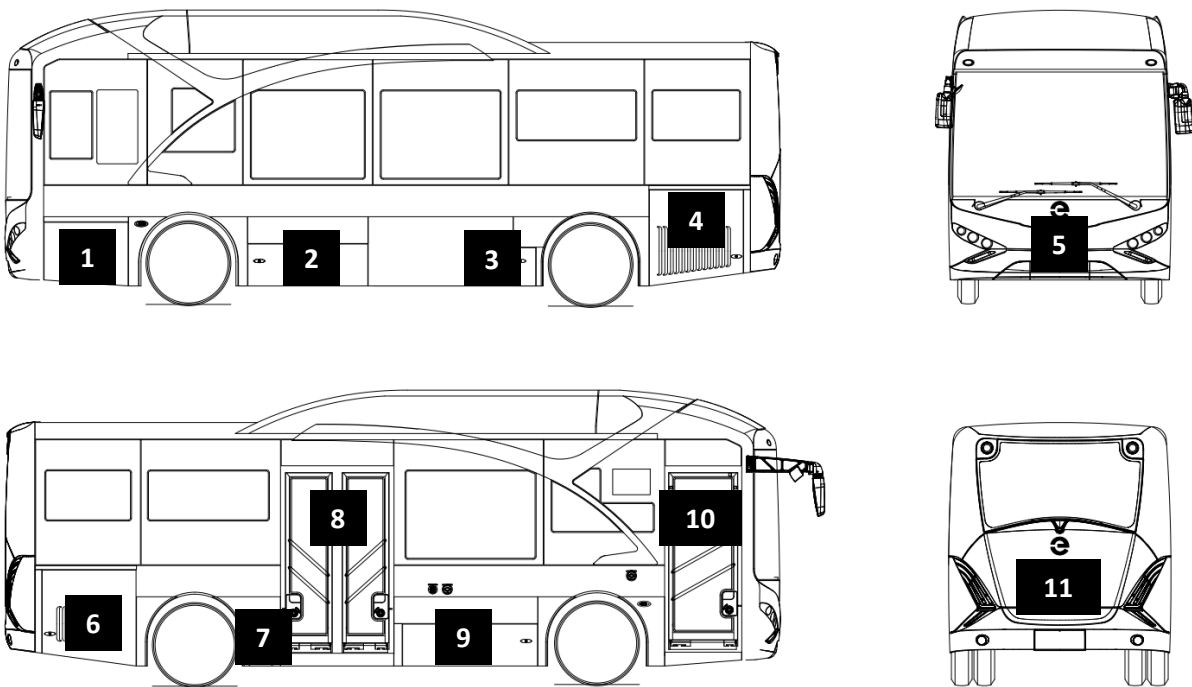

	Designation	Access to...
1	Service flap	Compressed air tank
2	Service flap	HV battery
3	Service flap	ECAS level sensor
4	Service flap	Cooling unit
5	Service flap	Windscreen wiper, washer water reservoir towing eye test connections for compressed air
6	Service flap	Cooling unit 24V battery
7	Service flap	ECAS level sensor



8	Passenger door 2	
9	Service flap	HV battery
10	Passenger door 1	
11	Service flap	Battery isolating switch electrics, fuse box

### 5.1.3 Opening / closing engine compartment flap

The engine compartment flap can be opened with this handle.



#### Risk of accident and injury

Leaving the engine compartment flap open could result in injury from moving parts or high voltage system components.

Limbs could be severed. Do not reach into areas with rotating or moving parts.  
Body parts could be electrocuted. Do not touch any orange component or component labelled with warning stickers.

Opening the engine compartment flap while the high voltage system is active does not cause the HV system to stop. Take particular care in this instance.

Driving the vehicle with the flaps open presents a serious risk to safety. It is therefore important to ensure that the engine compartment flap is closed and locked before starting a journey.

#### 5.1.4 Opening / closing service flaps



##### Risk of accident and injury

Driving the vehicle with the flaps open presents a serious risk to safety. It is therefore important to ensure that all service flaps are closed and locked before starting a journey.

Leaving the service flaps open could result in injury from moving parts or high voltage system components.

Limbs could be severed. Do not reach into areas with rotating or moving parts.

Body parts could be electrocuted. Do not touch any orange component or component labelled with warning stickers.

Opening the service flaps while the high voltage system is active does not cause the HV system to stop. Take particular care in this instance.

When opening / closing, make sure that no persons or objects are within the movement zone.

The service flaps are opened and closed using a square key.

##### Opening service flaps

- ▶ Release lock 1 using square key.
- ▶ Grab the service flap 2 at its lower edge and open.

##### Closing service flaps

- ▶ Push the service flap into the lock.
- ▶ Engage lock using square key.

## 5.2 Adjusting cockpit

### 5.2.1 Adjusting driver's seat



#### Risk of accident

Only adjust the driver's seat when the vehicle is stationary.

The seat locking mechanisms must engage audibly.

Otherwise, any unexpected movement in the seat could lead to control over the vehicle being lost.

Driver's seat (Grammar MSG90.6)

The driver's seat offers many adjustment options to suit the needs of the individual driver.



For further information and safety instructions, see also operating instructions of seat manufacturer.



Information about healthy and relaxed driving  **4.2., page 19.**



#### Risk of accident and injury

On no account should the seat be adjusted to a position that prevents the seat belt from being fastened correctly.

This would significantly impair safety.

### 5.2.2 Adjusting steering wheel



#### Risk of accident

Only adjust the steering wheel when the vehicle is stationary.

If this is done while the vehicle is in motion, control over the vehicle could be lost.

The angle of the steering wheel can be adjusted to suit the body. The image is for illustrative purposes only.

- ▶ Untighten the knobs left and right of the steering column.
- ▶ Move the steering wheel to the required position.
- ▶ Tighten the knobs left and right of the steering column.



steering wheel height  
adjustment knob

### 5.2.3 Adjusting exterior mirrors

Note: Depending on custom bus equipment, some of the mirrors may not be installed.

#### Adjusting exterior mirrors

The switch for adjusting the exterior mirrors is on the instrument panel console on the left-hand side of the cockpit.

- ▶ Take up the normal seating position on the driver's seat.
- ▶ Switch on ignition (↪ 8.2.2, page 56).
- ▶ Set rotary switch **1** to left exterior mirror or right exterior mirror.
- ↪ Press rotary switch in required direction until individual position of exterior mirror **2** is set.

#### Adjusting wide angle mirror

The wide-angle mirror **3** is mounted above the left and right exterior mirrors. It must be adjusted by hand.

- ▶ Take up the normal seating position on the driver's seat.
- ▶ Have a second person adjust the position of the mirror **3**.

#### Adjusting front-end monitoring mirror

The front-end monitoring mirror **4** is mounted above the right wide-angle mirror. It must be adjusted by hand.

- ▶ Take up the normal seating position on the driver's seat.
- ▶ Have a second person adjust the position of the mirror **4**.



---

The front-end monitoring mirror is only attached to the right exterior mirror.

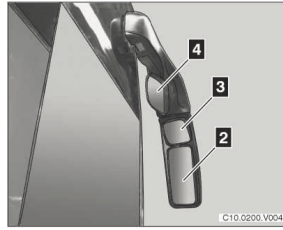

## 5.2.4 Opening / closing driver's sliding window

The driver's sliding window is located on the left next to the cockpit. Using the locking handle, the driver's sliding window is opened to the required position and closed.



### Risk of accident

Make sure that no parts of your body are between the windowpane and the frame when you close the driver's sliding window.



Depending on the weather conditions, close the driver's sliding window enough so that no moisture can enter the vehicle.

### Opening driver's sliding window

- ▶ Press down catch on locking handle and, at the same time, slide open driver's sliding window to the right in the direction of arrow.

### Closing driver's sliding window

- ▶ Press down catch on locking lever and, at the same time, slide driver's sliding window as far as it will go into the lock against the direction of arrow until it can be heard to engage securely.



Always close the driver's sliding window before leaving the vehicle.

## 5.2.5 Windscreen roller blind



### Risk of accident

When the vehicle is in motion, do not lower the roller blinds any more than necessary and do not restrict visibility to the mirrors.

Both roller blinds on the windscreen can be adjusted individually by hand.

## 5.3 Heating, Ventilation, Air Conditioning (HVAC)

### 5.3.1 Control panels in passenger compartment and cockpit



- 1** Temperature setting and AUTO mode
- 2** Display
- 3** Fan speed and ON/OFF
- 4** Defrosting windscreen
- 5** Manual flap setting
- 6** Air compressor ON/OFF
- 7** Heating ON/OFF
- 8** Additional PTC heating ON/OFF (option)
- 9** Fan only mode
- 10** Passenger compartment setting
- 11** Recirculated air



#### Risk of accident

Using the control panel while the vehicle is in motion will distract attention from the road and traffic. This can result in serious accidents.

Only operate the control panel if the traffic situation permits.

Always pay full attention to the road and traffic.

The operating unit for the heating, ventilation and air conditioning systems is ready for operation when the ignition is on. Cooling is only possible if the HV system is active (ignition key on or remote control via internet).

The air conditioning system must move large volumes of air both for heating and cooling. This means that temperature settings are only reached after a certain delay.

The less temperature settings are changed during operation, the more effectively the air conditioning system can function.

Always set the desired temperature before moving the vehicle.

### 5.3.2 Displays

The cockpit controls are displayed by default each time the ignition is switched on. The display is dark when the ignition is off.

The display is used to show information during fault diagnosis, calibration, or programming.

### 5.3.3 Defrosting

This function helps to demist the windscreen quickly.

#### Switching on defrost function

- ▶ Press button **4** – LED lights up in button.

The entire air flow from the front box is directed to the windscreen.

#### Switching off defrost function

- ▶ Press button **4** again – LED in button turns off.

The climate controller returns to normal mode.

### 5.3.4 Air recirculation mode

The entire vehicle interior can be switched over from fresh air mode to recirculating air mode (smog). The driver's area (cockpit) is set permanently to air recirculation mode in this case, whereby the passenger compartment has a time limit (max. 30 minutes).

#### Ventilating passenger compartment with recirculated air

- ▶ Press button **11**.

The LED in the button lights up in air recirculation mode.



---

The driver's window should also be closed when circulating-air mode is activated.

## 5.4 Audio / video

### 5.4.1 Using microphone



#### Risk of accident

Using the microphone and speaking into it while the vehicle is in motion can detract the driver's attention from the traffic and cause accidents.

Only operate the microphone if the traffic situation permits.

Always pay full attention to the road and traffic.

The microphone is located on the left wall of the driver cabin.

When the microphone is used, all other audio sources (radio, USB, ...) are switched off.

- ▶ Move microphone to desired position.
- ▶ Switch on microphone using switch at the microphone.
- ▶ Set volume using radio volume control.

### 5.4.2 Radio



When the microphone is switched on, the audio signals from the radio are suppressed (muted).



For further information regarding operation, see also manufacturer's operating instructions.



### 5.4.3 Monitors

#### Driver monitor

The driver monitor is showing the reversing camera image and the door 2 camera image. The camera image of door 2 always has priority.



## 6 Safety Equipment

### 6.1 General

#### 6.1.1 Checking and servicing



---

The safety devices and equipment must be checked on a daily basis to ensure they work and are complete.

Do not operate the vehicle if any safety equipment is defective or missing.

Never bridge, switch off or bypass any safety equipment.

The owner is responsible for ensuring that all the safety equipment is working properly.

Any tampering with or changes to safety equipment will render the operating permit void.

The safety equipment is designed in accordance with prevailing regulations and guidelines.

Please check the following points in particular - they explain the safety equipment for the driver and passengers:

- Check that the warning and information signs are present and legible.
- Check that the restraint systems are functioning properly and that they do not show any signs of wear (↪ **page 6.2.1, page 35**).
- Check that emergency equipment is complete and is stowed properly (↪ **6.3, page 36**).
- Check that the emergency levers and emergency exits are functioning correctly and are unobstructed (↪ **6.4.2 page 39 and ↪ 6.4.3, page 40**).
- Check reversing system works correctly (↪ **6.4.6, page 42**).
- Have fire alarms and fire extinguishing system checked at a Eurabus-approved service centre at regular intervals.

## 6.2 Seat belts

### 6.2.1 Fastening seat belt



#### Risk of accident and injury

Persons who do not have their seat belts fastened could sustain severe injuries. Fasten seat belts before every journey – Fasten seat belts before the vehicle drives off. Observe regulations if seat belts must be worn.

Do not secure objects together with a person using the same seat belt. Only use one seat belt per person. Fasten seat belts in the correct manner.

Modified belts no longer provide reliable protection from injury in the event of an accident. Any modifications that affect the efficiency of the belt are prohibited.

Sharp edges could damage the webbing strap. The webbing strap can no longer provide the required level of safety and could even tear. Do not run the belt straps over sharp edges.

**Check that seat belts are working correctly and have no signs of wear.**



#### Risk of accident and injury

Damaged seat belts or seat belts stretched in an accident are no longer capable of offering the required level of safety from injury.

Replace damaged seat belts or seat belts that have been stretched in an accident without delay.

Do not use seats if the corresponding seat belts are damaged.

If the seat belts exhibit any of the following damage, replace without delay:

- Signs of abrasion, crushing, fraying, tears.
- Inertia reel does not retract belt correctly. The belt is not sufficiently taut against the body as a result.
- Belt latch does not lock correctly.
- Inertia reel fittings or belt latch fittings are damaged.



#### Wearing seat belt correctly

- Do not twist the seat belt.
- Pull the three-point seat belt over the shoulder. Do not pass the belt over the neck or under the arm.
- Keep the belt tight against the body. Do not wear thick clothing. Thick clothing restricts the effectiveness of the restraint system.
- Avoid seating positions which prevent the seat belt from being worn correctly.
- During the journey, check from time to time that the seat belt is correctly fitted.

## 6.3 Emergency Equipment

### 6.3.1 Warning triangle, flashing warning light, warning equipment

A warning triangle, flashing warning light, high visibility vest and wind-proof flashlight can be found in the storage compartment on top of the driver cabin.

Familiarize yourself with the location of the emergency equipment before starting a journey.



A warning triangle, flashing warning light, high visibility vest and windproof flashlight must be kept on board the vehicle to comply with legal regulations. Observe national regulations.

Check the warning devices every day to make sure that they work correctly and are complete. Always stow away tools and accessories safely. Secure them to prevent them from moving around or rubbing against vehicle components such as electric cables.



Familiarize yourself with the location of the emergency equipment before starting a journey. Switch on the hazard warning lights in the event of an accident or breakdown.

Set up the hazard warning triangle or the flashing warning light where it can be clearly seen approx. 150 m behind the vehicle or in front of the danger zone.

### 6.3.2 Wheel chocks



#### Risk of accident and injury

Always secure the vehicle with wheel chocks if it is parked on gradients, when changing wheels or if there are faults in the braking system.

The vehicle could otherwise roll away.

Persons could fall, become trapped and sustain injuries caused by crushing.

- Position the wheel chocks in front of or behind the wheel, depending on the direction of the gradient.



Always check that the wheel chocks are complete and accessible.

Wheel chocks must be transported on board the vehicle and be ready to hand in accordance with legal requirements.

Observe national regulations.



### 6.3.3 Emergency hammers

Emergency hammers are attached to the ceiling on each side of the passenger compartment. There is also an emergency hammer above the cockpit.

The image is for illustrative purposes only.

- ▶ In an emergency, pull an emergency hammer from its holder.
- ▶ With short sharp blows, break one of the windows marked as an emergency exit (☞ **6.4.3, page 40**).
- ▶ Exit the vehicle through the smashed window.



#### Risk of fatal accident

Check the presence of all emergency hammers every day.

If emergency hammers are missing, it will not be possible to exit the vehicle quickly in an emergency.

Only use emergency hammers in an emergency.



Familiarize yourself with the location of the emergency hammers before starting a journey.



### 6.3.4 First aid box

The first aid boxes can be found in the overhead compartment of the driver cabin.

- ▶ Open flap using handle and remove.
- ▶ Place flap to one side.
- ▶ Take first aid box upwards out of the bracket.



Check every day that the first aid boxes are present.

Always make sure that the contents are complete.

Check the use-by date of the contents every year.

First aid boxes must comply with legal regulations.

Observe national regulations.

### 6.3.5 Fire extinguisher

The fire extinguishers can be found on the floor close to door 1.



#### Risk of accident

Defective or an insufficient number of fire extinguishers will be ill equipped to fight fire effectively. Fires will not be extinguished in good time. Legal regulations state that the vehicle must be equipped with at least one fire extinguisher with a fill capacity of 6 kg for fire classes A, B and C.

Observe national regulations. Have fire extinguishers checked for usability by qualified testers at least once a year.

Incorrect handling of fire extinguishers can lead to severe injuries and serious damage to the vehicle. Instruct driving and accompanying personnel on how to use the fire extinguisher so that they can act quickly in emergency situations. Besides the driving personnel, the registered keeper is also responsible for this.

#### Using fire extinguisher

- ▶ Pull off flap in forwards direction.
- ▶ Detach retaining strap and remove fire extinguisher from bracket.
- ▶ Make fire extinguisher ready for operation in accordance with instructions on fire extinguisher and fight fire.

## 6.4 Exiting vehicle in an emergency

### 6.4.1 Opening doors from outside using emergency handle

Emergency handles are actuated if the electrical system fails, or the vehicle has to be exited quickly in a critical situation.

The emergency handles can be found close to the door at the front and rear door.



#### Risk of accident

If an emergency handle is actuated, the door buttons in the instrument panel flash and a warning buzzer will sound.

Do not drive off - stop the vehicle immediately if already in motion. Determine cause and rectify fault.



Always unlock doors before starting a journey (👉 5.1, page 23). Only unlocked doors can be opened quickly in an emergency.

- ▶ Push the red button and open the glass.
- ▶ Rotate the red switch 90° clockwise.
- ▶ Open the door with your hand.



### 6.4.2 Opening doors from inside using emergency lever

Emergency levers are actuated if the electrical system fails, or the vehicle has to be exited quickly in a critical situation. The emergency levers are on the inside of the front and rear door.



#### Risk of accident

If an emergency lever is actuated, the door buttons in the instrument panel flash and a warning buzzer will sound.

Do not drive off - stop the vehicle immediately if already in motion. Determine cause and rectify fault.



Always unlock doors before starting a journey (☞ **5.1, page 23**). Only unlocked doors can be opened quickly in an emergency.

- ▶ Push the red button and open the glass.
- ▶ Rotate the red switch 90° clockwise.
- ▶ Open the door with your hand.



### 6.4.3 Emergency exits



#### Risk of accident

Do not post bills, hang textiles, decorations, or similar items in emergency exit areas.

Do not place objects in the emergency exit areas. Emergency exits must be freely accessible in an emergency, otherwise it will not be possible to take the necessary steps quickly if an emergency arises.

Before exiting the vehicle, ensure that the escape route does not pose a risk to life or limb (traffic, step, drop, etc.).

#### Rear and side windows

Emergency exit windows are identified by stickers.

- ▶ In an emergency, pull an emergency hammer from its holder (☞ **6.3.3, page 37**).
- ▶ With short, sharp blows, break a window marked as an emergency exit or rear window to exit the vehicle.





#### 6.4.4 Switching off HV system in an emergency

Pressing the emergency STOP switch causes the HV system to immediately shut down. The low voltage system (24V) will maintain active, to run sensors, logging, and water pumps.



#### Risk of accident and injury

The vehicle is not ready for operation if the engine, power assisted steering, ABS, transmission and so on have been shut down.

Only press the emergency STOP switch when the vehicle is stationary. The vehicle could otherwise roll away. People could trip, become trapped or limbs could be crushed.

Apply the parking brake.



Actuate the switch if the vehicle is to be completely and quickly shut down in an emergency.

#### Switching off the HV system

The emergency STOP switch is in 3 positions:

- on the instrument panel console on the left-hand side of the cockpit.
- inside the charging door.
- in the rear compartment of the bus.

Depending on the mechanical type:

- ▶ Push the mushroom shape button.
- ▶ Rotate the knob to the OFF position.



Only press the emergency STOP switch in an emergency and when the vehicle is stationary. Use the ignition to switch off the engine under normal operating conditions.

The rotary version can also be used as MSD for regular service, to ensure a locked system by the operating technician.



### 6.4.5 Releasing parking brake in an emergency

The emergency release device is joined to the parking brake valve. If a fault occurs in the compressed air system, the valve automatically switches to the reservoir for auxiliary air consumers and the spring actuators for the parking brake are released.

If there is a loss in pressure, the red STOP warning lamp lights up and the warning buzzer sounds. A symbol appears in the driver's display. The parking brake is on the instrument panel console on the left-hand side of the cockpit.

#### Releasing parking brake

- ▶ Pull the lever out of its engaged position and move it to the released position.

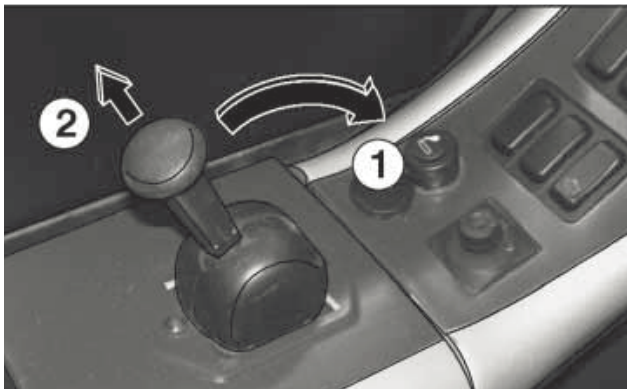

Only use the emergency release device to drive the vehicle out of a danger zone. Secure the vehicle from rolling away if it is standing on an uphill or downhill gradient before activating the emergency release device.



Release the parking brake mechanically if there is no pressure in the reservoir (↪ 6.4.5 page 42).

### 6.4.6 Reversing system

The door opens/closes automatically if persons or objects obstruct the door while it is opening/closing. Pressing the door button again will open/close the door.



#### Risk of injury

A defective reversing system cannot fulfil its function. This represents a serious risk of injury. Persons could become trapped!

Make sure that the reversing system is working properly before starting a journey.

Have the system checked at a Eurabus-approved service centre if it is not working properly.

### Checking operation of reversing system

- ▶ Switch on ignition.
- ▶ Actuate door button for front door 1 or relevant button in door handle.
- ▶ During the closing procedure, have a second person push against the front edge of the door.

The door must immediately stop its closing movement and return to the open position.

- ▶ Follow the same procedure for the rear door.



### 6.4.7 Undervoltage protection feature

The electric undervoltage protection feature is monitoring the 24V battery voltage, while the bus is parked, and the ignition key is turned off. When the 24V battery voltage drops below 22V, the system enables the HV system and the DC/DC converter and automatically recharges the low voltage battery.



#### Risk of injury

The HV system can start at any time during parking.

To ensure safe maintenance, disable the HV system and the 24V battery before you start working at the bus.

### 6.4.8 Drive-off lock while doors are open

The drive-off lock prevents people from getting injured if the bus pulls away with opened doors. It is integrated in the braking system together with the frequent stop brake.

#### How drive-off lock works

The drive-off lock is activated automatically in the following operating conditions:

- After doors have been opened.

When the accelerator pedal is depressed, the drive-off lock is released automatically in the following operating conditions:





- After doors have been closed.

## 7 Cockpit



### 7.1 Buttons, left

#### 7.1.1 Description of left button cluster



	Button	Function	Notes
		Ambient lighting ON/OFF ON = Press button down. OFF = Press button up.	
		Exterior mirror heating ON/OFF ON = Press button down. OFF = Press button up.	
		Fire extinguishing system Indicates, if one warning system detects smoke or fire. Open the lid and push button to extinguish	
		Force ATS ATS forced mode (override temperature logic) ON = Press button down. OFF = Press button up.	
		Kneeling Kneeling = Press button down. Press and hold down the button until it reaches the final kneeling position	

	Lowering vehicle	Lowering = Press button down. Press and hold down the button for at least 1 second: Lowers the vehicle	 <b>Risk of accident</b> Never drive for long distances with the vehicle raised or lowered. Only drive at walking pace with the vehicle raised or lowered.
	Vehicle riding level	Press and hold the button to level the vehicle back into riding level.	
	Road sign/destination board switch	Road signs ON/OFF ON = Press button down. OFF = Press button up.	
	Automatic low beam	Push the button to enable the light sensor, which operates the low beam	
	Automatic wiper system	Push the button to enable the rain sensor, which operates the wiper	
	Hazard warning lamp		
	Driver reading lamp	Driver reading lamp ON/OFF ON = Press button down. OFF = Press button up.	
	Passenger night light circuit 1	Passenger night light ON/OFF ON = Press button down. OFF = Press button up.	
	Passenger night light circuit 2	Passenger night light ON/OFF ON = Press button down. OFF = Press button up.	
	Rear fog lamp	Rear fog lamp ON/OFF ON = Press button down. OFF = Press button up.	

			<p>Front fog lamp</p>	<p>Front fog lamp ON/OFF  ON = Press button down.  OFF = Press button up.</p>	
			<p>Front door</p>	<p>Used to open and close the front door.  CLOSE = Press button.  OPEN = Press button again</p>	
			<p>Rear door</p>	<p>Used to open and close the rear door.  CLOSE = Press button.  OPEN = Press button again</p>	

## 7.2 Hazard warning lights

### 7.2.1 Hazard warning lights

The hazard warning lamp button can be found in the left button cluster in the instrument panel.

#### Switching on hazard warning lights

- ▶ Press button 1 once.

The following lamps flash in unison:

- Red check lamp in button
- Green turn signal indicators in multifunction display
- All turn signal lights on vehicle.

#### Switching off hazard warning lights

- ▶ Press button 1 again.



---

The hazard warning lights can also be activated with the ignition switched off.

Warning triangle, flashing warning light, warning equipment, vehicles tools and jack  **6.3, page 36.**

Switch on the hazard warning lights in the event of an accident or breakdown.

Set up the hazard warning triangle or the flashing warning light at a visible position approx. 150 m behind the vehicle or in front of the hazard area.

Switching off the battery isolating switch ( **9.4.4, page 86**) deactivates the hazard warning lights.

## 7.3 Parking lights and headlights

### 7.3.1 Activating side lights and driving lights

The parking lights and headlights are operated using the rotary switch on the left-hand side of the instrument panel.

#### Switching on parking lights

- ▶ Turn rotary switch to position.

The parking lights and side marker lights are switched on.

#### Switching off parking lights

- ▶ Turn back rotary switch to position.

#### Switching on driving lights

- ▶ Turn rotary switch to position.

#### Switching off driving lights

- ▶ Turn rotary switch back to position.

#### Switching on front fog lights

- ▶ Push the button in the left control panel.

#### Switching off front fog lights

- ▶ Push the button in the left control panel.

#### Switching on rear fog lights

- ▶ Push the button in the left control panel.

#### Switching off rear fog lights

- ▶ Push the button in the left control panel.



---

Only switch on the rear fog lights in fog when visibility is less than 50 m.



## 7.4 Instrument Cluster



### 7.4.1 Speedometer

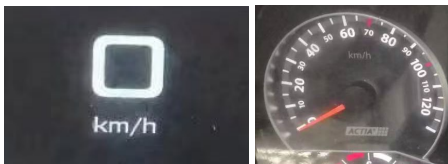

The kilometres or miles scale of the speedometer indicates the speed the vehicle is currently travelling at.

### 7.4.2 Coolant and component temperatures

Uint Max Voltage	3.316V	Power	6.1 kW
Uint Min Voltage	3.312V	Motor Temp	31°C
Uint Max Temp	28°C	Motor Controller temp	33°C
Uint Min Temp	23°C		

The coolant and component temperatures are shown after the ignition is switched on. The temperatures should not exceed 60°C during normal operation.

### 7.4.3 SoC

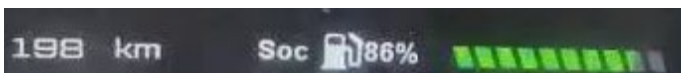

The state of charge (SoC) is indicating the remaining usable battery capacity and can be used from 100% to 0%. At low SoC, the display will show a warning and cabin cooling power may be reduced.

The display also indicates the remaining driving distance, based on the current driving style and heating/cooling requirements.

#### 7.4.4 Brake pressure



The brake pressure indicators provide details about the brake pressure currently being regulated in brake circuit 1 and brake circuit 2.

#### 7.4.5 Check lamps



#### Risk of accident

The central warning lamp indicates a priority 1 malfunction.

Operational and road safety is jeopardized.

Bring vehicle safely to halt immediately without causing a hazard to other traffic users.

Switch off the high voltage system.

Have the cause determined and rectified.

In conjunction with the analogue instruments, the check lamps and the displays in the vehicle menu inform the driver of the driving status.

The check lamps can light up or flash red, yellow, blue, and green. The number and position of the lamps varies depending on the equipment fitted in the vehicle.

## 7.4.6 Menu

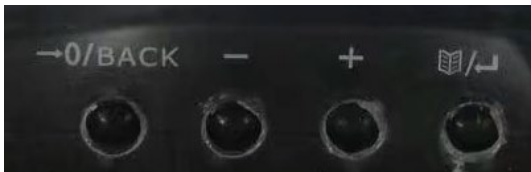

The content of the vehicle menu depends on the equipment fitted in the vehicle. Certain menu items may therefore not be available on your vehicle.

### Menu items

The menu contains the following menu items:

- Additional vehicle information, such as tire pressure, temperatures
- Diagnose information, fault codes, input/output states
- Settings menu, e.g., language



#### Risk of accident

Operating the vehicle menu while driving can distract the driver from the traffic situation. This can result in accidents caused by late braking or the vehicle veering off lane.

Therefore, only operate the vehicle menu when the vehicle is stationary.

## 7.4.7 Priority 1 malfunctions and messages

### Stop message: Safety

This message means that driving safety is jeopardized or there is a risk of damage to the vehicle.



#### Risk of accident

If a stop message appears, driving safety is jeopardized or the vehicle is not ready for operation.

Therefore:

- Bring the vehicle to a halt as soon as the traffic situation permits.
- If necessary, stop the engine, apply the parking brake, and secure the vehicle to prevent it from rolling away.
- Rectify the fault immediately; seek workshop assistance if necessary.

A STOP message is represented by:

- The STOP check lamp lighting up red and/or the central warning light lighting up yellow.
- A symbol and a message appearing in the display.
- An acoustic signal sounding.

A check lamp may additionally light up red. Meaning of stop message and remedies.



The vehicle is not ready for operation.

**Displayed when the vehicle is in motion:**

- Bring the vehicle to a halt as soon as the traffic situation permits.
- Expect reduced braking power.

**Displayed when the vehicle is stationary:**

- Allow the compressor to run until the cut-off pressure is reached (the message disappears).

**If the pressure is not reached:**

- Do not move the vehicle.
- Seek workshop assistance.

## 7.4.8 Priority 2 malfunctions and messages

Red message: Workshop

This message means that the vehicle must be taken to a workshop immediately. Driving safety may be impaired.



### Risk of accident

If a red message appears, driving safety may be impaired and the operating permit for the vehicle may be rendered void.

Therefore:

- Drive slowly and carefully.
- If necessary, stop the vehicle (in consideration of the traffic situation), switch off the HV system, apply the parking brake and secure the vehicle to prevent it from rolling away.
- Rectify the fault immediately.
- If necessary, seek advice from a Eurabus-approved service centre.

A red message is represented by:

- The warning triangle in the speedometer flashing red.
- The STOP check lamp lighting up red and/or the central warning light lighting up yellow.
- A symbol and a message appearing in the display.
- An acoustic signal sounding.

A check lamp may additionally light up red.

## 7.4.9 Priority 3 information and notes

### Yellow message: Information

Information together with recommended actions is displayed before or during a journey.



#### Risk of accident

If there is a fault in the anti-lock braking system (ABS), the braking behaviour of the vehicle will change.

For further information, see  **8.3.1, page 60.**

Increased tendency of the wheels to lock. This can cause the vehicle to skid.

Therefore:

- Drive slowly and carefully.
- Do not brake sharply.
- Seek assistance from a Eurabus service centre without delay.



If there is a fault in the exterior lighting, the operating permit for the vehicle could be rendered void. It may not be possible to continue the journey. Therefore, rectify any exterior lighting faults immediately.

A yellow message is represented by:

- The STOP check lamp lighting up red and/or the central warning light lighting up yellow.
- A symbol and a message appearing in the display.
- An acoustic signal sounding.

A check lamp may additionally light up red.

## 7.4.10 Function messages

### Function: Function message

A function or a recommended action is displayed.

A function message is represented by:

- A symbol and a message appearing in the display.  
and/or
- The STOP check lamp lighting up red.  
and/or
- The central warning lamp lights up yellow.  
and/or
- A check lamp lighting up red, yellow, green, or blue.

## 8 Driving

### 8.1 Driving economically

Electric energy consumption can be improved by driving with foresight, steady acceleration, timely braking and by observing several rules.

- Try to run the vehicle as smooth as possible, means avoiding heavy acceleration or braking.
- If a speed reduction is necessary, by traffic or by route schedule, try to roll without acceleration as long as possible. Second-efficient way to reduce the vehicle speed is to use the virtual retarder (↪ **8.5.3page 67**), last one is using the brake pedal by foot.
- If the traffic situation permits, use the cruise control system (depending on type) as often as possible. The electronic cruise control system meters the fuel supply in a very economical way.

#### 8.1.1 Running-in instructions

The electric traction system does not require any running-in procedure.

New tires require running-in before they reach their full grip. Do this by adopting a particularly careful style of driving for the first 100 kilometres.

After fitting new tires, drive with particular care since the protective coating of the tires does not allow optimum safety on wet roads, in bends and under braking.

Always retighten the wheel nuts on new vehicles after approx. 50 kilometres (↪ **9.3.1, page, 81**). Brake pads/linings do not brake at optimum frictional force when they are new. They must be run-in over the first 200 kilometres. Do this by adopting a particularly careful style of driving.

Avoid applying the brakes heavily or fully. Until they are run-in, new brake pads do not stop the vehicle as effectively!

## 8.2 Before starting journey

### 8.2.1 Preparations before each journey



---

The operational reliability of the vehicle is essential for safe driving. Therefore, carry out a check before every journey.

Check the following points every day before starting a journey:

#### Safety equipment ( ↻ 6, page 34)

- Are all the doors unlocked?
- Are the emergency levers working properly?
- Are the reversing systems on the doors working properly?
- Are all items of emergency equipment, e.g. high visibility vest, warning triangle, first aid boxes etc., complete and accessible?
- Are all emergency hammers in their correct positions?
- Are all fire extinguishers in place and in a serviceable condition?
- Are the vehicle tools and jack ready for operation and accessible?
- Are the seat belts in good condition and working properly?

#### Before starting the HV system

- Are fresh oil marks noticeable underneath when walking around to check the vehicle? This is an indication of leaks from individual systems.
- Is the vehicle exterior lighting in good working order?
- Are all signalling devices, e.g., hazard warning lamps, horn, and the headlight flasher, working properly?
- Are the headlights, lamp lenses, mirrors, and windows clean?
- Are the tyre treads and sidewalls undamaged? Check the spare wheel too (if vehicle is equipped with it)?
- Is there enough fluid in the windscreen washer system reservoir? ( ↻ 10.1.5, page 97).
- Is the coolant at the correct level? ( ↻ 10.1.3 page 95).
- Is the fluid level for the steering hydraulic system correct? ( ↻ 10.1.4 page 96).
- Is the engine compartment flap and are all service flaps closed and locked?
- Have all mirrors been adjusted to the requirements of the driver?
- Is the driver's seat adjusted correctly to the driver's height and weight?
- Are the vehicle documents, e.g., vehicle registration certificate, vehicle data card, etc. onboard?
- Has the driver card been inserted correctly in the tachograph?
- Is any damage visible or are there any loose objects in the passenger compartment? If so, repair the damage and remove the loose objects.

### 7.4.7 After starting the HV system

- After starting, do all check lamps turn off in the check lamp block?
- Are the brake pressures adequate? The "reservoir pressure" symbol in the driver's display must disappear. The reservoir pressure in the compressed air system must be at least 6 bar.
- Is the steering play OK (i.e., not excessive)? The front wheels must move once the steering wheel is turned by 30 millimetres (measured around the steering wheel circumference).
- Have all priority 1 and 2 malfunctions and fault messages disappeared?
- Is the tachograph working properly?
- Is the traction battery state of charge (SoC) sufficient?

The vehicle is only safe to operate once all the points have been checked.

### 8.2.2 Starting the high voltage (HV) system

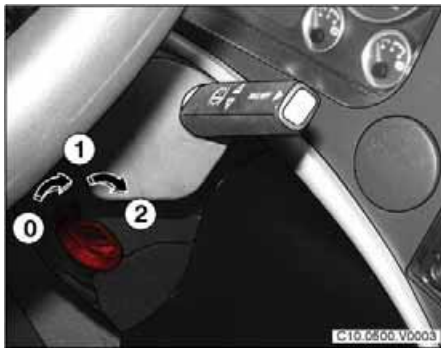

#### Preparations – Switching on ignition



---

It is essential for the operating safety of the vehicle to be checked before the HV system is started.



---

To start the HV system and enable the vehicle to enter “D” or “R”, the following flaps must be closed:

- Engine compartment flap

Make the following preparations before starting the HV system:

- ▶ Apply the parking brake.
- ▶ Insert ignition key in position ①.
- ▶ Turn ignition key to position ① - ignition is switched on.
- ▶ Position ② is not in use.

#### Function test with vehicle ready for operation

The vehicle's electronics system carries out a function test initially after the ignition is switched on. All check lamps and display instruments are activated for approx. 5 seconds during this function test.





---

The brake pressures will now start to build up if they were initially too low. Only drive-off once the necessary pressures have been reached.



---

When the HV system is started, the day driving lights are also switched on.



**Risk of accident**

If the necessary operating pressures do not build up, the vehicle cannot be driven.

Switch off the HV system.

Have the cause determined and rectified.



---

Observe the symbols and check lamps in the driver's display as soon as the HV system has started.

Do not drive off if, after the HV system is started, the red central warning lamp remains lit, and priority 1 fault messages are still displayed. Determine cause and rectify fault.

**Action to be taken if vehicle is not ready for operation**



**Risk of accident**

Priority 1 malfunctions and fault messages mean that operational and road safety is jeopardised.

Do not drive off.

Switch off the engine.

Have the cause determined and rectified.

The brake pressures are often too low after the vehicle has stood unused for some time. They must first be built up to the correct level. Symbols and check lamps may also appear in the driver's display, indicating that the vehicle is not yet ready for operation.

Do not drive off if priority 1 and 2 malfunctions and fault messages are displayed. The vehicle cannot be driven until all symbols have disappeared.



Priority 2 malfunctions and fault messages mean that operational safety is jeopardised. Do not drive off. Rectify the cause of the malfunction immediately or have it rectified at a Eurabus-approved service centre. If the vehicle is roadworthy and safe to drive, continue the journey without passengers to the next Eurabus-approved service centre.



Priority 1 and 2 malfunctions and fault messages → 7.4.7 page 51 and → 7.4.8 page 52.



Switch off HV system immediately in the event of the following:

- Abnormal rise in coolant temperatures.
- Sudden unusual noises from any rotating parts.

### Display of operational readiness

The vehicle is ready for operation as soon as all malfunctions, fault messages and the central red warning lamp turn off in the driver's display.

### Testing service brakes



#### Risk of accident

If the braking system is not working in the correct manner, severe accidents could ensue.

After driving off, carry out a brake test at low speed.

After driving off, carry out a brake test on a dry road with good traction. The brakes are in good working order if the wheels brake evenly and sufficient deceleration is achieved.

This simple, intuitive test is sufficient for practical driving operations.

### Reversing

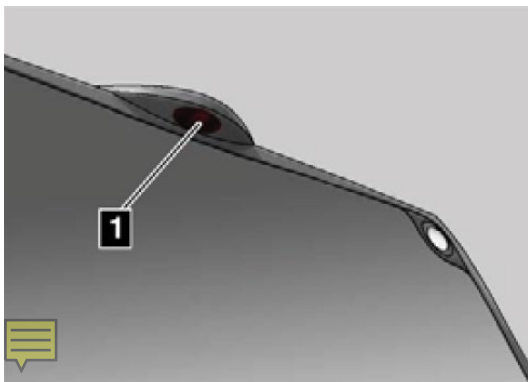



The reversing camera is intended as a driving aid only.

It does not absolve the driver's responsibility of paying special care and attention when reversing. People and objects are at risk when the vehicle is being reversed. Therefore, always observe the vehicle's immediate surroundings when manoeuvring.

Because of its design, it is not possible to have a full view of the area behind the vehicle.

Children playing beyond the reversing camera's range of view could be injured.

- ▶ Bring vehicle to halt.
- ▶ Engage reverse gear (↻ 8.2.3 page 59)
- ▶ Actuate accelerator pedal and release brake at the same time.

### Reversing camera

The reversing camera allows the driver to view the area immediately behind the vehicle.

- ▶ Engage reverse gear (↻ 8.2.3 page 59).

The area behind the vehicle is shown on the monitor in the cockpit (↻ 5.4.3 page 33).



---

When reverse gear is engaged, a clearly audible (also from outside vehicle) buzzer sounds.

### 8.2.3 Driving direction selection

- ▶ Press the brake pedal and keep it pressed, until the new gear selection is valid.
- ▶ Push “D” for driving forward or “R” for driving reverse.
- ▶ Push “N” for bringing the vehicle into neutral.

### Braking and Stopping

- ▶ Bring the vehicle to a halt using the service brakes.
- ▶ Switch driving direction selector into neutral position.
- ▶ Hold vehicle using service brakes; engage parking brake if necessary.

### Parking the vehicle

- ▶ Apply the parking brake.
- ▶ Switch off the HV system and remove the ignition key.
- ▶ If necessary, secure the vehicle with wheel chocks to prevent it from rolling away.



---

Parking vehicle (↻ 8.6.1, page 70)

## 8.3 Driving systems

### 8.3.1 Electronically controlled braking system (EBS)

EBS increases road safety by shortening the stopping distance and offers improved vehicle stability during braking manoeuvres. Extensive monitoring functions as well as brake pad/lining wear indication offer an effective means of maintenance management.

The electronically controlled braking system combines several functions, e.g.:

- Anti-lock braking system (ABS)
- Anti-skid regulation (ASR)
- Electropneumatic braking system (EPB)
- Frequent-stop brake.
- Easy Start drive-off aid (on AS-Tronic transmission only)
- Drag torque control (SMR)
- Brake-lining wear control
- Retarder/intarder integration
- Deceleration control and brake force distribution

#### Anti-lock braking system (ABS)

ABS prevents the wheels from locking when the vehicle's brakes are applied. This occurs whatever the nature of the road surface. When ABS is activated, the vehicle remains steerable, and its directional stability is retained.



#### Risk of accident

ABS is unable to compensate for driving too closely to the vehicle in front, driving at an inappropriate road speed or cornering too fast.

Therefore, adapt the vehicle's speed and the driving style to the actual traffic and road conditions.

ABS cannot reduce the stopping distance but can significantly increase driving and directional stability when braking.

Under certain circumstances, the stopping distance may be longer on gravel, snow, and slippery roads.

If the ABS system fails, active braking is maintained but braking performance changes.

Have malfunctions in the braking system rectified immediately at a EURABUS-approved service centre.



If ABS regulation occurs while the vehicle is being decelerated by the retarder, the retarder will be switched off immediately.

## Anti-skid regulation (ASR)

ASR regulates the drive torque of the driven wheels depending on the current driving situation. This improves traction on slippery, loose surfaces and maintains the directional stability of the driven wheels.

## Frequent-stop brake

The frequent-stop brake is applied at road speeds below 3 km/h by actuating one or more functions:

- Pressing button in instrument panel.
- Opening one of the doors.

The frequent-stop brake is released when none of the functions are active anymore and the accelerator pedal is depressed.



---

Releasing frequent-stop brake in an emergency  **8.5.2 page 65ff.**

Frequent-stop brake  **8.5.2 page 65ff.**

## Electropneumatic braking system (EPB)

### *Deceleration control and brake force distribution*

Deceleration control adapts the brake pressure to the deceleration requirements of the driver. When pressure is applied to the service brake pedal, the vehicle is braked by the same degree irrespective of the vehicle's load condition.

If deceleration of the vehicle deteriorates (e.g., because of brake fading when driving downhill), deceleration control is deactivated as soon as a preset maximum value is reached. The driver is then able to perceive deterioration of the braking effect subjectively.

Deceleration control also allows the brakes to be released as quickly as possible.

Brake force distribution to the front and rear axles is controlled in such a way that the brake pressures at the axles are optimised.



---

The Easy Start drive-off aid is only available on vehicles with semi-automatic AS-Tronic transmission ( 8.5.2page 65).

## Retarder/intarder integration

The retarder is integrated in the EBS. If the service brake pedal is depressed, the retarder is activated and controlled according to the deceleration requirements of the driver.

This optimises wear of the service brake.

## Brake assist system (BAS)

The brake assist system is integrated in the EBS. The electronics of the brake assist system automatically detect emergency braking situations when the service brake pedal is depressed very quickly, or the vehicle speed drops very suddenly. In the event of emergency braking, the system builds up maximum brake pressure thus shortening the stopping distance of the vehicle. ABS prevents the wheels from locking when the brakes are applied.



### Risk of accident

BAS is unable to compensate for driving too closely to the vehicle in front, driving at an inappropriate road speed or cornering too fast.

Therefore, adapt the vehicle's speed and the driving style to the actual traffic and road conditions.

## Electronic stability program (ESP)

ESP is an active safety system in the vehicle which improves driving safety and driving stability. It contributes significantly towards preventing the vehicle from skidding in corners or avoiding obstacles.

The brake force at each wheel is controlled individually in critical driving situations, e.g., when the vehicle is being driven on bends at its stability limit.

The engine power output is reduced at the same time.

Fine adjustment of the brake power prevents the vehicle from breaking away.

If the vehicle enters a critical driving condition in long bends or when making sudden lane changes, the vehicle speed is automatically reduced until driving stability has been regained.

A symbol appears to indicate that ESP is active.



### Risk of accident

ESP cannot extend the physical limitations of the vehicle.

Driving speed, correct behaviour when making obstacle avoidance manoeuvres and cornering speed remain the responsibility of the driver.

Therefore, adapt the vehicle's speed and the driving style to the actual traffic and road conditions.

## 8.4 Multi-function lever

### 8.4.1 Operating multi-function lever

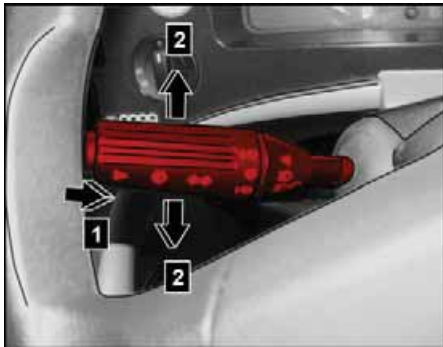

The multifunction lever is mounted on the left-hand side of the steering wheel. This lever is used to operate the main beam headlights, the headlight flasher, the turn signals, the horn, and the windscreen wipers.

All the multifunction lever functions (except for the headlight flasher) require the ignition to be switched on.

#### Switching on main beam headlights

- ▶ Switch on headlights.
- ▶ Pull multi-function lever over resistance in direction of **1** until lever engages in detent position.

The blue main beam check lamp lights up.

#### Activating headlight flasher function

- ▶ Pull multi-function lever against resistance in direction of **1** (towards steering wheel) and release again.

#### Turn signals

- ▶ Press or pull multi-function lever in direction of **2** over resistance.

The green turn signal check lamp flashes.



---

When changing lanes, push or pull the lever/stalk only as far as the resistance point and then release it again.

### Actuating horn

- ▶ Press button **3** briefly.

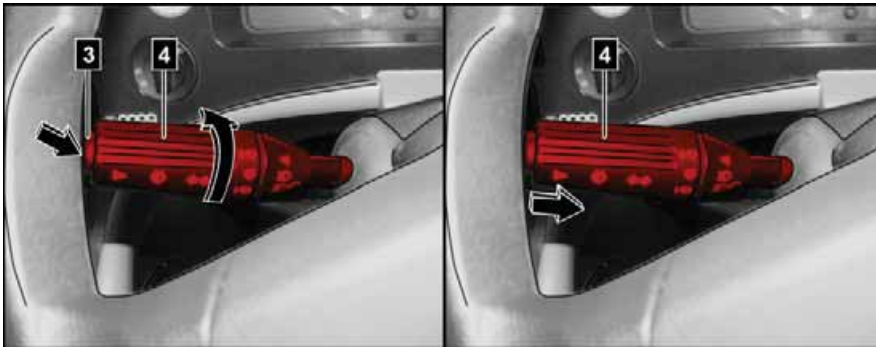

### Switching on windscreen wipers

- ▶ Turn lever sleeve **4** to desired position depending on intensity of rain.

**0** Windscreen wipers OFF

***Intermittent wipe***

**I** Slow wipe

**II** Rapid wipe



---

Renewing damaged wiper blades  **10.1.6 page 98.**

### Cleaning windscreen

- ▶ Press lever sleeve **4** in direction of steering column and hold.

The windscreen wipers continuously wipe the windscreen with washer fluid. When the lever sleeve is released, the wipers wipe the windscreen three more times without washer fluid.



## 8.5 Braking

### 8.5.1 Service brakes



The service brakes of the vehicle are regulated by ABS. Intervention by the ABS in a braking operation can be felt as pulsations at the service brake pedal **1**.



To make an emergency stop, depress the service brake fully to achieve the maximum braking effect. ABS prevents the wheels from locking.



If the brakes have been used excessively, do not stop the vehicle immediately but continue driving for a short time. This allows the airflow to cool the brakes down.

Utilise the braking effect of the engine on downhill sections by shifting down to a lower gear.

Activate the retarder.

The braking effect may fade after prolonged driving in rainy conditions. It is therefore important to depress the service brake pedal slightly at regular intervals.

The Voith retarder can be actuated by pressing the service brake pedal (  **8.5.1, page 65**).

### 8.5.2 Frequent-stop brake (FSB/Auto hold)



#### Risk of accident and injury

The FSB operates at a lower pressure than the parking brake. The vehicle could roll away depending on the upward or downward gradient.

Therefore, apply the parking brake in addition at bus stops on gradients greater than 10 %.

The FSB cannot hold the vehicle stationary for a long time. Do not use the FSB as a parking brake. Do not leave the vehicle unattended with the FSB engaged. The vehicle could otherwise roll away. Persons could fall, become trapped and sustain injuries caused by crushing. Always apply the parking brake before exiting the vehicle.

The hill-hold function is also deactivated when the FSB is released. It can only be reactivated by repeating the steps described below.

The FSB has a lower pressure requirement than the parking brake. Therefore, use the FSB as much as possible at bus stops on level road surfaces.

When the FSB is released, the hill-hold function is activated until the accelerator pedal is pressed.

The hill-hold function stops the vehicle from rolling back during drive-off.



---

If the vehicle is brought to a halt with ABS intervention, the brake pedal must first be released before the frequent-stop brake can be engaged.

### Applying and releasing FSB automatically

- ▶ Bring vehicle to halt.
- ▶ Open the doors.

The FSB is activated, and the vehicle is held stationary. The frequent-stop brake control lamp lights up as confirmation.

- ▶ Close the doors.

The FSB is deactivated. The hill-hold function holds the vehicle to stop it from rolling back until the accelerator pedal is pressed.

- ▶ Engage a gear and depress the accelerator pedal.

The hill-hold function is deactivated, and the vehicle pulls away. The frequent-stop brake control lamp goes out.



### Applying / releasing FSB manually

#### Applying FSB

- ▶ Press button **1**.

The FSB is activated, and the vehicle is held stationary. The frequent-stop brake check lamp and the lamp in the switch light up to indicate the function.

### Releasing FSB

- ▶ Press button  again.

The FSB is deactivated. The hill-hold function holds the vehicle to stop it from rolling back until the accelerator pedal is pressed.

- ▶ Engage a gear and depress the accelerator pedal.

The hill-hold function is deactivated, and the vehicle pulls away. The frequent-stop brake and the lamp in the switch go out.



---

Releasing frequent-stop brake in an emergency  **8.5.2, page 65f.**

### 8.5.3 Retarder/virtual retarder

The retarder can be activated at any speed, except when the vehicle is stationary. The retarder is activated with the service breaks or the hand lever on the steering column.



#### Risk of accident and injury

The retarder acts on the driven wheels of the vehicle. The driven wheels can lock on slippery roads causing the vehicle to skid. This is why the retarder should not be used in wintery conditions.

The retarder cannot keep the vehicle stationary. Therefore, use the parking brake or service brake when stationary. Always apply the parking brake before exiting the vehicle.

The retarder has a lower braking power than the service brake. Always apply the service brake in emergency situations.



---

Excessive use of the retarder can lead to hardening of the brake lining and vitrification of the brake disks. If the braking effect of the service brakes diminishes, have the service brakes checked at a EURABUS-approved service centre.



---

See also operating instructions issued by the retarder manufacturer.



---

A warm-up function is active up to a certain coolant temperature. Simultaneous operation of the retarder and accelerator pedal is then possible.

It is possible to change gear at any time when braking with the retarder. Braking power is maintained even during gear shifting.

Reduction of the retarder braking power begins at a certain coolant temperature. The braking power is reduced with infinite variability. In this case, shift down and, if necessary, also operate the service brakes.

Make sure that the engine speed does not drop below 1600 rpm during retarder operation.

To prevent premature reduction of the retarder braking power, the water pump must operate at a sufficient delivery rate. The engine speed can be increased to the maximum permissible speed of approx. 2200 rpm by changing down, especially on long downhill stretches.



### Actuating retarder with service brake pedal

The retarder can be activated over the whole brake pedal range with infinite variability. The braking power of the retarder depends on the position of the brake pedal.



### Risk of accident

Retarders only generate a low braking power at very low vehicle speeds. Therefore, use the service brakes in addition when driving slowly.



At very low outside temperatures, the braking effect is delayed the first few times the retarder is used.

### Activating retarder

- ▶ Press service brake pedal **1** until required braking effect is reached.



## Actuating retarder with hand lever



### Risk of accident

Retarders only generate a low braking power at very low vehicle speeds.

Therefore, use the service brakes in addition when driving slowly.



At very low outside temperatures, the braking effect is delayed the first few times the retarder is used.

## Activating retarder

- ▶ Move lever **1** in the direction of + (retarder stage 1) once to activate the recuperation/regeneration function.

If retarder stage 1 is set at a speed that is currently being driven, the speed of the vehicle is maintained at overrun via the retarder. If in this case the accelerator pedal is pressed, the speed to be maintained is set higher accordingly.

- ▶ Move lever **1** in the direction of + or – continually until the desired braking effect is reached.



There are 5 braking levels.

Each step in the + or – direction results in the retarder's braking performance advancing or retarding one level. Braking levels 2 to 5 request a predefined braking torque.

The current braking level is shown next to the retarder symbol in the driver's display.

## 8.6 Parking

### 8.6.1 Engaging parking brake, parking vehicle

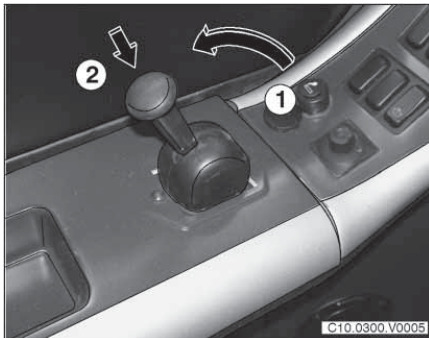

#### Risk of injury

Additional precautions must be taken when parking the vehicle on a gradient.

Place wheel chocks under the wheels to prevent the vehicle from rolling away. Turn the steering wheel towards the kerb.

Persons could fall, become trapped and sustain injuries caused by crushing.

Do not leave the vehicle with the engine running and a gear engaged. The vehicle could roll away.



#### Risk of fire

High temperatures at exhaust system components can ignite highly inflammable materials located under the vehicle.

The vehicle should therefore never be parked over highly flammable materials either with the engine idling or switched off.

Always apply the parking brake when the vehicle is parked.

#### Parking vehicle

- ▶ Actuate service brakes and shift transmission to N position.
- ▶ Pull the parking brake lever out of the released position (1) into the fully braked position (2).

The lever engages and the vehicle is prevented from rolling away. The "parking brake" check lamp lights up.

- ▶ Switch off the air conditioning system.
- ▶ Switch off all electrical consumers.
- ▶ Switch off the engine and remove the ignition key.

- ▶ Turn the steering wheel until the lock engages (not on special models without a steering lock).
- ▶ Lock the vehicle.
- ▶ If necessary, secure the vehicle with wheel chocks to prevent it from rolling away.

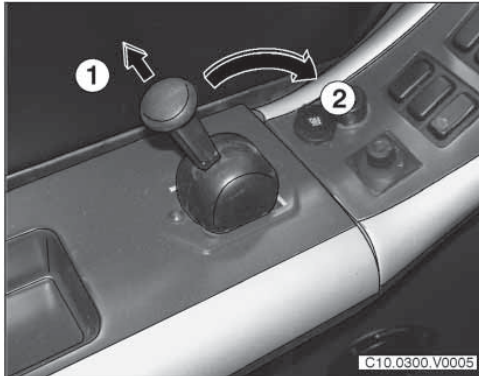

### Releasing parking brake



#### Risk of fire

If the "parking brake" check lamp lights up when the parking brake is released, despite adequate brake reservoir pressure, there is a fault in the spring actuator circuit.

The vehicle is not ready for operation. Have the braking system checked immediately at a EURABUS-approved service centre.



A reservoir pressure of at least 6 bar is required to release the parking brake. If this pressure is not reached, the brake linings may have slight contact. This can lead to overheating when the vehicle is in motion.

- ▶ Remove any wheel chocks.
- ▶ Actuate service brakes.
- ▶ Pull the lever out of its engaged position (1) and move it to the released position (2).

## 8.7 Charging

### 8.7.1 Charging



The traction battery can be charged using a CCS2 gun, running the ISO 15118 protocol.

The vehicle can be equipped with either one or two charging ports, to double the charging power and reduce the charging time.

#### **To start the charging, follow those steps:**

- ▶ Move the vehicle to a proper charging station (min. 600V)
- ▶ The charging gun should be easy to plug to the vehicle inlet, do not bend the wire.
- ▶ Apply the parking brake.
- ▶ Insert the charging gun into the vehicle.
- ▶ If required, authorize the charging process at the station by using a key, a RFID card, an app or whatever the operator offers.
- ▶ Check, if the station shows successful handshake and charging power (typically 50-120kW)
- ▶ The charging status is also shown in the driver display once the process started.

#### **To stop the charging, follow those steps:**

- ▶ Push the stop button at the charging station.
- ▶ In case of emergency, push any of the HV system emergency stop buttons (page xxx)
- ▶ Wait for the vehicle to stop the charging process and unlock the charging gun.
- ▶ Remove the gun and gently put it back into the charging station bracket, to prevent driving over the charging wire.

### 8.7.2 emergency release of charging gun

In case of sudden power loss of the vehicle 24V system or a software freeze between charging station and vehicle, it may happen, that the charging gun is permanently locked, and the locking motor does not move.

It is possible to move the locking pin with careful manual force, pulling the emergency sling close to the charging port.



## 9 Practical advice

### 9.1 Towing

#### 9.1.1 Safety precautions on towing



#### Risk of accident

Towing the vehicle with a rope or similar device could lead to rear-end collisions. Therefore, only tow the vehicle using a tow bar.

Do not tow the vehicle if the steering is damaged. The vehicle cannot be manoeuvred. In the event of steering damage, raise the front of the vehicle with a recovery vehicle to tow.

Always tow slowly and with extra caution.

Only tow the vehicle when empty.

Ask all passengers to leave the vehicle before towing. Make sure that there are no passengers left in the vehicle.



Switch on the hazard warning lamps of both vehicles for own safety and to warn others.

Observe the road traffic regulations for towing. If possible, keep the engine running when the vehicle is being towed. This supplies the power-assisted steering system and the braking system with compressed air. The power assisted steering will not work if the HV system is not running. More steering force must then be exerted.

Release the spring actuators mechanically if there is no pressure in the compressed-air system (↪ **9.2.1, page 78**).

Risk of transmission damage! Always remove the prop shaft before towing the vehicle (↪ **9.1.5, page 76**).

#### Preparatory measures

- ▶ Request passengers to exit vehicle. Make sure that there are no passengers left in the vehicle.
- ▶ Prepare the front coupling jaw (↪ **9.1.2 page 74**).
- ▶ Remove prop shaft (↪ **9.1.5, page 76**).



#### Risk of accident

If the HV system is not running, the power-assisted steering will fail and after a short time the service brake will also fail.

The vehicle cannot be manoeuvred safely. Raise the front of the vehicle using a suitable recovery vehicle and tow it away.

- ▶ Start the HV system so that power steering support is provided, and the service brakes are charged with air.
- ▶ If the batteries are discharged and the HV system cannot be started, start the HV system using slave leads (↪ **9.4, page 84**) or spare batteries.
- ▶ Mechanically release spring actuators (↪ **9.2.1, page 78**) or charge the compressed air system from an external source (↪ **9.2.2, page 79**) if the reservoir pressure in the compressed air system is inadequate.
- ▶ Fit tow bar, insert pin from above and secure with split pin.



Fans, air conditioning systems, lighting, etc. require a large amount of electrical power. They could completely discharge the batteries within just a few hours. It is particularly important to remember this when towing the vehicle with the HV system switched off.



See also the towing regulations from the engine and axle manufacturers.

### 9.1.2 Front towing

The towing eye can be found behind the penultimate service flap on the front.



#### Risk of accident

The vehicle could start to move uncontrollably, and persons could become trapped.

Before screwing in the towing eye, take measures to prevent the vehicle from rolling away. Apply the parking brake. Place wheel chocks under the wheels.



For your own protection and to warn others, wear high visibility vest!

Take precautions to prevent the vehicle from rolling away.

- ▶ Fold down front service flap.
- ▶ Remove trim carefully and place safely to one side.
- ▶ Connect tow bar to towing eye.

### 9.1.3 Towing buses with defective engine or transmission



---

Always detach the prop shaft if engine or transmission damage is suspected.

- ▶ Remove prop shaft (→ **9.1.5, page 76**).
- ▶ Insert tow bar, insert pin from above and secure with split pin.
- ▶ Switch on ignition, turn on HV system if possible.
- ▶ Shift the traction inverter to neutral position.



---

See also the operating instructions from the engine and axle manufacturers.

### 9.1.4 Towing buses with axle and steering damage

#### Damage to front axle and steering



---

Both sides of the swing axle must be at full rebound before the vehicle is towed. The front wheels should not turn while the vehicle is being towed. Make sure that the rear of the vehicle cannot bottom out while it is being towed.

- ▶ Remove prop shaft (→ **9.1.5, page 76**).
- ▶ Raise the front of the vehicle with the recovery vehicle to tow it away.

#### Damage to rear axle



---

The rear wheels should not rotate while the vehicle is being towed. Make sure that the front of the vehicle cannot bottom out while it is being towed.

Turn the front wheels to the straight-ahead position.

Fix the steering wheel in place using a tensioning strap. Raise the rear of the vehicle using the recovery vehicle and tow it away.



---

See also the operating instructions from the axle and steering manufacturers.

### 9.1.5 Removing prop shaft

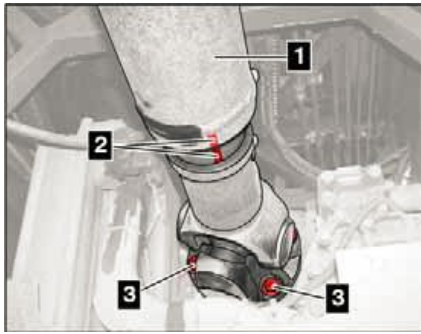

The prop shaft **1** must be removed completely to avoid damage to the traction inverter when the vehicle is being towed.



#### Risk of injury

Once the threaded connections **3** have been removed from the transmission flange and axle flange, the flange drive elements can be tilted downwards.

Fingers and hands could be crushed. Likewise, head injuries could be caused.

Never reach into the universal joint. Wear suitable head protection (approved hard hat).



Do not subject the prop shaft to impacts or knocks when removing it or placing it aside. The prop shaft could otherwise become imbalanced or bent.

- ▶ Take precautions to prevent the vehicle from rolling away. Chock wheels. (↪ **6.3.2, page 36**).
- ▶ Shift the traction inverter to neutral position. (↪ **8.2.3, page 59**).
- ▶ Raise vehicle
- ▶ Secure prop shaft **1** before removing to prevent it from coming apart and falling down.



When installing, the prop shaft parts must be inserted again correctly if they came apart during removal. Since the two parts of the prop shaft have been balanced to each other, there is a risk of imbalance if these instructions are not observed. This may damage the bearings on the traction motor and the drive axle.

- ▶ If necessary, mark each of the prop shaft parts with chalk or similar **2**.

In this way, the prop shaft parts can be inserted again correctly if they came apart during removal.

- ▶ Unscrew all threaded connections **3** on the transmission flange and axle flange.
- ▶ Remove prop shaft and place carefully to one side.



See the operating instructions issued by the manufacturer of the prop shaft for further information.

### 9.1.6 Recovering buses from rough terrain

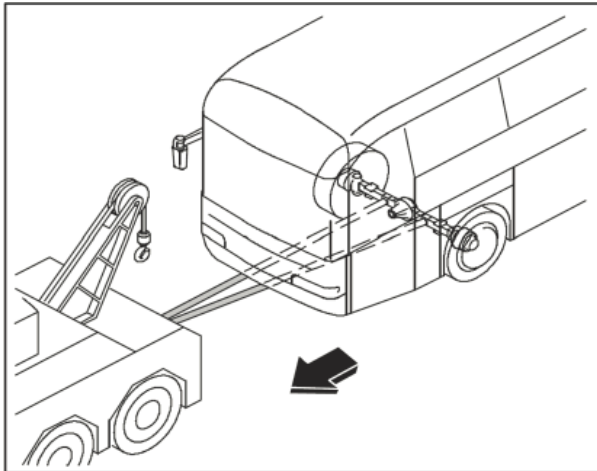

Before pulling the vehicle off rough terrain, always unload it to reduce its weight. If unloading is not possible for technical or practical reasons, towing lines must be attached to as many points as possible on the vehicle. The axles are ideal for this purpose.

The towing eyes are not suitable for recovery from rough terrain. They can only be loaded with a maximum towing force of 200 kN in the pulling direction.

The recovery of other vehicles from rough terrain using this vehicle is not permitted. The towing eyes and trailer hitches are not designed for such loads and the frame construction would suffer damage.

## 9.2 Loss of air pressure

### 9.2.1 Releasing spring actuators mechanically

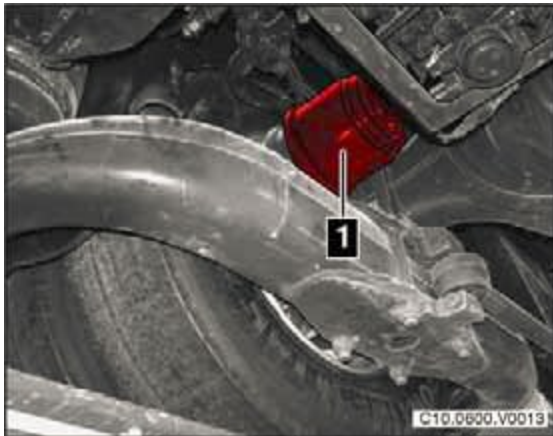

The spring actuators can be released mechanically in an emergency, e.g., for towing the vehicle or when there is insufficient air reservoir pressure.



#### Risk of injury

If the spring actuators are in the release position, the parking brake will have no braking effect. The vehicle is not ready for operation.

Persons could fall, become trapped and sustain injuries caused by crushing.

Before releasing the spring actuators, take precautions to prevent the vehicle from rolling away.

Place wheel chocks in front of or behind the wheels.



#### Risk of accident

It is essential for the spring actuator function to be restored before using the vehicle again. The vehicle is otherwise not ready for operation.

The spring actuators can be found on each side of the drive axle on the left and right brake calliper. The illustration shows the spring actuator on the right-hand side (relative to the direction of travel) with the wheels still mounted.



To enable access to the spring actuators, it is recommended that the vehicle is raised, and the wheels are removed.

## Releasing spring actuators

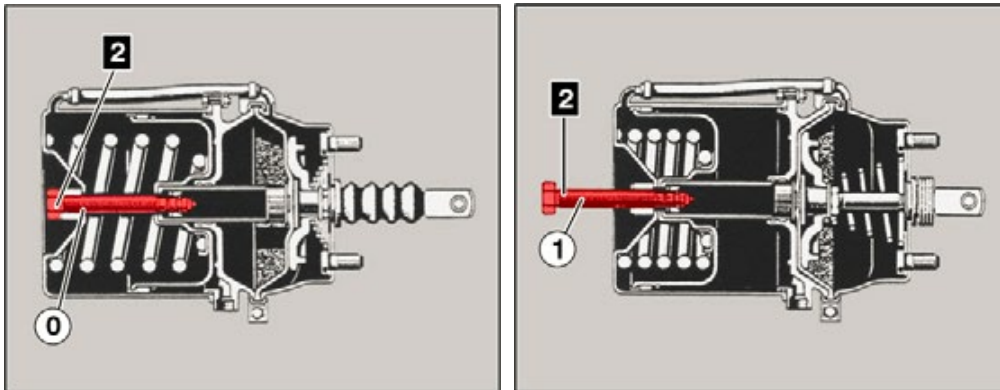

- ① Brake position
- ② Release position

- ▶ Secure the vehicle to prevent it from rolling away (↪ 6.3.2, page 36).
- ▶ Move the parking brake to the release position.
- ▶ Raise the vehicle if necessary.
- ▶ Unscrew release bolt 2 completely onto stop until release position ① is reached.

Max. release torque: 35 Nm

## Restoring spring actuator function



### Risk of accident

It is essential for the spring actuator function to be restored before using the vehicle again. The vehicle is otherwise not ready for operation.

- ▶ Pressurise the braking system up to the cut-off pressure.
- ▶ Screw release bolt 2 fully into braking position ① and tighten.

Tightening torque: 30 to 36 Nm.

- ▶ Check that the spring actuators are working properly; operate the parking brake several times.

## 9.2.2 Charging vehicle with air from external source



### Risk of accident

The vehicle could start to move uncontrollably, and persons could become trapped. Take precautions to prevent the vehicle from rolling away before pressurising the vehicle from an external source. Apply the parking brake. Place wheel chocks under the wheels.

A loss of air pressure after just a short standstill period indicates a leak in the compressed air system. The vehicle is not ready for operation. Have the vehicle checked at a Eurabus-approved service centre.

The external filling connection is behind the front-end centre flap.

If the air compressor fails, the vehicle compressed air system can be pressurised via the external filling connection.

- ▶ Take precautions to prevent the vehicle from rolling away.
- ▶ Remove cap of external filling connection.
- ▶ Connect the filling hose.
- ▶ Pressurise the compressed air system until a brake reservoir pressure of at least 6 bar is reached.

The central warning lamp and the air pressure check lamp turn off once air reservoir pressure is greater than 6.5 bar. The error message in the driver's display stating that reservoir pressure is too low also disappears.

### **9.2.3 Manoeuvrability of vehicle if air suspension is depressurized**

The chassis is designed to maintain vehicle manoeuvrability even if the air bags of the suspension are depressurised.

In this case, the entire weight of the vehicle will rest on the hollow rubber springs mounted on the front running gear and rear axle. The hollow rubber springs are not used during normal operation. They only prevent the running gear and the axles from bottoming out when the springs are subject to extreme compression.

The rubber hollow springs are not designed for continuous duty. They can never replace the standard suspension.



---

The vehicle remains manoeuvrable if the air suspension becomes depressurised. However, it should only be driven at walking pace to the nearest Eurabus-approved service centre.



## 9.3 Changing wheel

### 9.3.1 Changing wheel

#### Preparations

- ▶ Park the vehicle in a suitable and safe place.
- ▶ Switch off the ignition and switch on the hazard warning lights.
- ▶ Don high visibility vest.
- ▶ Place the hazard warning triangle and flashing warning light at an adequate distance from the vehicle. Observe national regulations.
- ▶ Request passengers to exit vehicle. Make sure that all passengers stay outside the danger zone.
- ▶ Take precautions to prevent the vehicle from rolling away. Apply the parking brake. Place wheel chocks under the wheels.
- ▶ Deactivate the ECAS system.

#### Deactivating ECAS system

The ECAS system continues to adjust the height of the vehicle for up to 10 minutes after the ignition has been switched off. Before changing the wheel, deactivate the ECAS system.



#### Risk of injury

The vehicle can slip off the jack when raised if the ECAS system attempts to adjust the vehicle height. Parts of the body could become trapped.

Never raise the vehicle with the ECAS system active. Switch off the battery isolating switch.

Never switch on the battery isolating switch and ignition while the vehicle is jacked up.

- ▶ Switch off battery isolating switch (👉 9.4.4, page 86).

#### Raising vehicle

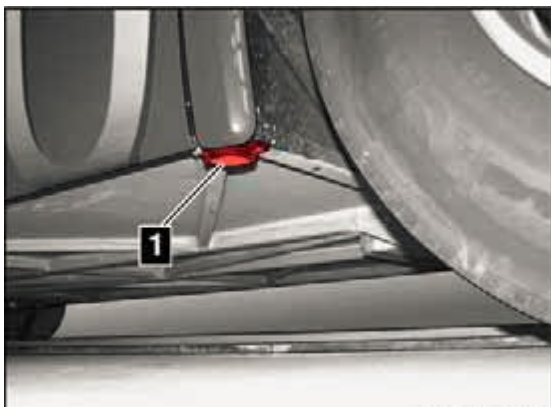

Jacking points 1 are provided on the vehicle body. The jacking points can be found behind each of the wheels.

The vehicle should only be jacked up at these points.



#### Risk of injury

If the vehicle jack is not in a secure position, it could slip or be forced into the ground. The vehicle could drop down uncontrollably and cause potentially life-threatening injuries.

- Only jack up the vehicle when it is on level ground. Make sure that the ground is firm and not slippery.
- Only raise the vehicle at the dedicated jacking points.
- Secure a jacked-up vehicle with axle stands where possible.
- Never lie under a vehicle which is not secured in this way.



#### Risk of accident

The ECAS system continues to adjust the height of the vehicle for up to 10 minutes after the ignition has been switched off. Deactivate the ECAS system before jacking up the vehicle (👉 page xxx).

Do not switch on the ignition when the vehicle is jacked up. The ECAS system would attempt to regulate the height of the vehicle above ground. This may cause the vehicle to slip off the jack, thus causing severe injuries and damage to the vehicle.

- ▶ Take precautions to prevent the vehicle from rolling away. Apply the parking brake. Place wheel chocks under the wheels.
- ▶ Switch off battery isolating switch (👉 9.4.4, page 86).
- ▶ Deactivate ECAS system (👉 9.3.1, page 81).
- ▶ If fitted, remove hub caps.
- ▶ Loosen and remove all wheel nuts, except for three-wheel nuts equally spaced around the rim.
- ▶ Place the jack at the jacking point provided on the body and raise the vehicle.



Avoid dragging the rims over the threads of the wheel bolts when removing the wheel. This would damage the bolt thread and it would then be difficult to screw on the wheel nuts. At worst, the wheel nut could even seize on the damaged bolt.

Keep spring lock washers and centring sleeves in a clean, safe place for later use.

### Removing wheel

- ▶ Make sure that the wheel is seated on the studs without tension.
- ▶ Loosen and remove the three remaining wheel nuts.
- ▶ Remove the wheel, or wheels if it is a double wheel.

## Mounting wheel



### Risk of accident

Heavily worn replacement tyres could lead to dangerous, unforeseeable driving properties. Renew spare wheel.



Only use tyres and rims which are approved for the vehicle.

Observe the tyre size, tyre load capacity and speed index (👉 **11.4, page 117ff**).

- ▶ Remove any rust and dirt from the contact surfaces of the wheel hub and rim. With double wheels, remove any rust and dirt from between the rims.
- ▶ Install wheel and screw on two-to-three-wheel nuts.
- ▶ Check that the wheel is seated centrally.
- ▶ Screw on remaining wheel nuts and tighten with wheel brace.
- ▶ Lower the vehicle.
- ▶ Tighten the wheel nuts to the specified torque in a crosswise sequence.
- ▶ Always check and, if necessary, correct the tyre pressure.

### Specified tightening torque

575 ± 25 Nm



### Risk of accident

Always make sure that the tyre pressures are correct.

Incorrect tyre pressure may lead to dangerous and unpredictable handling characteristics and to accidents.



Always tighten flat collar nuts in a crosswise sequence.

Observe the specified tightening torques.

Retighten the wheel nuts after approximately 50 kilometres after changing a wheel and on new vehicles.



Always check and, if necessary, correct the tyre pressure.

Tyre pressures 👉 **11.4.4 page 118**.

## 9.4 Slave starting / assisted starting the 24V system

### 9.4.1 Safety precautions for slave starting and assisted starting



#### Risk of injury

Fire, sparks, naked flames, and smoking are strictly prohibited when handling batteries.

Take extra care after prolonged driving or when charging batteries using a battery charger. The batteries produce highly explosive oxy-hydrogen gas - ensure good ventilation.

Avoid producing sparks when connecting / disconnecting electrical consumers or measuring instruments directly to/from battery terminals.

Batteries contain corrosive acid. Electrolyte could flow out of the vent openings. Always wear appropriate protective clothing, protective goggles, and acid-proof rubber gloves. Never tip batteries.

Always wear eye protection when performing work involving batteries.

Keep children away from batteries and battery acid.

Switch off all electrical consumers before connecting or disconnecting batteries.

Always disconnect the earth connection (-) first.

Avoid short-circuits caused by polarity reversal and by bridging terminals with tools or metal objects.

Only remove the terminal covers when necessary.

Always connect the earth connection (-) last when connecting the batteries.



Switch off battery isolating switch (↪ **9.4.4, page 86**).

### 9.4.2 Slave starting

The 24V batteries can be found in the rear-most right-side service flap.

- ▶ Switch off ignition of both vehicles.
- ▶ Open service flap (↪ **5.1.4, page 26**).
- ▶ Remove the cover from the battery poles.
- ▶ Fit cables to the battery poles.
- ▶ Start the engine or HV system of the donor vehicle.
- ▶ Connect the slave led to the donor vehicle.
- ▶ Start the receiving vehicle.
- ▶ Switch off the engine or HV system of the donor vehicle.
- ▶ First disconnect the slave lead from the receiving vehicle and then from the donor vehicle.

### 9.4.3 Assisted starting

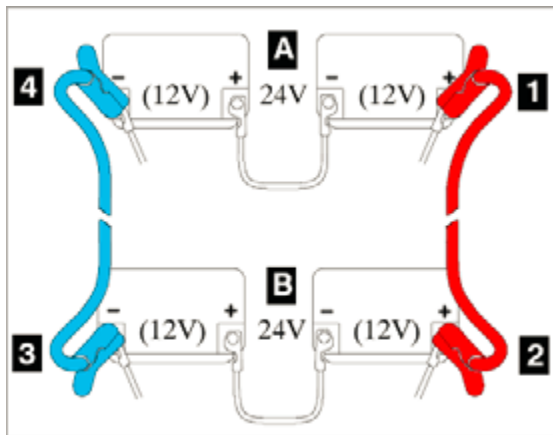

If the batteries are discharged and the engine cannot be started, an alternative is replacement batteries or the batteries of a donor vehicle.

**A** Batteries of receiving vehicle.

**B** Batteries of donor vehicle.



Connect the slave leads to the battery terminals only - never connect them to the starter or frame. Control units could otherwise be damaged.

Do not start the vehicle using a battery charger. Battery chargers are not designed for this purpose. Only use standardised slave leads designed for this purpose.

Make sure that both vehicles operate at the same operating voltage before connecting the slave leads.

#### Connecting slave lead

- ▶ Switch off ignition of both vehicles.
- ▶ Switch off battery isolating switch (☞ 9.4.4, page 86).
- ▶ Connect the first terminal clamp 1 of the red cable to the positive terminal of the receiving battery.
- ▶ Connect the second terminal clamp 2 of the red cable to the positive terminal of the donor battery.
- ▶ Connect the first terminal clamp 3 of the black cable to the negative terminal of the donor battery.
- ▶ Connect the second terminal clamp 4 of the black cable to the negative terminal of the receiving battery.
- ▶ Start the engine or HV system of the donor vehicle. Run the engine at a slightly higher speed.
- ▶ Switch on the battery isolating switch again.

#### Disconnecting slave leads

- ▶ Remove the terminal clamps in reverse order.

## 9.5 Mechanical battery isolating switch

### 9.5.1 Isolating electrical system from battery

The electrical system can be disconnected from the battery using the battery isolating switch if the vehicle is to be taken out of service for a period of time or before repair work is started.

The battery isolating switch is located behind the service flap next to the batteries.



---

Do not switch off the battery isolating switch if:

- The HV system is still active.
- Any other electrical consumers are still switched on.

The vehicle electrical system and its control units could otherwise be damaged.

#### Disconnecting battery from electrical system

- ▶ Switch off the ignition.
- ▶ Open service flap (↪ 5.1.4, page 26).
- ▶ Turn battery isolating switch in the OFF position.

The vehicle's electrical system is now disconnected from the battery.

#### Connecting battery to electrical system

- ▶ Open service flap (↪ 5.1.4, page 26).
- ▶ Turn battery isolating switch in the ON position.

The vehicle's electrical system is now connected to the battery.

## 9.6 Overview of lamps

### 9.6.1 Overview of vehicle exterior lights

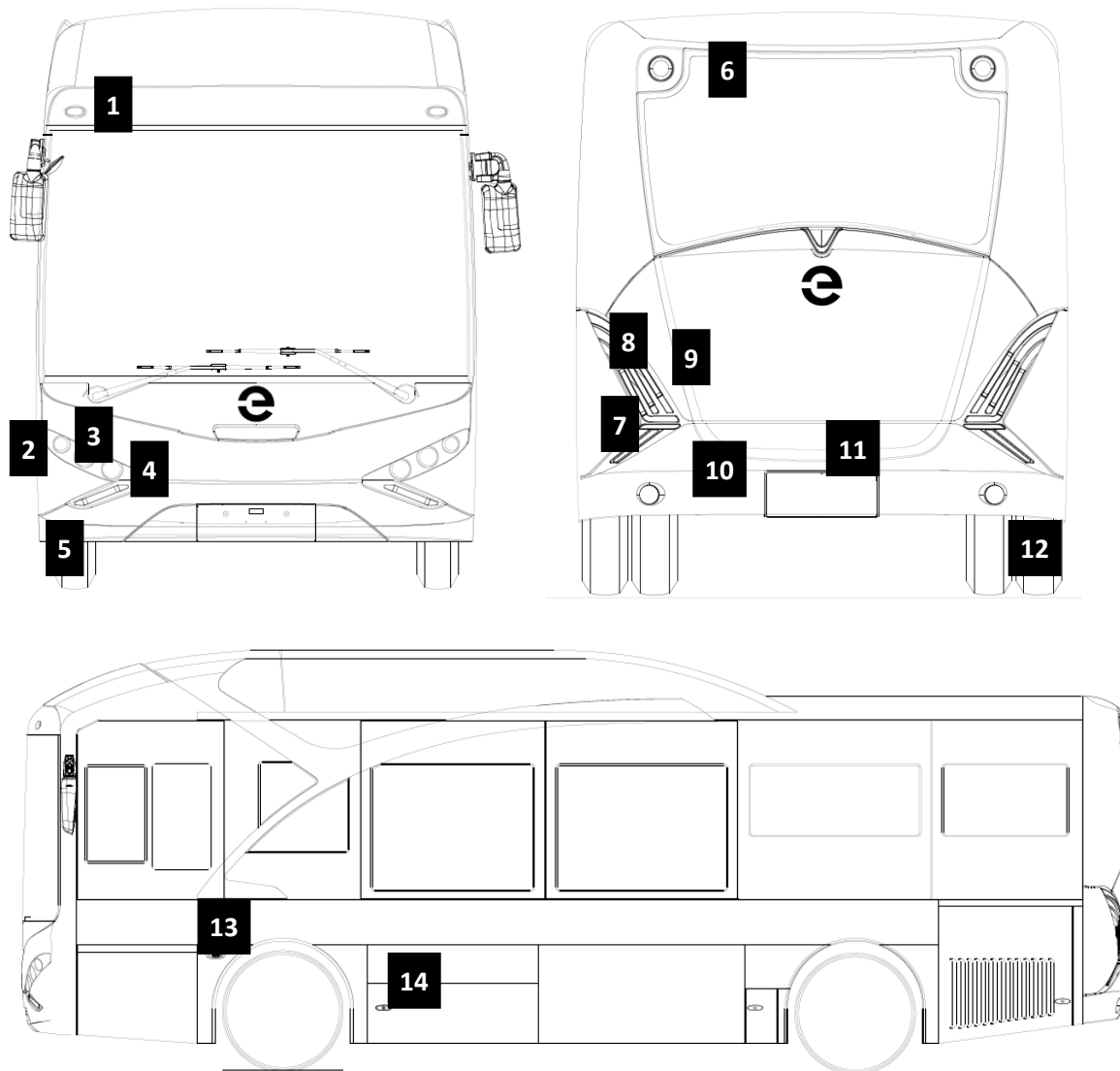

Item	Designation	Light source
1	top position light	LED
2	turn signal/indicator	LED
3	low/high beam	LED
4	fog light	LED
5	DRL + position light	LED
6	Upper turn signal/ brake light/taillight	LED
7	taillight	LED
8	turn signal/indicator	LED
9	brake light	LED
10	reflector	LED
11	license plate light	LED
12	reverse light/fog light	LED
13	turn signal/indicator	LED
14	side marking lights	LED

## 9.7 Changing fuses

### 9.7.1 Changing fuses or relays



#### Risk of fire and injury

Electric shocks can cause injury and start a fire in the electrical system. Switch off all electrical consumers before fitting a new fuse.

Do not bridge, repair, or replace fuses with those of incorrect ampere rating. This could cause a fire in the electrical system.



---

Rectify the cause of the short circuit before changing a blown fuse.

Before commencing any repair work on the electrical system, switch off all consumers and switch off the battery isolating switch (→ **9.4.4, page 86**).

- ▶ Switch off all electrical consumers and ignition.
- ▶ Enable access to the relevant switch panel.
- ▶ Locate the cause of the short-circuit or overload and rectify the fault.
- ▶ Remove the blown fuses or relays and replace with fuses or relays that have the specified rating.



---

The specified ratings of the individual fuses and relays are given at various locations:

- Assignment diagrams located on switch panel covers.
- Assignment diagrams located next to fuse blocks.



## 9.7.2 Fuses and relays in switch panel at rear of vehicle

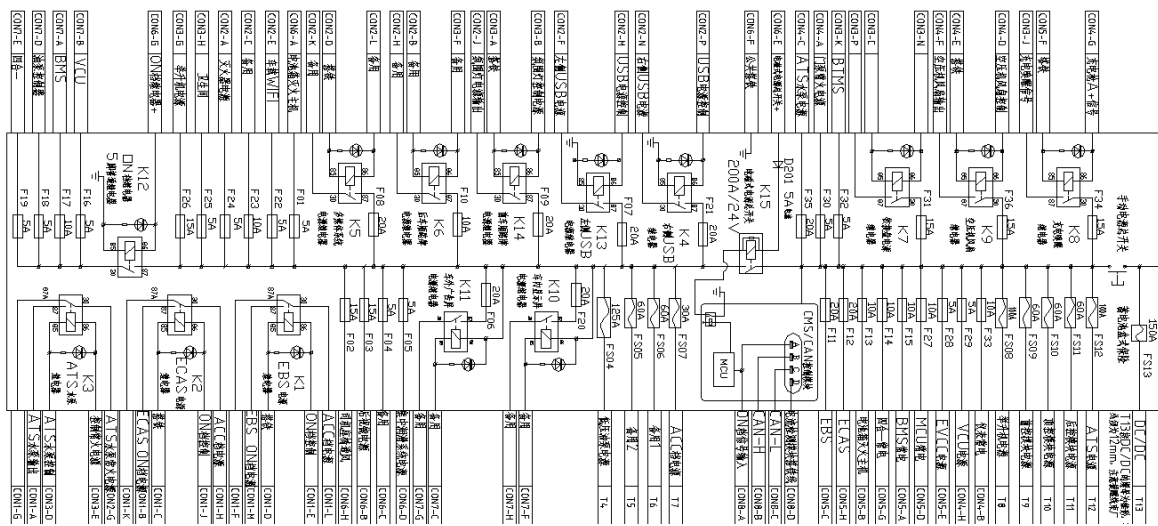
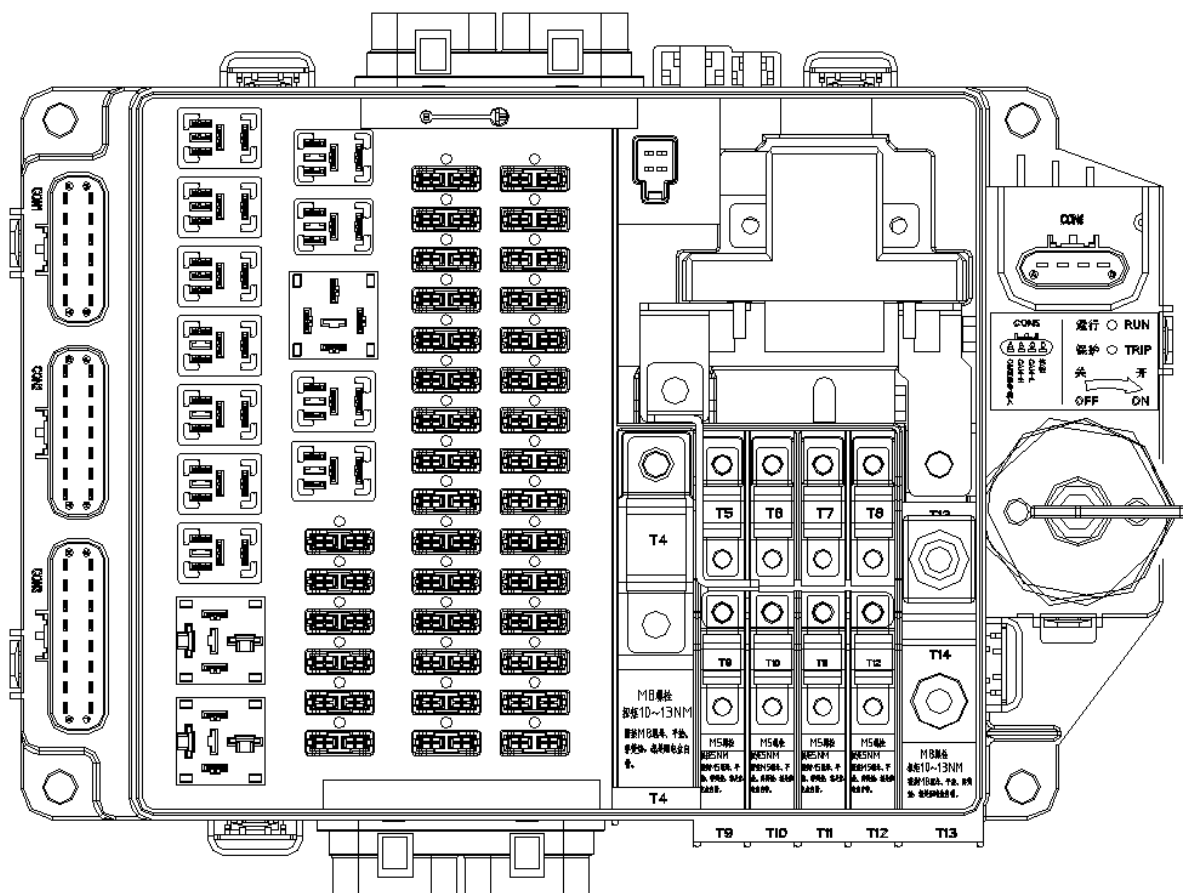

## 9.8 Troubleshooting

### 9.8.1 Troubleshooting

#### Driving personnel

This guide includes tips and instructions which should help to rectify faults that may occur on the vehicle. This will at least allow the vehicle to be driven to the next Eurabus-approved service centre.

If a fault appears in the driver's display or a check lamp lights up, begin by reading the appropriate section in these operating instructions.

To ensure that the cause of the fault was properly found and rectified, seek advice from a Eurabus-approved service centre.



Recommended remedial action, to be carried out only by properly trained personnel  
 ↪ page xxx.

#### HV system and traction system

Malfunction	Possible cause	Recommended remedial action
HV system does not start but 24V is active (e.g., driver display)	Low 24V battery (<21V)	<ul style="list-style-type: none"> <li>▶ Charge battery.</li> <li>▶ Slave start vehicle (↪ 9.4.2 page 84).</li> </ul>
	Low high voltage battery (SoC <0%)	<ul style="list-style-type: none"> <li>▶ Charge battery (via charging gun).</li> <li>▶ Contact Eurabus-approved service.</li> </ul>
Vehicle does not start (24V)	Battery isolating switch turned off.	<ul style="list-style-type: none"> <li>▶ Switch on battery isolating switch (↪ 9.4.4, page 86).</li> </ul>
Coolant temperature too high	Low coolant level or cooling system not completely bled.	<ul style="list-style-type: none"> <li>▶ Replenish coolant and bleed system. (↪ 10.1.3, page 95).</li> </ul>
	Radiator heavily soiled on outside.	<ul style="list-style-type: none"> <li>▶ Clean radiator (see maintenance instructions).</li> </ul>
	Radiator fan broken	<ul style="list-style-type: none"> <li>▶ Contact Eurabus-approved service.</li> </ul>

#### Braking system

Malfunction	Possible cause	Recommended remedial action
Warning lamp lights up while vehicle is in motion.	Caution! Stop immediately. Little or no brake pressure. No pressure in air reservoir.	<ul style="list-style-type: none"> <li>▶ Contact Eurabus-approved service.</li> </ul>
Brakes have uneven braking effect.	Poor tyre quality.	<ul style="list-style-type: none"> <li>▶ Replace worn tyres.</li> </ul>
	Insufficient tyre pressure.	<ul style="list-style-type: none"> <li>▶ Check tyre pressure; adjust as necessary.</li> </ul>
Parking brake cannot be released.	Insufficient or no air reservoir pressure in parking brake circuit.	<ul style="list-style-type: none"> <li>▶ In emergency: Release spring actuators mechanically (↪ 9.2.1, page 78) or use emergency release device (↪ 6.4.5, page 42) to move vehicle out of danger zone.</li> </ul>

		<ul style="list-style-type: none"> <li>▶ Bring vehicle immediately but safely to a halt and chock wheels to prevent it from rolling away. Seek Eurabus-approved service centre.</li> </ul>
--	--	--

## Steering

Malfunction	Possible cause	Recommended remedial action
Power assisted steering vibrates when steering wheel is turned.	Air in hydraulic system due to lack of fluid.	<ul style="list-style-type: none"> <li>▶ Check system for leaks.</li> <li>▶ Replenish steering hydraulics fluid (🔧 <b>10.1.4, page 96</b>)</li> </ul>
Vehicle cannot be steered correctly when driving straight ahead.	Insufficient tyre pressure.	▶ Check tyre pressure; adjust as necessary.
	Steering knuckle dry.	Lubricate steering knuckle.
	Insufficient steering hydraulic oil in system.	<ul style="list-style-type: none"> <li>▶ Check system for leaks.</li> <li>▶ Replenish steering hydraulics fluid (🔧 <b>10.1.4, page 96</b>)</li> </ul>
Steering not smooth.	Air in hydraulic system. Insufficient steering hydraulic oil in system.	<ul style="list-style-type: none"> <li>▶ Check system for leaks.</li> <li>▶ Replenish steering hydraulics fluid (🔧 <b>10.1.4, page 96</b>)</li> </ul>

## Electrical (24V) system

Malfunction	Possible cause	Recommended remedial action
Battery charge lamp in driver's display lights up when engine is running.	DC/DC converter not working	▶ Seek EURABUS-approved service centre.

## Heating, ventilation, air conditioning (HVAC)

Malfunction	Possible cause	Recommended remedial action
Poor temperature control in heating mode.	Poor passenger compartment ventilation.	▶ Remove items of luggage or clothing from ventilation openings.
Insufficient or no output from air conditioning system.	Recirculated air filter mat soiled/contaminated.	▶ Clean recirculated air filter mat.
	Evaporator iced up.	▶ Open diffusers for passenger compartment ventilation.

## Doors

Malfunction	Possible cause	Recommended remedial action
Door does not close.	Emergency lever actuated.	▶ Make door ready for operation again (🔧 <b>6.4.1, page 39 and 6.4.2, page 39</b> ).
	Loss of air pressure	▶ Charge vehicle from external source (🔧 <b>9.2.2, page 79</b> ).
	Reversing system active.	▶ Remove obstacles from door entrance area.
Door does not open.	Door obstructed on outside by service flap or obstacle.	<ul style="list-style-type: none"> <li>▶ Close the service flap.</li> <li>▶ Remove obstacle.</li> </ul>

### 9.8.1.1 Authorised specialist personnel

Recommended remedial action, to be carried out only by properly trained personnel. If in doubt, have a Eurabus-approved service centre carry out the work.

## 10 Maintenance & Care

### 10.1 Information about environmental protection

#### 10.1.1 Information about environmental protection

##### Disposal of service fluids



##### Environmental note

###### Coolant

Dispose of antifreeze and mixtures of antifreeze and water in the correct manner as hazardous waste. Observe local authority regulations and read the product and safety data sheets provided by the respective manufacturer.

###### Hydraulic fluid

Dispose of used hydraulic fluid in the correct manner as hazardous waste. Observe local authority regulations and read the product and safety data sheets provided by the respective manufacturer.

###### Filter and drying agent cartridges

Filter elements, such as oil and fuel filters, drying agent elements from air dryers are hazardous waste products and must be disposed of in the correct manner. Observe local authority regulations and read the product and safety data sheets provided by the respective manufacturer.

###### Batteries (24V batteries)

Old batteries contain hazardous materials. They must be returned to the seller to be disposed of correctly or taken to a collection point. Never dispose of used batteries as domestic waste. Please also observe the relevant national regulations.

###### Batteries (high voltage traction batteries)

The high voltage traction battery can be returned to Eurabus at the end of its operational life, to maintain the correct recycling process.

###### Refrigerant

Disposal of refrigerants (e.g., R 407C) should only be undertaken by specialist companies which have the trained personnel and technical equipment to do this. On no account may refrigerant be released into the atmosphere. Have a EURABUS service centre dispose of refrigerants. Please also observe the relevant national regulations.

###### Cleaning and care products

Only use cleaning and care products that comply with the legislation governing washing and cleaning products and that are registered with the office for environmental protection.

Cleaning and care products must be composed of biologically degradable substances (detergents).

Collect residual quantities of cleaning and care products in their original packaging and take to a collection point. Observe local authority regulations and read the product and safety data sheets provided by the respective manufacturer.



---

Information about collection points can be obtained from any EURABUS service centre, from the seller or supplier of the service fluids or from the local authorities.

Cleaning and care products  **10.3.1, page 105.**

### 10.1.2 Service work to be undertaken





---







The operational reliability of the vehicle is essential for safe driving. Correct maintenance and care ensure operational reliability.

In addition to the preparations before each journey (  **8.2.1, page 55**), the following maintenance tasks and additional work must be carried out every week or every month:

#### Weekly maintenance work

- Check and replenish fluid level in windscreen washer system (  **10.1.5, page 97**).
- Check assemblies for leaks
- Check and rectify tyre inflation pressure (  **11.4.4, page 118**).
- Clean air recirculation filter mats in air conditioning system.
- (Every 2 weeks, or more often in extremely dusty conditions).
- Check condition of air suspension bellows (  **10.1.7, page 99**).

#### Monthly maintenance tasks

- Non-maintenance-free batteries: Check fluid level in batteries; top up fluid if necessary.
- Check condition of wiper blades; change if necessary(  **10.1.6, page 98**).
- Check setting of washer jets; correct if necessary (  **10.1.6, page 98**).
- Check coolant level; correct if necessary (  **10.1.3, page 95**).
- Check steering hydraulics fluid level; correct if necessary (  **10.1.4, page 96**).
- Check air filter system
- Check compressed air tanks for water accumulation(  **10.1.8, page 100**).
- Check brake pad/lining wear (  **page 10.1.9, page 101**).
- Inspect the side paintwork, wheel housings, engine, and engine components for corrosion.



---

All maintenance work is listed and explained on the following pages.

#### Additional work

Additional work, as described in the maintenance record, can be carried out at your own workshop provided that trained personnel and the appropriate tools are available.

### 10.1.3 Checking and replenishing coolant

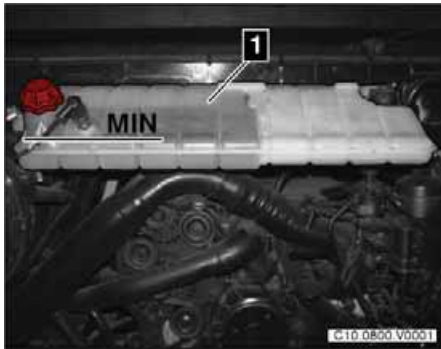

A message appears in the driver's display if the coolant level is too low.



#### Risk of accident

If the engine is started suddenly while work is being carried out in the engine compartment, serious injuries could be caused.

Take precautions to prevent the engine from being started inadvertently.

Attach a sign saying "Do not start engine" to the steering wheel.

#### Checking coolant level

- ▶ Park vehicle on hard, level standing.
- ▶ Switch off engine and withdraw ignition key.
- ▶ Open the engine compartment flap.
- ▶ Check coolant level on expansion tank **1**.

The coolant level should not be below the MIN mark on a cold engine. Replenish coolant as necessary.



#### Replenishing coolant



#### Risk of scalding

The cooling system is pressurised. If coolant sprays out it could cause severe scalding. Do not open the cap until the engine has cooled down.



Coolant is composed of water, antifreeze agent and corrosion inhibitor. Make sure that the mixing ratio is correct when topping up the coolant (  **11.5.1, page 119**).

Never top up with water without antifreeze, even if no antifreeze properties are required.

Do not top up with cold coolant in the case of severe coolant loss and resulting high operating temperatures. The engine could be damaged due to the high temperature difference.

- ▶ Park vehicle on hard, level standing.
- ▶ Switch off engine and withdraw ignition key.
- ▶ Allow engine to cool down.
- ▶ Open the engine compartment flap.
- ▶ Carefully open cap **2** of expansion tank and allow pressure to escape.
- ▶ Open cap fully and remove.
- ▶ Replenish with coolant up to MIN mark.
- ▶ Screw cap **2** back on.

The coolant level should not be below the MIN mark on a cold engine. Replenish coolant as necessary.



#### Environmental note

When filling, collect overflowing coolant in a suitable container.

Do not allow any coolant to contaminate the soil or bodies of water. The environment will otherwise be polluted.

### 10.1.4 Checking steering hydraulic fluid level

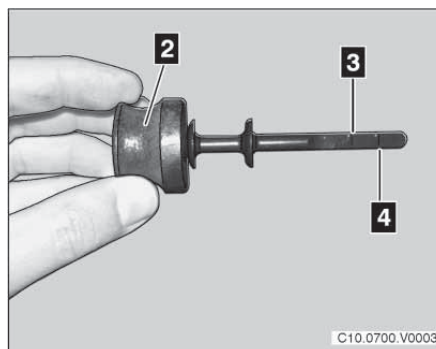

The fluid reservoir **1** for the steering hydraulics is accessible via the engine compartment flap.





## Risk of scalding

A low oil level may cause malfunctions or lead to complete failure of the steering system.

In the event of fluid loss, have the steering checked at a Eurabus-approved service centre without fail.

- ▶ Park vehicle on hard, level standing.
- ▶ Starting the engine.
- ▶ Open engine compartment flap (  **5.1.3, page 25**).
- ▶ Pull out dipstick **2**.
- ▶ Wipe off any oil with a cloth.
- ▶ Push in dipstick **2** again fully and pull out to measure level.

The oil level must be between the MAX mark **3** and the MIN mark **4**.



The oil level falls 1 to 2 centimetres when the engine is stationary.



Replenish hydraulic fluid (  maintenance instructions on **10, page 93**) or seek help from a Eurabus-approved service centre.

### 10.1.5 Replenishing fluid in windscreen washer system

The windscreen washer system can be found behind the foremost service flap on the left-hand side.



## Risk of fire

The concentrated windscreen washer fluid is inflammable. Therefore, avoid fire, smoking and naked flames when handling concentrated washer fluid.

- ▶ Open service flap (  **5.1.4, page 26**).
- ▶ Open cap of filler neck.
- ▶ Fill the reservoirs with a mixture of water and windscreen washer fluid concentrate.
- ▶ Close cap of filler neck.
- ▶ Close the service flap.
- ▶ Check operation of windscreen washer system.



Add windscreen washer antifreeze in winter. Adjust the mixing ratio to the outside temperature. Observe the specifications from the antifreeze manufacturer. Capacity of washer fluid reservoir  page xxx.

### 10.1.6 Changing wiper blades

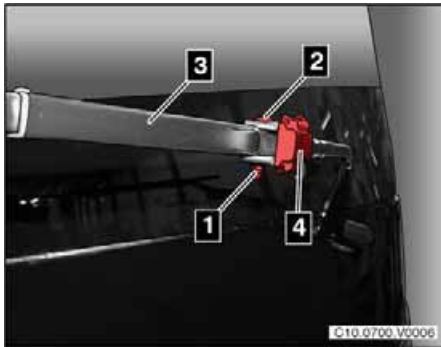

Wiper blades which are worn, torn or no longer wipe properly must be changed.



**Risk of injury**

The windscreen wipers could otherwise start to move and cause injury.

Remove the key from the ignition lock before changing the wiper blades.

- ▶ Fold out the wiper blade arm.
- ▶ Loosen hexagon nut **1**.
- ▶ Unscrew bolt **2** and remove wiper blade **3**. Fit in the reverse order.

#### Adjusting washer jets of windscreen wipers

The washer jets can be adjusted if washer fluid is not sprayed evenly over the whole wiping area. The washer jets are located on the wiper blade holders **4**.



**Risk of injury**

The windscreen wipers could otherwise start to move and cause injury.

Remove the key from the ignition lock before adjusting the spray nozzles.

- ▶ Adjust the washer jets using a suitable object (e.g., a needle).
- ▶ Check the spray nozzle setting. Repeat the adjustment process if necessary.

### 10.1.7 Checking condition of air suspension bellows

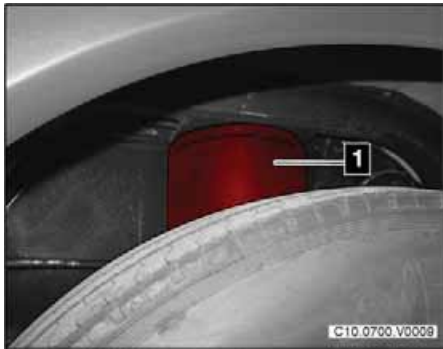

The air suspension bellows **1** are subject to an ageing process. The ECAS system will no longer operate properly if the air-suspension bellows are damaged or worn.



#### Risk of accident

The vehicle could start to move uncontrollably, and persons could become trapped.

Before releasing the spring-loaded cylinders, take precautions to prevent the vehicle from rolling away.

Apply the parking brake.

Place wheel chocks under the wheels.

- ▶ Take precautions to prevent the vehicle from rolling away.
- ▶ Visually inspect all air suspension bellows **1** at all axles for damage and signs of wear.



Damaged air suspension bellows should be renewed without delay at a EURABUS-approved service centre.

### 10.1.8 Checking compressed air tanks for water accumulation

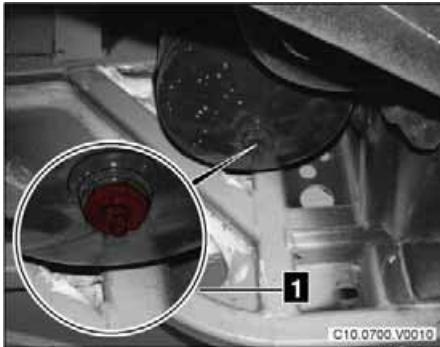

The accumulated condensate is drained through the water drain valves of the compressed air tanks.



#### Risk of accident and injury

If the air dryer is not functioning, the compressed air braking system could freeze during the winter period. You should therefore regularly drain off any condensation water that has accumulated.

Water spraying out can cause eye injuries.

Always wear protective goggles and keep at a safe distance from the valve.

The vehicle could start to move uncontrollably, and persons could become trapped.

Before releasing the spring-loaded cylinders, take precautions to prevent the vehicle from rolling away.

Apply the parking brake.

Place wheel chocks under the wheels.

#### On compressed air tank

The compressed air tank can be found on the left and right of the front axle and is accessible from underneath.

- ▶ Raise vehicle or drive over a pit.
- ▶ Take precautions to prevent the vehicle from rolling away.
- ▶ Carefully press in pin **1** of water drain valve.

Condensate escapes from the water drain valve. Keep pin pressed in until no more condensates come out.



If large amounts of condensate are drained off, have the air dryer checked at a EURABUS-approved service centre.

### 10.1.9 Checking brake pad/lining wear

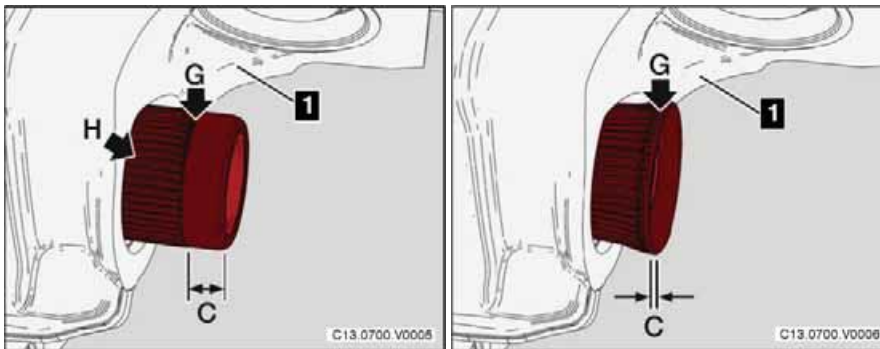

Brake pad/lining wear is checked electronically. An appropriate symbol appears in the driver's display if the brake pads/linings are worn below the minimum value.



The brake pad/lining wear symbol appears in the driver's display if the brake linings are worn below the minimum thickness. Have the brake system checked at a EURABUS service centre.

Also check brake pad/lining wear at all brake callipers once a month. The wheels do not need to be removed to do this.

#### Checking brake pad/lining wear at brake calliper - version 1



#### Risk of accident

When the wear limit has been reached, the brake linings and the brake discs must be checked or replaced at a EURABUS-approved service centre.

Worn brake pads are a high safety risk.

The wear indicator can be found on the brake calliper **1**.

- ▶ If necessary, remove protective cap of wear indicator.
- ▶ Check *dimension C*.

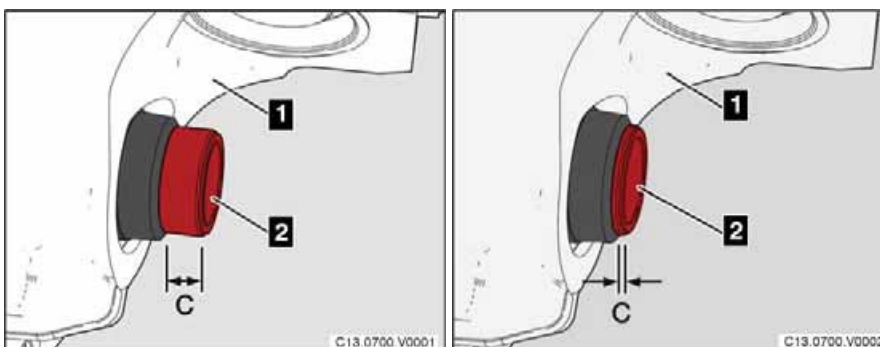

If *dimension C*  $\leq 1$  mm, brake pad/lining thickness and the brake disc must be checked with the wheel removed. If the minimum dimensions for the brake disc and the brake pad/lining are below the permitted amount, the respective components must be renewed on both sides of the axle.

### Checking brake pad/lining wear at brake calliper - version 2



#### Risk of accident

When the wear limit has been reached, the brake linings and the brake discs must be checked or replaced at a EURABUS-approved service centre. Worn brake pads are a high safety risk.

The wear indicator can be found on the brake calliper **1**.

- ▶ If necessary, remove protective cap of wear indicator.
- ▶ Check *dimension C* between brake calliper **1** and guide sleeve **2**.

If *dimension C*  $\leq 1$  mm, brake pad/lining thickness and the brake disc must be checked with the wheel removed. If the minimum dimensions for the brake disc and the brake pad/ lining are below the permitted amount, the respective components must be renewed on both sides of the axle.

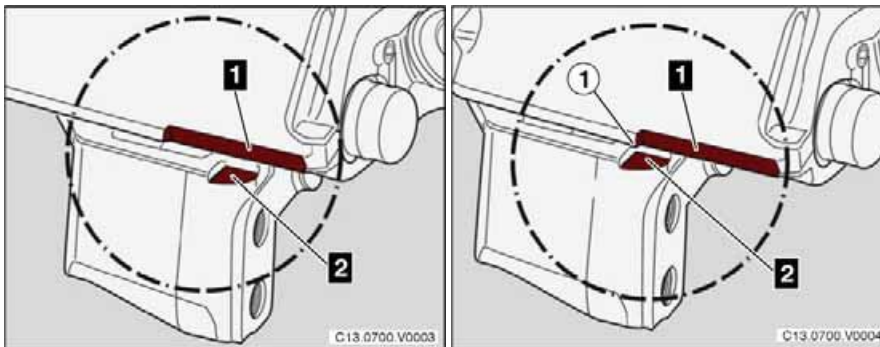

### Checking brake pad/lining wear at brake calliper - version 3



#### Risk of accident

When the wear limit has been reached, the brake linings and the brake discs must be checked or replaced at a EURABUS-approved service centre. Worn brake pads are a high safety risk.

Mark **1** on the brake calliper and mark **2** on the brake carrier indicate the brake pad/lining wear.

- ▶ Check *markings 1* and *2*.

If position **1** is reached, the brake pad/lining thickness and the brake disc must be checked with the wheels removed.

If the minimum dimensions for the brake disc and the brake pad/lining are below the permitted amount, the respective components must be renewed on both sides of the axle.

## 10.2 Decommissioning / recommissioning

### 10.2.1 Demobilising vehicle



#### Environmental note

All operating fluids and cleaning agents damage the environment if disposed of incorrectly.

Only clean the vehicle at washing facilities intended for this purpose.

Dispose of service fluids in accordance with the regulations (  **4.2.4, page 21**).

The following work must be carried out if the vehicle is to be taken off the road for longer than 6 months. Not all the work listed below will need to be carried out if the vehicle is to remain unused for a shorter period. Any Eurabus-approved service centre can provide information on this.

- ▶ Check the vehicle underbody carefully before cleaning.

Oil stains may be an indication of damaged components. It is essential to repair damaged components before taking the vehicle out of service.

- ▶ Clean vehicle undercarriage.
- ▶ Repair damaged parts of the underbody using under seal.
- ▶ Clean the vehicle thoroughly inside and out.
- ▶ Drain the oil from the transmission and rear axle. Fill with fresh oil of the appropriate grade. Check the oil level.
- ▶ Empty all fresh water and wastewater tanks.
- ▶ Replenish windscreen washer reservoir.
- ▶ Drain condensation water from the air reservoirs.
- ▶ Remove the filter cartridge from the air filter. Spray anticorrosion oil on the upper and lower parts of the filter housing.
- ▶ Remove any corrosion from bare surfaces on the assemblies as well as linkages, levers, lines, etc., and spray with anti-corrosion oil.
- ▶ Seal all openings airtight, for example on the air filter, oil dipstick, vent openings on the assemblies and the exhaust pipe. The only exception to this is the fuel tank breather.
- ▶ Spray the seals of doors and hatches with silicone spray.
- ▶ Treat the door locks on the outside of the vehicle with graphite.
- ▶ Park the vehicle in a well-ventilated dry building if possible. Large fluctuations in temperature can use condensation.
- ▶ Leave the windows open slightly to allow air to circulate.
- ▶ Open flaps in passenger compartment.
- ▶ Place air dehumidifiers in the vehicle interior and empty at regular intervals.
- ▶ Disconnect and remove the 24V batteries.
- ▶ Fold up or remove the windscreen wipers.
- ▶ If possible, relieve the tyres and wheels of load by supporting the vehicle on stands. The wheels must not be lifted off the floor.
- ▶ Use wheel chocks if the vehicle is not supported on stands.
- ▶ Release parking brake.
- ▶ Increase the tyre pressure by 0.5 to 1.5 bar above normal pressure.
- ▶ Protect the tyres from direct sunlight and humidity; cover them if necessary.



---

Do not allow the tyres to come into contact with chemical substances such as oil, paint, or fuel. The tyres could otherwise be damaged.



---

Attach a warning notice to the steering wheel with the following text:

- "No air reservoir pressure - spring-loaded cylinders not working."

### 10.2.2 Re-commissioning vehicle

If the vehicle has been parked up for more than 6 months and work was carried out as described (  **10.2.1, page 103**), take the following action to bring the vehicle back into service:

- ▶ Remove the tyre covers and inflate the tyres to the specified pressure.
- ▶ Lower the vehicle from the stands. Remove the wheel chocks.
- ▶ Check the oil level in the steering hydraulic system; top up if necessary.
- ▶ Remove the covers from the air filter.
- ▶ Insert a filter cartridge into the air filter housing.
- ▶ Install and connect the 24V batteries. Check the vehicle electrical system.
- ▶ Fold down or reattach the windscreen wipers.
- ▶ Check all pipes, hoses and connections for leaks and cracks.
- ▶ Test the braking system. Carry out a road test.



---

Tyres are affected by a natural ageing process. Before using the vehicle again, it is essential to inspect the tyres for brittleness and cracks.



## 10.3 Cleaning and care

### 10.3.1 Cleaning and care of vehicle

Regular cleaning and care of the vehicle increases its service life and retains its value. Therefore, observe the following instructions.



#### Risk of injury

Cleaning agents cause irritation to the skin and airways.

Wear gloves and cover your body.

Make sure that there is sufficient ventilation.



#### Risk of poisoning

Diesel, regular and premium grade fuels are harmful to your health. They should not be used as cleaning agents.

Always keep care products and cleaning agents in sealed containers and out of the reach of children.

Observe the instructions for use supplied with the care products and cleaning agents.



Carry out maintenance and care of the paintwork, corrosion protection and any retreatment procedures in a cycle as per the latest EURABUS service information.



#### Environmental note

Only car wash products may be used which comply with the law on cleaning agents and are registered with the relevant authorities charged with environmental protection. They must be composed of biologically degradable substances (detergents).

Wastewater regulations and environmental protection requirements must be observed.

Vehicles should only be washed at appropriately equipped washing facilities.

Dispose of empty containers, cleaning cloths and polishing wads in an environmentally compatible manner.



---

During winter, the vehicle must be washed every day. Dirt binds with the road salt and causes corrosion, especially on the sensitive aluminium rims. Observe legal requirements and regulations of individual countries!

### Care of rims

The rim shoulders show signs of corrosion over time. Corrosion is frequently the cause of rim damage.

#### *When changing tyres*

- ▶ Check the rim shoulders for corrosion damage.
- ▶ If necessary, remove corrosion and coat steel rims with a corrosion-resistant rim paint.

### Cleaning exterior lighting of vehicle



#### Risk of accident

Only clean vehicle exterior lights provide the optimum light output.

Scratches and cracks in the plastic covers of the exterior lights interfere with optical properties, degrade the light, and frequently lead to increased glare.

Check the covers for defects and have them replaced at a Eurabus-approved service centre.



---

Do not use scouring agents or solvents (e.g., fuels, thinners, etc.) to clean the plastic lens of the exterior lights. Hard objects such as spatulas, ice scrapers, hard brushes or scouring pads should never be used. They will scratch the surface coating immediately.

- ▶ Loosen dirt, insect residue and salt with water and then rinse.



---

Car shampoo or rinsing solution and a soft sponge help to get rid of stubborn bits. A moistened paper towel can also be used.

### Cleaning windscreen wiper blades and wiper rubbers

Insects, dust, silicone, or waxy residue stick to the windscreen and wiper rubbers and damage the windscreen wipers. This causes tears in the wiper lips which will then leave smears on the windscreen as they wipe.



Never use windscreen wipers on a dry windscreen or to scrape off ice. This will quickly damage the wiper rubbers. Wipe off the windscreen wiper blades each time the vehicle has been washed. Dirt on the wiper blades does not just impair the wiping performance but can also quickly scratch the vehicle's windscreen. In the case of persistent smearing, change the wiper blades.

- ▶ Clean the windscreen with water and a commercially available glass cleaner.
- ▶ Clean the wiper blades and rubbers with water, a commercially available glass cleaner and a soft sponge.
- ▶ Regularly check that the wiper linkages and windscreen wiper system for ease of movement. Heavy fouling and corrosion results in equal application pressure on the windscreen being lost.



Changing windscreen wiper blades  **10.1.6, page 98.**

### Care of painted surfaces



#### Risk of injury

Accidents due to slipping may cause severe injuries.

Keep floors, ladders, and steps free from oil and grease.

Make sure that the ladder is secure.

There is a high risk of injury when working high above ground level.

Take precautions to prevent falls.



New paintwork is not fully hardened during the first weeks. Therefore, do not wash the vehicle in an automatic washing system or using steam jet and high-pressure cleaners for the first 2 months. Wash down the vehicle thoroughly from top to bottom. Bird droppings, tree resin, oil, grease, and dead insects will attack the paint if they are not washed off promptly.

### Prewashing

Before washing in an automatic washing system:

- ▶ Close all doors, windows, flaps, sliding roofs and roof hatches.
- ▶ Remove any attached parts (e.g., satellite receiver on the roof) before washing the vehicle.
- ▶ Soften dusty and sandy dirt on the vehicle surfaces with large amounts of water. Then remove with a high-pressure cleaner (  **page 106**) without additional brushing.

## Condition of washing brushes

The washing brushes of the vehicle washing system must be checked and cleaned to remove any dirt every day or every week, depending on the number of washing cycles run per day. Remove tar and bitumen immediately using an appropriate cleaning agent.

## Prewash and main wash



---

Washing systems with rotating brushes should only be used after the vehicle has been sprayed down. Before driving into the washing system, make sure that the exterior mirrors are folded in or removed. If this is not possible, the exterior mirrors must be detached otherwise there is a risk of damaging the exterior mirrors and their attachment.

Do not use acidic or alkaline cleaning agents. Switch off the air conditioning system before entering the washing system. The washing brushes could otherwise be sucked into the roof-mounted air conditioning fans and cause damage. Water could also find its way into the vehicle.

Switch off engine before washing the vehicle. Water could otherwise be sucked in and cause damage to the engine.

If the vehicle is washed in an automatic washing system, ensure that:

- The washing system is large enough for the vehicle.
- The rotating brushes are soaking wet before the wash cycle starts.
- Large volumes of water must be supplied during the wash to avoid dirt from sticking to the washing brushes. Otherwise, they will scratch the paintwork.
- The contact pressure of the brushes is not too great.
- Only the ends of the brush bristles do the actual cleaning.
- The paintwork could otherwise be damaged.
- For the prewash, use phosphate-free cleaning agents which are gentle on the paintwork and approved by EURABUS.
- The main wash is performed with a foam that is gentle on the paintwork.
- Finally, the whole vehicle must be rinsed with large volumes of clean water.



---

If you use rainwater or if you mix rainwater and fresh water, observe the dosing instructions from the cleaning agent manufacturer to avoid overdosing of cleaning additives. Constant overdosing will damage the paintwork.

An up-to-date product list is available from the EURABUS customer service department.

It is recommended to use fresh water for the final rinse and wax sealing cycle if no water treatment system is available.

## Cleaning with high pressure cleaners



### Risk of scalding and injury

Risk of injury caused by high pressure and hot water. Do not point the high-pressure jet at people.

Improper use of the high-pressure cleaner and the use of damaged accessories can result in injury.

Refer to the operating instructions for the high-pressure cleaner.

Adhere to safety information and wear suitable protective clothing.



### Risk of accident

Do not aim the high-pressure jet directly at a single point on tyres for a long period of time. The tyres could be damaged and blow out on long motorway journeys.

Replace damaged tyres immediately.



Technical data:

- MAX permissible water pressure: 60 bar
- MAX permissible water temperature: 60 °C



Also observe the specifications issued by the high-pressure cleaner manufacturer.



Do not use high pressure cleaners with round jet nozzles and "power nozzles". Only use high pressure cleaners with flat jet nozzles. Tyres and seals could otherwise be damaged. Replace damaged tyres.

Do not wash the engine with high pressure cleaners. Electrical components, such as the engine control unit, could be damaged by penetrating water.

Do not direct the water jet too close to the engine intake. This could cause engine damage.

Do not point the water jet directly at window and door gaps, locks and seals or suspension systems and propeller shafts. Components can be damaged.

- ▶ Maintain a minimum distance of about 30 centimetres between the high-pressure cleaner and the surface which you are cleaning.
- ▶ Keep the water jet moving while you are cleaning.

## Wax sealing



### Risk of accident

Wax on the windscreen and side windows causes light refraction which could irritate the driver.

Clean the windows with silicone cleaner after applying wax preserver.

Take the following action after each wash:

- ▶ Apply a wax preserver including a polishing agent.
- ▶ Apply hot wax preserver after every third to fifth wash.

This coats the paintwork with regreasing substances to prevent dirt from sticking to it, thereby making washing easier.

### **Underbody protection**

Check underbody protection before and after the winter season; if necessary, have it repaired or renewed at a EURABUS-approved service centre.

As an underbody sealant, EURABUS recommends TECTYL 5624W or a different product with the same specifications.

### **Cavity sealant**

Have the cavity sealant renewed every 4 years at a EURABUS-approved service centre.

As a cavity sealant, EURABUS recommends MAKRA cavity sealant HK 400 or a different product with the same specifications.

## Polishing paintwork

If the paint becomes dull due to worn brushes or washing agent overdoses, polish the paint to make it more resistant again to the weather and environmental influences.



Only use products approved by EURABUS for polishing paintwork. An up-to-date product list is available from the EURABUS customer service department.

Do not polish in the sun - the polishing paste will dry out too quickly. It is advisable to work on one small area at a time to prevent the polishing paste from drying out.

## Seals on doors and covers

Seals are exposed to extreme weather influences and must be cleaned and treated with care products at regular intervals.

- ▶ Wipe the seals clean with a damp cloth.
- ▶ Spray the seals with silicone spray.

## Door locks

- ▶ Treat the door locks on the outside of the vehicle with graphite.
- ▶ During the winter months, use a door lock de-icer.

## Cleaning vehicle interior

### *Leatherette*

Only clean the leatherette with a simple soap solution and a soft damp cloth.



To remove tough stains, never use aggressive cleaning agents. These are corrosive against the paint of the leatherette. The leatherette would become hard and brittle. Only remove tough stains using ethanol (alcohol). Observe the safety instructions on the ethanol container.

Only remove tough stains using ethanol (alcohol).

### *Plastic surfaces*

Plastic surfaces are cleaned with warm water (up to 50 °C) and a soft cloth. All common household cleaners can be used diluted in water up to approx. 2 %. For tougher jobs, white spirit can be used briefly.



Never use scouring products or chemicals commonly used in the household, like stain remover, iodine tincture, nail varnish remover, acetone, petroleum ether, etc. This could act aggressively against the plastic surface and cause damage.

### *Seat belts*



#### **Risk of injury**

Belt straps are overstretched if subjected to extreme loads, e.g., in the case of accidents or improper use. Overstretched belt straps can no longer perform their safety-related task properly.

Replace seat belts and belt buckles that have been damaged or heavily strained during an accident.



Chemical cleaning agents destroy the safety properties of the seat belts. Do not bleach or dye the belts.

- ▶ Only clean belt straps using soap and water.
- ▶ Check that the belt retractor mechanism functions smoothly.
- ▶ Inspect the belt straps for the following external damage:
  - Tears
  - Fraying

- Burn marks

### ***Seat and backrest padding***

Dirt can block the pores of the PU foam in the seat and backrest padding and thereby reduce the cushioning effect.

- ▶ Vacuum clean or brush the dust off the padding regularly. If necessary, use a commercially available vacuum cleaner with brush attachment.



---

The seat padding, particularly on the driver's seat, should be replaced every 500.000 km as the cushioning properties will have been lost. Information about this can be obtained from EURABUS.

### ***Seat covers – Textile***

Stains can be best removed when they are still fresh and have not penetrated the fibres.



---

To remove tough stains, never use aggressive cleaning agents. These could damage the cover beyond repair.

- ▶ Fresh stains should be removed using a dry, foam-like cloth with good absorbing properties.
- ▶ Dried on stains can be loosened by patting or brushing and then removed with a slightly damp cloth.
- Use a warm soapy solution.
- The soiled area should never be rubbed down vigorously.
- Always wipe from the outside of the stain inwards.
- Never soak the material.
- Always air dry the material.
- Do not use a heat source to dry.

### ***Seat covers – Leather***

Leather is a living material that becomes richer as it ages, providing it receives the right care.

- ▶ Never subject leather covers to direct sunlight.
- ▶ A heater should never be placed closer than 20 - 30 cm to the leather cover.
- ▶ Clean leather covers regularly with a vacuum cleaner and soft brush attachment.



---

To remove tough stains, never use aggressive cleaning agents. These could damage the cover beyond repair.

- ▶ For cleaning and care of leather covers, use special leather care products.



---

#### Removing chewing gum:

Place a bag filled with ice cubes on the affected area to chill it. When the chewing gum becomes hard, it will be removable. If there is any residue, heat up the affected area with a hairdryer from a sufficient distance and remove the residue with adhesive tape.

#### Removing greasy/oily stains:



Remove/absorb the grease/oil with a dry piece of cloth. The remaining grease/oil will eventually be absorbed by the leather.

#### ***Fabrics and carpets***

- ▶ Brush or vacuum upholstery and fabrics in the direction of the nap or clean them with warm soapy water.
- ▶ Use a dry foam cleaner on stubborn stains.
- ▶ Completely dry upholstery and fabrics before they are used again.



---

Do not use vacuum nozzles made of rubber or rubber attachments. Fibres could be torn out of the upholstery.



---

Also observe the specifications issued by the high-pressure cleaner manufacturer.

#### **Cleaning driver's display**

The driver's display is equipped with modern, maintenance free technology. Preventive maintenance work is therefore not required.



---

Never use solvents such as thinners or petrol. Do not use abrasive cleaning agents as they could damage the system components.  
Plastic instruments can be scratched if they are rubbed too hard. It may then no longer be possible to read the instruments correctly.

#### ***Slight soiling***

- ▶ Wipe down the system components with a damp cloth.

#### ***Heavier soiling***

- ▶ Use cleaning agents or care products specifically intended for plastics.

#### **Cleaning strip lights**



---

Never use cleaners that contain softening agents. Soaps, washing-up liquids, alcohol-based cleaners or similar substances attack the surfaces.

- ▶ Clean the lighting strips using a damp cloth and clear water.

#### **Cleaning insulating materials in engine compartment**



To preserve the fire protection in the engine compartment, do not use any organic cleaning agents such as thinners or chlorine-based cold cleaners to remove dirt from insulating materials.

Cleaning agents ingrained in insulating materials may cause a potential fire risk. The insulation will lose its thermal insulation properties immediately.

- ▶ Wash off dirt by hand with clean water and a brush. Do not use high pressure cleaners.
- ▶ If necessary, remove, clean, and then refit the engine encapsulation.

Replace damaged insulating parts if fouling was caused by painting or maintenance work (paint spray and grease residue, penetrating fuel, and operating fluids).

## **i**

---

The high thermal loads and high degree of fouling in the engine compartment cause all insulating materials to lose their original thermal and acoustic insulating properties after 2 to 3 years, depending on the operating conditions and the region where the vehicle is operated.

## 11 TECHNICAL DATA

### 11.1 Data plates

#### 11.1.1 Vehicle and component type plates



All important information about the vehicle is given on the engine data card and the vehicle and component type plates.



---

This data is required when ordering replacement parts and if there are any questions concerning technical issues. Always have this information to hand when you contact us with queries.

#### **Vehicle identification number**

The plate with the vehicle identification number **1** and details concerning the total weight and axle loads are in the front entrance area.

#### **Chassis number**

The chassis number **2** is stamped in the front right-hand wheel housing.



---

See also the operating instructions from the traction motor manufacturer.

## 11.2 Dimensions, weights, loads

### 11.2.1 Vehicle dimensions

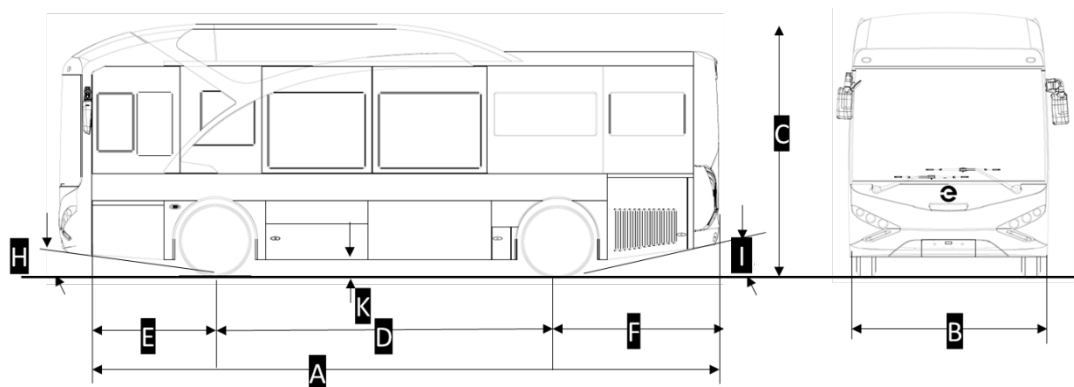

<b>Total length</b>	<b>A</b>	8540mm
<b>Total width <sup>1</sup></b>	<b>B</b>	2450mm
<b>Total height</b>	<b>C</b>	3260mm
<b>Wheelbase</b>	<b>D</b>	4430mm
<b>Overhang, front</b>	<b>E</b>	2020mm
<b>Overhang, rear</b>	<b>F</b>	2090mm
<b>Front overhang angle</b>	<b>H</b>	9°
<b>Rear overhang angle</b>	<b>I</b>	12°
<b>Ground clearance</b>	<b>K</b>	190mm

<sup>1</sup> Without exterior mirrors

### 11.2.2 Turning circles

<b>Minimum theoretical turning circle</b>	15m
---	-----

## 11.3 Engine

### 11.3.1 Basic traction motor data

<b>power output (continuous/peak)</b>	145/200kW
<b>max speed</b>	2700 rpm
<b>torque (continuous/peak)</b>	1100/2450Nm



---

Refer to the vehicle registration document for information on vehicle noise levels.

## 11.4 Wheels and tyres

### 11.4.1 Torque settings for wheel nuts

<b>Rim type</b>	<b>Hub centring</b>
Steel rim	575 ± 25Nm



- 
- Check the wheel nuts regularly to ensure that they are correctly seated. Retighten the nuts if necessary.
  - It is essential to retighten the wheel nuts of a changed wheel after approximately 50 km.
  - With new or newly painted rims, the wheel nuts must also be retightened after approx. 1000 to 4000 km.
  - Always tighten the wheel nuts in a crosswise sequence.

### 11.4.2 Tyres and rim sizes

The tyres on the vehicle must match the size, speed index and load index specified in the vehicle registration certificate.

<b>Front axle</b>	255 / 70 R22.5
<b>Drive axle</b>	255 / 70 R22.5



---

See also the vehicle registration certificate.

### 11.4.3 Speed index

The speed index is part of the tyre designation. It specifies the permitted tyre speed range, e.g., 315/60 R 22.5 152/148 L.

Speed symbol	Speed
J	up to 100 km/h
K	up to 110 km/h
L	up to 120 km/h
M	up to 130 km/h

### 11.4.4 Tyre pressures

Front axle	8.0 bar
Drive axle	8.0 bar



---

Check the tyre pressures before starting a journey, i.e., when the tyres are cold. The specified tyre pressures are for road speeds above 60 km/h.

When checking the tyre pressure in enclosed spaces, please note that the tyre pressure increases or decreases by 0.2 bar for every 10 °C rise or drop in ambient temperature.

## 11.5 Capacities and service fluids

### 11.5.1 Coolant mixing ratios

Outside air temperature down to	Antifreeze	Water
minus 27 °C	40 vol. %	60 vol. %
minus 31 °C	45 vol. %	55 vol. %
minus 37 °C	50 vol. %	50 vol. %



Antifreeze must remain in the cooling system all year round to provide protection against corrosion and low temperatures and to increase the boiling point. The coolant must be replaced regularly as its capacity to provide protection against corrosion decreases with time. When topping up, make sure that the radiator antifreeze is correct.



When topping up (e.g., after coolant loss), an antifreeze volume component of 50 % in the coolant must be ensured. Heat dissipation deteriorates if the volume component exceeds 55 vol. %.



For details about replenishing antifreeze and replacement intervals, see maintenance record.

### 11.5.2 Windscreen washer reservoir



**Risk of fire**

The concentrated windscreen washer fluid is inflammable.

Therefore, avoid fire, smoking and naked flames when handling concentrated washer fluid.

The washer reservoir has a capacity of approx. 12 litres. Topping up the windscreen washer system  
👉 **10.1.5 page 97.**

## 11.6 Speeds

### 11.6.1 Speed limitation

All vehicle models are equipped with a speed limiter which restricts the maximum speed to 100 km/h.

## 11.7 Number of seats and doors

### 11.7.1 Seats



#### Risk of injury

Standing on the passenger seats is not permitted. Passengers could injure themselves while the vehicle is in motion, e.g., from sudden braking.

### 11.7.2 Number of doors

Number of doors	2
-----------------	---

## 11.8 Other

### 11.8.1 Electrical system

#### On-board voltage

The on-board electrical voltage is 24 volts for the control system and 600V for the traction system.

#### Batteries

2 x 12 V / 105 Ah

#### DC/DC converter

3000W

### 11.8.2 Climatic environmental conditions

All vehicle models can be operated at an ambient temperature range between +5 °C and +50 °C.



## 12 INDICES

### 12.1 Abbreviations

A	Ampere
Ah	Ampere hours
ABS	Anti-lock braking system
ASR	Acceleration slip/skid regulation
BAS	Brake assist system
BMS	Battery Management System
i.e. (id est)	That is
°C	Celsius
ca.	Approximately
CL	Clock
cm	Centimetres
cm <sup>3</sup>	Cubic centimetres
DOT	Department of Transportation
DTCO	Digital Tachograph
DVD	Digital Video Disc
EBS	Electronic braking system
ECAS	Electronically controlled air suspension
ECU	Electronic control unit
EHLA	Electro-hydraulic steering system
EOL	End of line
ESP	Electronic stability program
Poss	Possible
h	Hour
HVAC	Heating, ventilation, and air conditioning
FSB	Frequent-stop brake
Veh.	Vehicle
kg	Kilogram
km	Kilometre
km/h	Kilometres per hour
kW	Kilowatt
LED	Light emitting diode
m	Meter
MAX	Maximum
MIL	Malfunction indicator lamp
min.	Minutes
MIN	Minimum
ml	Millilitre
mm	Millimetre
MUX	Multiplexer
TA	Trailing axle
Nm	Newton meter
OBD	Onboard diagnosis
OBDI	Onboard diagnosis I (first development stage)
OBDII	Onboard diagnosis II (second development stage)
PRIO	Priority
RGB	Red / green / blue
SAE	Society of Automotive Engineers
SMUX	Switch multiplexer

SPN	Suspect parameter number (fault location)
StG	Control unit
WAF	Width across flats
DA	Drive axle
TEPS	Twin electric platform system
rpm	Revolutions per minute
etc.	Etcetera
V	Volt
FA	Front axle
VIN	Vehicle identification number
Vol.%	Percent by volume
W	Watt
e.g. (exempli gratia)	for example
ZBR	Central on-board computer
zul.	permissible
>	Greater than
<	Less than
	See
*	Optional equipment, special edition

## 12.2 Glossary

**ABS** (anti-lock braking system) prevents the wheels from locking when the vehicle is braked. This occurs independently of the structure of the road, thus maintaining vehicle steerability in critical situations.

**ASR** (acceleration slip regulation) prevents one or more wheels from spinning by braking them. This allows improved pulling-away on roads which are slippery on one side.

**BAS** (brake assist system) is an electronic control unit for boosting the brake force in emergency situations by automatically generating maximum brake pressure. The brake assist system becomes active when the service brake pedal is depressed very quickly, or the vehicle speed drops very suddenly. The advantage of the brake assist system is the shorter braking distance.

**EBS** increases road safety by shortening the stopping distance and offers improved vehicle stability during braking manoeuvres. Extensive monitoring functions as well as the display of brake pad wear offer an effective servicing system.

**ECAS** is an electronically controlled air suspension system which, as a system, includes several functions. Examples of these include increased ride comfort, constant vehicle height independent of payload, and lowering of the vehicle.

**EHLA** (electrohydraulic steering system) offers the advantages of an even smaller turning circle, active steering even when reversing, and various preset options (e.g., in the case of narrow bus stop bays) compared with conventionally steered trailing axles.

**ESP** (electronic stability program) is an active safety system for improving driving safety and driving stability. It makes a significant contribution to preventing the vehicle from skidding in corners or when avoiding obstacles. The brake force at each wheel is controlled individually in critical driving situations. The engine power output is reduced at the same time.

**FSB** (frequent-stop brake) operates with the same service brake circuit as the service brake but at a lower pressure. It can be applied manually or is activated automatically when a door is opened.

**MUX** (multiplexer) is an electronic switch which receives, processes, and transmits signals from, for example, buttons or control units. The CAN is used for transmitting the signals. See also CAN.

**Emergency lever** permits a door to be opened if there is risk of it becoming depressurised, thus allowing people to exit the vehicle.

**On-board diagnosis** monitors whether the engine is within the prescribed emission values, and store's fault messages internally.

**Retarder** operates the traction motor as generator to slow-down the vehicle and recharge the traction battery. With these additional brakes, the vehicle can be decelerated without increments and almost free of wear.

**Reversing system** prevents people and objects from being trapped when the hinged doors are opened or closed.