



SPECIFICATIONS

Puissance	4W vers le sol + 2,5W vers le haut
Flux à 3000°K-IRC70	300 lm + 100 lm
Configuration	Suspension
Température de couleur au choix	2200°K-2700°K-3000°K-4000°K-5000°K
IRC	90
Angle d'éclairage	15° + 100°
Alimentation	24VDC
Pilotage au choix	ON/OFF-DALI-DMX
Protection	IP65
Matériaux	Aluminium-Polycarbonate
Finition	Anodisation imitation laiton
Poids	4kg



PHOTOMETRIES

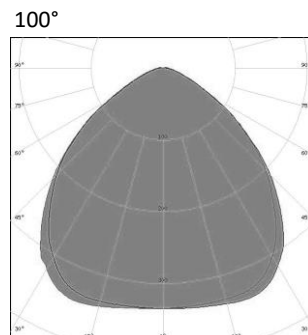
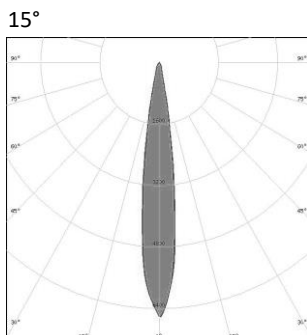



DETAILS TECHNIQUES

