

RD2 Primary & Secondary Rotary Drive

Primary rotation with secondary linear movement 12mm and 24mm versions. The RD2 and RD224 ranges are low backlash, high precision drives providing continuous primary rotation and secondary linear axis movement.



Product Overview

- Low backlash
- Continuous rotation to 500rpm
- 70mm OD flange
- Graduated handwheel with Vernier scale
- Axial Load: rotary shaft 40N
- Linear shaft movements of 12 and 24mm
- Long life bellows
- Bakeable to 230°C (motors removed)
- Stepper motor kits
- Encoder options

The RD2 uses the same primary axis movement as the RD1 and has the full RD1 options of extended shafts and motorisation. In addition, the RD2 is fitted with a high resolution actuator to give 12mm linear movement. This operates the azimuthal (R2) or tilt R3) movements of most standard VACGEN sample holders. The standard linear resolution is 0.02mm, but angular graduations can be supplied. The secondary axis can be motorised to give 0.05 microns resolution in half step mode. Adjustable microswitches are included with the R2 motor kit.

RD2 manual primary and secondary rotary drive

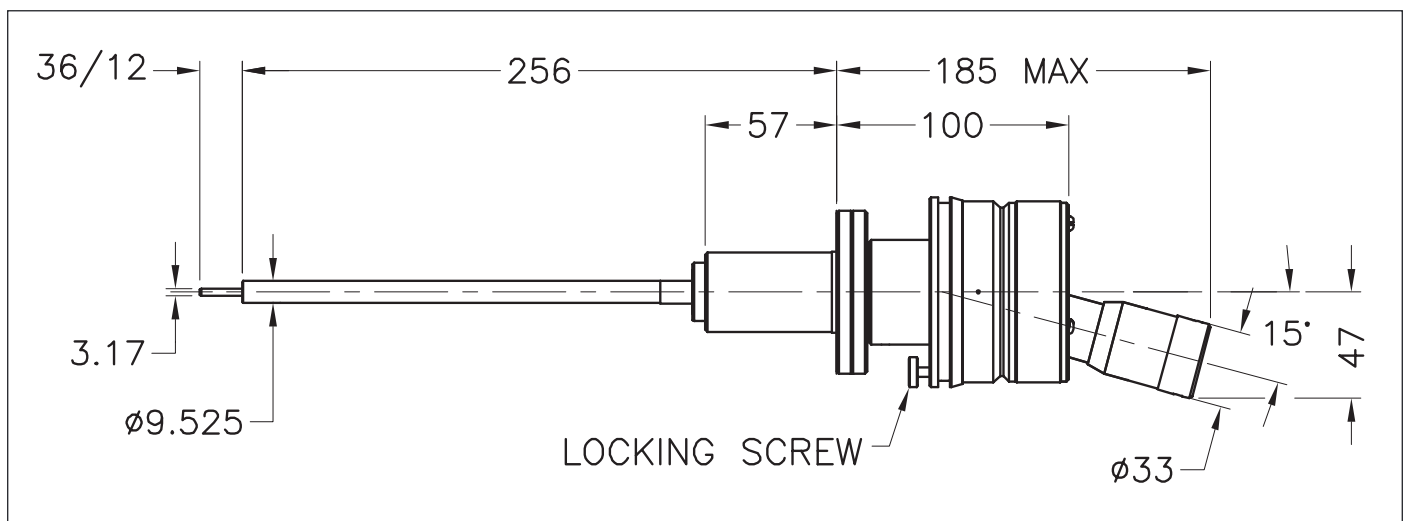

RD2 Primary & Secondary Rotary Drive

RD2 with both primary and secondary drive axis fitted with stepper motors

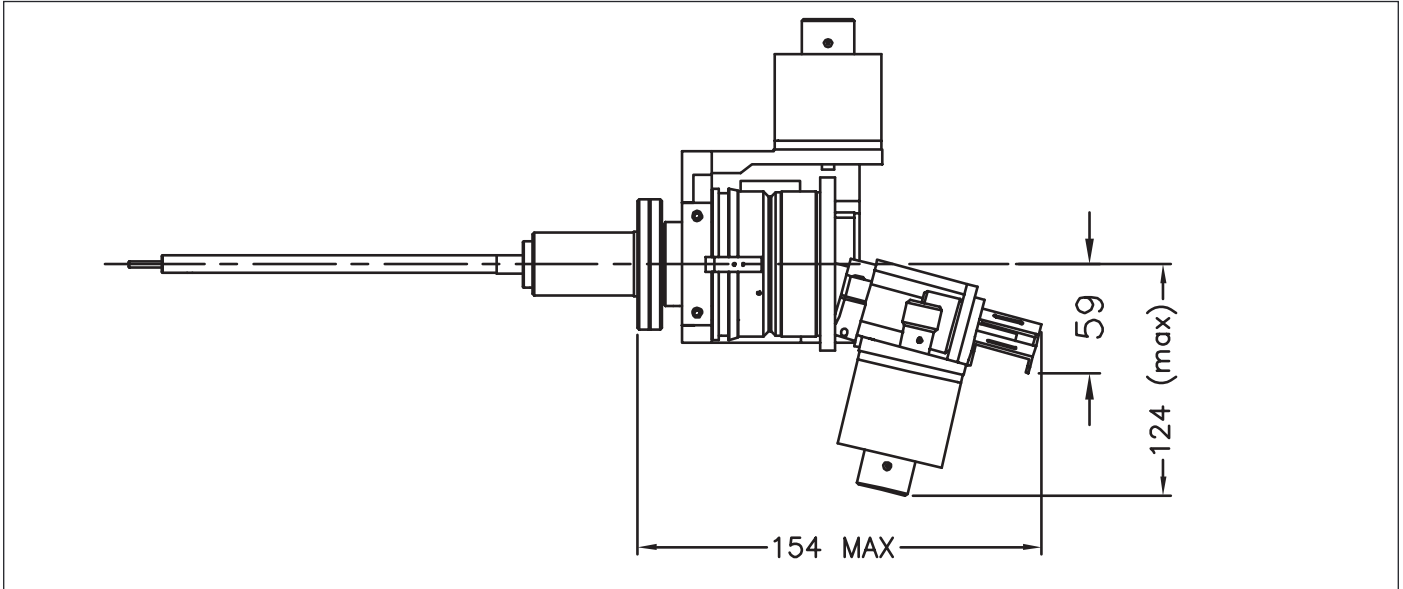

RD2 (Primary and Secondary) Series Rotary Drive

Flange OD mm	Flange OD inch	Primary Rotation	Linear Secondary Motion	Resolution Primary Degrees	Resolution Secondary mm	Torque Primary	Torque Primary	Gearbox ratio	Order Code
70	2.75	Continuous*	12mm	0.1	0.02	0.5Nm at 500 rpm	5Nm at 10 rpm	-	ZRD2
70	2.75	Continuous*	24mm	0.1	0.02	0.5Nm at 500 rpm	5Nm at 10 rpm	-	ZRD224
Stepper Motor Kit Primary (R1)	Stepper Motor Kit R1	Continuous*	-	0.01	-	4Nm at 16 rpm max	4Nm at 16 rpm max	-	ZRDPMKW
Stepper Motor + encoder Kit	Stepper Motor Kit R1	Continuous*	-	1.01	-	4Nm at 16 rpm max	4Nm at 16 rpm max	-	ZRDPMKE
Primary (R1) Stepper Motor Kit secondary (R2)	Stepper Motor Kit R2	-	max 24mm	0.01	18 steps per 0.005 mm	-	-	9:01	ZRD5MKW
Stepper Motor + encoder secondary (R2)	Stepper Motor Kit R2	-	max 24mm	1.01	18 steps per 0.005 mm	-	-	9:01	ZRD5MKE

* Continuous rotation where fixtures on the end of the rotary drive allow this