



# DAEWOO

POWER PRODUCTS

## DAAX24L-OF

**Air compressors**

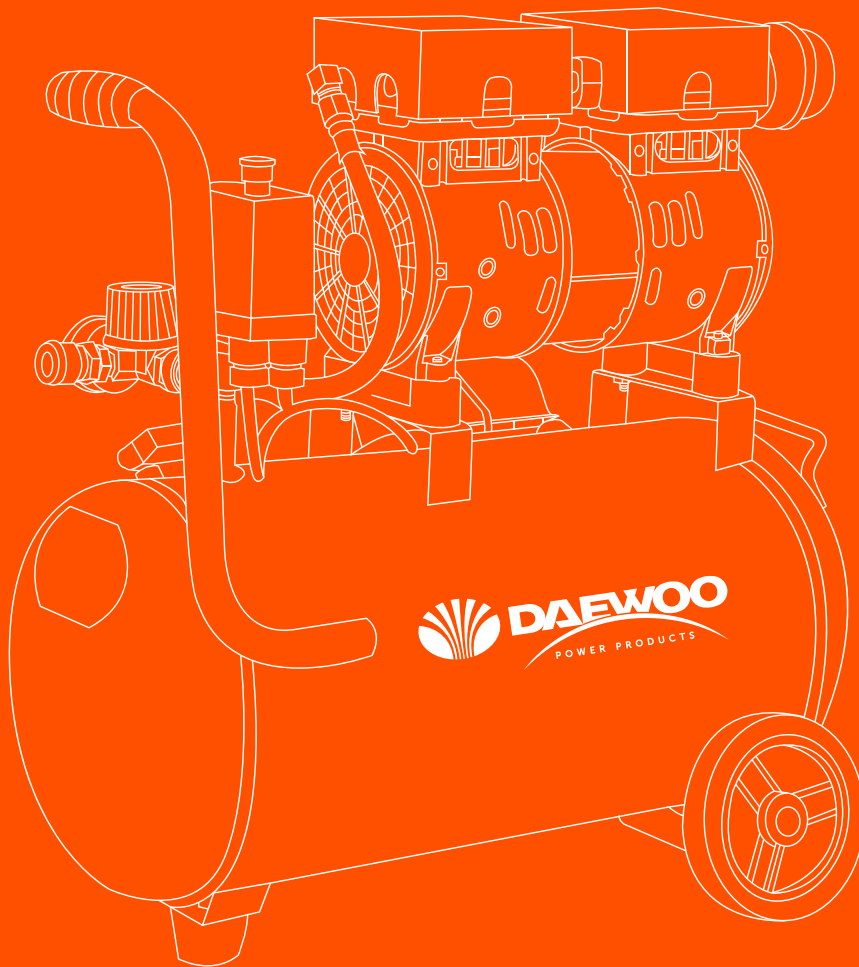

## USER'S MANUAL

[www.daewoopowerproducts.com](http://www.daewoopowerproducts.com)

Manufactured under license of Daewoo International Corporation, Korea

# INDEX

<b>1. OPERATING INSTRUCTIONS .....</b>	<b>2</b>
<b>2. GENERAL SAFETY INFORMATION .....</b>	<b>3</b>
<b>3. ASSEMBLY .....</b>	<b>4</b>
<b>4. MAIN TECHNICAL DATE .....</b>	<b>5</b>
<b>5. INSTALLATION .....</b>	<b>5</b>
<b>6. MAINTENANCE .....</b>	<b>8</b>
<b>7. TROUBLESHOOTING CHART .....</b>	<b>9</b>
<b>8. PARTS ILLUSTRATION .....</b>	<b>11</b>
<b>9. PARTS ILLUSTRATION LIST .....</b>	<b>12</b>
<b>WARRANTY .....</b>	<b>13</b>

## 1. OPERATING INSTRUCTIONS

Please read and save these instructions. Read carefully before attempting to assemble, install, operate or maintain the product described. Protect yourself and others by observing all safety information. Failure to comply with instructions could result in personal and/or property damage! Retain instructions for future reference.

### DESCRIPTION

Oilless air compressors are designed for do-it-yourselfers with a variety of home and automotive jobs. These compressors power spray guns, impact wrenches and other tools. These units operate without oil. Compressed air from this unit will contain moisture. Install a water filter or air dryer if application requires dry air.

### SAFETY GUIDELINES

This manual contains information that is very important to know and understand. This information is provided for SAFETY and to PREVENT EQUIPMENT PROBLEMS. To help recognize this information, observe the following symbols.

**⚠ DANGER!** Danger indicates an imminently hazardous situation, which, if not avoided, will result in death or serious injury.

**⚠ WARNING!** Warning indicates a potentially hazardous situation, which, if not avoided, could result in death or serious injury.

**⚠ CAUTION!** Caution indicates a hazardous situation, which if not avoided, may result in minor or moderate injury.

**⚠ NOTICE!** Notice indicates important information that if not followed, may cause damage to equipment.

**UNPICKING** After unpacking the unit, inspect carefully for any damage that may have occurred during transit. Make sure to tighten fittings, bolts, etc, before putting unit into service.

**⚠ WARNING!** Do not operate unit if damaged during shipment. Handling or use damage may result in bursting and cause injury or property damage.

#### **⚠ DANGER!** Breathable Air Warning

This compressor is not equipped and should not be used "as is" to supply breathing quality air. For any application of air for human consumption, the air compressor will need to be fitted with suitable in-line safety and alarm equipment.

## 2. GENERAL SAFETY INFORMATION

Since the air compressor and other components (material pump, spray guns, filters, lubricators, hoses, etc.) used, make up a high pressure pumping system, the following safety precautions must be observed at all times:

1. Read all manuals included with this product carefully. Be thoroughly familiar with the controls and the proper use of the equipment.
2. Follow all local electrical and safety codes.
3. Only persons well acquainted with these rules of safe operation should be allowed to use the compressor.
4. Keep visitors away and never allow children in the work area.
5. Wear safety glasses and use hearing protection when operating the compressor or unit.



6. Do not stand on or use the compressor or unit as a handhold.
7. Before each use, inspect compressed air system and electrical components for signs of damage, deterioration, weakness or leakage. Repair or replace defective items before using.
8. Check all fasteners at frequent intervals for proper tightness.

**⚠ WARNING!** Motors, electrical equipment and controls can cause electrical arcs that will ignite a flammable gas or vapor, Never operate or repair in or near a flammable gas or vapor, Never store flammable liquids or gases in the vicinity of the compressor.



**⚠ CAUTION!** Compressor parts may be hot even if the unit is stopped.

9. Keep fingers away from a running compressor, fast moving and hot parts will cause injury and/or burns.



10. If the equipment should start to abnormally vibrate, STOP the engine/motor and check immediately for the cause, vibration is generally a warning of trouble.

11. To reduce fire hazard, keep engine/motor exterior free of oil, solvent, or excessive grease.

**⚠ WARNING!** Never remove or attempt to adjust safety valve. Keep safety valve free from paint and other accumulations.

**⚠ DANGER!** Never attempt to repair or modify a tank! Welding, drilling or any other modification will weaken the tank resulting in damage from rupture or explosion . Always replace worn or damaged tanks.

**⚠ WARNING!** Drain liquid from tank daily.

13. Tanks rust from moisture build-up, which weakens the tank. Make sure to drain tank regularly and inspect periodically for unsafe conditions such as rust formation and corrosion.

14. Fast moving air will stir up dust and debris, which may be harmful. Release air slowly when draining moisture or depressurizing the compressor system.

### SPRAYING PRECAUTIONS

**⚠ WARNING!** Do not spray flammable material in vicinity of open flame or near ignition sources including the compressor unit.



15. Do not smoke when spraying paint, insecticides, or other flammable substances.

16. Use a face mask/respirator when spraying and spray in a well ventilated area to prevent health and fire hazards.



17. Do not direct paint or the other sprayed material at the compressor. Locate compressor as far away from the spraying area as possible to minimize overspray accumulation on the compressor.

18. When spraying or cleaning with solvents or toxic chemical ,following the instruction provided by the chemical manufacturer.

## 3. ASSEMBLY

### WHEEL ASSEMBLY

Fit the wheels shown in Figure 1.

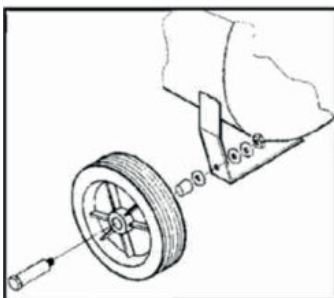

Figure 1

#### 4. MAIN TECHNICAL DATE

Model: DAAX24L-OF

Voltage/Frequency: 220-240 V/50 Hz

Power: 0.7 hp / 550 W

Tank capacity: 24 L

Speed: 1440 rpm

Max pressure: 8 bar/115 psi

Flow: 106 L/min

#### 5. INSTALLATION

##### LOCATION

It is extremely important to install the compressor in a clean , well ventilated area where the surrounding air temperature will not be more than 100°F.

A minimum clearance of 18inches between the compressor and a wall is required because objects could obstruct airflow.

**⚠ CAUTION!** Do not locate the compressor air inlet near steam ,paint spray, sandblast areas or any other source of contamination. This debris will damage the motor.

##### ELECTRICAL INSTALLATION

**⚠ WARNING!** All wiring and electrical connections should be performed by a qualified electrician. Installation must be in accordance with local codes and national electrical codes.

**⚠ CAUTION!** Never use an extension cord with this product. Use additional air hose instead of an extension cord to avoid power loss and permanent motor damage; Use of an extension cord voids the warranty.



##### GROUNDING INSTRUCTIONS

1. This product is for use on a nominal 230volt circuit and has a grounding plug that looks like the plug illustrated in Fig.2. Make sure the product is connected to an outlet having the same configuration as the plug. This product must be grounded. In the event of an electrical shock by providing an escape wire for electric current. This product is equipped with a cord having a grounding wire with an appropriate grounding wire with an appropriate grounding plug. Plug must be plugged into an outlet that is properly installed and grounded in accordance with all local codes and ordinances.

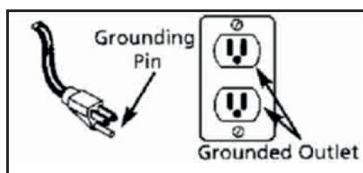

Figure 2

**⚠ CAUTION!** Improper use of grounding plug can result in a possible in a possible risk of electrical shock!



**⚠ DANGER!** Do not use a grounding adapter with this product!

2. If repair or replacement of cord or plug is necessary, do not connect grounding wire to either flat blade terminal. The wire with insulation having an external surface that is green(with or without yellow stripes) is the grounding wire.

**⚠ WARNING!** Never connect green (or green and yellow ) wire to a live terminal.

3. Check with a qualified electrician or serviceman if grounding instructions air not completely understood , or if in doubt as to whether product is properly grounded. Do not modify plug provided; If it will not fit outlet, have proper outlet installed by a qualified electrician.

4. Local electrical wiring codes differ from area to area. Source wiring, plug and protector must be rated for at least the amperage and voltage indicated on motor nameplate, and meet all electrical codes for this minimum.

5. Use a slow blow fuse or a circuit breaker.

## **OPERATION**

**Pressure Switch: Auto/Off Switch-**In the AUTO position , the compressor shuts off automatically when tank pressure reaches the maximum preset pressure. In the OFF position , the compressor will not operate. This switch should be in the OFF position when connecting or disconnecting the power cord from the electrical outlet or when changing air tools.

**Regulator:** The regulator controls the amount of air pressure released at the hose outlet.

**Safety Valve:** This valve automatically releases air if the tank pressure exceeds the preset maximum.

**Discharge Tube:** This tube carried compressed air from the pump to the check valve. This tube becomes very hot during use. To avoid the risk of severe burns, never touch the discharge tube.

**Check Valve:** A-one-way valve allows air to enter the tank ,but prevents air in the tank from flowing back into the compressor pump.

**Handle:** Designed to move the compressor.

**⚠ WARNING!** Never use the handle on wheeled units to lift the unit completely off the ground.

**Drain Petcock-** This valve us located on the bottom of the tank. Use this valve to drain moisture from the tank daily to deduce the risk of corrosion.

Reduce tank pressure below 10psi, and then drain moisture form tank daily to avoid tank corrosion.

Drain moisture from tank by opening the drain petcock located underneath the tank.

## LUBRICATION

This is an oilless product and does not require lubrication to operate.

## BREAK-IN PROCEDUR

**⚠ CAUTION!** Do not attach air chuck or other tool to open end of hose until start-up has been completed and unit checks ok.

**IMPROTANT:** Do not operate compressor before reading instructions or damage may result.

1. Turn regulate fully clockwise to open airflow.
2. Turn switch to OFF position and plug in power cord.
3. Turn switch to AUTO position and run unit for 30 minutes to break in the pump parts.
4. Turn regulator knob fully counterclockwise. Compressor will build to maximum preset pressure and shut off.
5. Turn regulator knob clockwise to cause air to bleed off. Compressor will result at a preset pressure.

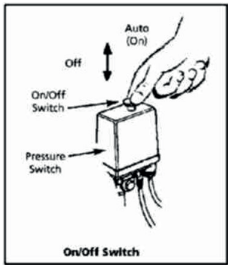

Figure 3

6. Turn regulator knob counterclockwise to shut off the air and turn switch to off position.
7. Attach chuck or other tool to open end of hose, Turn the regulator on. In the AUTO position, the compressor pumps air into the tank. It shuts off automatically when unit reaches its maximum preset pressure. In the OFF position, the pressure switch cannot function and the compressor will not operate. Make sure switch is in OFF position when connecting or disconnecting power cord from electrical outlet.

## MOISTURE IN COMPRESSED AIR

Moisture in compressed air will form into droplets as it comes from an air compressor pump. When humidity is high or when a compressor is in continuous use for an extended period of time, this moisture will collect in the tank. When using a paint spray or sandblast gun, this water will be carried from the tank through the hose, and out of the gun as droplets mixed with the spray material.

**IMPORTANT:** This condensation will cause water spots in a paint job, especially when spraying other than water based paints. If sandblasting, it will cause the sand to clump and clog the gun rendering it ineffective. A filter in the air line, located as near to the gun as possible, will help eliminate this moisture.

## SAFETY VALVE

**⚠ WARNING!** Do not remove or attempt to adjust the safety valve!

This valve should be checked under pressure occasionally by pulling the ring by hand. If air leaks after ring has been released, or valve is stuck and cannot be actuated by ring, it **MUST** be replaced.



### REGULATOR KNOB (figure 4)

1. This knob controls air pressure to an air-operated tool or paint spray gun.
2. Turn clockwise to increase air pressure at outlet. When desired pressure is reached, locked with nuts.
3. To lower air pressure at outlet, turning counterclockwise.

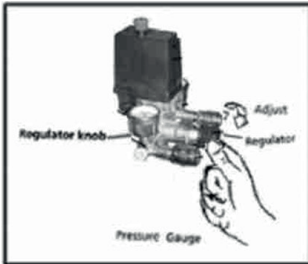

Figure 4

4. Turn fully counterclockwise to shut off flow of the air completely then push knob down.

### TANK PRESSURE GAUGE

Gauge shows pressure in tank indicating compressor is building pressure properly.

## 6. MAINTENANCE

**⚠ WARNING!** Disconnect power source then release all pressure from the system before attempting to install, service, relocate or perform any maintenance.

Check compressor often for any visible problems and follow maintenance procedures each time compressor is used.



**⚠ WARNING!** Safety valve must be replaced if it cannot be actuated or it leaks air after ring is released.

1. Pull ring on safety valve and allow it to snap back to normal position.
2. Turn compressor off and release pressure from system. Drain moisture from tank by opening drain cock underneath tank.
3. Clean dust and dirt from motor, tank and airlines and pump cooling fins while compressor from clogging filter.

**IMPORTANT:** Locate unit as far from spraying area, as hose will allow preventing overspray from clogging filter.

### LUBRICATION

This is an oilless type air compressor requiring no lubrication.

## THERMAL OVERLOAD PROTECTOR

### ⚠ CAUTION!

This compressor is equipped with an automatic reset thermal overload protector, which will shut off motor if it becomes overheated.

If thermal overload protector shuts motor OFF frequently, look for the following causes.

1. Low voltage.
2. Clogged air filter.
3. Lack of proper ventilation.

## 7. TROUBLESHOOTING CHART

SYMPTOM	POSSIBLE CAUSE (S)	CORRECTIVE ACTION
Compressor will not run	<ol style="list-style-type: none"> <li>1. No electrical power</li> <li>2. Blown fuse</li> <li>3. Breaker open</li> <li>4. Thermal overload open</li> <li>5. Pressure switch bad</li> </ol>	<ol style="list-style-type: none"> <li>1. Plugged in ? Check fuse/breaker or motor overload</li> <li>2. Replace blown fuse</li> <li>3. Reset, determine cause of problems</li> <li>4. Motor will restart when cool</li> <li>5. Replace</li> </ol>
Motor hums but cannot run or runs slowly	<ol style="list-style-type: none"> <li>1. Defective check valve or unloaded</li> <li>2. Poor contacts, line voltage low</li> <li>3. Shorted or open motor winding</li> </ol>	<ol style="list-style-type: none"> <li>1. Replace or repair</li> <li>2. Check connections, eliminate extension cork if used, check circuit with voltmeter.</li> <li>3. Replace motor</li> <li>DANGER! Do not disassemble check valve with air in tank; Bleed tank</li> </ol>
Fuses blow/circuit breaker trips repeatedly CAUTION! Never use an extension cord with this product	<ol style="list-style-type: none"> <li>1. Incorrect size fuse , circuit overloaded</li> <li>2. Defective check valve or unloaded</li> </ol>	<ol style="list-style-type: none"> <li>1. Check for proper fuse, use time-delay fuse. Disconnect other electrical appliances from circuit or operate compressor on its own branch circuit</li> <li>2. Replace or repair</li> <li>DANGER! Do not disassemble check valve with air in tank; bleed tank</li> </ol>
Thermal overload protector cuts out repeatedly	<ol style="list-style-type: none"> <li>1. Low voltage</li> <li>2. Clogged air filter</li> <li>3. Lack of proper ventilation/room temperature too high</li> <li>4. Check valve malfunction</li> <li>5. Compressor valves failed</li> </ol>	<ol style="list-style-type: none"> <li>1. Eliminate extension cord, check with voltmeter</li> <li>2. Clean filter (see Maintenance section)</li> <li>3. Move compressor to well ventilated area</li> <li>4. Replace</li> <li>5. Replace valve assembly</li> <li>DANGER! Do not disassemble check valve with air in tank; bleed tank</li> </ol>
Thermal overload protector cuts out repeatedly	<ol style="list-style-type: none"> <li>1. Low voltage</li> <li>2. Clogged air filter</li> <li>3. Lack of proper ventilation/room temperature too high</li> <li>4. Check valve malfunction</li> <li>5. Compressor valves failed</li> </ol>	<ol style="list-style-type: none"> <li>1. Eliminate extension cord, check with voltmeter</li> <li>2. Clean filter (see Maintenance section)</li> <li>3. Move compressor to well ventilated area</li> <li>4. Replace</li> <li>5. Replace valve assembly</li> <li>DANGER! Do not disassemble check valve with air in tank; bleed tank</li> </ol>

<p><b>Knocks, rattles excessive vibration</b></p>	<ol style="list-style-type: none"> <li>1. Loose bolts, tank not level</li> <li>2. Defective bearing on eccentric or motor shaft</li> <li>3. Cylinder or piston ring is worn or scored</li> </ol>	<ol style="list-style-type: none"> <li>1. Tighten bolts, shim tank to level position</li> <li>2. Replace</li> <li>3. Replace or repair as necessary</li> </ol>
<p><b>Tank pressure drops when compressor shuts off</b></p>	<ol style="list-style-type: none"> <li>1. Loose drain cock</li> <li>2. Check valve leaking</li> <li>3. Loose connections at pressure switch or regulator</li> </ol>	<ol style="list-style-type: none"> <li>1. Tighten</li> <li>2. Disassemble check valve assembly, clean or replace</li> <li>3. Check all connections with soap and water solution and tighten</li> </ol>
<p><b>Compressor runs continuously and air output is lower than normal/low discharge pressure</b></p>	<ol style="list-style-type: none"> <li>1. Excessive air usage, compressor too small</li> <li>2. Clogged intake filter</li> <li>3. Air leaks in piping (on machine or in outside system)</li> <li>4. Broken inlet valves</li> <li>5. Piston ring worn</li> </ol>	<ol style="list-style-type: none"> <li>1. Decrease usage or purchase unit with higher air delivery (SCFM)</li> <li>2. Clean or replace</li> <li>3. Replace leaking components or tighten as necessary</li> <li>4. Replace compressor valves</li> <li>5. Replace piston and cylinder</li> </ol>
<p><b>Excessive moisture in discharge air</b></p>	<ol style="list-style-type: none"> <li>1. Excessive water in tank</li> <li>2. High humidity</li> </ol>	<ol style="list-style-type: none"> <li>1. Drain tank</li> <li>2. Move to area of less humidity ; use air line filter</li> </ol> <p>NOTE: Water condensation is not caused by compressor malfunction</p>
<p><b>Compressor runs continuously and safety valve opens as pressure rises</b></p>	<ol style="list-style-type: none"> <li>1. Defective pressure switch</li> <li>2. Defective safety valve</li> </ol>	<ol style="list-style-type: none"> <li>1. Replace switch</li> <li>2. Replace safety valve with genuine replacement part</li> </ol>
<p><b>Excessive starting and stopping (auto start)</b></p>	<p>Excessive condensation in tank</p>	<p>Drain more often</p>
<p><b>Air leaking from unloader on pressure switch</b></p>	<p>Check valve stuck in an open position</p>	<p>Remove and replace check valve <b>DANGER!</b> Do not disassemble check valve with air in tank ; bleed tank</p>

## 8. PARTS ILLUSTRATION

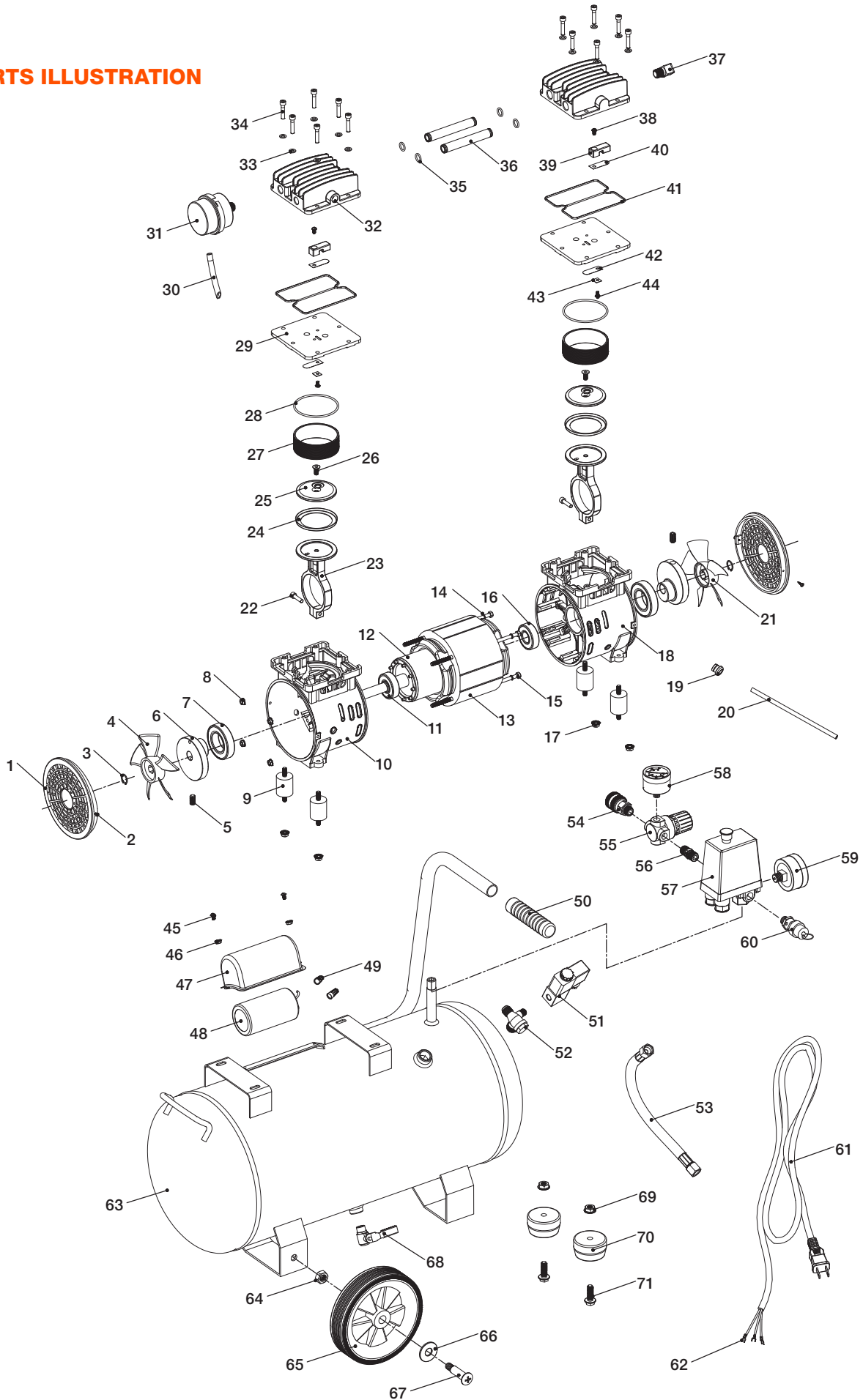

## 9. PARTS ILLUSTRATION LIST

No.	Name	QTY
1	Fan cover	2
2	Bolt	4
3	Locking ring	2
4	Lenft fan	1
5	Bolt	4
6	Crank	2
7	Bearing	2
8	Nut	4
9	Shock relief foot pad	4
10	Left crankcase	1
11	Bearing	1
12	Rotor	1
13	Stator	1
14	Lock washer	4
15	Bolt	4
16	Bearing	1
17	Nut	4
18	Right crankcase	1
19	Wire fasten ring	1
20	Shrinkable tube	2
21	Right fan	1
22	Bolt	2
23	Connect rod	2
24	Piston ring	2
25	Fasten plate	2
26	Bolt	2
27	Cylinder	2
28	O-ring	2
29	Valve plate	2
30	Air pipe	1
31	Air filter	1
32	Cylinder cover	2
33	Plain washers	8
34	Bolt	8
35	O-ring	4
36	Connect pipe	2
37	Exhaust head	1
38	Bolt	2
39	Fasten part	2
40	Exhaust valve	2
41	Cylinder cover seal ring	2
42	Intake valve	2
43	Metal cushion	2
44	Bolt	2
45	Bolt	2
46	Nut	2

No.	Name	QTY
47	Capacitor protector	1
48	Capacitor	1
49	Terminal cap	2
50	Handle grip	1
51	Magnetic valve	1
52	Check valve	1
53	High pressure soft tube	1
54	Quick connect	1
55	Regulator valve	1
56	Connector	1
57	Pressure switch	1
58	Pressure gauge	1
59	Pressure gauge	1
60	Safety valve	1
61	Power cord	1
62	Terminal block	6
63	Tank	1
64	Dain valve	1
65	Nut	2
66	Wheel	2
67	Plain washers	2
68	Axle	2
69	Nut	2
70	Foot pad	2
71	Bolt	2

## DECLARATION OF CONFORMITY

We: TAIZHOU JINGTAI ELECTRIC MACHINERY CO.,LTD

DONGLUO VILLAGE,BINHAI TOWN,WENLING CITY,TAIZHOU,ZHEJIANG  
CHINA.

Declare that the Product detailed below:

AIR COMPRESSOR  
Model: DAAX24L-OF

Brand:  **DAEWOO**

Satisfies the requirement of the Council Directives:  
Machinery Directive 2006/42/EC  
Low Voltage Directive 2014/35/EU  
Electromagnetic Compatibility 2014/30/EU

Name and address of authorized person to compile the technical file:  
Zhejiang European African Testing&Certification Co.,Ltd  
4th Floor,Building 4.No 888 Donghuan Road,Development Zone,Taizhou City,Zhejiang P.R China

Notified body: ISTITUTO SERVIZI EUROPEI TECNOLOGICI  
Number of notified body:0805

and conforms to the norms:  
EN ISO 12100: 2010,EN 1012-1:2010,EN 60204-1:2018,EN IEC 61000-6-1:2019,  
EN 61000-6-3:2007+A1:2011+AC:2012,EN IEC61000-3-2:2019,EN 61000-3-3:2013+A1:2019

Position of Signatory: Director of research and development department  
Mr zhao.

Date: January, 2022  
Taizhou , Zhejiang , CHINA

台州精泰电机股份有限公司  
TAIZHOU JINGTAI  
ELECTRIC MACHINERY CO., LTD.



## WARRANTY CARD

Product model	Date of sale
Serial number	Company
Username	Client's signature

The product is in good conditions and fully complete. Read and agree the terms of the warranty.

## GUARANTEE

The warranty period starts from the date of sale of the products and covers 2 years for all power products.

During the warranty period, free failures caused due to the use of poor-quality materials in the production and manufacturer workmanship admitted fault are removed. The guarantee comes into force only when warranty card and cutting coupons are properly filled. The product is accepted for repair in its pure form and full completeness.

## WARRANTY DOES NOT COVER

- Mechanical damage (cracks, chips, etc.) and damage caused by exposure to aggressive media, foreign objects inside the unit and air vents, as well as for damage occurred as a result of improper storage (corrosion of metal parts);
- Failures caused by overloading or product misuse, use of the product for other purposes. A sure sign of overload products is melting or discoloration of parts due to the high temperature, simultaneous failure of two or more nodes, teaser on the surfaces of the cylinder and the piston or destruction of piston rings. Also, the warranty does not cover failure of the automatic voltage regulator due to incorrect operation;
- Failure caused by clogging of the fuel and cooling systems;
- Wearing parts (carbon brushes, belts, rubber seals, oil seals, shock absorbers, springs, clutches, spark plugs,

- mufflers, nozzles, pulleys, guide rollers, cables, recoil starter, chucks, collets, removable batteries, filters and safety elements, grease, removable devices, equipment, knives, drills, etc.);
- Electrical cables with mechanical and thermal damage;
- Product opened or repaired by a non-authorized service center.
- Prevention, care products (cleaning, washing, lubrication, etc.), installation and configuration of the product;
- Natural wear products (production share);
- Failures caused by using the product for the needs related to business activities;
- If the warranty card is empty or missing seal (stamp) of the Seller;
- The absence of the holder's signature on the warranty card.

<b>DAEWOO</b>		
Product _____	Product _____	Product _____
Model _____		Model _____
Company _____	Company _____	Company _____
Date of sale _____	Date of sale _____	Date of sale _____



**DAEWOO**  
POWER PRODUCTS

[www.daewoopowerproducts.com](http://www.daewoopowerproducts.com)

Manufactured under license of Daewoo International Corporation, Korea