

■ Main Specifications

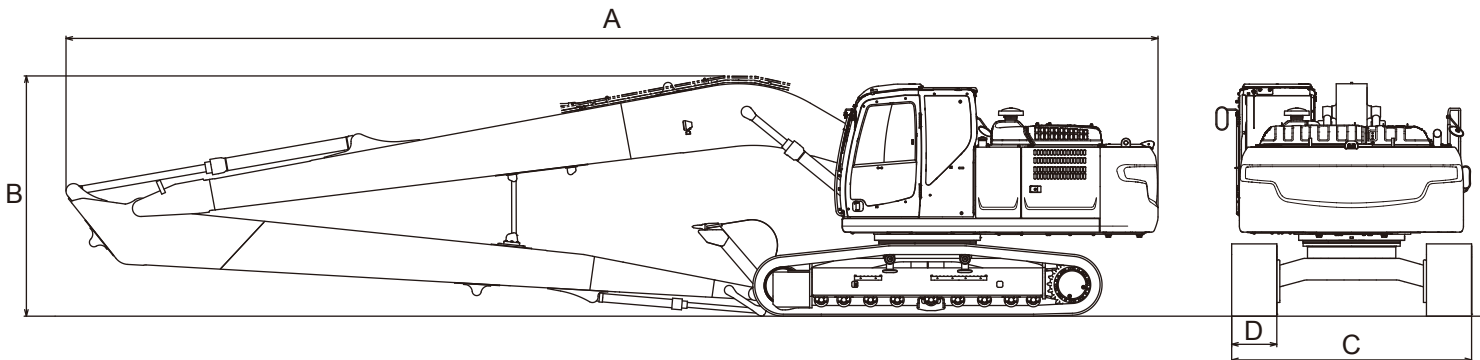

Model		SK210LC	SK260LC
Long reach attachment		50ft	60ft
Engine		HINO J05E-UM-KSSC	HINO J05E-UN-KSSD
Rated power output(ISO 14396 : Without fan)	kW/min ⁻¹	124/2,000	138/2,100
Swing speed	min ⁻¹	12.5	10.2
Operating weight	kg	23,100	27,800
Ground pressure	kPa	48	55
A. Overall length	mm	12,690	14,520
B. Overall height	mm	3,160	3,190
C. Overall width	mm	2,990	3,190
D. Shoe width	mm	600	600

■ Working Ranges

Unit: mm

	SK210LC	SK260LC
Boom	8.75m	10.35m
Range / Arm	6.35m	8.25m
a- Max. digging reach	15,820	18,530
b- Max. digging reach at ground level	15,710	18,440
c - Max. digging depth	12,010	14,730
d- Max. digging height	13,900	14,590
e- Max. dumping clearance	11,530	12,320
f - Min. dumping clearance	2,080	1,570
g- Max. vertical wall digging depth	11,170	12,320
h- Min. swing radius	4,720	5,600
i - Horizontal digging stroke at ground level	11,610	14,770
j - Digging depth for 2.4 m (8') flat bottom	11,910	14,580
Bucket capacity ISO heaped m ³	0.45	0.40

