

Preface

This Cross-Border Payment Reporting plus (CBPR+) User Handbook is intended to document and explain a variety of ISO 20022 payment related topics, as well as provide practical use cases to ensure a common understanding and adoption of ISO 20022 within the payment industry.

The SWIFT FINplus service will support CBPR+ messages on the SWIFT network traditionally associated with correspondent banking (many-to-many). These messages may be exchanged either between Agents in the same country or between Agents in different countries.

The use cases focus on a core topics where other relevant messages may also be referred to within the use case, it may also be necessary to consider other documented use cases, in order to capture a wider variation of scenarios.

Note:

This document jointly developed with the CBPR+ group continues to evolve **inline with the Standards Release** as:

- CBPR+ continue to develop market practice guidelines for additional message.
- Inaccuracies are identified and corrected.
- Further use cases and/or explanation needs are identified



Change log (since last iteration)

Page 2	Updated – note
Page 5	Updated – new messages added to index
Page 6	Updated – new messages added to index
Page 11	Updated – correction of Intermediary code
Page 33	Updated – new messages and Usage Ids added
Page 40	Updated – new pain message added to index
Page 45	Updated – recognition of Payment Initiation relay rulebook
Page 107	Updated – recognition of Payment Initiation relay rulebook
Page 122	Updated – additional use cases in the index
Page 126	New –use case
Page 134	New – use case
Page 135-182	New – pain.008 message section
Page 184	Update – new messages added to index
Page 204	Update – removed refer to Wait For Settlement Market Practice
Page 351	New – new high level message flow
Page 371	Updated – new messages added to index
Page 379-380	New – pacs.003 use cases
Page 400	Updated – additional guidance on ultimate parties on the return
Page 423	Updated – correct to Agent description in Step 7
Page 458-488	New – pacs.010 Margin Collection section
Page 489-529	New – pacs.003 Customer Direct Debit section
Page 530	Updated – new message added to index
Page 674	Updated – removed reference to SR 2023
Page 682	Updated – moved reference to multiple notification, now at an <i>Item</i> level
Page 691	Updated – reference to multiple notification item Rule
Page 698-716	New – camt.058 Notice to Received Cancellation section
Page 743	Updated - new message added to index
Page 764	Updated - use case id correction
Page 774-795	New – Customer Cancellation Request section
Page 823-883	New – Cheque message sections
Page 880	Updated - use case id correction



The following icons dignify changes to slide from the previous iteration. Updates to text on a slide are captured in **gold**.



New slide since last iteration



Slide updated since last iteration

Legend

- Message type and direction
- Optional Message type and direction
- Focal Message type and direction

- pacs Debtor
- pacs Creditor
- pacs.008 Ultimate Debtor
- pacs.008 Ultimate Creditor
- Initiating party on behalf of the Debtor
- Agent
- Agent processing legacy format during a coexistence period
- Market Infrastructure
- Exceptional circumstance

- Exception & Investigation Case Assigner
- Exception & Investigation Case Assignee
- Statement Account Owner
- Statement Account Servicer
- Statement Authorised Party
- Shortcut to other part of document
- Extra attention is needed
- Legacy FIN MT message
- gpi Tracker
- Use Case variation

- Payment Initiation (pain)
- Payment Clearing and Settlement (pacs)
- Cash Management Reporting (camt)
- Cash Management Exception & Investigations (camt)
- Focus message
- Element Hierarchy Path
- Nested Element
- Element Choice
- Nested Element involving a choice
- New slide since last iteration
- Slide updated since last iteration
- Best practice





Table of contents

1. Introduction to ISO 20022

2. Business Application Header

3. Payment Initiation (pain)

[pain.001 - Interbank Customer Credit Transfer Initiation](#)

[pain.002 - Interbank Customer Payment Status Report](#)

[pain.008 – Customer Direct Debit Initiation](#) new for SR2023

4. Payment, Clearing and Settlement (pacs) messages

[pacs.002 – Financial Institution to Financial Institution Payment Status Report](#)

[pacs.004 – Payment Return](#)

[pacs.003 – Financial Institution to Financial Institution Customer Direct Debit](#) new for SR2023

[pacs.008 - Financial Institution to Financial Institution Customer Credit Transfer](#)

[pacs.009 \(core\) - Financial Institution Credit Transfer](#)

[pacs.009 \(cov\) - Financial Institution ‘Cover’ Credit Transfer](#)

[pacs.009 \(adv\) – Financial Institution ‘Advice’ Credit Transfer](#)

[pacs.010 – Financial Institution Direct Debit](#)

[pacs.010 – Financial Institution Direct Debit – Margin Collection](#) new for SR2023





Table of contents (continued)

5. Cash Management Reporting (camt) messages

[camt.052 - Bank to Customer Account Report](#)

[camt.053 - Bank to Customer Statement](#)

[camt.054 - Bank to Customer Debit Credit Notification](#)

[camt.057 – Notification to Receive](#)

[camt.058 – Notification to Receive Cancellation Advice](#) new for SR2023

6. Cash Management Exception & Investigation (camt) messages

[camt.029 - Resolution of Investigation](#)

[camt.055 – Customer Payment Cancellation Request](#) new for SR2023

[camt.056 - FI to FI Cancellation Request](#)

7. Cheques

[camt.107 – Cheque Presentment Notification](#) new for SR2023

[camt.108 – Cheque Cancellation or Stop Notification](#) new for SR2023

[camt.109 – Cheque Cancellation or Stop Report](#) new for SR2023

Introduction to ISO 20022



Introduction to ISO 20022

ISO 20022 introduces a fundamental change to the traditional language used by the payments industry for several decades. It also describes participants (i.e., parties) to a business transaction differently based upon the business domain (area) being described, in a similar way you may describe a person as a colleague, parent or sibling depending upon the context you wish to describe them. This section is designed to capture and explain some of the differences.



Introduction to ISO 2022 – Business Domains

Domains

Payment and Cash Management

Securities

Trade Services

Foreign Exchange

Card Payment

Message Definitions

acmt	Account Management
auth	Authorities
camt	Cash Management
pacs	Payment Clearing and Settlement
pain	Payment Initiation
remt	Payment Remittance Advice

Message Sets

camt.052 Bank to Customer Account Report
camt.053 Bank to Customer Statement
camt.054 Bank to Customer Debit Credit Notification
camt.056 FI to FI Payment Cancellation Request
camt.057 Notification to Receive

pacs.002 FI to FI Payment Status Report
pacs.004 Payment Return
pacs.008 FI to FI Customer Credit Transfer
pacs.009 Financial Institution Credit Transfer

pain.001 Customer Credit Transfer initiation
pain.002 Customer Payment Status Report
pain.012 Creditor Payment Activation Request

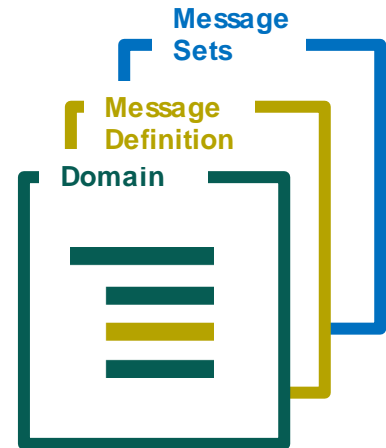

ISO 2022 catalogue messages hierarchically beginning with a Business Domain, contain a various sets of Message Definitions, which in turn contain a variety of Message Sets.

for example:

- Payment and Cash Management
 - Payments Clearing and Settlement
 - FI to FI Customer Credit Transfer (pacs.008)



Introduction to ISO 20022 - Message Identifier

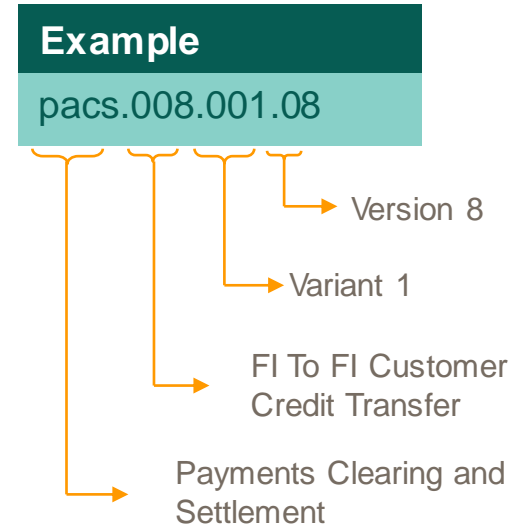
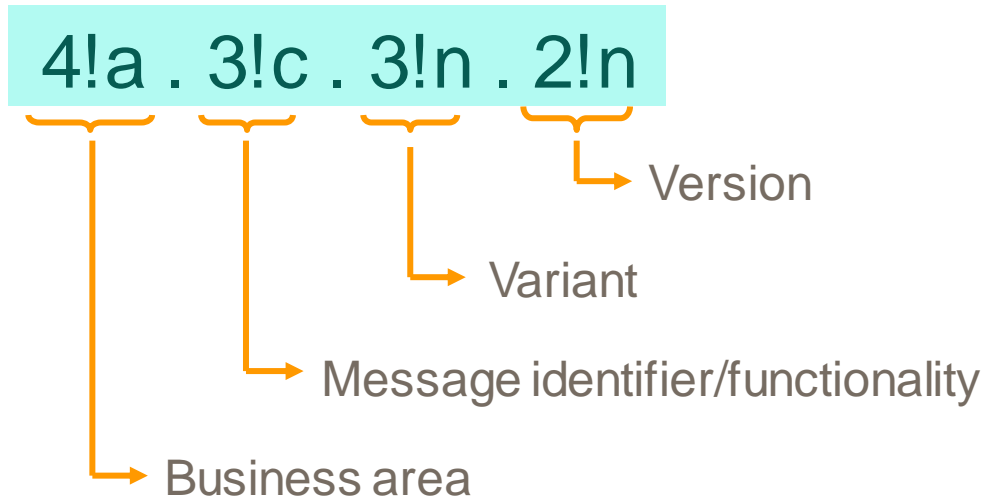

What is changing? Party Identifiers

Legend:

ISO 2022



New parties introduced in ISO 2022



:XX FIN MT format equivalent

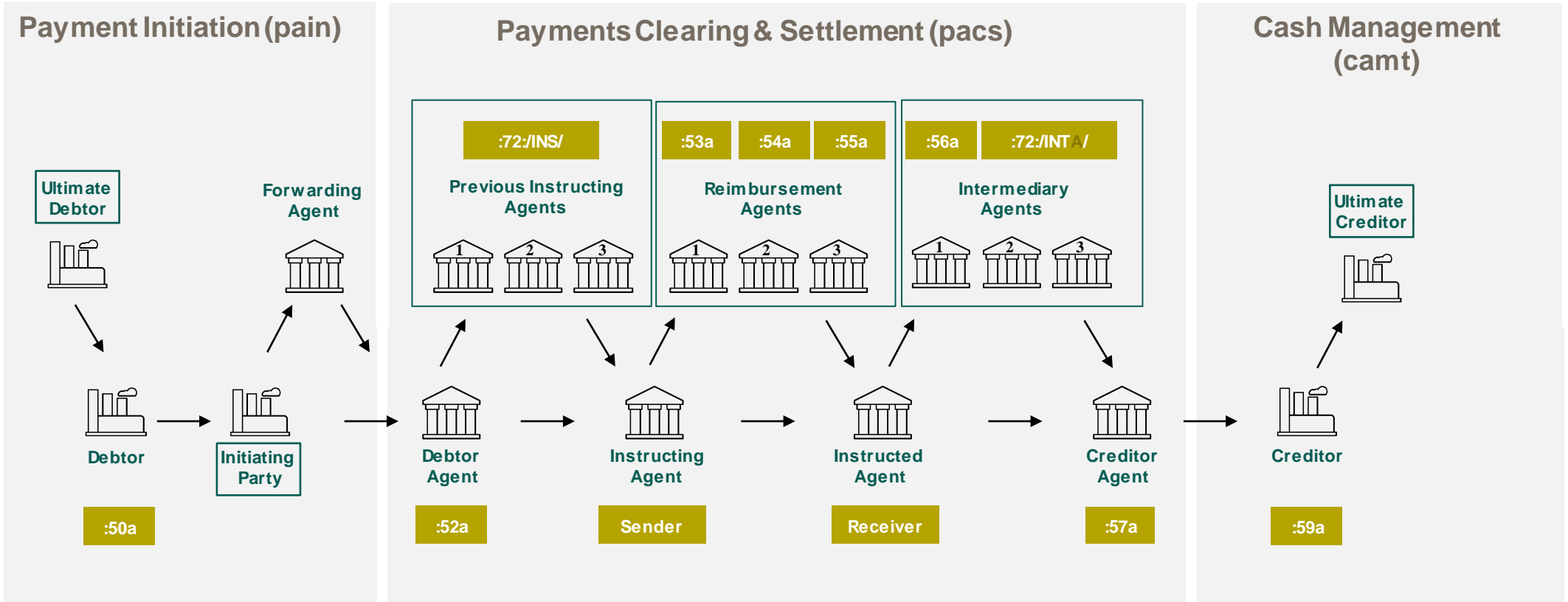

SWIFT FINplus Message structure

The diagram attempts to explain the construct of an ISO 2022 message sent across the SWIFT network using the **FINplus** service (which is designated to support various ISO 2022 business domains on SWIFT Interact)

Within the CBPR+ User Handbook the predominant focus is on the **Request Payload**, as this is where the business information is contained. However, it is worth noting that a network provider will have additional containers around the Request Payload to perform functionality on its network. This diagram presents the additional containers on the SWIFT network such as the Request Header often referred to as the Technical Header of the message.

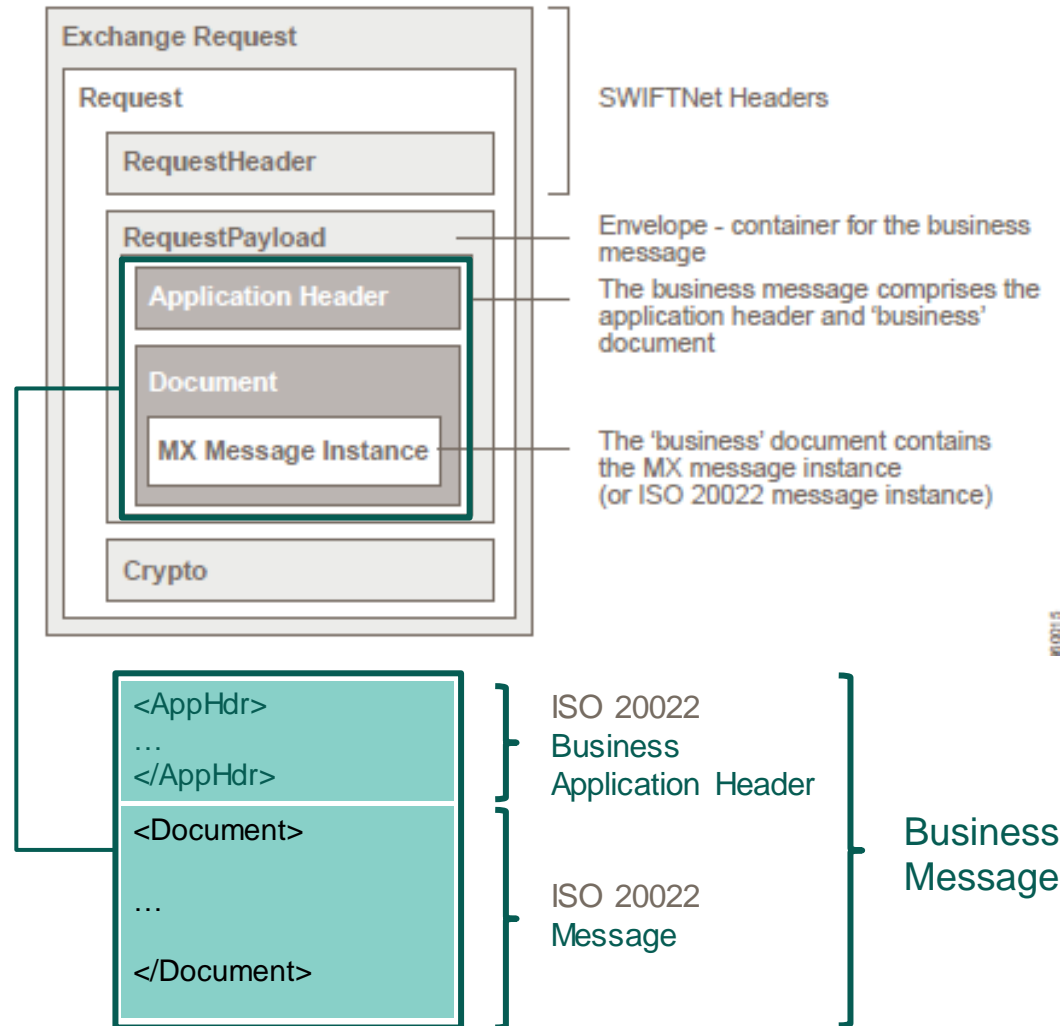

XML Elements

XML Elements

An XML instance or document contains data in elements and nested elements (elements which contain other elements) corresponding to the hierarchy imposed by the XML schema. In the CBPR+ Usage Guidelines we often refer to the element hierarchy by levels (to understand the nested relationship) whereby a Level 2 element effectively is a sub-element or child of another element. For example in a pacs.008 Customer Credit Transfer the *Interbank Settlement Date* is a sub-element (Level 2) of the *Credit Transfer Transaction Information* element (Level 1).

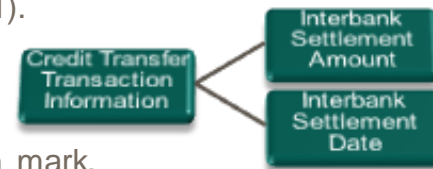

Naming conventions

An XML element is named according to the following rules:

- The name can contain letters, numbers, and other characters, but must not start with a number or punctuation mark.
- The name must not start with XML, xml, or Xml.
- The name must not contain any spaces.

MX naming conventions

There are some generic naming rules that apply to most items in the database.

- The names of all items in the database use the upper CamelCase convention, as follows:
 - Each word starts with a capital letter.
 - There are no white spaces between words.
- A name may be made up of multiple words, each consisting of alphanumeric characters.
- Words use British English vocabulary.
- All names must start with an alphabetic character.
- All characters that follow the first characters must be letters or numbers.

Example of a Street Name element: <StrtNm>Oxford Street</StrtNm>

Min	Max	Element Multiplicity
1	1	Required element
0	1	Optional element
0	*	Unlimited element occurrences

MX message element multiplicity (occurrences)

An MX message element specifies its cardinality (number of elements in a set) using minimum (min) & maximum (max) to describe the occurrences.



XML Elements (continued)

Empty XML Elements

An empty XML element is an element that contains no data content and therefore is described as empty. Although this makes little business sense, this is a known feature of XML. It typically only occurs where a nested element beneath a parent element allows for various element options but does not either enforce the use of an element with a minimum of 1 occurrence or does not have a rule defining the presence of at this one of the nested element.

A common example of this is in payment message is Financial Institution.

▼ ● Financial Institution Identification	1	1
> ● BICFI	0	1
> ● Clearing System Member Identification	0	1
● LEI	0	1
● Name	0	1
> ● Postal Address	0	1

Whereby technically it is possible to provide just Financial Institution without BICFI, or Name and Postal Address as an example i.e., `<FinInstnId></FinInstnId>`

In the **FINplus** service Message Validation (MVal) will validate the messages to ensure empty XML elements are not provided. i.e., ensure where business data should be provided within a nested element, it is provided.



XML Elements within CBPR+ User Hand Book

MyStandards describes the element's context by its path whereby each element is divided by a forward slash (/) For example the pacs.008 Town Name within the Debtor Postal Address is described as /Document/FIToFICstmrCdtTrf/CdtTrfTxInf/Dbtr/PstlAdr/TwnNm

Within the CBPR+ a similar Path principal is often used to visualize an element being explained, where the name is expanded rather than describing the element in an XML naming convention.

For example to describe the pacs.008 Payment Identification, the following is displayed on the bottom right hand side of the page to explain Payment Identification is an element below Credit Transfer Transaction Information.

Credit Transfer Transaction Info  *Payment Identification*

In this way the CBPR+ User Hand Book uses three main icon to explain the relationships between element, by display the icon after the element name.



To visualise an element which has nested elements beneath it



To visualise an element which has a choice associated with it i.e., a Code where a choice of which code can be determined



To visualise an element which is nested and has a choice associated with it. For example, an Identification where a choice must be made between an Organisation Identification and a Private Identification element which is nested, but where both cannot be used together.

The CBPR+ group has published all its usage guidelines in MyStandards

Swift MyStandards Search Standards Releases CBPR+ Swift Guidelines Groups

CBPR+

Cross-Border Payments and Reporting Plus (CBPR+) specifications define how ISO 20022 is used for cross-border payments and cash reporting on the Swift network. Conformance to CBPR+ specifications will be validated by Swift messaging services and interfaces, so it is imperative that users implement the specifications correctly. The resources available on this page aim to help Swift's community to understand and implement CBPR+ specifications.

[Learn more about ISO 20022 Readiness >](#)

[CBPR+ Usage Guidelines and Readiness Portal](#) [CBPR+ Translation Portal](#)

Additional resources

Find out how ISO 20022 is used for cross-border payments and cash reporting on the Swift network.

Document centre

CBPR+ user handbook Explains how CBPR+ Usage Guidelines support common business scenarios in cross-border payment and reporting processes. Download >	Data integrity market practice guidance Defines recommended market practices to report truncated or missing payment information using the MT messaging standard. Download >	CBPR+ and HVPS+ alignment Lists the similarities and differences between the two market practice sets. Download >
Derived data mapping guidance Provides guidance on how to populate information from one messaging standard to the other subsequent message. Download >	MT / MX equivalence table Documents the CBPR+ Usage Guidelines supported on Swift InterAct FINplus service in comparison with the equivalent MT message. Download >	Lessons learnt since go-live This document intends to provide guidance to the community regarding observations that may be identified before or after the migration. Download >

Samples library

CBPR+ sample messages Sample messages sets to test the use cases described in the CBPR+ user handbook. Learn more >	In-flow translation service sample messages Sample test messages for the In-flow translation service. Learn more >
---	--

<https://www2.swift.com/mystandards/#/c/cbpr/landing>



Message Usage Guideline – Additional Information and principals

CBPR+ Cross Border Payments and Reporting Plus PUBLISHED MyStandards

CBPR+ **CBPRPlus-pacs.008.001.08_FIToFICustomerCreditTransfer**
CBPRPlus_ISO 2022 Portfolio_November 2022_Release 2.0 (Technical version: 1 , Version: V2.0 FOR IMPLEMENTATION , Format: MX , Status: Final)
Usage Identifier: swift.cbprplus.01 Version: V2.0 FOR IMPLEMENTATION Status: Final

Content Result View History Sample Messages

Show xml tags

credit Transfer V08 (pacs.008.001.08)

Many of the CBPRplus Usage Guidelines have useful key principals and additional information. These can be expanded in MyStandards by clicking on 'show details' in the middle of the Usage Guideline description pane.

Hide details

Publisher	Cross Border Payments and Reporting Plus (CBPR+)	Publisher
Technical version	1	
Version	V2.0 FOR IMPLEMENTATION	
Status	Final	
Standard	pacs.008.001.08	
Format	MX	
Usage Identifier	swift.cbprplus.01	
Documents	For direct download	For PDF generation
+ add ?		
Description	Principles:	
	1A. AGENTS IDENTIFICATION -RECOMMENDATION	
	-> If BIC is present, then (Name & Postal Address) is NOT allowed (ClearingSystemMemberIdentification and LEI may complement) – However, in case of conflicting information, the BIC will always take precedence.	
	-> If BIC is absent, (Name & Postal Address) or ClearingSystemMemberIdentification must be present and both are allowed together.	
	Note: "Instructing/ Instructed Agents" must be identified with a BIC - Clearing System Members Identification and LEI are optional.	
	1B. DEBTOR/CREDITOR - PARTY IDENTIFICATION -RECOMMENDATION	
	-> If Any BIC is present, then (Name and Postal Address) is NOT allowed (other elements remain optional) - However, in case of conflicting information, AnyBIC will always take precedence.	
	-> If Name is present, it is recommended to use Postal Address.	
	2. Single transactions only are allowed.	



Rules

Traditionally in the Legacy FIN standard rules related to a message were described as either **Network Validation Rules** – those validated by the network, or **Usage rules** – rules not validated by the network. FIN also has the concept of **Usage Guidelines** – guideline to recommend a best practice.

In ISO 20022 there are similar rules (described in a different way) within a baseline message, and potentially within a dedicated Usage Guideline (e.g. CBPR plus)

Within CBPR+ Usage Guideline specification the rules dedicate to CBPR+ are often described as:

Formal Rules which are validated on the network, these are identified by the word **Rule** appended to the rule description. For example:  **Rule “CBPR_Party_Name_Any_BIC_FormalRule”**

Textual Rules which are not validated on the network, these are identified by with the word **TextualRule** appended to the rule description. For example:  **Rule “CBPR_Agent_Option_1_TextualRule”**

Guideline Rules which provide recommended best practice, these are identified by the word **Guideline** appended to the rule description. For example:  **Rule “CBPR_Purpose_Guideline”**

Rules inherited from the baseline message and validated on the SWIFT network are referred to in the Usage Guidelines as a **CrossElementSimpleRule** and a **CrossElementComplexRule**



Usage Identifier – Format

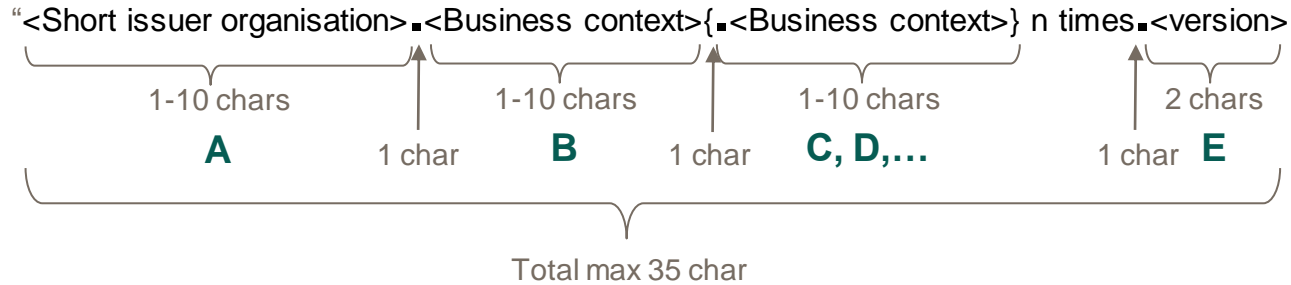

- Type: **String**
- Max allowed size: **35 characters**
- Structure:
 - Must contain minimum **A & B**, optionally followed by 1 or more additional business context elements (**C, D, ...**).
 - Always **ends** with **version element E** (format “nn”, e.g., “01”)
 - Each element is separated by a period “.”
 - Length of **each** text element **can vary** up to **max 10** characters. Total length, including periods, cannot exceed 35 chars.
 - Consistency enforced by lightweight SWIFT review/registration: E.g., “ecb” to represent the ECB, not “eucb”
 - **Lowercase** alphanumerical characters only



In CBPR+ the Usage Identifier is captured within the *Business Application Header*, **Business Service** element. More detail can be found in the dedicated Business Application Header chapter of this document,

ISO 2022 External Code Lists

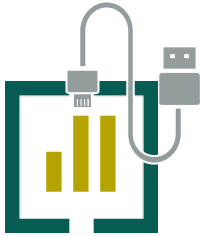

Many ISO 2022 message use data elements represented by codes. Such codes are often externalised from the message itself, enabling maintenance of the code list on a quarterly basis without requiring a new message version.

Some data element may also be embedded in the message.

example of Charge Bearer in pacs.008 v8 which uses embedded codes

▼ Charge Bearer	1	1
◆ Borne By Debtor [DEBT]		
◆ Borne By Creditor [CRED]		
◆ Shared [SHAR]		
◆ Following Service Level [SLEV]		

example of Return Reason Information in pacs.004 v9 which uses externalised codes

▼ Return Reason Information	0	*
▶ Originator	0	1
▼ Reason	0	1
▼ Code	1	1
▶ Proprietary	1	1

Type
 ExternalReturnReason1Code (based on string)
 • minLength: 1
 • maxLength: 4

Definition
 Reason for the return, as an external reason code I

ExternalReturnReason1Code	DT01	InvalidDate
ExternalReturnReason1Code	DT02	ChequeExpired
ExternalReturnReason1Code	ED01	Correspondent
ExternalReturnReason1Code	ED03	BalanceInfoReq
ExternalReturnReason1Code	ED05	SettlementFail
ExternalReturnReason1Code	EMVL	EMVLIabilitySt
ExternalReturnReason1Code	ERIN	ERIOptionNotS
ExternalReturnReason1Code	FF05	InvalidLocalInst
ExternalReturnReason1Code	FOCR	FollowingCanc
ExternalReturnReason1Code	FR01	Fraud

Proprietary Codes may also be available for certain data elements. These are typically inherited from legacy formats and require definitions in user documentation as these are not captured in the baseline ISO 2022 standards

XLSX format is readable in MS Excel



Character Set

All SWIFT ISO MX message elements (fields) which are defined (by data Type) as text are restricted to FIN X Characters:

a-z A-Z 0-9 / - ? : () . , ' + .

Special characters are additionally allowed in:

- All party (agents and non-agents) Name and Address elements.
- The Related Remittance Information element
- The Remittance Information (structured & unstructured) element
- The Email Address where included as part of a Proxy elements
- City of Birth and Province of Birth elements nested in Private Identification

List of special characters:

!#&%*^_`{}~";@[N]\$><

Currencies in the payments should be expressed in ISO Currency Codes only (3-Characters, e.g. EUR)

Translation of any special character:

!#&%*^_`{}~";@[N]\$>< into MT messages will be represented by a **. (Full Stop)**



Point-to-point versus End-to-end



Point-to-point refers to data passed within a message from one party to the next. This data will not necessarily be passed in subsequent messages.

- **For example:** the *Instruction Identification element* contains a reference meaningful to the party sending a message, subsequent messages in a payment transaction chain can expect the *Instruction Identification* to be replaced by a reference meaningful to the party sending that message leg.



End-to-end refers to data passed throughout the transaction life cycle i.e. within a message from one party to the next and continued in subsequent messages.

- **For example:** the *UETR element* contains a Unique End-to-end Transaction Reference in accordance with the UUID version 4 standards. This same reference is used in all messages related to the payment transaction.

Agent Identification



ISO 20022 messages have a number of elements associated with Agents which allow for these Agents to be referenced by a variety of Financial Institution identifiers.

More commonly the ISO 9362 Financial Institution BIC (*BICFI*) is considered the best practice de facto standard for 'many to many' / correspondent banking payments. However other options include:

Clearing System Member Identifiers when accompanied with the *Clearing System Identification*.

LEI (Legal Entity Identifier)

Name and either structured or unstructured *Postal Address*.

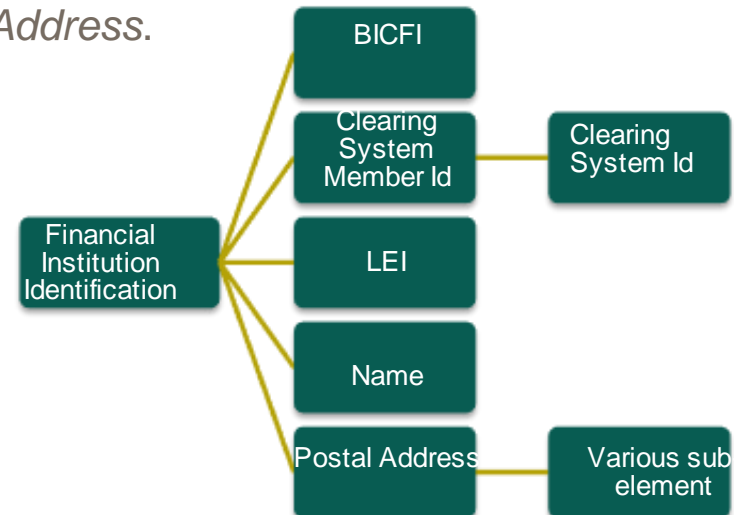

[Back to previous page](#)

Date and DateTime

Two common elements to ISO 20022 messages are **Date** and **DateTime**.

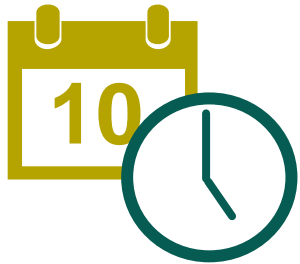

CBPR+ usage guidelines **DateTime** elements mandate the time zone that the time represents as an offset against Universal Time Coordinated (UTC):

Local time with UTC offset **YYYY-MM-DDThh:mm:ss.sss+/-hh:mm**

- For example: **2002-10-10T12:00:00-05:00** (noon/midday on 10 October 2002, Central Daylight Savings Time as well as Eastern Standard Time in the U.S.)
note - milliseconds are optional.



The ISO 20022 **Date** elements allow the date to include an offset. As a data model, shared by other business domains, an offset date can provide great business clarify, such as something expiring at the end of a business date. However, in payments such a date offset provides little business value, whereby should an offset be include with the date, this offset should be ignored.

Clearing System Identification comparison to National Clearing System Code

Country	Code Name	MT Clearing System code	ISO 20022 Clearing System Identification
Australia	Australian Bank State Branch Code (BSB)	AU	AUBSB
Austria	Austrian Bankleitzahl	AT	ATBLZ
Canada	Canadian Payments Association Payment Routing Number	CC	CACPA
China	Bank Branch code used in China	CN	CNAPS
Germany	German Bankleitzahl	BL	DEBLZ
Greece	Hellenic Bank Identification Code	GR	GRBIC
Hong Kong	Hong Kong Bank Code	HK	HKNCC
India	Indian Financial System Code	IN	INFSC
Ireland	Irish National Clearing Code	IE	IENCC
Italy	Italian Domestic Identification Code	IT	ITNCC
Japan	Japan Zengin Clearing Code	JP	JPZGN
New Zealand	New Zealand National Clearing Code	NZ	NZNCC
Poland	Polish National Clearing Code	PL	PLKNR
Portugal	Portuguese National Clearing Code	PT	PTNCC
Russia	Russian Central Bank Identification Code	RU	RUCBC
South Africa	South African National Clearing Code	ZA	ZANCC
Spain	Spanish Domestic Interbanking Code	ES	ESNCC
Switzerland	Swiss Clearing Code (BC Code)	SW	CHBCC
Switzerland	Swiss Clearing Code (SIC Code)	SW	CHSIC
Taiwan	Financial Institution Code	TW	TWNCC
UK	UK Domestic Sort Code	SC	GBDSC
US	CHIPS Participant Identifier	CP	USPID
	United States Routing Number	FW	USABA



For translation rules and comparison purposes this table provides a list of published MT National Clearing System codes again their equivalent ISO 20022 Clearing System Identification in the external code list.

Business Application Header



head.001 Business Application Header – Character Set

Min 0 – Max 1

The head.001 Business Application Header **Character Set** element declares the character set, in addition to Latin, that is contained in the Business Document e.g. the pacs.008.

Ж œ

The **Character Set** element uses the UnicodeChartsCode string to declare an additional character set, for example **Cyrillic** (Unicode range: 0400-04FF).

ⓧ ۞

This allows the party for which the message is addressed **To** to know in advance the additional character set contained within the Business Document. In this way the message can be routed to a specific application to process the Character Set or handled as an exception if the Character Set is not appropriate for that business transaction.



Extending character sets is not intended in CBPR+ from the initial implementation of the service. This element is intended for use once extended character sets are implemented, whereby the string represented in this element can enable any necessary network validations, such as a closed user group for that character set.

head.001 Business Application Header – From

Min 1 – Max 1

The head.001 Business Application Header **From** element identifies the BIC of the party who created the Business Document (e.g. pacs.008). Additional optional information on this party may also be captured within this nested element, where the BIC takes precedence should the information be inconsistent with the BIC.

A choice must be made for the BIC depending on the party it represents.

Financial Institution Identification which identifies a Financial Institution, and may be further complemented with

- **Clearing System Member Identification**
- **LEI**

as an additional identification.



From 

 Organisation Identifier

 Financial Institution Identifier

head.001 Business Application Header – To

Min 1 – Max 1

The head.001 Business Application Header **To** element identifies the BIC of the party who will ultimately process the Business Document (e.g. pacs.008) Additional optional information on this party may also be captured within this nested element, where the BIC takes precedence should the information be inconsistent with the BIC.

A choice must be made for the BIC depending on the party it represents.

Financial Institution Identification which identifies a Financial Institution, and may be further complemented with

- **Clearing System Member Identification**
- **LEI**

as an additional identification.



To 

 Organisation Identifier

 Financial Institution Identifier

head.001 Business Application Header – Business Message Identifier

Min 1 – Max 1

The head.001 Business Application Header **Business Message Identifier** element contains the *Message Identification* captured within the Business Document's Group Header. The content of this element should match the Business Document to avoid incorrect routing by the recipient.

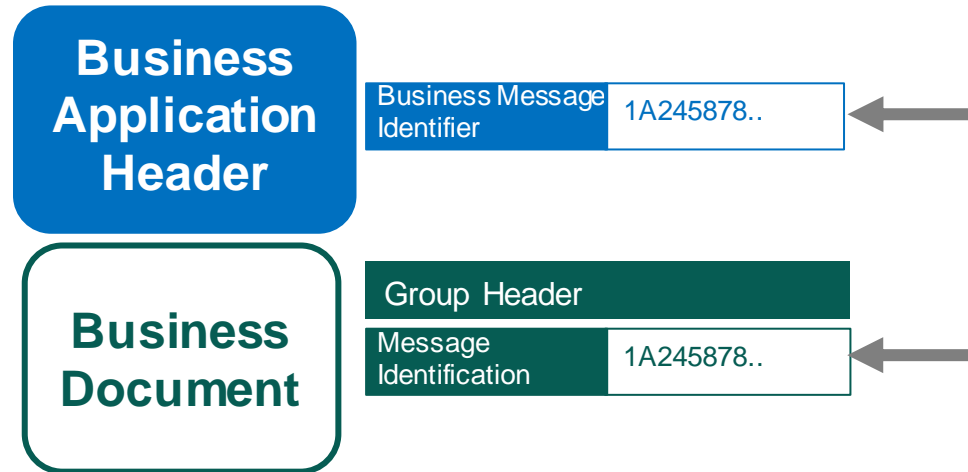

Business Message Identifier



head.001 Business Application Header – Message Definition Identifier

Min 1 – Max 1

The head.001 Business Application Header **Message Definition Identifier** element contains the name of the Business Document. The content of this element should match the Business Document to avoid incorrect routing by the recipient.

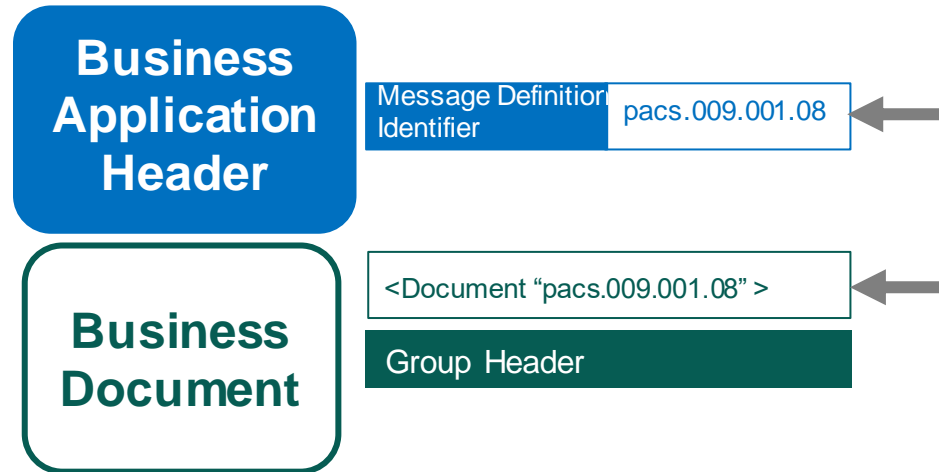

Message Definition Identifier



head.001 Business Application Header – Business Service

Min 1 – Max 1

The head.001 Business Application Header **Business Service** element is used to identify administered services on the SWIFT network. The data represented in this elements is referred to as a **Usage Identifier**. For CBPR+ examples are provided below, these values may be used together with the *Message Definition Identifier* to determine routing rules to specific applications without having to open the business document.

Message Definition Identifier	Business Service	Business Use Case
pac.009.001.08	<i>swift.cbprplus.cov.01</i>	Financial Institution (Cover) Credit Transfer
pac.009.001.08	<i>swift.cbprplus.01</i>	Serial Financial Institution Credit Transfer
pac.008.001.08	<i>swift.cbprplus.stp.01</i>	STP Customer Credit Transfer

The **Business Service** is also intended to be incremented for the same message version, when an updated Usage Guideline is released. For example a new restriction is applied to the pac.009.001.08 Usage Guideline, the **Business Service** *swift.cbprplus.cov.02* and *swift.cbprplus.02* will be used to reflect these new Guidelines and allow network validate.

Note: when a new message (Message Definition Identifier) version is introduced the numeric value for the Business Service is reset.



[Take me to Message Name Identification overview](#)

Business Service

head.001 Business Application Header – Business Service

Message Definition Identifier	Business Service
pain.001.001.09	sw ift.cbprplus.02
pain.002.001.10	sw ift.cbprplus.02
pain.008.001.03	sw ift.cbprplus.01
pacs.002.001.10	sw ift.cbprplus.02
pacs.003.001.08	sw ift.cbprplus.01
pacs.004.001.09	sw ift.cbprplus.02
pacs.008.001.08	sw ift.cbprplus.02
pacs.008.001.08 (STP/STP EU)	sw ift.cbprplus.stp.02
pacs.009.001.08 (advice)	sw ift.cbprplus.adv.02
pacs.009.001.08 (core)	sw ift.cbprplus.02
pacs.009.001.08 (cov)	sw ift.cbprplus.cov.02
pacs.010.001.03	sw ift.cbprplus.02
pacs.010.001.03 (Margin Collection)	sw ift.cbprplus.col.01
camt.029.001.09	sw ift.cbprplus.02
camt.052.001.08	sw ift.cbprplus.02
camt.053.001.08	sw ift.cbprplus.02
camt.054.001.08	sw ift.cbprplus.02
camt.055.001.08	sw ift.cbprplus.01
camt.056.001.08	sw ift.cbprplus.02
camt.057.001.06	sw ift.cbprplus.02

Message Definition Identifier	Business Service
camt.058.001.08	sw ift.cbprplus.01
camt.060.001.05	sw ift.cbprplus.02
camt.107.001.01	sw ift.cbprplus.01
camt.108.001.01	sw ift.cbprplus.01
camt.109.001.01	sw ift.cbprplus.01

The data represented in the Business Service, together with the Message Definition Identifier has a number of roles, in addition to the routing rules referred to on the previous page.

This data value:

- Identifiers explicitly the Usage Guideline within a library of guideline. For example an application may have various pacs.008 libraries within a collection, for which only one of these is appropriate to be used to identify data requirements or perform validation.
- is also populated in the Request Header of the InterAct message in the **Request Sub Type** element which allow the service (FINplus for CBPR+) to apply network validation rules.

head.001 Business Application Header – Market Practice

Min 0 – Max 1

The head.001 Business Application Header **Market Practice** element is used to identify administered services on the SWIFT network.

This element is currently not foreseen to be used by CBPR+.



head.001 Business Application Header – Creation Date

Min 1 – Max 1

The head.001 Business Application Header **Creation Date** captures the date and time which the Business Application Header was created.

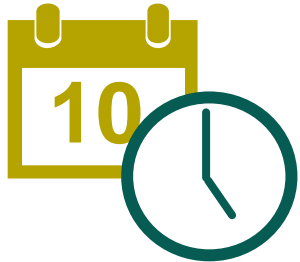

CBPR+ usage guidelines mandate the time zone that the time represents as an offset against Universal Time Coordinated (UTC):

Local time with UTC offset YYYY-MM-DDThh:mm:ss.sss+/-hh:mm

- For example: 2002-10-10T12:00:00-05:00 (noon/midday on 10 October 2002, Central Daylight Savings Time as well as Eastern Standard Time in the U.S.)



All CBPR+ time elements need offset against UTC. Milliseconds are optional.

Creation Date

head.001 Business Application Header – Copy Duplicate

Min 0 – Max 1

The head.001 Business Application Header **Copy Duplicate** indicator is used as a choice to identify scenarios where a message was previously sent.

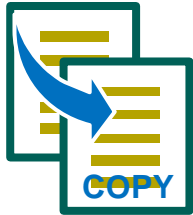

COPY is used to represent a copy of a message being sent to an additional party. This scenario is only associated with camt reporting messages.

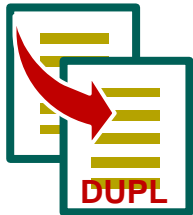

DUPL is used to represent a duplicate of a previously sent camt reporting message. To receive a duplicate payment message, Interact message retrieval should be utilised.



CODU is used to represent a duplicate of a previously sent **COPY** message. This scenario is only associated with camt reporting messages.



Where utilised in the Business Application Header of a camt message the content of this element should match the Copy Duplicate element within the camt message to avoid incorrect routing by the recipient.

Copy Duplicate

head.001 Business Application Header – Possible Duplicate

Min 0 – Max 1

The head.001 Business Application Header **Possible Duplicate** element is used as a flag to indicate that if the party who will ultimately process the Business Document (e.g. pacs.008) received the original, then it should perform necessary actions to avoid processing this Business Message again.



This element is represented by a Yes/No Boolean, whereby **true** represent this is a Possible Duplicate.



It is not necessary to represent **false** (No) the absence of this optional element itself indicates that this is not considered a Possible Duplicate.



The FINplus Technical Header has an element **PDIndicator** (Possible Duplicate Indicator) which uses a Yes/No Boolean. This may be populated by the network interface to identify a message it considers may be a possible duplicate.

Possible Duplicate

head.001 Business Application Header – Priority

Min 0 – Max 1

The head.001 Business Application Header **Priority** element allows a choice of Business Message Priority Code to indicate the priority which may be applied to the business message.

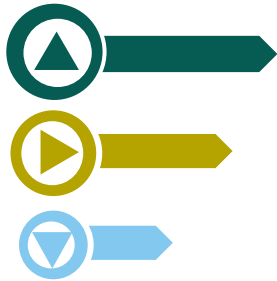

This element must represent the priority code of the business document (instance) which is only applicable for pacs messages. The pacs message priority is captured in the Payment Type Priority/Instruction Priority.

head.001 Business Application Header – Related

Min 0 – Max 1

The head.001 Business Application Header **Related** nested element enables the capture of the Business Application Header from a related Business Document. For example, in a pacs.004 Payment Return the **Related** Business Application Header from the original message can be included. This could allow the receiver to apply specific routing to the message, based on the related information i.e., return of a pacs.009 cov may be routed to different payment engine than a core pacs.009.



The following elements are nested within the Related element. Where used these contain the original data from the related Business Application Header:

From	Min 1 – Max 1
To	Min 1 – Max 1
Business Message Identifier	Min 1 – Max 1
Message Definition Identifier	Min 1 – Max 1
Business Service	Min 0 – Max 1
Creation Date	Min 1 – Max 1
Copy Duplicate	Min 0 – Max 1
Priority	Min 0 – Max 1



Related

Payment Initiation - Messages index

[pain.001 - Interbank Customer Credit Transfer initiation](#)

[pain.002 – Interbank Customer Payment Status Report](#)

[pain.008 – Customer Direct Debit Initiation](#)



pain.001

Interbank Customer Credit Transfer Initiation



High level pain.001 comparison with legacy MT 101



ISO 20022 message element



MT Field Name & (Tag option)

Group Header

- **Message Identification**
- **Initiating Party** – where different from **Debtor**
- **Forwarding Agent**

Payment Information

- **Payment Information Identification**
- **Requested Execution Date**
- **Debtor**
- **Debtor Agent**

Credit Transfer Transaction Information

- **Payment Identification**
- **Amount**
- **Charge Bearer**
- **Creditor Agent**
- **Creditor**

Sequence A – General Information:

- **Sender's Reference** (Field 20)
- **Instructing Party** (Field 50 C or L)

Message **Sender** in a 'relay' scenario

Sequence A – General Information:

- **Customer Specified Reference** (Field 21R)
- **Requested Execution Date** (Field 30)
- **Ordering Customer** (Field 50 F, G or H)*
- **Account Servicing Institution** (Field 52 A or C)*

Sequence B – Transaction Details:

- **Transaction Reference** (Field 21)
- **Currency/Transaction Amount** (Field 32B)
- **Details of Charges** (Field 71A)
- **Account With Institution** (Field 57 A, C or D)
- **Beneficiary** (Field 59 no letter, A or F)

*or in Sequence B – Transaction Detail

pain.001 Interbank Customer Credit Transfer Initiation

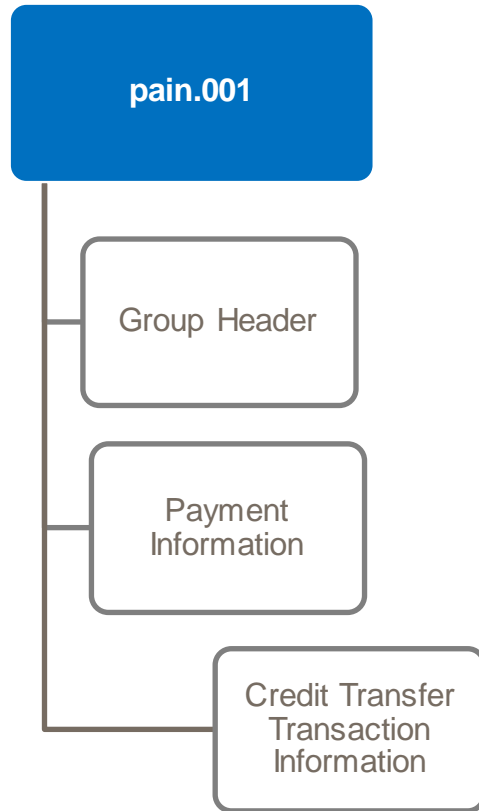

The pain.001 message is composed of three blocks:

- **Group Header** contains a set of characteristics that relates to all individual transaction.
- **Payment Information** contains a set of characteristics that relates to the debit side of the transaction, such as Debtor and Debtor Agent.
- **Credit Transfer Transaction Information** contains, among others, elements related to the credit side of the transaction, such as Creditor and Creditor Agent.



Payment messages in a many-to-many payment are considered as a single transaction.

High Level serial message flow: Payment Initiation “Relay”

pain.001

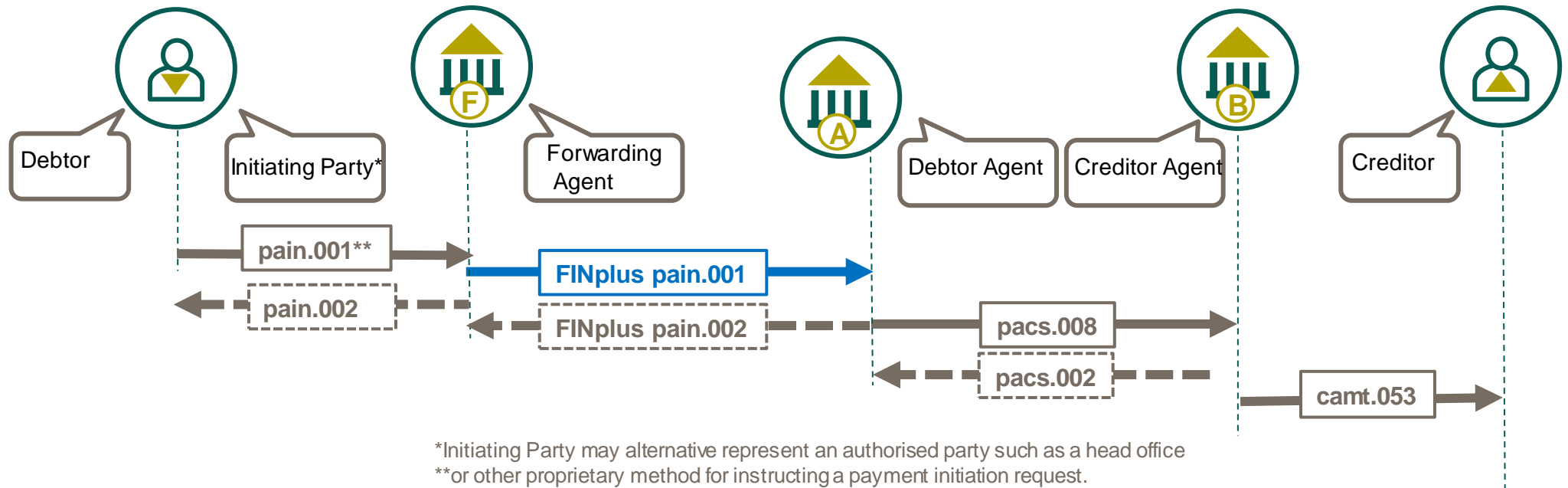

FINplus Customer Credit Transfer Initiation message is sent by the Initiating Party to the Forwarding Agent or the Debtor Agent. It is used to request movement of funds from the debtor account to a creditor. There are three common use cases:

- 1 Relay:** The pain.001 message is sent by the Initiating party (the Debtor or authorised party) to the Forwarding Agent which acts as a concentrating financial institution. It will forward the pain.001 message to the Debtor Agent



A Payment Initiation Rulebook, available in the [Standards Documentation Centre](#), replaces the legacy MT Request for Transfer Service Level Agreement.

Noting in CGI-MP a pain.001 may also be sent by the Initiating Party/Debtor directly to the Debtor Agent which is outside of the scope of CBPR+, however the CBPR+ FINplus pain.001 message is interoperable with CGI-MP.

High Level serial message flow: Payment Initiation “Authorised Party Initiation”

pain.001

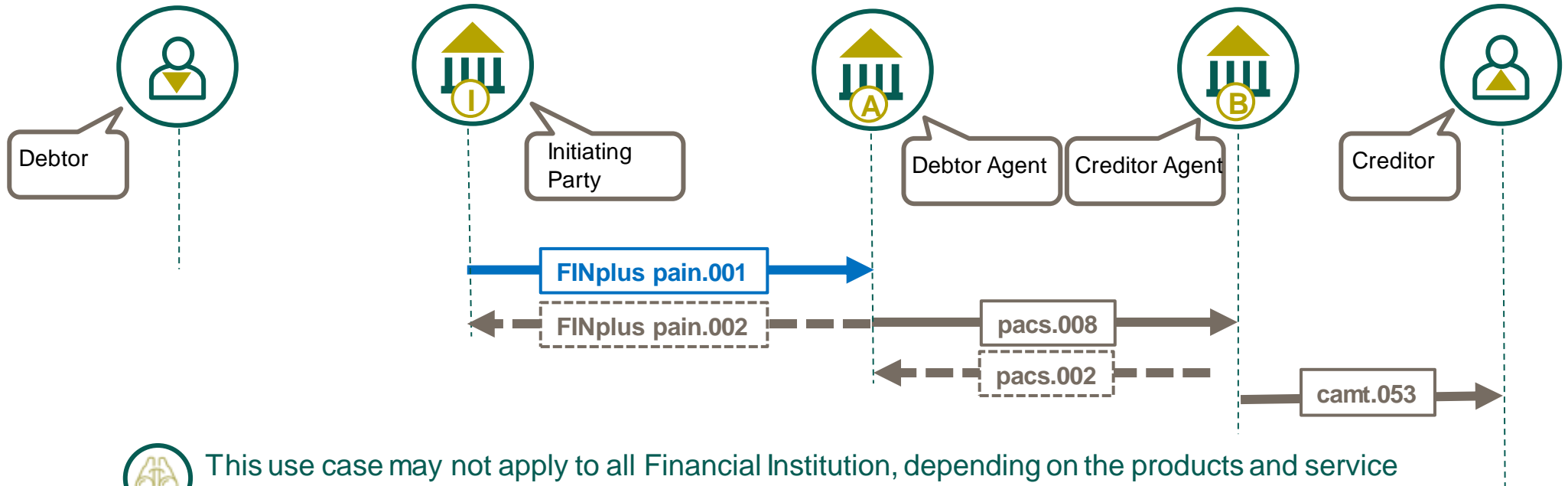

This use case may not apply to all Financial Institution, depending on the products and service provided by that Financial Institution to their customer

FINplus Customer Credit Transfer Initiation message is sent by the Initiating Party to the Forwarding Agent or the Debtor Agent. It is used to request movement of funds from the debtor account to a creditor. There are three common use cases:

- 2 Authorised Party Initiation:** The pain.001 message is sent by the Financial Institution as an Initiating Party to the Debtor Agent to initiate a payment on behalf of the Debtor who is the account holder. For example, a FI Initiates; a liquidity sweep on behalf of a corporate customer or payment from the Debtor account based on Tri-party agreement (agreement from the Debtor with the Debtor Agent to provide authority that the Initiating Party is authorised to execute payments from their account)



Noting in CGI-MP a pain.001 may also be sent by the Initiating Party/Debtor directly to the Debtor Agent which is outside of the scope of CBPR+, however the CBPR+ FINplus pain.001 message is interoperable with CGI-MP.

High Level serial message flow: Payment Initiation “FI Payment Initiation”

pain.001

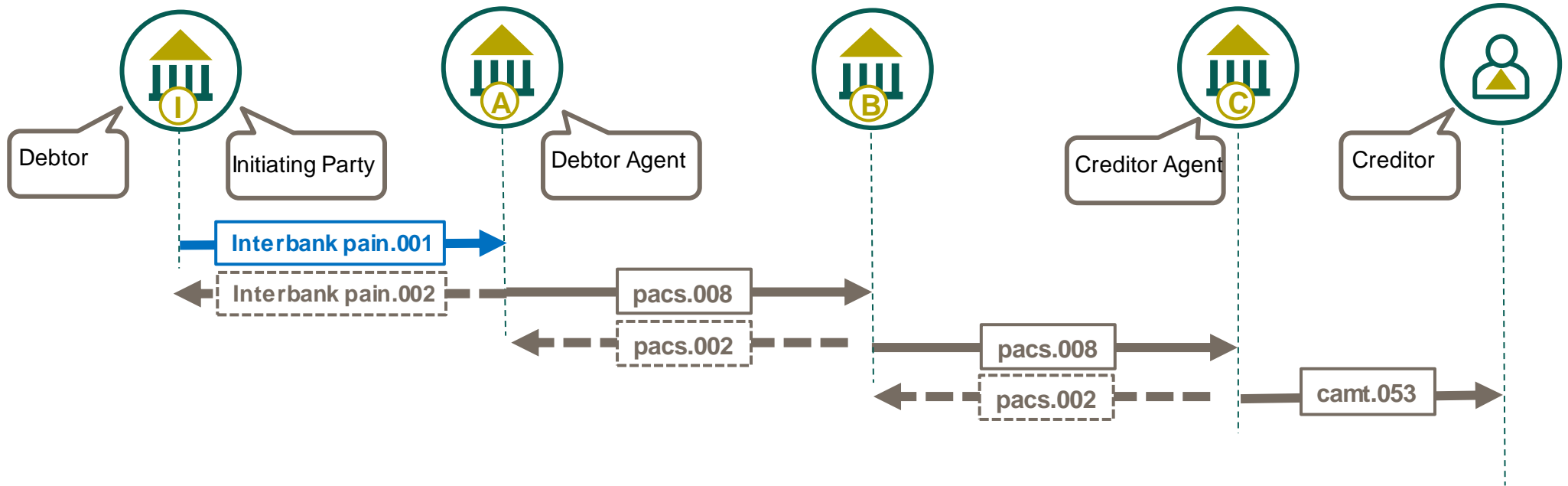

Interbank Customer Credit Transfer Initiation message is sent by the Initiating Party to the Forwarding Agent or the Debtor Agent. It is used to request movement of funds from the debtor account to a creditor. There are three common use cases:

- 3 Financial Institution Payment Initiation** (to non-FI) : The pain.001 message is sent by the Financial Institution as both the Debtor and Initiating Party to initiate a payment from their account with the Debtor Agent to move funds to a non-Financial Institution Creditor

pain.001 Interbank Customer Credit Transfer Initiation – Core Party Descriptions

The following descriptions are defined in the ISO 2022 Standard for core parties participating in an Interbank Customer Credit Transfer Initiation relationship.



Forwarding Agent - “Financial institution that receives the instruction from the initiating party and forwards it to the next agent in the payment chain for execution”. Applicable for pain.001 use case 1 only



Initiating Party – “Party that initiates the payment.” which may be the **Debtor** or a Party acting on behalf of the Debtor e.g., the Agent initiating a liquidity sweep service



Debtor Agent - “Financial institution servicing an account for the debtor.”

Creditor Agent - “Financial institution servicing an account for the creditor.”



Debtor - “Party that owes an amount of money to the (ultimate) creditor.”

Creditor - “Party to which an amount of money is due.”



Noting with the exception of the Forwarding Agent (which is only present in the ‘Relay’ use case) all of these Parties are applicable to each of the use case described in the high-level pain.001 Interbank Customer Credit Transfer Initiation serial message flow.

Group Header



pain.001 Interbank Customer Credit Transfer Initiation – Message Identification



Min 1 – Max 1

Each ISO20022 payment message has a **Message Identification** element, located in the Group Header. This **35 character** identifier is a point-to-point reference used to unambiguously identify the message.

For the Payment Initiation (pain) messages the *Message Identification* has no exact equivalent in the legacy MT payment message. However, the Sender's Reference (Field 20) could be considered as a similar comparison where a pain message contains a single Transaction.



Each transaction's *Credit Transfer Transaction Information* contains a variety of nested *Payment Identification* elements to capture reference related to the individual transaction such as a UETR (Unique End-to-end Transaction Reference).



For a relay scenario, Forwarding Agent should respect the Message ID provided by the Initiating Party (Debtor or authorized third party) of the pain.001.

Group Header ➤ Message Identification



pain.001 Interbank Customer Credit Transfer Initiation – Creation Date Time

Min 1 – Max 1

The pain.001 message **Creation Date Time** captures the date and time which the message was created.

It is defined by **ISO Date Time** with mandatory date and time components expressed in the following formats:

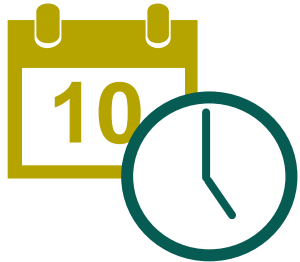

1. Universal Time Coordinated (UTC) time **YYYY-MM-DDThh:mm:ss.sssZ**
2. Local time with UTC offset **YYYY-MM-DDThh:mm:ss.sss+/-hh:mm**
3. Local time format **YYYY-MM-DDThh:mm:ss.sss**



Unlike other CBPR+ messages, the interbank pain.001 message is more flexible in defining the date and time elements. The most recommended representation is Local time with UTC offset which was mandated by CBPR+ (2nd option). Otherwise use UTC time (1st option). Decimal fractions of seconds with 3 digits. Milliseconds are optional.

pain.001 Interbank Customer Credit Transfer Initiation – Authorisation

Min 0 – Max 2

The pain.001 message **Authorisation** allows the Initiating Party to specify if a file requires either File Level or Transaction Level approval by additional security provisions, such as digital signature or user key. The *Authorisation* uses an embedded code set or free text form. It has no exact equivalent in the legacy MT payment message, however, the Authorisation (Field 25) could be considered as a similar comparison.

Code	Description	Description
ILEV	Instruction Level Authorisation	File requires all customer transactions to be authorised or approved.
FDET	File Level Authorisation Details	Additional file level approval, with the ability to view both the payment information block and supporting transaction detail.
FSUM	File Level Authorisation Summary	Additional file level approval, with the ability to view only the payment information block.
AUTH	Pre Authorised File	File has been pre-authorised or approved within the originating customer environment and no further approval is required.



For single transactions in the CBPR+ usage guidelines, the most applicable code will be ILEV for Instruction Level Authorisation. The use of Authorisation is only allowed when bilaterally agreed.

Group Header ➤ Authorisation



pain.001 Interbank Customer Credit Transfer Initiation – Number of Transactions

Min 1 – Max 1

The pain.001 message ***Number of Transactions*** captures the number of individual transaction contained within the message.



The number of transactions in CBPR+ payment usage guidelines is fixed to 1.



Single transactions in the CBPR+ payment usage guidelines enable a transaction to be managed and unlocks highly automated, frictionless, instant payments, supporting the next generation of innovation.

Group Header ➤ *Number of Transactions*

pain.001 Interbank Customer Credit Transfer Initiation – Initiating Party

Min 1 – Max 1

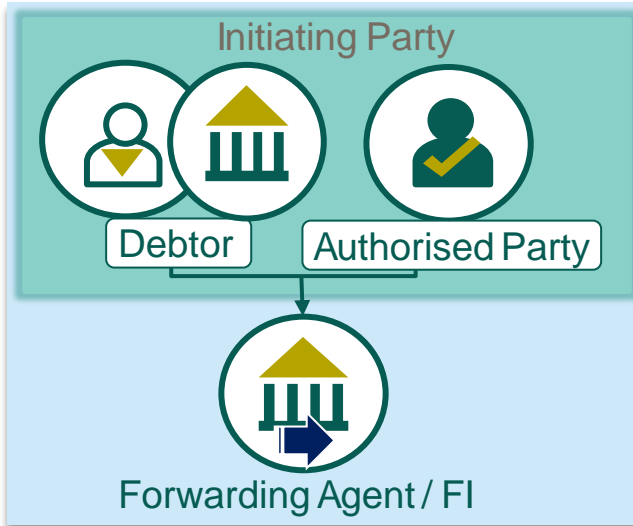

The **Initiating Party** can either be the **Debtor** or an Authorised Party who initiates payment transactions on behalf of the **Debtor**. The Initiating Party can be, for example, the Head Office which has the authority to debit the account of its subsidiary. In the centralization model, the **Initiating Party** can also be a payment factory or shared service center or third-party agent, which has authority to send the message on behalf of the **Debtor**.

There are three common use cases in the context of interbank pain.001 message:

1. **Relay**: The **Initiating Party**, which is either the **Debtor** themselves or authorised party, sends the pain.001 message to the **Forwarding Agent** which acts as a concentrating financial institution. It will forward the pain.001 message to the **Debtor Agent**. This is commonly known as a relay scenario. Whereby the Forwarding Agent is performing a technical role in the payment transaction, they would not be represented in the payment, clearing and settlement message.
2. **Authorised Party**: The **Initiating Party** is the **Financial Institution** which has the authority to send the pain.001 message on behalf of the **Debtor**, e.g., multi-bank liquidity sweeps.
3. **Financial Institution Payment Initiation**: The **Initiating Party** is the **Financial Institution** which is the **Debtor** who initiate a payment from their account to move funds to a non-Financial Institution Creditor



For the second and the third use case, BIC of the Initiating Party is required.



pain.001 Interbank Customer Credit Transfer Initiation – Initiating Party

The **Initiating Party** can either be the **Debtor** or an authorised party, such as Financial Institution, in the context of interbank pain.001. Sub elements describe the **Initiating Party** in greater detail.

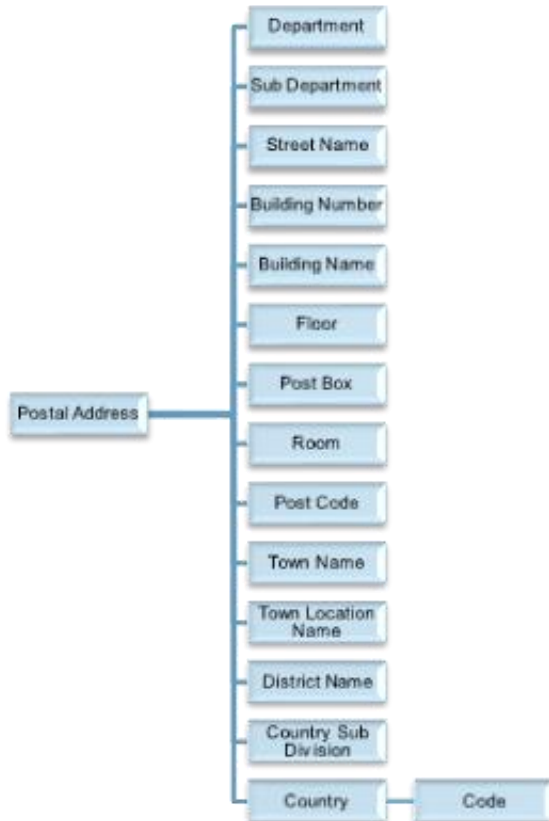

Nested element capturing **structured** Postal Address including at least Town Name and Country if used.

Nested element capturing the various types of identifiers, e.g., **BIC**, LEI etc. **BIC** is mandatory for an Authorised Party initiation and FI payment initiation.

Optional element to capture the Initiating Party's ISO country code of residence

Mandatory **Name** where Postal Address is provided.

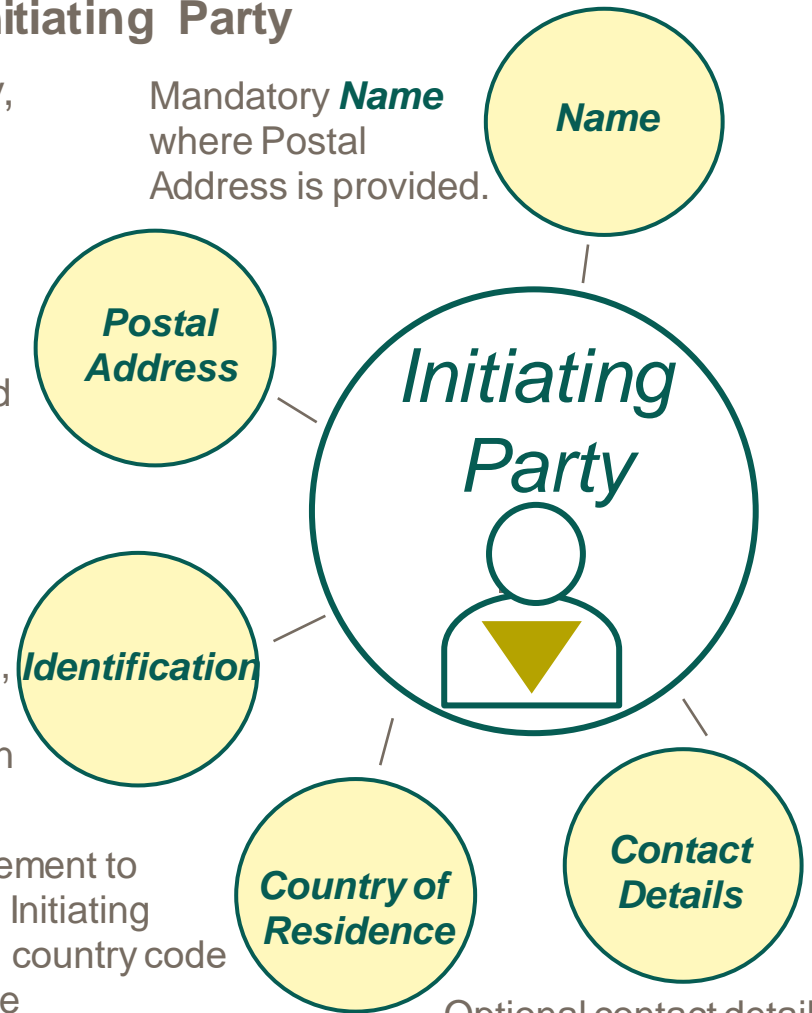

Optional contact details



pain.001 Interbank Customer Credit Transfer Initiation – Forwarding Agent



Min 0 – Max 1

The **Forwarding Agent** is mandatory in a relay scenario whereby the *Initiating Party* (the *Debtor* or authorised third party) has to provide **Business Identifier Code** (BIC FI) of the *Forwarding Agent* in the original pain.001 message. The Forwarding Agent acts as a concentrating financial institution and forwards the pain.001 message to the *Debtor Agent* for execution.

Other options to identify the **Forwarding Agent** include:

- Clearing System Member ID
- LEI (Legal Entity Identifier)

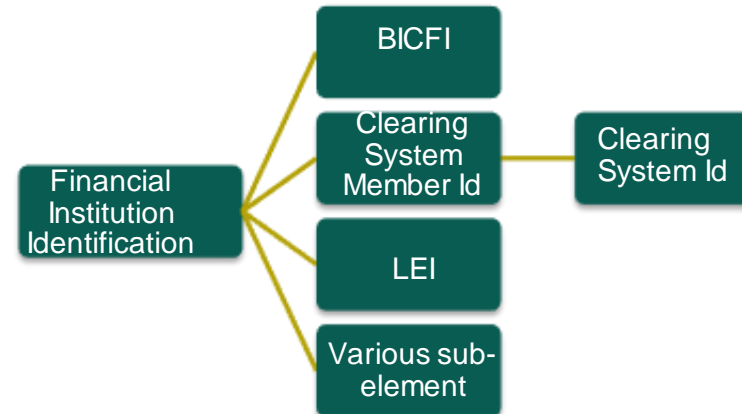

For the use cases of Authorised Party initiation and FI payment initiation, Forwarding Agent is not required.

Group Header ➤ Forwarding Agent

Payment Information



Postal Address – Structured versus Unstructured.

The CBPR+ pain.001 Interbank Usage Guideline aligns to the Usage Guideline of CGI-MP, to remain interoperable. It is important to recognise that the CGI Postal Address allows the Postal Address information to be captured as both structured and unstructured (address line) data, of which the Country Code within the Postal Address is mandatory.

As a payment initiation could instruct various types of Payment Methods settled across various Clearing Methods, it should also be recognized that the Usage Guideline specification of those instructions need to be adhered to, which may need some enrichment or repair of the data from the payment initiation message.

Postal Address is a good example of such data enrichment or repair, where many domestic payment methods exclusively support unstructured postal addresses. Likewise, CBPR+ and HVPS+ payments consider structured and unstructured postal addresses to be mutually exclusive. i.e., only one or the other may be used.

CGI-MP payment Initiation/
CBPR+ payment initiation interbank

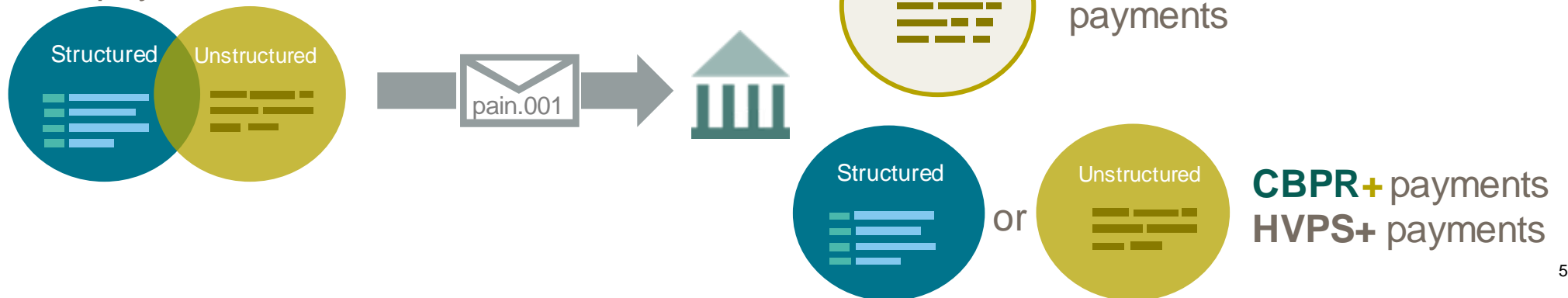

pain.001 Interbank Customer Credit Transfer Initiation – Payment Information Identification

Min 1 – Max 1

The Interbank Customer Credit Transfer Initiation **Payment Information Identification** provides a mandatory element to identify the payment initiation.



This 35 character identifier is a point-to-point reference used to unambiguously identify the payment information group within the message. It is also known as a batch reference number if the message contains multiple transactions.



For single transactions in the CBPR+ usage guidelines, the value in Payment Information Identification is the same as the Message Identification of the Group Header.

Payment Information ➤ Payment Information Identification



pain.001 Interbank Customer Credit Transfer Initiation – Payment Method

Min 1 – Max 1

The pain.001 message **Payment Method** specifies the means of payment that will be used to move the amount of money. One of the following payment method codes must be used:

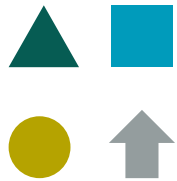

Code	Name	Definition
CHK	Cheque	Written order to a bank to pay a certain amount of money from one person to another person.
TRF	Credit Transfer	Transfer of an amount of money in the books of the account servicer.

pain.001 Interbank Customer Credit Transfer Initiation – Payment Type Information

Min 0 – Max 1

The pain message **Payment Type Information** provides a set of optional elements where the payment type can be described.

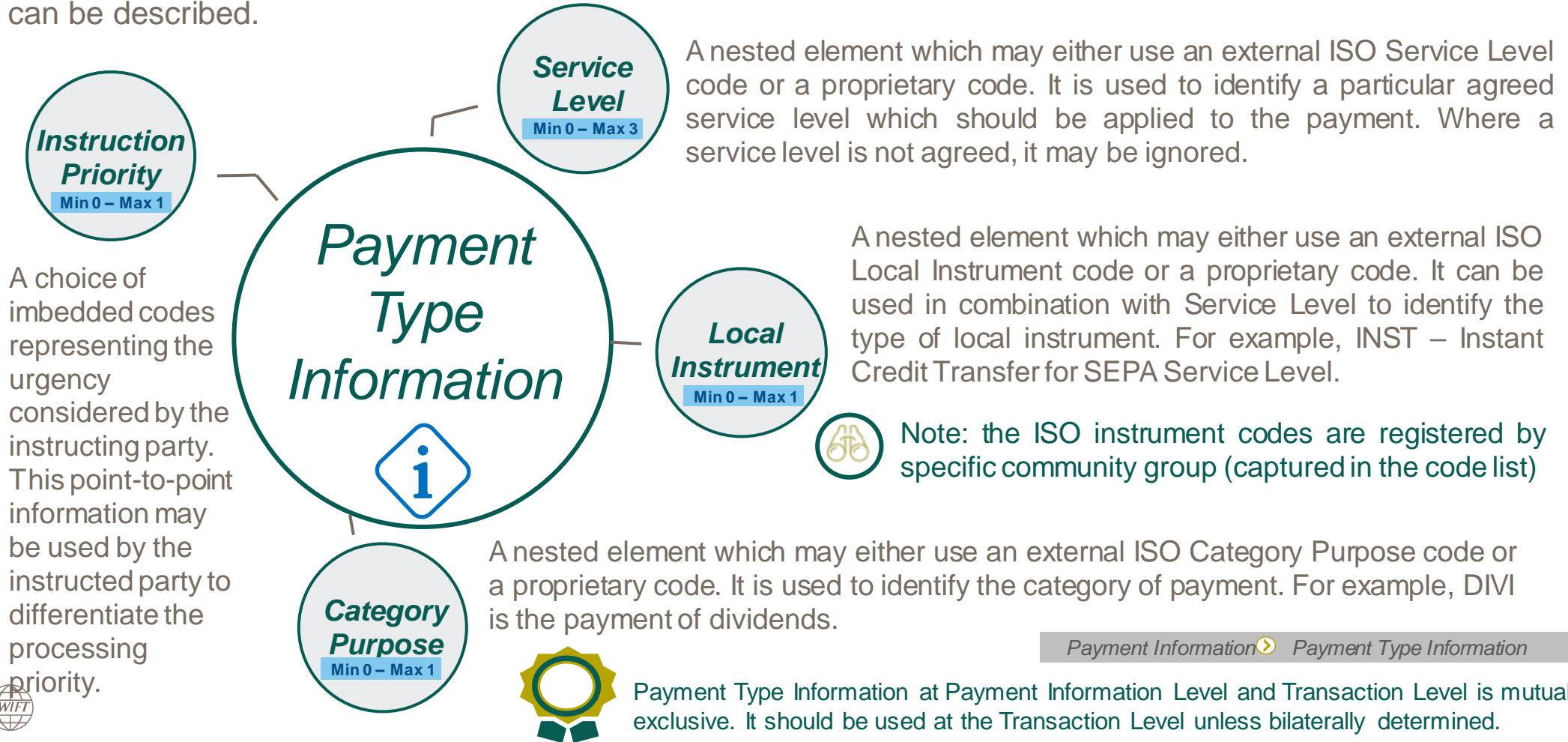

Payment Information → Payment Type Information

Payment Type Information at Payment Information Level and Transaction Level is mutually exclusive. It should be used at the Transaction Level unless bilaterally determined.

pain.001 Interbank Customer Credit Transfer Initiation – Requested Execution Date

Min 1 – Max 1

The pain.001 message mandatory **Requested Execution Date** element, captures the date and time at which the initiating party requests the clearing agent to process the payment.

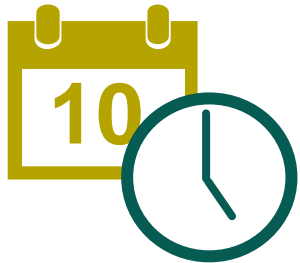

It is the date on which the debtor's account is debited. If payment by cheque, the date when the cheque must be generated by the bank. It is defined by either **ISO Date** expressed in the *YYYY-MM-DD format* or **ISO Date Time** below:

1. Universal Time Coordinated (UTC) time **YYYY-MM-DDThh:mm:ss.sssZ**
2. Local time with UTC offset **YYYY-MM-DDThh:mm:ss.sss+/-hh:mm**
3. Local time format **YYYY-MM-DDThh:mm:ss.sss**



Unlike other CBPR+ messages, the interbank pain.001 message is more flexible in defining the date and time elements. The most recommended representation is Local time with UTC offset which was mandated by CBPR+ (2nd option). Otherwise use UTC time (1st option). Decimal fractions of seconds with 3 digits. Milliseconds are optional.

pain.001 Interbank Customer Credit Transfer Initiation – Pooling Adjustment Date

Min 0 – Max 1

The pain.001 message optional **Pooling Adjustment Date** element, is used for the correction of the value date of a cash pool movement that has been posted with a different value date.

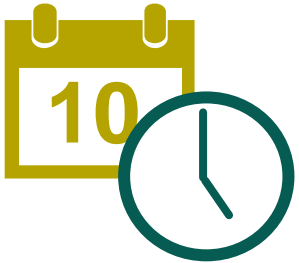

It is defined by **ISO Date** expressed in the *YYYY-MM-DD format*



This element is not widely used in the payment industry. For the use case of interbank, it is even less likely to be utilized.

pain.001 Interbank Customer Credit Transfer Initiation – Debtor

The ISO 2022 pain messages describes the party whose account is debited for a transaction as the **Debtor**. Min 1 – Max 1
The *Debtor* sub elements describe the *Debtor* in greater detail.

Mandatory **Name** (where a BIC identifier is not provided) by which the party is known

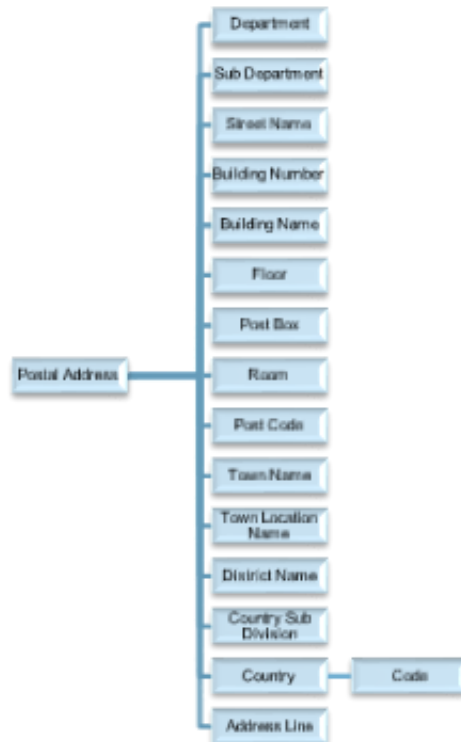

Nested element capturing either structured or unstructured *Debtor* address details.

 Note: Structured address is strongly recommended with mandatory Town Name and Country

Nested element capturing the various types of identifiers for the party e.g. BIC, LEI etc.

Optional element to capture the *Debtor's* ISO country code of residence

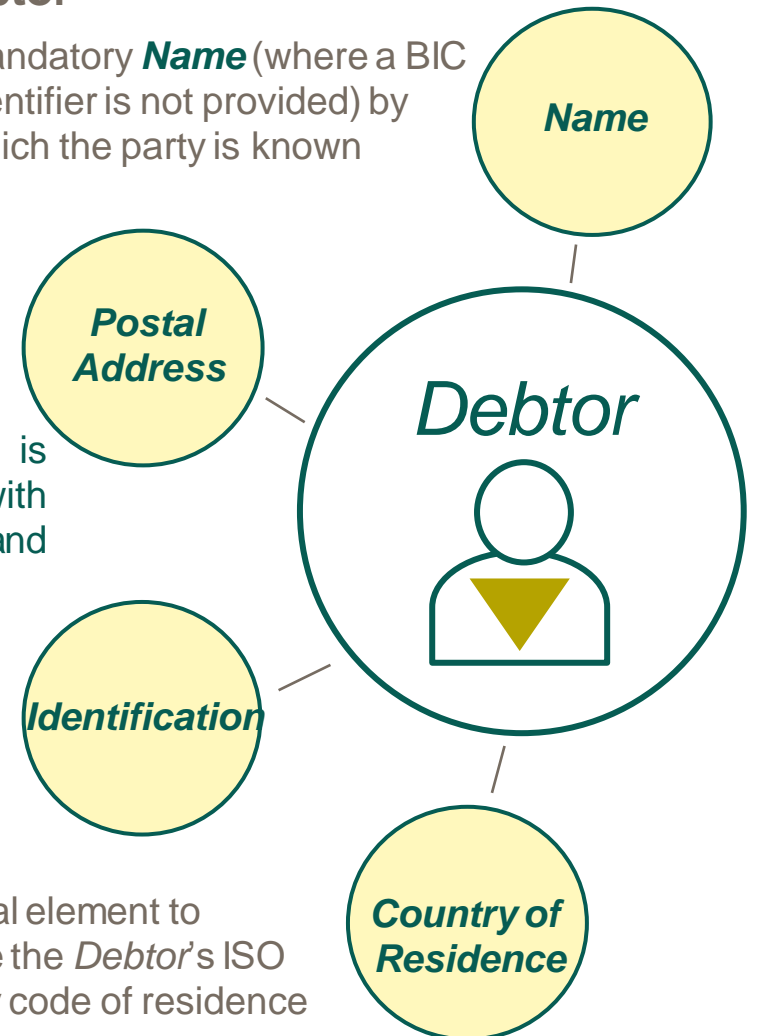

In order to process the pain.001 interbank into a CBPR+ payment, CBPR+ requires either structured or unstructured postal address.



[Take me to an explanation of CGI Postal Address](#)

pain.001 Interbank Customer Credit Transfer Initiation – Debtor Account

Min 1 – Max 1

The pain.001 **Debtor Account** is used to capture the account information for which debit entry will be made as a result of the transaction, which will be also reflected in their account Statement.

The **Debtor Account** uses a variety of nested elements to capture information related to the account.



Min 1 – Max 1 Identification identifies the account maintained at the Debtor Agent (Account Servicing Institution)

Min 0 – Max 1 Type uses the external Cash Account Type code list to identify the type of account

Min 0 – Max 1 Currency identifies the currency of the account, recommended.

Min 0 – Max 1 Name identifies the name of the account as assigned by the Debtor Agent (Account Servicing Institution)

Min 0 – Max 1 Proxy captures an alternative identification of the account number such as an email address. This element has further nested **Type** which is a choice of external code list or proprietary code and **Identification** which are both mandatory where the Proxy element is used.



Indication of Currency of the Debtor Account is recommended in case of multi-currency accounts whereby a single account number is allocated to the Debtor Account.



pain.001 Interbank Customer Credit Transfer Initiation – Debtor Agent

Min 1 – Max 1

The **Debtor Agent** is a static role in the pain.001 Customer Credit Transfer Initiation. This agent maintains a relationship with their customers, the **Debtor**.



Note: Although the **Debtor Agent**, **Creditor Agent**, **Debtor** and **Creditor** all maintain static roles in the pain messages, the description of these parties change in the reporting messages (camt) where the Debtor Agent and Creditor Agent become the Statement Account Servicer and the Debtor and Creditor become the Statement Account Owner. This will be explored further in the camt Cash Management Reporting section.



For Agent Identification, BIC is preferred, alternatively Clearing Member ID together with Name and Address may be provided.

pain.001 Interbank Customer Credit Transfer Initiation – Debtor Agent Account

Min 0 – Max 1

The pain.001 **Debtor Agent Account** is used to capture the account information related to the Debtor Agent.

The **Debtor Agent Account** uses a variety of nested elements to capture information related to the account.



Min 1 – Max 1

Identification identifies the account maintained at the Account Servicing Institution

Min 0 – Max 1

Type uses the external Cash Account Type code list to identify the type of account

Min 0 – Max 1

Currency identifies the currency of the account

Min 0 – Max 1

Name identifies the name of the account as assigned by the Account Servicing Institution

Min 0 – Max 1

Proxy captures an alternative identification of the account number such as an email address. This element has further nested **Type** which is a choice of external code list or proprietary code and **Identification** which are both mandatory where the Proxy element is used.



Debtor Agent and Creditor Agent are Financial Institutions, therefore the nested elements **Name** and **Proxy** are unlikely to be used.

pain.001 Interbank Customer Credit Transfer Initiation – Instruction For Debtor Agent

Min 0 – Max 1

The ***Instruction for Debtor Agent*** element within the pain.001 message optionally provides information related to the processing of the payment.



The ***Instruction for Debtor Agent*** element offers a maximum of 140 characters to further information related to the processing of the payment instruction, that may need to be acted upon by the *Debtor Agent*, depending on bilateral agreement.

pain.001 Interbank Customer Credit Transfer Initiation – Ultimate Debtor

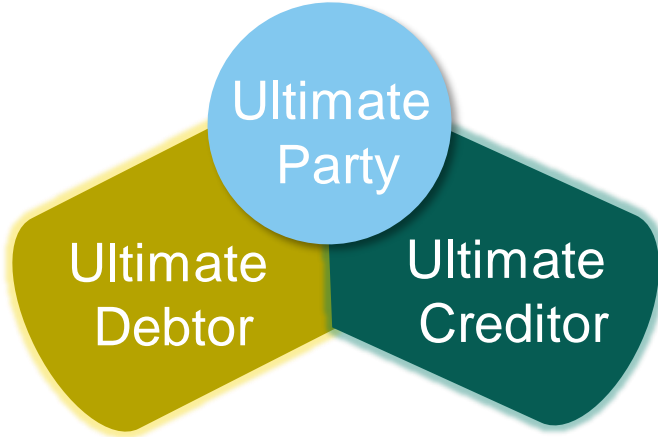

The pain.001 message introduces **Ultimate Debtor** and **Ultimate Creditor**. The **Ultimate Debtor** element should not be confused with an **Initiating Party** who may send a payment initiation request on behalf of the **Debtor**, for example, Payment Factory.

CBPR+ premise is that an **Ultimate Debtor** has no financial regulated direct account relationship with the corresponding Debtor. Likewise, an **Ultimate Creditor** has no financial regulated account relationship with the corresponding Creditor.

The **Ultimate Debtor** and **Ultimate Creditor** can be identified by a combination of Name and structured address or Organisation ID (e.g., BIC, LEI), Private ID and Country Of Residence.



Ultimate Debtor exists at the Payment Information Level and Transaction Level. Since CBPR+ interbank pain.001 is restricted to single transaction, Ultimate Debtor should be used at the Transaction Level unless bilaterally determined.

pain.001 Interbank Customer Credit Transfer Initiation – Charge Bearer

Min 0 – Max 1

The **Charge Bearer** element exists at the Payment Information level and Transaction level. It uses an embedded code to specify which party/parties would bear any charges associated with processing the payment transaction. This element is comparable with MT Field 71A ‘Details of Charges’

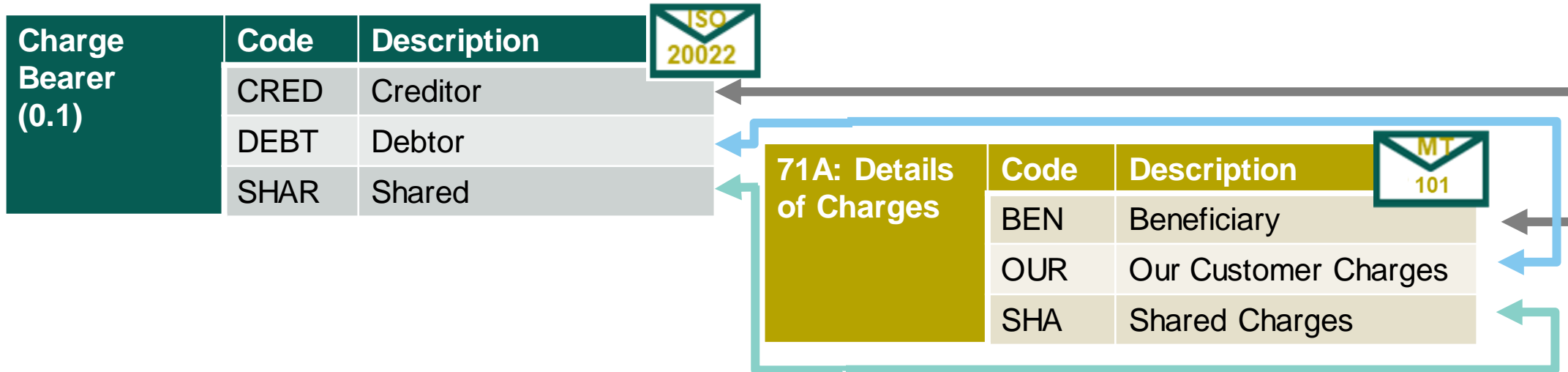

Charge Bearer at the Payment Information Level and the Transaction Level is mutually exclusive. It should be used at the Transaction Level unless bilaterally determined.

pain.001 Interbank Customer Credit Transfer Initiation – Charges Account

Min 0 – Max 1

The pain.001 optional **Charges Account** element, which is used to process charges associated with a transaction.

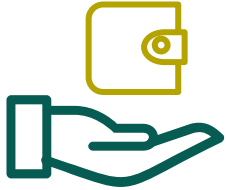

Charges account should be used when charges have to be booked to an account different from the account identified in debtor's account.



This element is not widely used in the payment industry.

pain.001 Interbank Customer Credit Transfer Initiation – Charges Account Agent

Min 0 – Max 1

The pain.001 optional **Charges Account Agent** element, which is used to specify the agent that services a charges account.



Charges account agent should only be used when the charges account agent is different from the debtor agent.



This element is not widely used in the payment industry. It should also be noted that the ChargesAccountAgentRule inherited from the base message should be ignored as the optional Branch of DebtorAgent is removed from this Usage Guideline.

Credit Transfer Transaction Information



pain.001 Interbank Customer Credit Transfer Initiation - Payment Identification

Min 1 – Max 1

The pain.001 message contains **Payment Identification** which provides a set of elements to identify the payment of which several are mandatory elements.

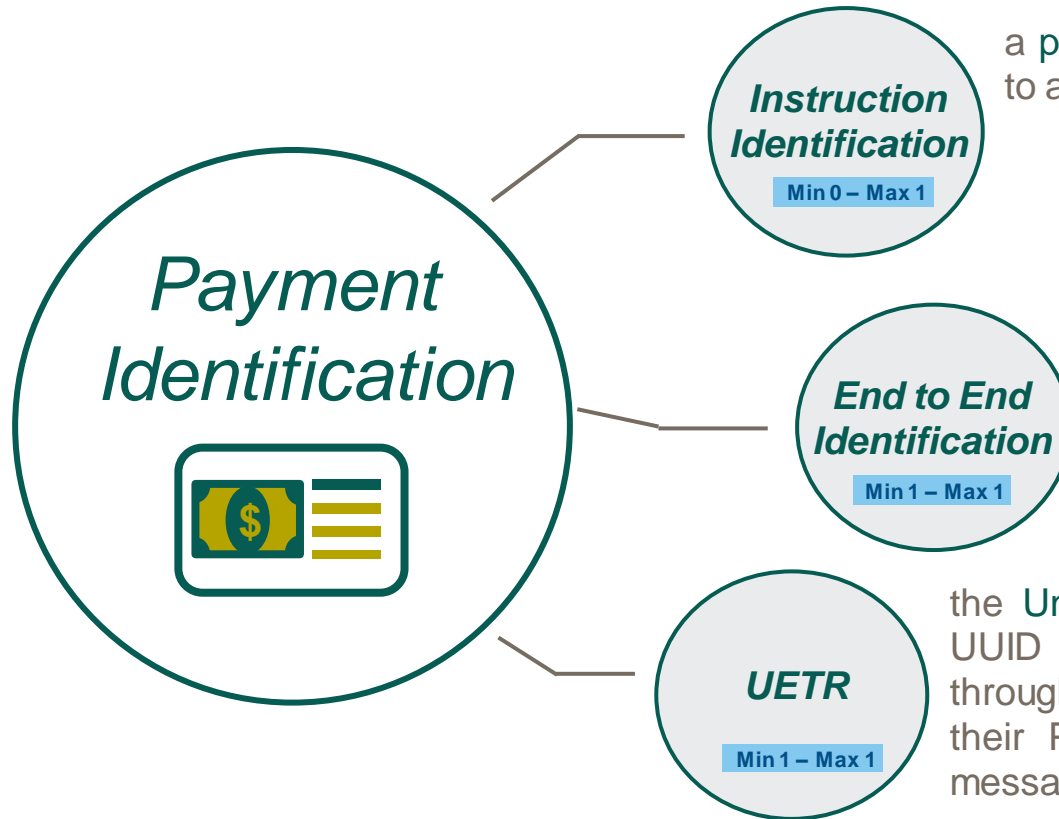

a **point-to-point reference** of 35 characters long will be returned to account statements if provided by the initiating party.



Note: Instruction Id is mandatory in other CBPR+ messages as it maps directly with the mandatory Sender's Reference (Field 20) of the legacy MT payment messages.

an **end-to-end reference** provided by the *Debtor* which must be passed unchanged throughout the payment and reported to the Creditor.



note: if the Debtor has not provide an end-to-end identifier, the *Debtor Agent* may populate "NOTPROVIDED" to comply the mandatory need of this element.

the **Unique End-to-end Transaction Reference** created using the UUID v4 standard. This reference must be passed unchanged throughout the payment, it may also be created by the Debtor within their Payment Initiation request, and also included in reporting messages.

Credit Transfer Transaction Information

Payment Identification

pain.001 Interbank Customer Credit Transfer Initiation – Payment Type Information

Min 0 – Max 1

The pain.001 **Payment Type Information** provides a set of optional elements where the payment type can be described.

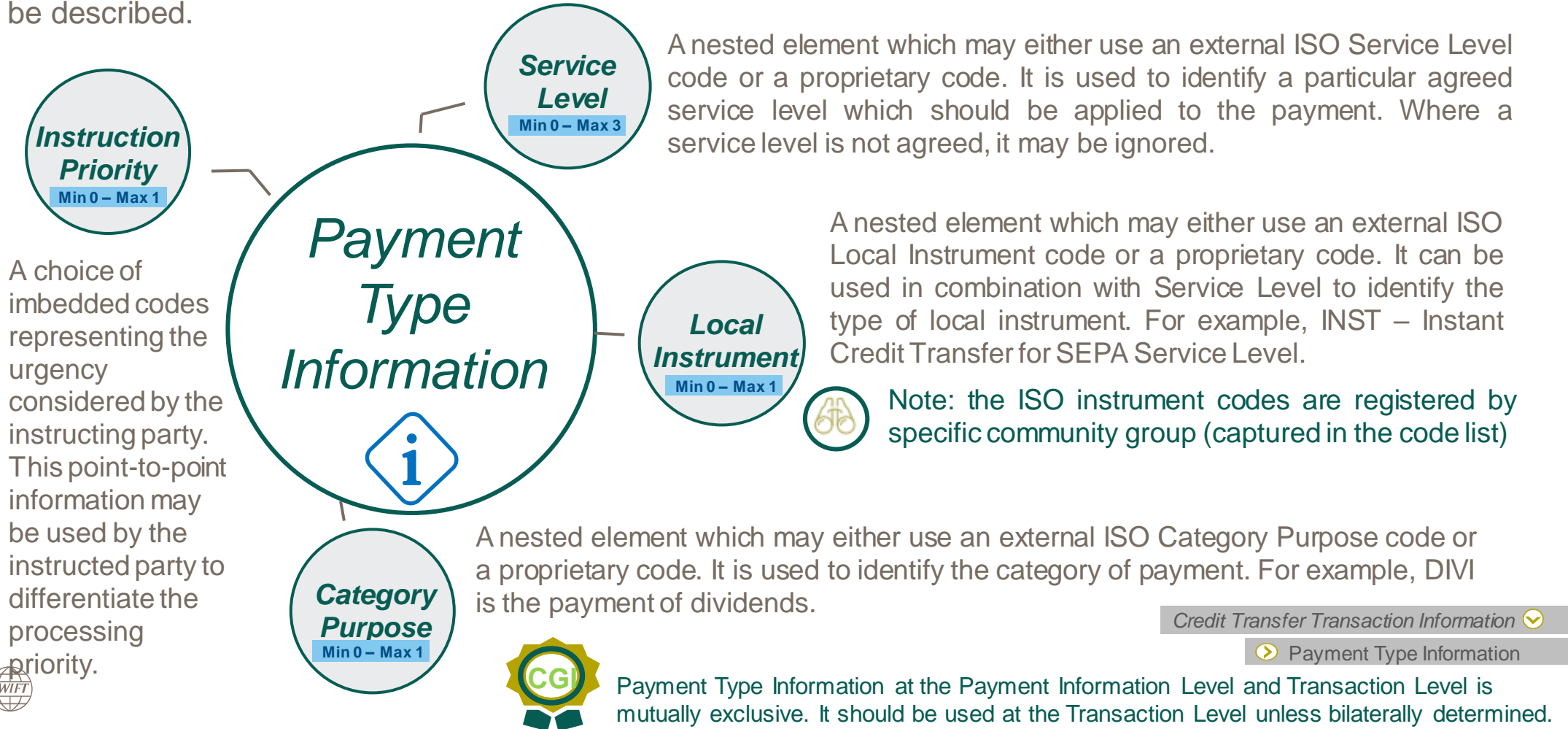

Credit Transfer Transaction Information

Payment Type Information



pain.001 Interbank Customer Credit Transfer Initiation – Currency and Amount

Min 1 – Max 1

The pain.001 nested **Amount** element has a choice of either **Instructed Amount** or **Equivalent Amount** to capture the amount and currency of the Customer Credit Transfer Initiation.



Instructed Amount

The **Instructed Amount** captures currency and amount of money to be moved between the Debtor and Creditor, before deduction of charges, expressed in the currency as ordered by the initiating party. This amount has to be transported unchanged through the transaction chain. This element is comparable with the legacy Field 33B.

Equivalent Amount

The **Equivalent Amount** nested element captures currency and **Amount** of money to be moved between the Debtor and Creditor, before deduction of charges, and is expressed in the currency of the Debtor's account. The **Currency Of Transfer** element capture the equivalent currency to be transferred which the first agent will convert the credit transfer into.

Credit Transfer Transaction Information > Currency and Amount <=>

> Instructed Amount

> Equivalent Amount



pain.001 Interbank Customer Credit Transfer Initiation – Exchange Rate Information

Min 0 – Max 1

The pain.001 **Exchange Rate Information** element provides details on the currency exchange rate and contract.

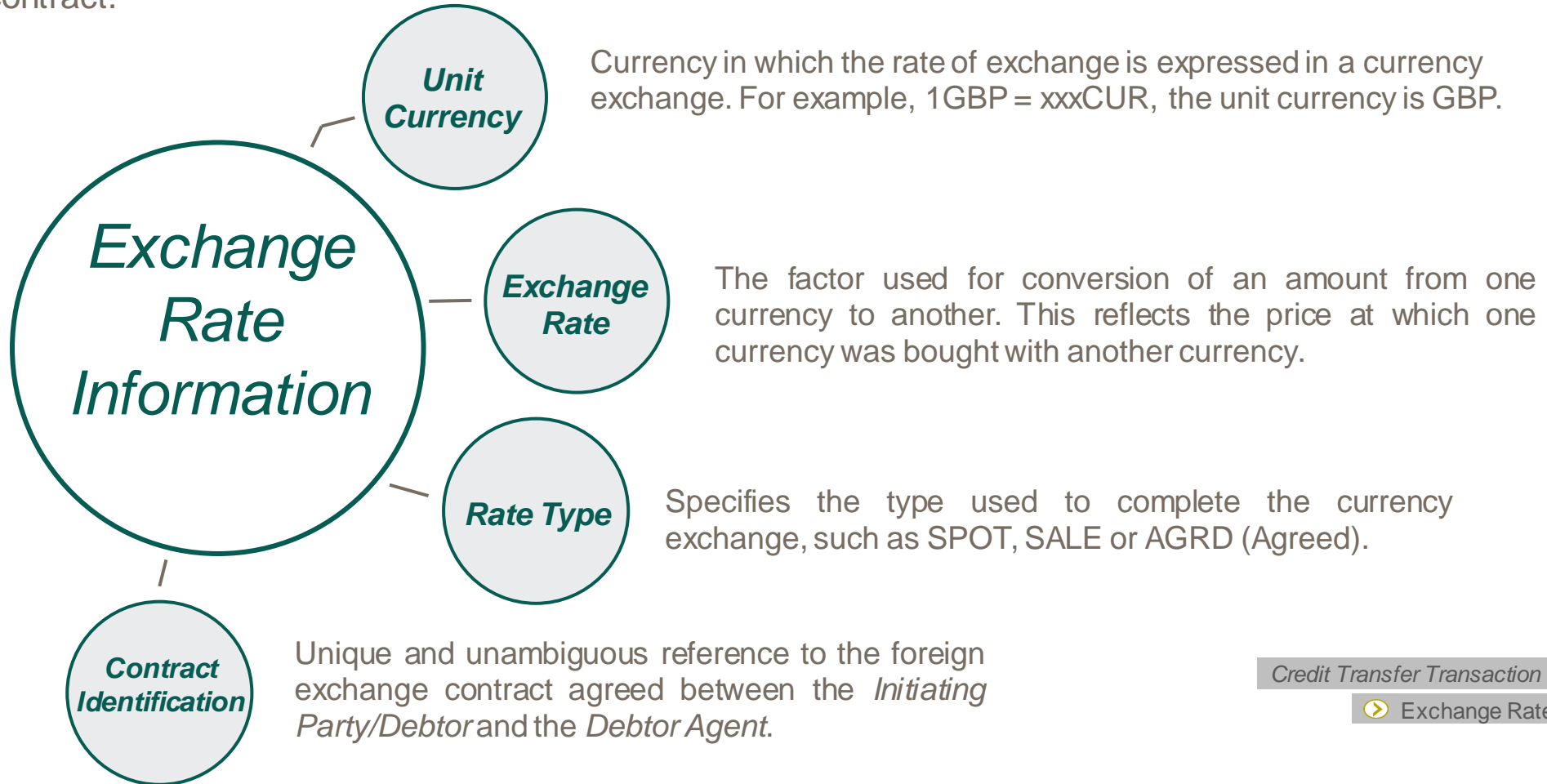

Credit Transfer Transaction Information

Exchange Rate Information



pain.001 Interbank Customer Credit Transfer Initiation – Charge Bearer

Min 0 – Max 1

The **Charge Bearer** element exists at the Payment Information level and Transaction level. It uses an embedded code to specify which party/parties would bear any charges associated with processing the payment transaction. This element is comparable with MT Field 71A ‘Details of Charges’

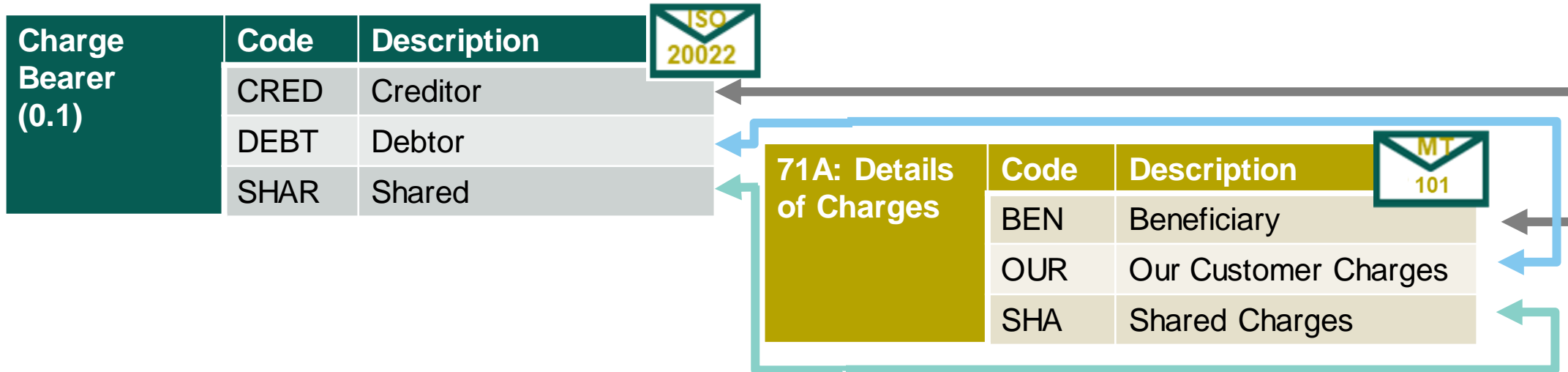

Charge Bearer at the Payment Information Level and the Transaction Level is mutually exclusive. It should be used at the Transaction Level unless bilaterally determined.

Credit Transfer Transaction Information

Charge Bearer



pain.001 Interbank Customer Credit Transfer Initiation – Cheque Instruction

Min 0 – Max 1

The **Cheque Instruction** information block contains a set of elements needed to issue a cheque. The following types of cheques are commonly used in the market:

Cheque Type	Code	Description
Bank Cheque	BCHQ	Cheque drawn on the account of the debtor's financial institution, which is debited on the debtor's account when the cheque is issued. These cheques are printed by the debtor's financial institution and payment is guaranteed by the financial institution. Synonym is 'cashier's cheque'.
Customer Cheque	CCHQ	Cheque drawn on the account of the debtor and debited on the debtor's account when the cheque is cashed. Synonym is 'corporate cheque'.
Draft	DRFT	A guaranteed bank cheque with a future value date (do not pay before), which in commercial terms is a 'negotiable instrument': the beneficiary can receive early payment from any bank under subtraction of a discount. The ordering customer's account is debited on value date.



The **Delivery Method** element specifies the method to be used in delivering the cheque by the *Debtor Agent*. For example, a code CRCD is used to courier the cheque to the *Creditor*.

Credit Transfer Transaction Information 

 Cheque Instruction

pain.001 Interbank Customer Credit Transfer Initiation – Ultimate Debtor

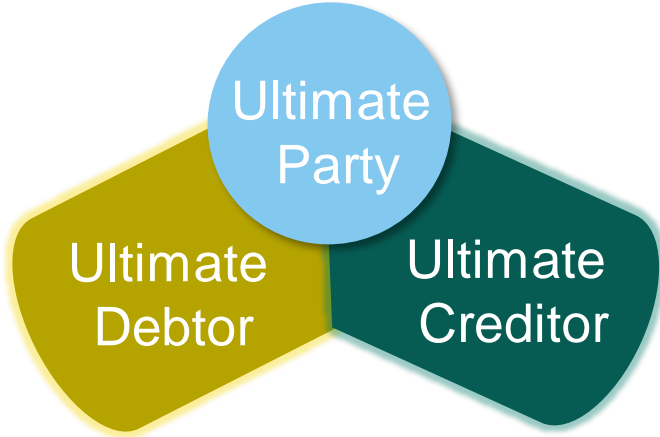

The pain.001 message introduces **Ultimate Debtor** and **Ultimate Creditor**. The **Ultimate Debtor** element should not be confused with an **Initiating Party** who may send a payment initiation request on behalf of the **Debtor**, for example, Payment Factory.

CBPR+ premise is that an **Ultimate Debtor** has no financial regulated direct account relationship with the corresponding Debtor. Likewise, an **Ultimate Creditor** has no financial regulated account relationship with the corresponding Creditor.

The **Ultimate Debtor** and **Ultimate Creditor** can be identified by a combination of Name and structured address or Organisation ID (e.g., BIC, LEI), Private ID and Country Of Residence.



Ultimate Debtor exists at the Payment Information Level and Transaction Level. Since CBPR+ interbank pain.001 is restricted to single transaction, Ultimate Debtor should be used at the Transaction Level unless bilaterally determined.

Credit Transfer Transaction Information 

 Ultimate Debtor

pain.001 Interbank Customer Credit Transfer Initiation – Intermediary Agents

Min 0 – Max 1

The pain.001 has three optional **Intermediary Agent (1,2 and 3)** elements. These agents represent the agent(s) that exist between the *Debtor Agent* and the *Creditor Agent*.



- If more than one intermediary agent is present, then **Intermediary Agent 1** identifies the agent between the *Debtor Agent* and the **Intermediary Agent 2**.
- If more than two intermediary agents are present, then **Intermediary Agent 2** identifies the agent between the **Intermediary Agent 1** and the **Intermediary Agent 3**.
- If **Intermediary Agent 3** is present, then it identifies the agent between the **Intermediary Agent 2** and the *Creditor Agent*.



More commonly the ISO 9362 Financial Institution **Business Identifier Code** is considered the best practice de factor standard for 'many to many' / correspondent banking payments.

Other options to identify the **Intermediary Agent** include:



- Clearing System Member ID
- LEI (Legal Entity Identifier)
- Name and either structured, or unstructured Postal Address



In order to process the pain.001 interbank into a CBPR+ payment, CBPR+ requires either structured or unstructured postal address.



[Take me to an explanation of CGI Postal Address](#)

Credit Transfer Transaction Information

Intermediary Agent 1

Intermediary Agent 2

Intermediary Agent 3

pain.001 Interbank Customer Credit Transfer Initiation – Intermediary Agent Account

The pain.001 **Intermediary Agent (1,2 and 3) Accounts** are used to capture the account information related to these Agents.

The **Intermediary Agent Account** uses a variety of nested elements to capture information related to the account.



- Min 1 – Max 1 Identification** identifies the account maintained at the Account Servicing Institution.
- Min 0 – Max 1 Type** uses the external Cash Account Type code list to identify the type of account.
- Min 0 – Max 1 Currency** identifies the currency of the account.
- Min 0 – Max 1 Name** identifies the name of the account as assigned by the Account Servicing Institution.
- Min 0 – Max 1 Proxy** captures an alternative identification of the account number such as an email address. This element has further nested **Type** which is a choice of external code list or proprietary code and **Identification** which are both mandatory where the Proxy element is used.



Intermediary Agent is a Financial Institution, therefore the nested elements **Name** and **Proxy** are unlikely to be used.

Credit Transfer Transaction Information

- Intermediary Agent Account 1
- Intermediary Agent Account 2
- Intermediary Agent Account 3

pain.001 Interbank Customer Credit Transfer Initiation – Creditor Agent

Min 0 – Max 1

The **Creditor Agent** is a static roles in the pain.001 Customer Credit Transfer Initiation. This agent maintain a relationship with their customers, the **Creditor**.



Note: Although the **Debtor Agent, Creditor Agent, Debtor and Creditor** all maintain static roles in the pain messages, the description of these parties change in the reporting messages (camt) where the Debtor Agent and Creditor Agent become the Statement Account Servicer and the Debtor and Creditor become the Statement Account Owner. This will be explored further in the camt Cash Management Reporting section.



For Agent Identification, BIC is preferred, alternatively Clearing Member ID together with Name and Address may be provided.

Credit Transfer Transaction Information 

 Creditor Agent

pain.001 Interbank Customer Credit Transfer Initiation – Creditor Agent Account

Min 0 – Max 1

The pain.001 **Creditor Agent Account** is used to capture the account information related to the *Creditor Agent*.

The **Creditor Agent Account** uses a variety of nested elements to capture information related to the account.



Min 1 – Max 1

Identification identifies the account maintained at the Account Servicing Institution

Min 0 – Max 1

Type uses the external Cash Account Type code list to identify the type of account

Min 0 – Max 1

Currency identifies the currency of the account

Min 0 – Max 1

Name identifies the name of the account as assigned by the Account Servicing Institution

Min 0 – Max 1

Proxy captures an alternative identification of the account number such as an email address. This element has further nested **Type** which is a choice of external code list or proprietary code and **Identification** which are both mandatory where the Proxy element is used.



Debtor Agent and Creditor Agent are Financial Institutions, therefore the nested elements **Name** and **Proxy** are unlikely to be used.



Credit Transfer Transaction Information

Creditor Agent Account

pain.001 Interbank Customer Credit Transfer Initiation – Creditor

Min 1 – Max 1

The ISO 2022 pain messages describe the **Creditor** as the party whose account was credited for a transaction. The *Creditor* sub elements describe the *Creditor* in greater detail.

Mandatory **Name** (where a BIC identifier is not provided) by which the party is known

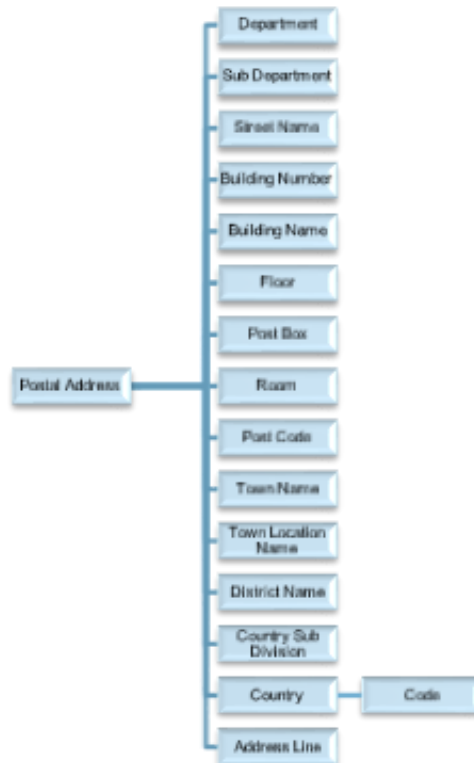

Nested element capturing either structured or unstructured *Creditor* address details.



Note: Structured address is strongly recommended with mandatory Town Name and Country

Nested element capturing the various types of identifiers for the party e.g. BIC, LEI etc.

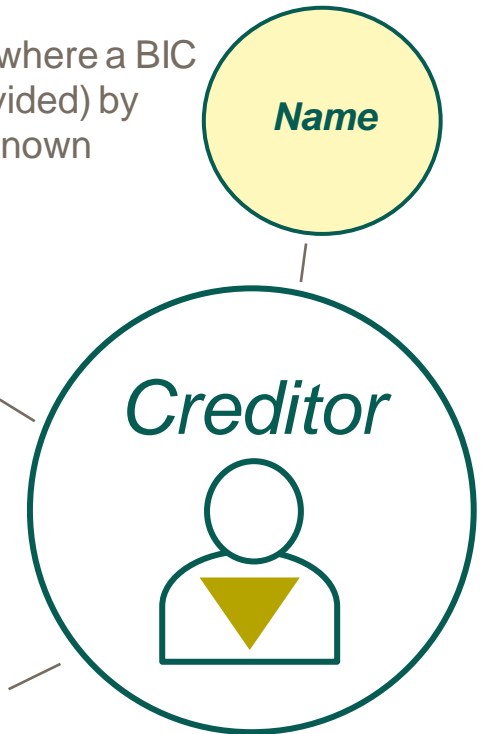
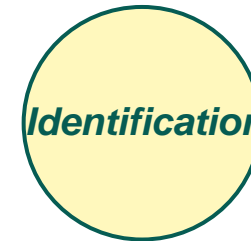

Optional element to capture the *Creditor's* ISO country code of residence



In order to process the pain.001 interbank into a CBPR+ payment, CBPR+ requires either structured or unstructured postal address.



[Take me to an explanation of CGI Postal Address](#)

pain.001 Interbank Customer Credit Transfer Initiation – Creditor Account

Min 0 – Max 1

The pain.001 **Creditor Account** is used to capture the account information for which credit entry will be made as a result of the transaction, which will be also reflected in their account Statement.

The **Creditor Account** uses a variety of nested elements to capture information related to the account.



Min 1 – Max 1 Identification identifies the account maintained at the Creditor Agent (Account Servicing Institution)

Min 0 – Max 1 Type uses the external Cash Account Type code list to identify the type of account

Min 0 – Max 1 Currency identifies the currency of the account

Min 0 – Max 1 Name identifies the name of the account as assigned by the Creditor Agent (Account Servicing Institution)

Min 0 – Max 1 Proxy captures an alternative identification of the account number such as an email address. This element has further nested **Type** which is a choice of external code list or proprietary code and **Identification** which are both mandatory where the Proxy element is used.



Creditor Account is not required for cheque payments.

Credit Transfer Transaction Information

Creditor Account

pain.001 Interbank Customer Credit Transfer Initiation – Ultimate Creditor

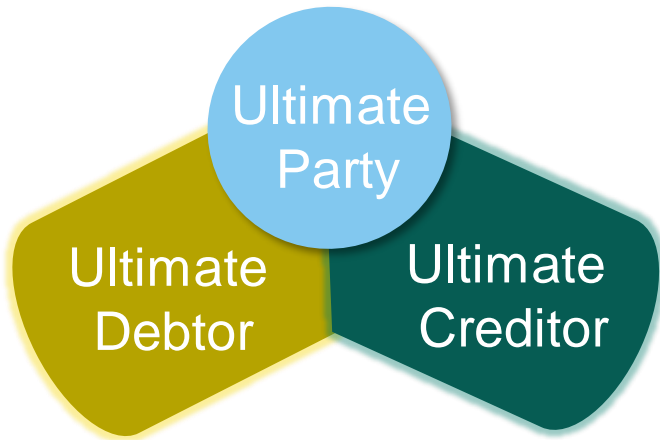

The pain.001 message introduces **Ultimate Debtor** and **Ultimate Creditor**. The **Ultimate Debtor** element should not be confused with an **Initiating Party** who may send a payment initiation request on behalf of the **Debtor**, for example, Payment Factory.

CBPR+ premise is that an **Ultimate Debtor** has no financial regulated direct account relationship with the corresponding Debtor. Likewise, an **Ultimate Creditor** has no financial regulated account relationship with the corresponding Creditor.

The **Ultimate Debtor** and **Ultimate Creditor** can be identified by a combination of Name and structured address or Organisation ID (e.g., BIC, LEI), Private ID and Country Of Residence.

Credit Transfer Transaction Information ✓

➤ Ultimate Creditor



pain.001 Interbank Customer Credit Transfer Initiation – Instruction For Creditor Agent

Min 0 – Max 2

The ***Instruction for Creditor Agent*** element within the pain.001 message optionally provides information related to the processing of the payment for the Creditor Agent.

The ***Instruction for Creditor Agent*** element offers a multiplicity of up to 2 occurrences of information. This element enables:

- the use of an embedded choice of code to describe the instruction (e.g. CHQB – Pay Creditor by Cheque)
- free format *instruction information*
- or both, where the free format complements the code.

The use of this element may be **bilaterally** agreed with the *Creditor Agent*. It must be passed on throughout the life cycle of the transaction until the payment reaches the *Credit Agent*.



Note that usage of these codes may trigger non-STP with potential additional costs involved or potential rejects of payments.

Credit Transfer Transaction Information 

 Instruction for Creditor Agent



ISO 20022 Programme

Quality data, quality payments

CBPR+ User Handbook

SR 2023 Edition

March 2023

pain.001 Interbank Customer Credit Transfer Initiation – Instruction For Debtor Agent

Min 0 – Max 1

The ***Instruction for Debtor Agent*** element within the pain.001 message optionally provides information related to the processing of the payment.



The ***Instruction for Debtor Agent*** element offers a maximum of 140 characters to further information related to the processing of the payment instruction, that may need to be acted upon by the *Debtor Agent*, depending on bilateral agreement.

Credit Transfer Transaction Information 

 Instruction for Debtor Agent

pain.001 Interbank Customer Credit Transfer Initiation – Purpose

Min 0 – Max 1

The **Purpose** element within the pain.001 message captures the reason for the payment transaction which may either use an external ISO **Purpose code** or a proprietary code.

The purpose is used to capture the nature of the payment, e.g., **IVPT** Invoice Payment, **FEES** Payment of Fees etc. and should not be confused with Regulatory Reporting codes. By definition this information is typically defined by the *Debtor*.



The externalised Purpose code set is classified by the purpose, for example commercial, for which the numerous codes within the classification are each described by Name and Definition.

For example, **LIMA** is classified within the Cash Management categorisation, with the *Name* Liquidity Management described as a **Bank initiated account transfer to support zero target balance management, pooling or sweeping**.



Category Purpose also captures a high-level purpose, which unlike **Purpose** is less granular but can trigger special processing e.g., Category Purpose code **SALA** ‘Salary Payment’ may trigger a reporting process which restricts sensitive data i.e., individual salary names.

Credit Transfer Transaction Information 

 Purpose

pain.001 Interbank Customer Credit Transfer Initiation – Regulatory Reporting

Min 0 – Max 10

The **Regulatory Reporting** block within the pain.001 message is nested to capture regulatory and statutory information needed to report to the appropriate authority/s.

Min 0 – Max 1

The **Debit Credit Reporting Indicator** utilises an embedded choice of code to indicate whether the regulatory reporting applies to the:

- DEBT (debit)
- CRED (credit)
- BOTH

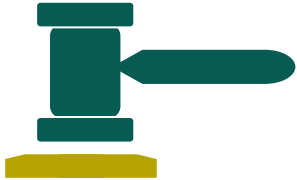

Min 0 – Max 1

The **Authority** element captures the **Name** and **Country** code of the Authority/Entity requiring the regulatory reporting information.

Min 0 – Max *

The **Details** element provides the detail on the regulatory reporting information.

Credit Transfer Transaction Information > Regulatory Reporting ✓

⊗ Debit Credit Reporting Indicator

> Authority

> Details

pain.001 Interbank Customer Credit Transfer Initiation – Tax

Min 0 – Max 1

The pain.001 nested **Tax** element captures information related to tax. The tax information block is applicable when tax information is used by the clearing or the local regulatory authority(s).

This element caters for two main types of tax related payments:

- Tax payment obligation that is required to be transmitted with a payment
- Information that accompanies an actual payment of a tax obligation

The follow nested elements may be used to capture detailed tax information:

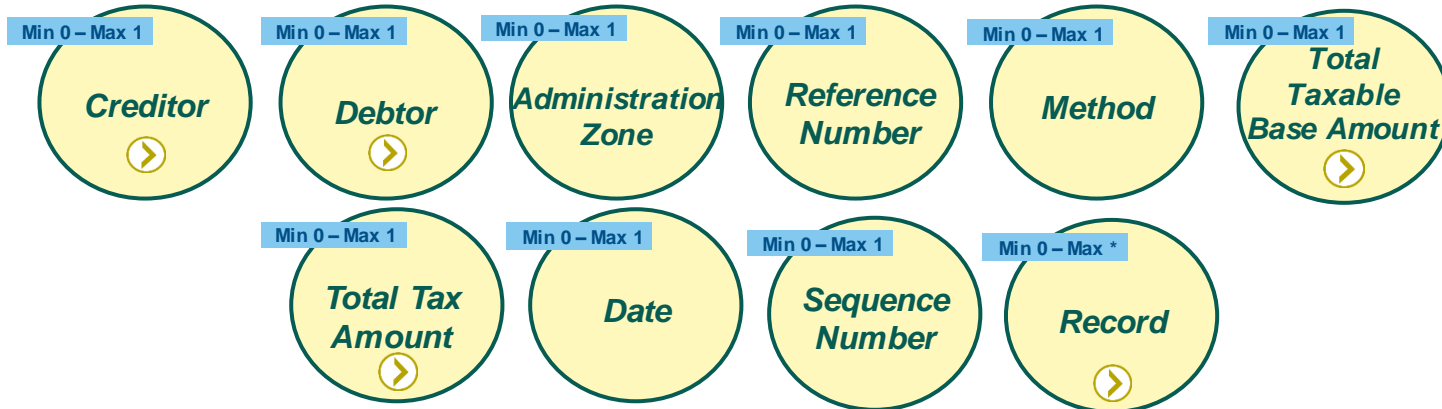

Tax information block is also available within the Structured Remittance Information block which is applicable when tax information is used by the creditor as part of remittance information.

Credit Transfer Transaction Information

Tax

pain.001 Interbank Customer Credit Transfer Initiation – Related Remittance Information

Min 0 – Max 10

The **Related Remittance Information** element within the pain.001 message is nested to provide information related to the handling of remittance information.

Min 0 – Max 1

The **Remittance Identification** captures a unique reference assigned by the initiating party of the payment to identify the remittance information sent separately from the payment instruction.

Min 0 – Max *

The **Remittance Location Details** uses a set of nested elements to provide information on either the location of or the delivery of remittance information.

- **Method** requires a code from an embedded list to detail the method used to deliver the remittance advise information e.g. EMAL (email)
- **Electronic Address** provides an electronic address for which an agent is to send the remittance information to e.g. the email address. It may also reference a URL where remittance information may be deposited or retrieved.
- **Postal Address** provides the postal address to which an agent is to send the remittance information



Unlike CBPR+ pacs messages, in the interbank pain.001 message, Related Remittance Information and Remittance Information are non-mutually exclusive due to a corporate use case of populating both information blocks for detailing remittance advices which are part of value-added service offered by the *Debtor Agent*.



SCORE Guideline: If the Related Remittance Information is used, and a Remittance Identification is provided, it is recommended that the Remittance Identification equal the End To End Identification.

Credit Transfer Transaction Information ✓

➤ Related Remittance Information

pain.001 Customer Credit Transfer Initiation – Remittance Information

Min 0 – Max 1

The optional **Remittance Information** element within the pain.001 message is nested to provide either **Structured** or **Unstructured** information related to payment, such as invoices.

Remittance Information enables the matching/reconciliation of an entry that the payment is intended to settle.

Min 0 – Max 1

The **Unstructured** sub element captures free format *Remittance Information* which is restricted in interbank CBPR+ to 140 characters to ensure backward compatibility with the legacy MT message during coexistence.



Min 0 – Max *

The **Structured** element is nested capturing rich structured *Remittance Information*, and is unlimited in its multiplicity, but must not exceed 9,000 characters of business information (does not include the xml element identification)

The use of this nested element should be bilaterally/multilaterally agreed, to ensure end-to-end transportation of this data.

Credit Transfer Transaction Information ✓

➤ Remittance Information

➤ Structured

➤ Unstructured

Recommend to refer to [CGI-MP Document Centre](#) for Country requirements on Remittance Information.



pain.001 Interbank Customer Credit Transfer Initiation – Structured Remittance Information

The bilaterally/multilaterally agreed **Remittance Information** which is **Structured** must not exceed 9,000 characters of business content (i.e. the information). This nested element is used to capture a variety of structured remittance information.

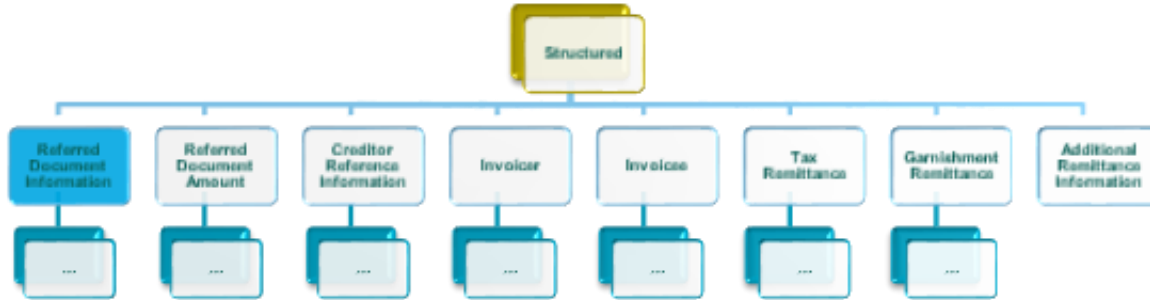

example of *Structured* invoice information

The **Creditor Remittance Information** is provided to the **Creditor** in the Cash Management Reporting messages' Remittance Information component, for example, the camt.053 Bank to Customer Statement.

Structured		<Strd>
Reference Document Information	<RfrdDoclrf>	<div style="border: 1px solid black; padding: 5px; display: inline-block;"> CINV A0000101 2019-10-29 </div>
Type	<Tp>	
Code Or Proprietary	<CdOrPrtry>	
Code	<Cd>	
Number	<Nb>	
Related Date	<Dt>	

Annotations: 'element names' points to the left column; 'xml tag' points to the right column; 'business information' points to the nested data box.



In this example Referred Document Information and its nested elements have multiplicity which support up to 9,000 character of information. Whereby this element can be repeated to include more coded information such as another invoice.

- Credit Transfer Transaction Information
- Remittance Information
- Structured

pain.001 Interbank Customer Credit Transfer Initiation – Structured Remittance Information

The **Creditor Reference** in the *Creditor Remittance Information* component in the structured remittance information is generated by *Creditor* to inform the *Debtor* who has to include the reference in the Remittance Information component of the pain.001.

Creditor Reference in the Structured Remittance Information is based on ISO 11649

- 2 letters “RF”
- 2 digits check digit
- 21 letters/digits creditor reference

Facilitates STP and auto-match with the creditor reference and its account receivable

- A vendor can add the creditor reference to its invoice. When a customer pays the invoice, they write the creditor reference instead of the invoice number in the payment message (e.g., MT 101 F70 which will be carried in MT 103)
- When the vendor receives the payment, it can auto-match the incoming credit entry and the creditor reference extracted from the statement (e.g., MT 940 F61/86)



SCORE Guideline: For Creditor Reference information, in instances where the Creditor Reference Type code is SCOR (Structured Communication Reference) and the Creditor Reference is structured in accordance with ISO 11649, the Issuer should be specified with the text ‘ISO’ (without the quote marks)

Credit Transfer Transaction Information 

 Remittance Information

 Structured



Index of pain.001 Use Cases

Use case should be considered as a principal example whereby use case may be cross referenced e.g., a use case involving a Market Infrastructure can apply the Market Infrastructure legs to other use cases.

Interbank Customer Credit Transfer Initiation - Relay

Use Case pn.1.1.1 – High Level Payment Initiation Interbank 'relay' (pain.001)

Use Case pn.1.1.1.a – High Level Payment Initiation Interbank 'relay' (pain.001) Multi-bank Sweep

Use Case pn.1.1.2 – High Level Payment Initiation Interbank 'relay' (pain.001) involving a Payment Market Infrastructure

Interbank Customer Credit Transfer Initiation – Authorised Party

Use Case pn.1.2.1 – High Level Payment Initiation Interbank (pain.001) by an Authorised Party

Use Case pn.1.2.1.a. – High Level Payment Initiation Interbank (pain.001) FI-Initiated Sweep (Long position at the Secondary Account)

Use Case pn.1.2.1.b. – High Level Payment Initiation Interbank (pain.001) by an Authorised Party to pay themselves as the Creditor

Interbank Customer Credit Transfer Initiation – Financial Institution

Use Case pn.1.3.1 – High Level Payment Initiation Interbank (pain.001) Financial Institution Payment Initiation



High Level Payment Initiation Interbank 'relay' (pain.001)

In the interbank relay scenario, the Forwarding Agent relays the pain.001 message to the Debtor Agent which will debit the account of the Debtor and initiate a credit transfer.

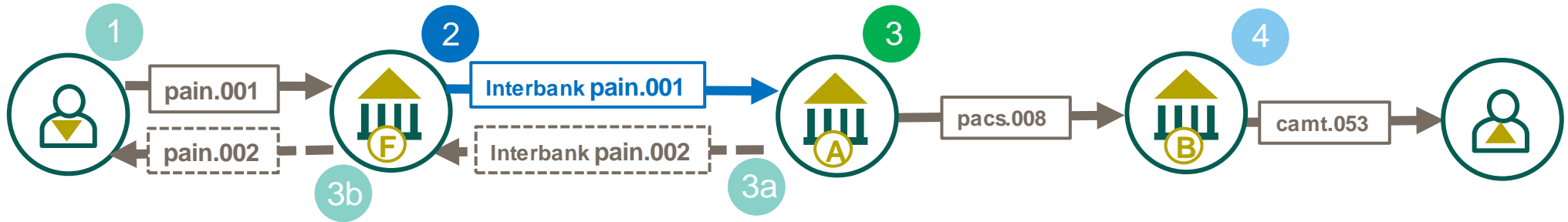

1 Initiating Party sends a payment instruction to the Forwarding Agent

2 Forwarding Agent (F) forwards the payment instruction to the Debtor Agent (A)

3 Debtor Agent (A) debits the account of Debtor and initiates a credit transfer by forwarding a local credit transfer message pacs.008

3a Debtor Agent (A) provides a status update ACSP (accepted settlement in progress) to the Forwarding Agent (F), based upon a bilateral agreement

3b Forwarding Agent (F) relays the status ACSP (accepted settlement in progress) to the Initiating Party, based upon a bilateral agreement

4 Creditor Agent (B) processes the payment and sends the statement to Creditor

High Level Payment Initiation Interbank 'relay' (pain.001) Multi-bank Sweep

In the interbank relay scenario, the Forwarding Agent relaying the pain.001 message to the Debtor Agent(s) in this case to sweep excess cash from the account of the Debtor and consolidate cash for a Corporate.

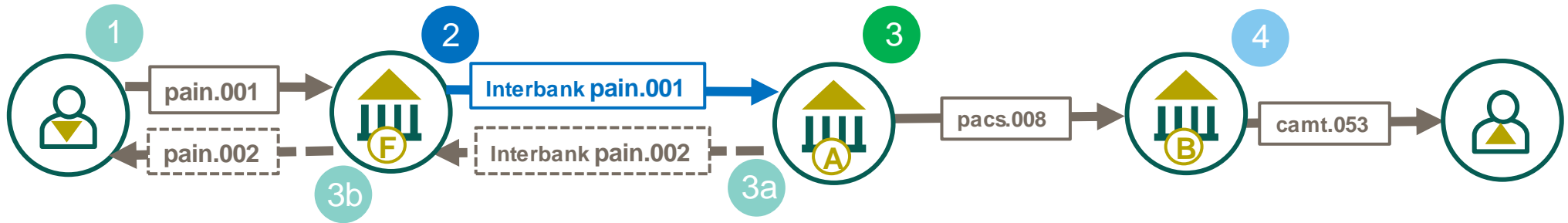

1 Initiating Party sends a payment instruction to the Forwarding Agent to sweep excess funds from its subsidiary's account to the master account with Bank B

2 Forwarding Agent (F) forwards the payment instruction to the Debtor Agent (A)

3 Debtor Agent (A) debits the account of Debtor and initiates a credit transfer by forwarding a local credit transfer message pacs.008

3a Debtor Agent (A) provides a status update ACSP (accepted settlement in progress) to the Forwarding Agent (F), based upon a bilateral agreement

3b Forwarding Agent (F) relays the status ACSP (accepted settlement in progress) to the Initiating Party, based upon a bilateral agreement

4 Creditor Agent (B) processes the payment and notifies Creditor of a successful sweep through the statement



High Level Payment Initiation Interbank 'relay' (pain.001) involving a Payment Market Infrastructure

In the interbank relay scenario, the Forwarding Agent relays the pain.001 message to the Debtor Agent which will debit the account of the Debtor initiate a credit transfer through a Payment Market Infrastructure.

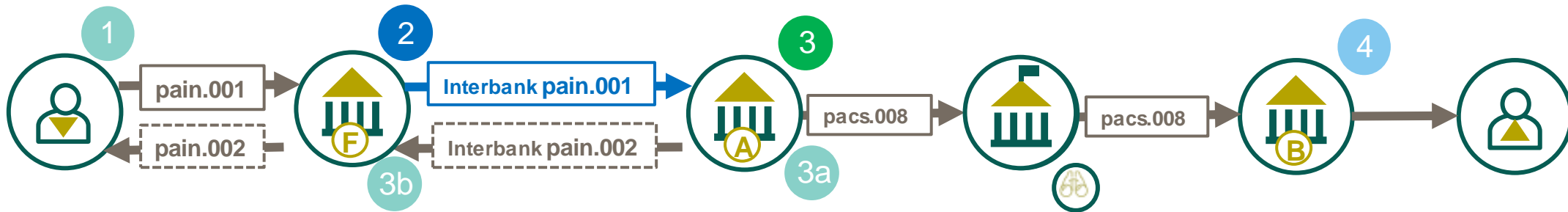

1 Initiating Party sends a payment instruction to the Forwarding Agent

2 Forwarding Agent (F) forwards the payment instruction to the Debtor Agent (A)

3 Debtor Agent (A) debits the account of Debtor and initiates a credit transfer by forwarding a local credit transfer message pacs.008 to a Payment Market Infrastructure (PMI)

3a Debtor Agent (A) provides a status update ACSP (accepted settlement in progress) to the Forwarding Agent (F), based upon a bilateral agreement

3b Forwarding Agent (F) relays the status ACSP (accepted settlement in progress) to the Initiating Party, based upon a bilateral agreement

4 Creditor Agent (B) receives local credit transfer message via the Payment Market Infrastructure (PMI) and credits the Creditor



High Level Payment Initiation Interbank (pain.001) by an Authorised Party

In the scenario Authorised Party Initiation, the Initiating Party (Agent I) initiates a payment from the Debtor's account based on Debit Authorisation already in place between the Debtor and the Debtor Agent

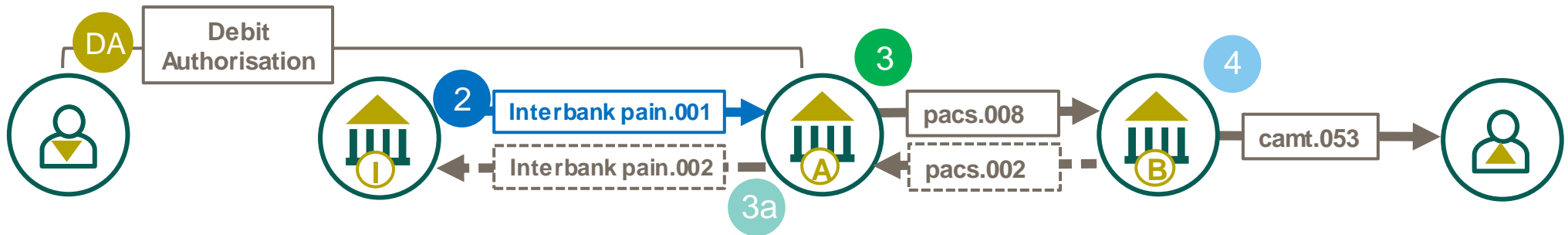

DA As a pre-requisite the Debtor provides Debit Authorisation to Agent I, which allows Agent I to Initiate Payment from their account

2 Agent (I) initiates a payment request (pain.001) to the Debtor Agent (A) to move fund from the Debtor's account, as an authorised party.

3 Debtor Agent (A) debits the account of Debtor and initiates a credit transfer

3a Debtor Agent (A) optionally provides a status update to the Initiating Party (Agent I), based upon a bilateral agreement

4 Creditor Agent (B) receives the credit transfer message, credits the Creditor, and sends a camt.053 (statement) at the end of the business day to the Creditor. An optional status report is sent to the previous Agent based upon a bilateral agreement

High Level Payment Initiation Interbank (pain.001) FI-Initiated Sweep (Long position at the Secondary Account)

In the interbank sweep scenario, the Initiating Party (Agent I) initiates the pain.001 message to the Debtor Agent to sweep excess cash from the account of the Debtor and consolidate the cash for a Corporate.

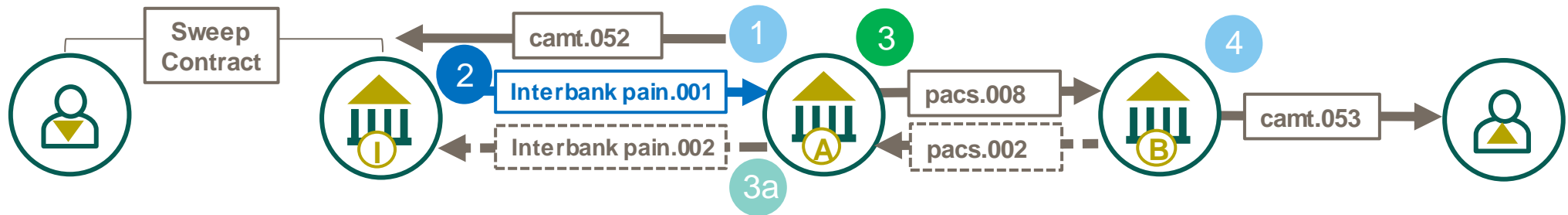

1 Agent I receives intraday balance report from Debtor Agent (A) on behalf of their mutual customer.

2 Agent (I) initiates a sweep on behalf of the Corporate by sending pain.001 to the Debtor Agent

3 Debtor Agent (A) debits the account of Debtor and initiates a credit transfer

3a Debtor Agent (A) optionally provides a status update to the Initiating Party (Agent I), based upon a bilateral agreement

4 Creditor Agent (B) receives credit transfer message, credits the Creditor, and sends a camt.053 (statement) at the end of the business day to the Creditor. An optional status report is sent to the previous Agent based upon a bilateral agreement

 See use case [p.8.1.2](#) for a sweeping contract with a short position

High Level Payment Initiation Interbank (pain.001) by an Authorised Party to pay themselves as the Creditor.

In the Authorised Party Initiation scenario, the Initiating Party (Agent I) initiates a payment from the Debtor's account based on Debit Authorisation already in place to move money to themselves as the Creditor

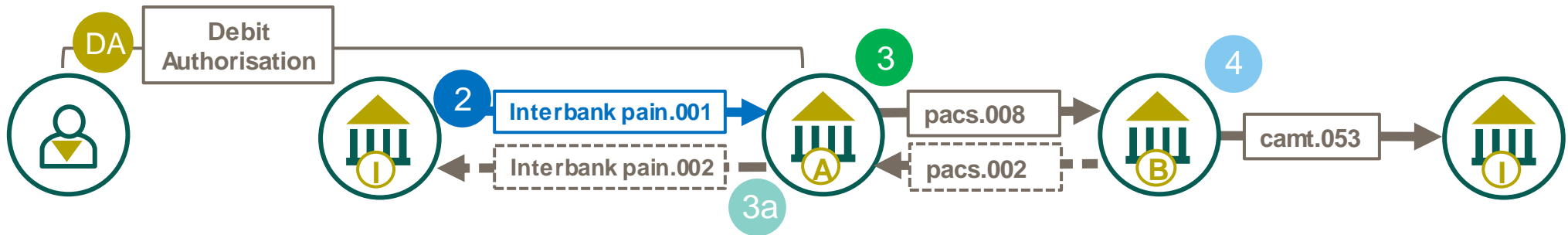

DA
As a pre-requisite the Debtor provides Debit Authorisation to Agent I to Initiate Payment from their account with the Debtor Agent (A)

2
Agent (I) initiates a payment request (pain.001) to the Debtor Agent (A) to move fund from the Debtor's account, as an authorised party, to themselves as the Creditor

3
Debtor Agent (A) debits the account of Debtor and initiates a credit transfer

3a
Debtor Agent (A) optionally provides a status update to the Initiating Party (Agent I), based upon a bilateral agreement

4
Creditor Agent (B) receives the credit transfer message, credits the Creditor, and sends a camt.053 (statement) at the end of the business day to the Creditor. An optional status report is sent to the previous Agent based upon a bilateral agreement



High Level Payment Initiation Interbank (pain.001) Financial Institution Payment Initiation

Use Case pn.1.3.1

The Initiating Party (Agent I) initiates a payment from their own account with the Debtor Agent to move the funds to a non-Financial Institution Creditor

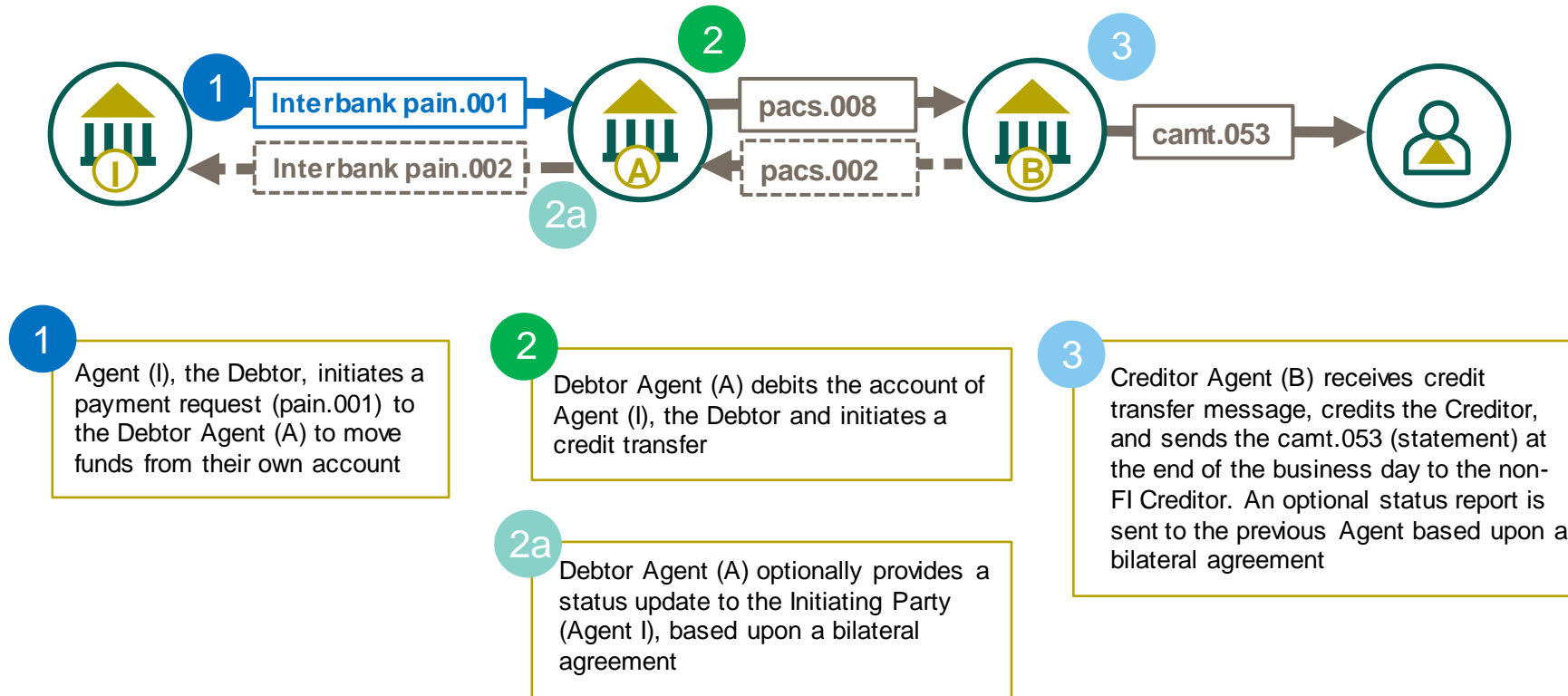

1 Agent (I), the Debtor, initiates a payment request (pain.001) to the Debtor Agent (A) to move funds from their own account

2 Debtor Agent (A) debits the account of Agent (I), the Debtor and initiates a credit transfer

2a Debtor Agent (A) optionally provides a status update to the Initiating Party (Agent I), based upon a bilateral agreement

3 Creditor Agent (B) receives credit transfer message, credits the Creditor, and sends the camt.053 (statement) at the end of the business day to the non-FI Creditor. An optional status report is sent to the previous Agent based upon a bilateral agreement

pain.002

Interbank Customer Payment Status Report



pain.002 Interbank Customer Payment Status Report

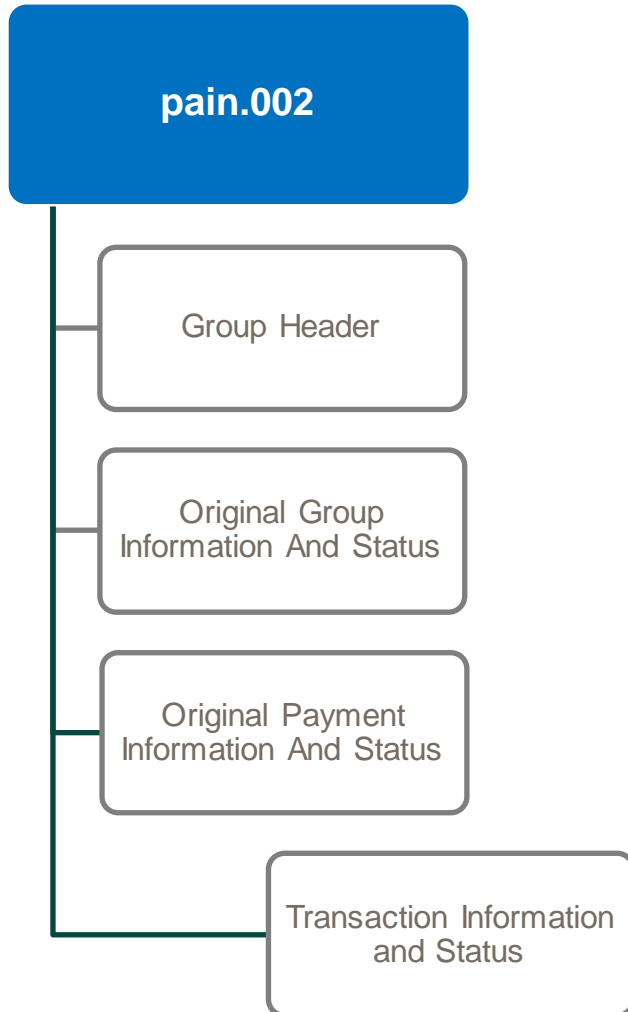

The pain.002 message is composed of four building blocks:

- **Group Header** which contains a set of characteristics shared by all individual transactions in the message.
- **Original Group Information and Status** contains the group of transactions, to which the status report message refers to.
- **Original Payment Information And Status** contains information about the original payment information, to which the status report message refers.
- **Transaction Information And Status** provides information on the original transactions to which the status report message refers.

It is used to inform the previous party in the payment chain about the positive or negative status of an instruction. It is also used to report on a pending instruction.

High Level serial message flow: Payment Status Report “Relay”

pain.002

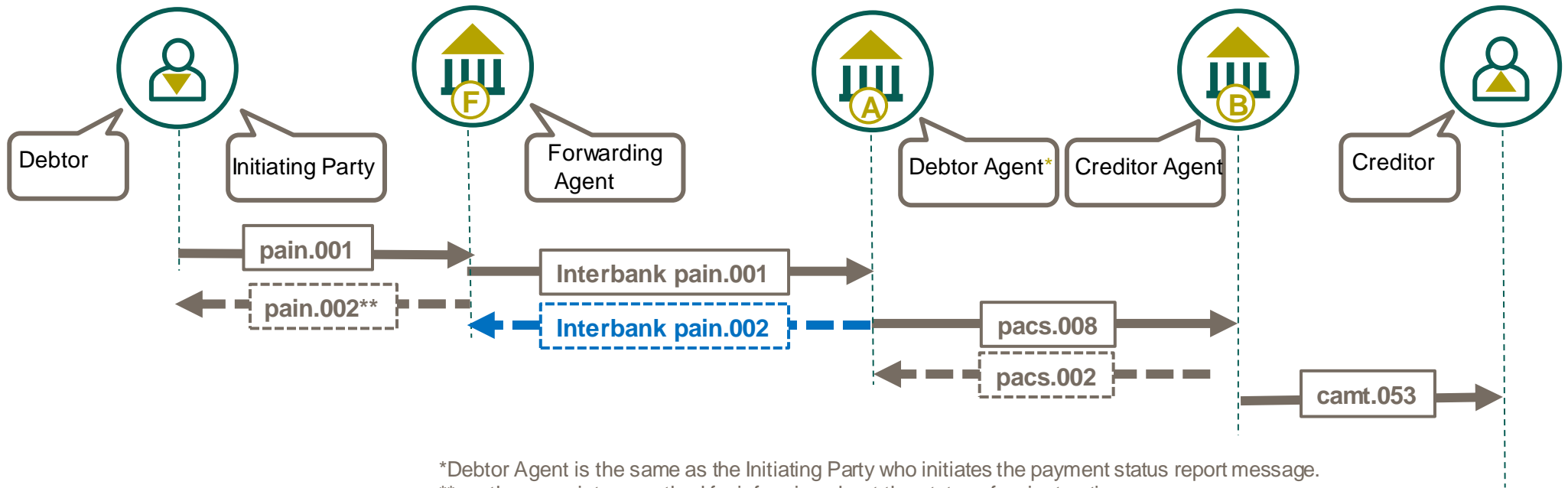

*Debtor Agent is the same as the Initiating Party who initiates the payment status report message.
 **or other proprietary method for informing about the status of an instruction

Interbank Customer Payment Status Report message is sent by the Debtor Agent to the previous agent in the payment chain. It is used to provide notification of a rejected status, as required. The provision of a positive status is determined by a bilateral agreement between the agents. There are three common use cases:

- 1 **Relay.** The pain.002 message is sent by the Debtor Agent to the Forwarding Agent which acts as a concentrating financial institution. It will forward the pain.002 message to the Initiating Party.



Noting in CGI-MP a pain.002 may also be sent by the Debtor Agent directly to the Initiating Party/Debtor which is outside of the scope of CBPR+, however the CBPR+ interbank pain.001 message is interoperable with CGHMP.

High Level serial message flow: Payment Status Report “Relay”

pain.002

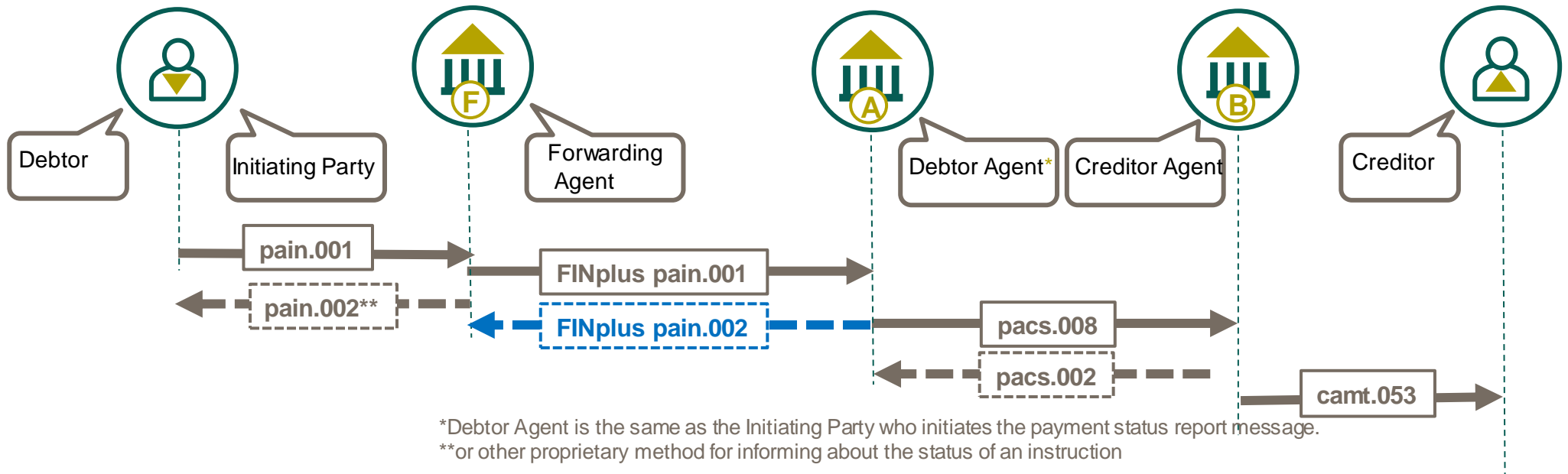

FINplus Customer Payment Status Report message is sent by the Debtor Agent to the previous agent in the payment chain. It is used to provide notification of a rejected status, as required. The provision of a positive status is determined by a bilateral agreement between the agents. There are three common use cases:

- 1 Relay:** The pain.002 message is sent by the Debtor Agent to the Forwarding Agent which acts as a concentrating financial institution. It will forward the pain.002 message to the Initiating Party.



A Payment Initiation Rulebook, available in the [Standards Documentation Centre](#), replaces the legacy MT Request for Transfer Service Level Agreement.

Noting in CGI-MP a pain.002 may also be sent by the Debtor Agent directly to the Initiating Party/Debtor which is outside of the scope of CBPR+, however the CBPR+ FINplus pain.001 message is interoperable with CGI-MP.

High Level serial message flow: Payment Status Report “FI Payment Initiation”

pain.002

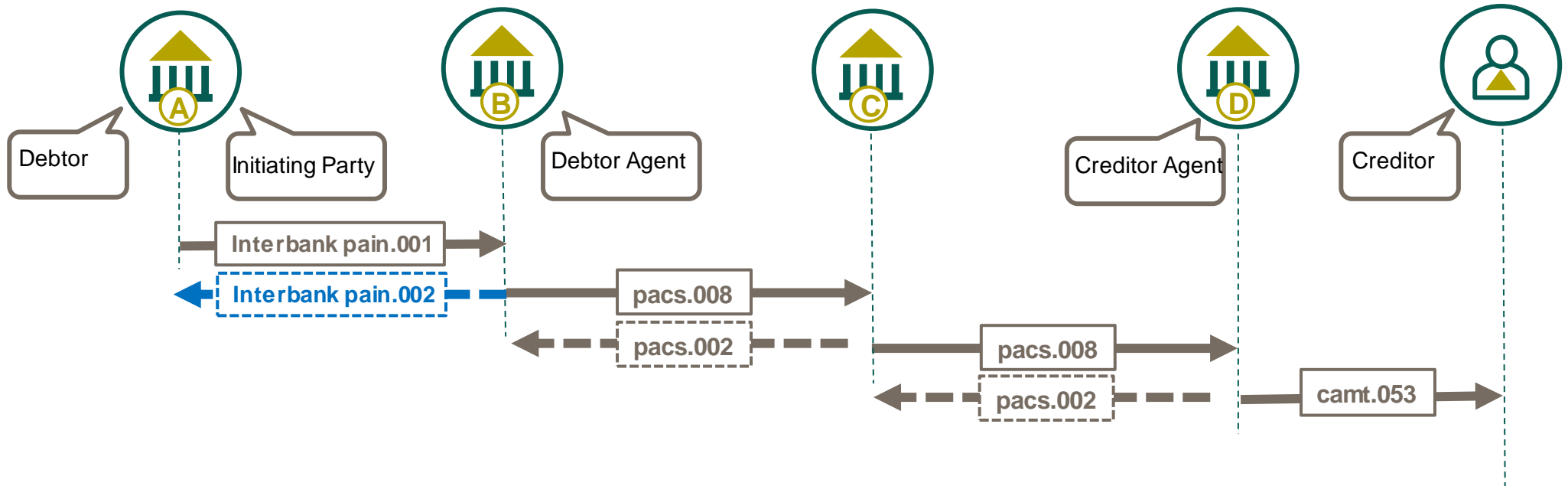

Interbank Customer Payment Status Report message is sent by the Debtor Agent to the previous agent in the payment chain. It is used to provide notification of a rejected status, as required. The provision of a positive status is determined by a bilateral agreement between the agents. There are three common use cases:

- 3 Financial Institution Payment Initiation (to non-FI) :** The pain.002 message is sent by the Debtor Agent to the Debtor (Financial Institution) who requested to initiate a payment from their account with the Debtor Agent to move funds to a non-Financial Institution Creditor.



High Level serial message flow: Payment Status Report “Direct Debit Initiation Relay”

pain.002

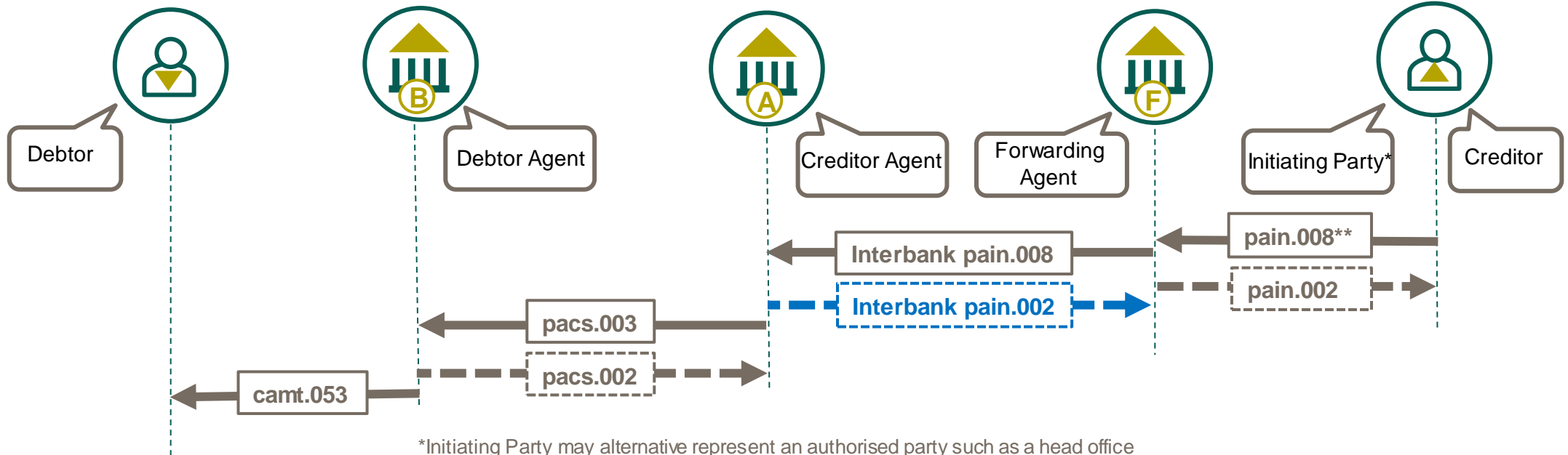

*Initiating Party may alternative represent an authorised party such as a head office
 **or other proprietary method for instructing a direct debit initiation request.

Interbank Customer Direct Debit Initiation message is sent by the Initiating Party to the Forwarding Agent or the Creditor Agent. It is used to request single or bulk collection(s) of funds from one or various debtor’s account(s) to a creditor.

Relay: Interbank pain.008 message is sent by the Initiating party (the Creditor or authorised party) to the Forwarding Agent which acts as a concentrating financial institution. It will forward the pain.008 message to the Creditor Agent to initiate the direct debit instruction(s).



*Noting in CGI-MP pain.008 may also be sent by the Initiating Party/Creditor directly to the Creditor Agent which is outside of the scope of CBPR+.

Group Header



pain.002 Interbank Customer Payment Status Report - Message Identification

Min 1 – Max 1



Each ISO20022 payment message has a **Message Identification** element, located in the Group Header. This **35 character** identifier is a point-to-point reference used to unambiguously identify the message.

For Payment Initiation (pain) messages the Message Identification has no exact equivalent in the legacy MT payment message. However, the Sender's Reference (Field 20) could be considered as a similar comparison where a pain message contains a single Transaction.



Each transaction's *Credit Transfer Transaction Information* contains a variety of nested *Payment Identification* elements to capture reference related to the individual transaction such as a UETR (Unique End-to-end Transaction Reference).



For a relay scenario, Forwarding Agent should respect the Message ID provided by the Initiating Party (Debtor Agent) of the pain.002.

Group Header ➤ Message Identification

pain.002 Interbank Customer Payment Status Report – Creation Date Time

Min 1 – Max 1

The pain.001 message **Creation Date Time** captures the date and time the message was created.

It is defined by **ISO Date Time** with mandatory date and time components expressed in the following formats:

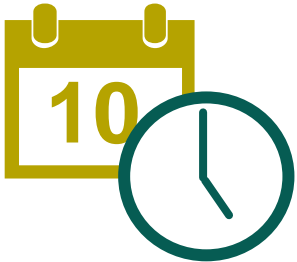

1. Universal Time Coordinated (UTC) time **YYYY-MM-DDThh:mm:ss.sssZ**
2. Local time with UTC offset **YYYY-MM-DDThh:mm:ss.sss+/-hh:mm**
3. Local time format **YYYY-MM-DDThh:mm:ss.sss**



Unlike other CBPR+ messages, the interbank pain.001 message is more flexible in defining the date and time elements. The most recommended representation is Local time with UTC offset which was mandated by CBPR+ (2nd option). Otherwise use UTC time (1st option). Decimal fractions of seconds with 3 digits. Milliseconds are optional.

pain.002 Interbank Customer Payment Status Report – Initiating Party

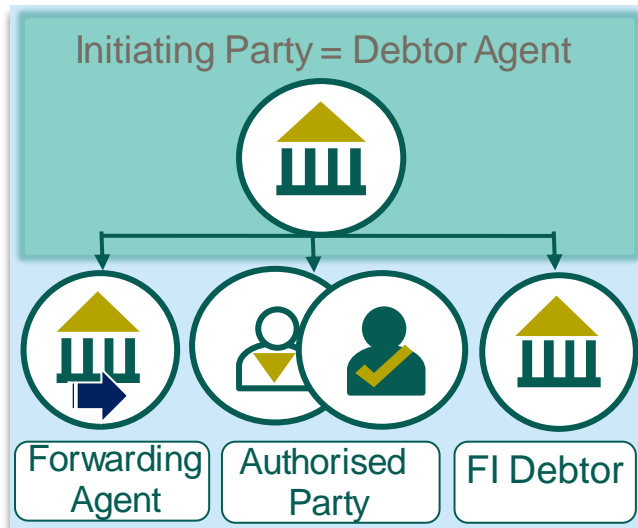

Min 1 – Max 1

The **Initiating Party** in the context of interbank payment initiation report is always the **Debtor Agent** which initiates the pain.002 message. **Business Identifier Code** (BIC FI) is mandated to identify the **Initiating Party** in the pain.002 message. There are three use cases below:

1. **Relay:** The **Debtor Agent** sends the pain.002 message to the **Forwarding Agent** which acts as a concentrating financial institution. It will forward the pain.002 message to the original **Initiating Party** who can be the **Debtor** themselves or the **Authorised Party**. This is commonly known as a relay scenario.
2. **Authorised Party:** The **Debtor Agent** sends the pain.002 to the **Financial Institution (Initiating Party)** which has the authority to initiate a payment on behalf of the **Debtor**, e.g., multi-bank liquidity sweeps
3. **Financial Institution Payment Initiation:** The **Debtor Agent** sends the pain.002 to the **Financial Institution** which is the **Debtor** who initiate a payment from their account to move funds to a non-Financial Institution **Creditor**

Group Header ➤ Initiating Party

pain.002 Interbank Customer Payment Status Report – Forwarding Agent



Min 0 – Max 1

The **Forwarding Agent** is mandatory in a relay scenario whereby the receiver of the pain.002 message is not the original Debtor. In this case, the *Initiating Party* (the *Debtor Agent*) has to provide **Business Identifier Code** (BIC FI) of the *Forwarding Agent* in the pain.002 message. The Forwarding Agent *acts as a concentrating financial institution and forwards the pain.002 message to the Debtor or the Initiating Party.*

Other options to identify the **Forwarding Agent** include:

- Clearing System Member ID
- LEI (Legal Entity Identifier)

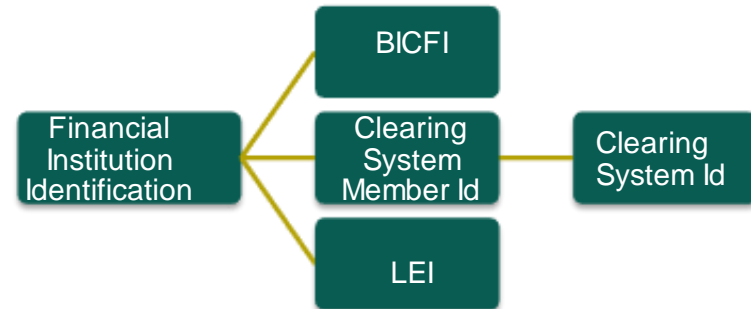

For the use case of multi-bank liquidity sweeps, Forwarding Agent is not required.

Group Header ➤ Forwarding Agent

Original Group Information and Status



pain.002 Interbank Customer Payment Status Report – Original Group Information and Status

Min 1 – Max 1

The pain.002 Customer Payment Status Report uses elements in the **Original Group Information and Status** to capture the message identifier and message name of the underlying payment the *Payment Status Report* relates to. The mandatory **Original Message Identification** contains the point-to-point reference, and the mandatory **Original Message Name Identification** contains the message name of the underlying payment being reported upon. Optionally the **Original Creation Date Time** can also be captured.

For example:

Original Message Name Identification
 “pain.001.001.09” confirms the Status Report is of a pain.001 Customer Credit Transfer Initiation.



Original Message Identification must transport the Message Identification of the underlying payment (e.g., pain.001).



For a relay scenario, Forwarding Agent (F) should respect the Message ID provided by the Initiating Party of the pain.001 and pain.002.

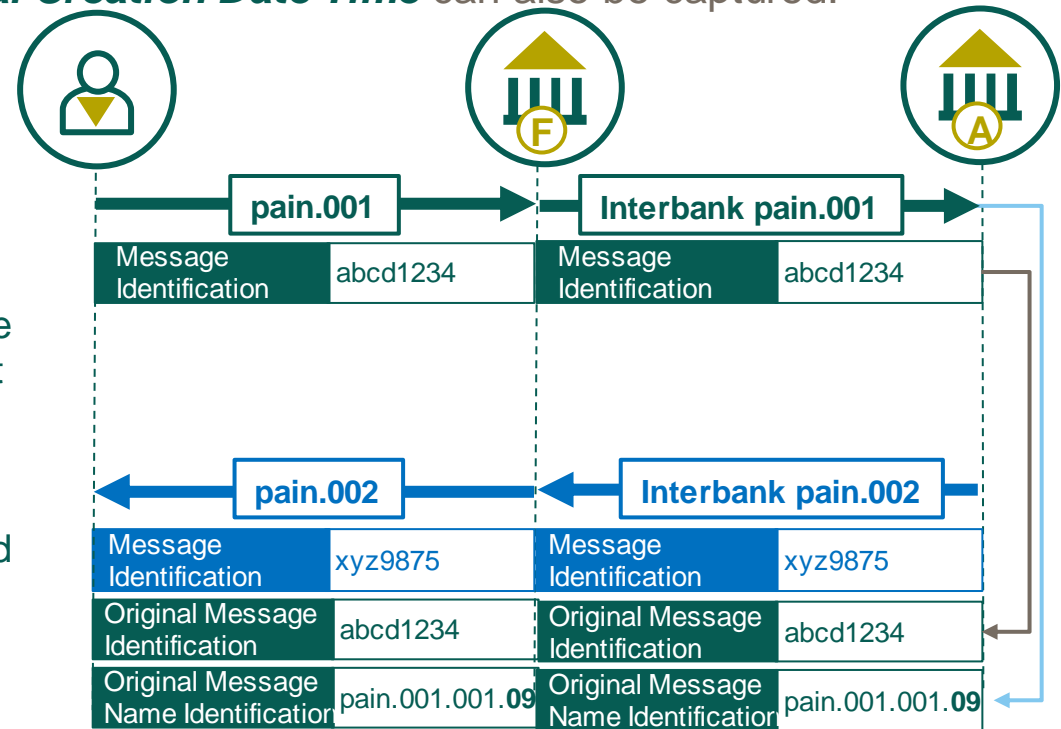

pain.002 Interbank Customer Payment Status Report – Original Payment Information Identification

Min 1 – Max 1



The pain.002 Customer Payment Status Report uses element ***Original Payment Information Identification***, located in the Original Group Information and Status. This 35 character identifier is a point-to-point reference used to unambiguously identify the payment information group or batch reference if the message contains multiple transactions.



Since the interbank pain.001 and pain.002 usage guidelines are restricted to one single transaction, this value is the same as the Original Message ID of the Original Group Information And Status.

➤ Original Payment Information and Status ✓

➤ Original Payment Information Identification

pain.002 Interbank Customer Payment Status Report – Original elements

Min 1 – Max 1

The pain.002 *Customer Payment Status Report* nested **Transaction Information And Status** element is used to capture information from the underlying payment that the *Payment Status Report* relates to.

Mandatory element (in addition to *Original Message identification* and *Original Message Name Identification* described on the previous pages) include:

Original End to End Identification

Min 1 – Max 1

Original UETR

Min 1 – Max 1

The following element is optional:

Original Instruction Identification

Min 0 – Max 1

These Original elements enable the **Initiating Party** to associate the Payment Status with the payment they originally sent.

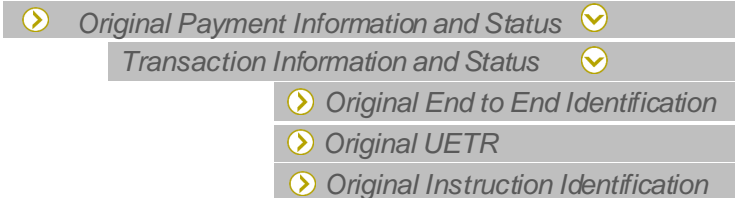

pain.002 Interbank Customer Payment Status Report – Transaction Status and Status Reason Information

Min 1 – Max 1

The pain.002 *Customer Payment Status Report* **Transaction Status** utilizes the externalized ISO *Payment Transaction Status* code list to provide a status update on a pain message previously received. The *Transaction Status* element is arguable the most significant/core parts of the pain.002 and optionally may further be complimented with **Status Reason Information**.

Min 0 – Max 1



The nested **Status Reason Information** enable the optional inclusion of:
Originator – the party that issues the status. Typically, the pain.002 Initiating Party and therefore Originator is not necessary.

Reason – which utilises an ISO external Status Reason code. For example, **AC04** 'Closed Account Number' would compliment a RJCT (Reject) Transaction Status.

Additional Information – a text element to provide further status reason information, necessary where the *Reason* code is NARR



Note: A **Reason** code must be provided where the **Transaction Status** RJCT (Reject) code is used.

pain.002 Interbank Customer Payment Status Report - Payment Transaction Status Code

Definitions and High Level Use Cases

Code	Name	ISO Definition	High Level Use Case
ACCC	AcceptedSettlementCompleted	Settlement on the creditor's account has been completed.	Sent by Creditor Agent to confirm the settlement on the creditor's account
ACCP	AcceptedCustomerProfile	Preceding check of technical validation was successful. Customer profile check was also successful.	Sent by any Agent in the payment chain to confirm acceptance prior to technical validation.
ACFC	AcceptedFundsChecked	Preceding check of technical validation and customer profile was successful and an automatic funds check was positive.	Sent by any Agent in the payment chain to confirm the technical validation/profile was positive and automatic funds check was positive.
ACIS	AcceptedandChequeIssued	Payment instruction to issue a cheque has been accepted, and the cheque has been issued but not yet been deposited or cleared.	Sent by any Agent in the payment chain to confirm a cheque has been issued as requested.
ACSC	AcceptedSettlementCompleted	Settlement has been completed.	Sent by the Any Agent to confirm settlement of a payment message leg.
ACSP	AcceptedSettlementInProgress	All preceding checks such as technical validation and customer profile were successful and therefore the payment initiation has been accepted for execution.	Sent by any Agent to the to confirm the payment is accepted following technical validations being successfully completed.
ACTC	AcceptedTechnicalValidation	Authentication and syntactical and semantical validation are successful	Sent by any Agent in the payment chain to the previous Agent to confirm the payment is accepted following technical validations being successfully completed.
ACWC	AcceptedWithChange	Instruction is accepted but a change will be made, such as date or remittance not sent.	Sent by any Agent in the payment chain to the previous Agent to confirm the payment is accepted following amendments being made.
ACWP	AcceptedWithoutPosting	Payment instruction included in the credit transfer is accepted without being posted to the creditor customer's account.	Sent by Creditor Agent to the previous Agent to confirm the acceptance of payment without settlement on the creditor's account,
CPUC	CashPickedUpByCreditor	Cash has been picked up by the Creditor.	Sent by Creditor Agent to the previous Agent to confirm that the cash collection has been picked up by the Creditor,
PDNG	Pending	Payment initiation or individual transaction included in the payment initiation is pending. Further checks and status update will be performed.	Sent by any Agent in the payment chain to the previous Agent as an interim status whilst other validations are performed.
RCVD	Received	Payment initiation has been received by the receiving agent.	Sent by Any Agent to the previous Agent as confirmation that their Customer Credit Transfer initiation request has been received by the payment engine.
RJCT	Rejected	Payment initiation or individual transaction included in the payment initiation has been rejected.	Sent by Any Agent to inform the previous Agent that their Customer Credit Transfer has been rejected.

Payment Transaction Status – High Level logical process flow

pain.002

The interbank pain.002 *Customer Payment Transaction Status* element facilitates updates from the *Debtor Agent* to the previous Agent, e.g., the *Forwarding Agent* or the payment originator (the *Debtor/ the Initiating Party*) on changes to the status of the payment. Such Status Information messages (pain.002), with the exception of **reject code RJCT** which **is mandatory in CBPR+**, are bilateral agreed, where upon a variety of these Transaction Statuses may be used by the Instructed Agent at different stages of the payment processing.

This diagram illustrates the logical order in which these codes may be used during the processing of the Payment Initiation messages (pain) and the interbank Payment Clearing And Settlement message (pacs) and the role of the Agents in providing these status.

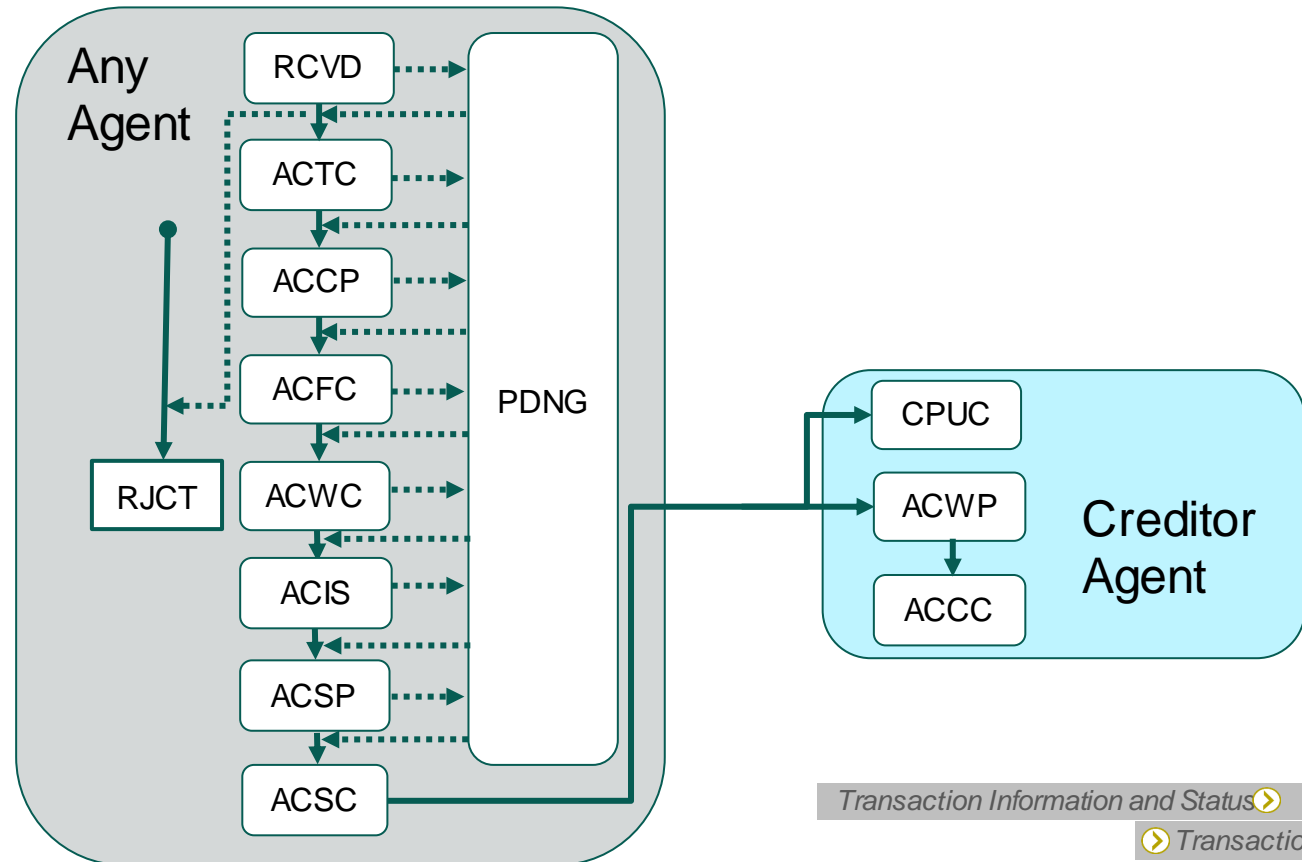

Transaction Information and Status

Transaction Status



Index of pain.002 Use Cases

Use case should be considered as a principal example whereby use case may be cross referenced e.g. a use case involving a Market Infrastructure can apply the Market Infrastructure legs to other use cases.

Interbank Customer Payment Status Report – Relay

Use Case pn.2.1.1 – High Level Payment Initiation Interbank ‘relay’ status report

Use Case pn.2.1.1.a – High Level Payment Initiation Interbank ‘relay’ status report Multi-bank Sweep

Use Case pn.2.1.2 – High Level Payment Initiation Interbank ‘relay’ status report involving a Payment Market Infrastructure

Use Case pn.2.1.3 – High Level Direct Debit Initiation Interbank ‘relay’ status report involving a Payment Market Infrastructure

Interbank Customer Payment Status Report – Authorised Party

Use Case pn.2.2.1 – High Level Payment Initiation Interbank status report for Authorised Party

Use Case pn.2.2.1.a. – High Level Payment Initiation Interbank status report for FI-Initiated Sweep (Long position at the Secondary Account)

Use Case pn.2.2.1.b. – High Level Payment Initiation Interbank status report for Authorised Party to pay themselves as the Creditor.

Interbank Customer Payment Status Report – Financial Institution

Use Case pn.2.3.1 – High Level Payment Initiation Interbank status report for Financial Institution Payment Initiation

Interbank multiple Payment Status Reports

Use Case pn.2.4.1 – High Level Payment Initiation Interbank ‘relay’ multiple status reports

Use Case pn.2.4.2 – High Level Rejection of an incomplete ‘relay’ Payment

Use Case pn.2.4.3 – High Level Direct Debit Initiation Interbank ‘relay’ multiple status reports involving a Payment Market Infrastructure

High Level Payment Initiation Interbank 'relay' status report (pain.002)

In the interbank relay scenario, the Debtor Agent sends the pain.002 message to the Forwarding Agent which relays the same information to the Initiating Party.

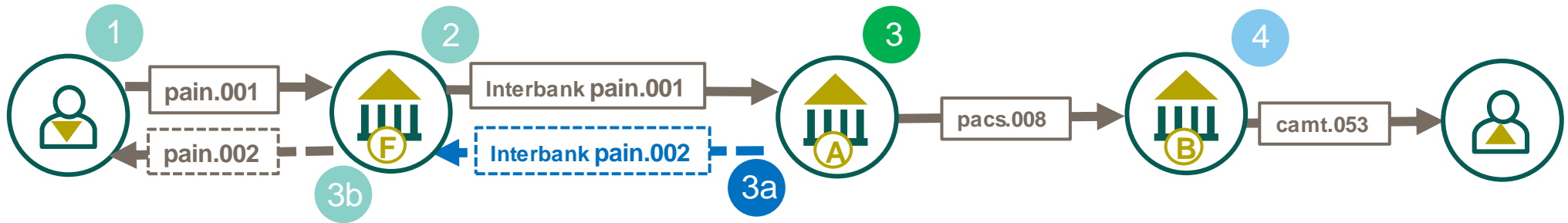

1

Initiating Party sends a payment instruction to the Forwarding Agent

2

Forwarding Agent (F) forwards the payment instruction to the Debtor Agent (A)

3

Debtor Agent (A) debits the account of Debtor and initiates a credit transfer by forwarding a local credit transfer message pacs.008

3a

Debtor Agent (A) provides a status update ACSP (accepted settlement in progress) to the Forwarding Agent (F), based upon a bilateral agreement

3b

Forwarding Agent (F) relays the status ACSP (accepted settlement in progress) to the Initiating Party, based upon a bilateral agreement

4

Creditor Agent (B) receives the credit transfer message, credits the Creditor, and sends a camt.053 (statement) at the end of the business day

High Level Payment Initiation Interbank 'relay' status report (pain.002)

Multi-bank Sweep

In the interbank relay scenario, the Debtor Agent sends the pain.002 message to the Forwarding Agent which relays the same information to the Initiating Party.

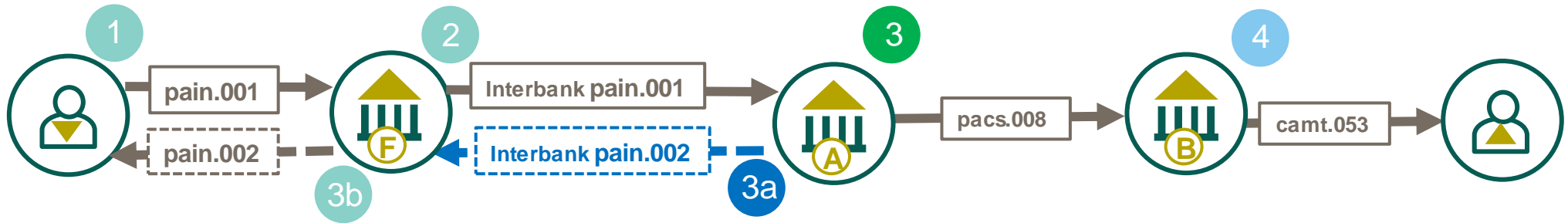

1 Initiating Party sends a payment instruction to the Forwarding Agent to sweep excess funds from its subsidiary's account to the master account with Bank B

2 Forwarding Agent (F) forwards the payment instruction to the Debtor Agent (A)

3 Debtor Agent (A) debits the account of Debtor and initiates a credit transfer by forwarding a local credit transfer message pacs.008

3a Debtor Agent (A) provides a status update ACSP (accepted settlement in progress) to the Forwarding Agent (F), based upon a bilateral agreement

3b Forwarding Agent (F) relays the status ACSP (accepted settlement in progress) to the Initiating Party, based upon a bilateral agreement

4 Creditor Agent (B) receives the credit transfer message, credits the Creditor, and sends a camt.053 (statement) at the end of the business day

High Level Payment Initiation Interbank 'relay' status report (pain.002) involving a Payment Market Infrastructure

In the interbank relay scenario, the Debtor Agent sends the pain.002 message to the Forwarding Agent which relays the same information to the Initiating Party.

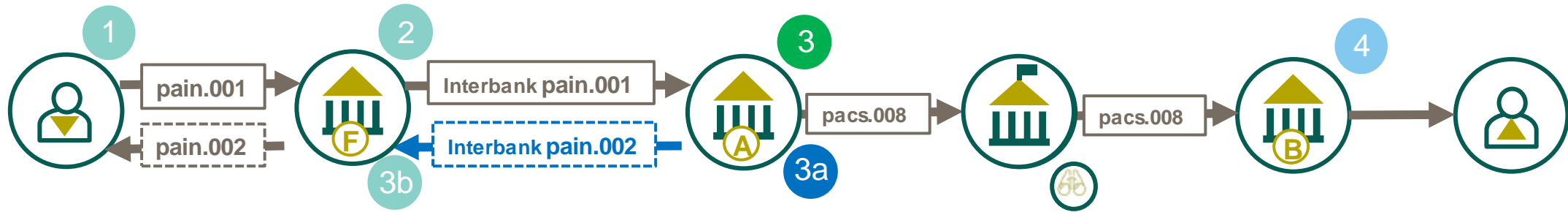

1 Initiating Party sends a payment instruction to the Forwarding Agent

2 Forwarding Agent (F) forwards the payment instruction to the Debtor Agent (A)

3 Debtor Agent (A) debits the account of Debtor and initiates a credit transfer by forwarding a local credit transfer message pacs.008 to a Payment Market Infrastructure (PMI)

3a Debtor Agent (A) provides a status update ACSP (accepted settlement in progress) to the Forwarding Agent (F), based upon a bilateral agreement

3b Forwarding Agent (F) relays the status ACSP (accepted settlement in progress) to the Initiating Party, based upon a bilateral agreement

4 Creditor Agent (B) receives local credit transfer message via the Payment Market Infrastructure and credits the Creditor



High Level Direct Debit Initiation Interbank 'relay' status report (pain.002) involving a Payment Market Infrastructure

In the interbank relay scenario, the Creditor Agent sends the pain.002 message to the Forwarding Agent which relays the same information to the Initiating Party.

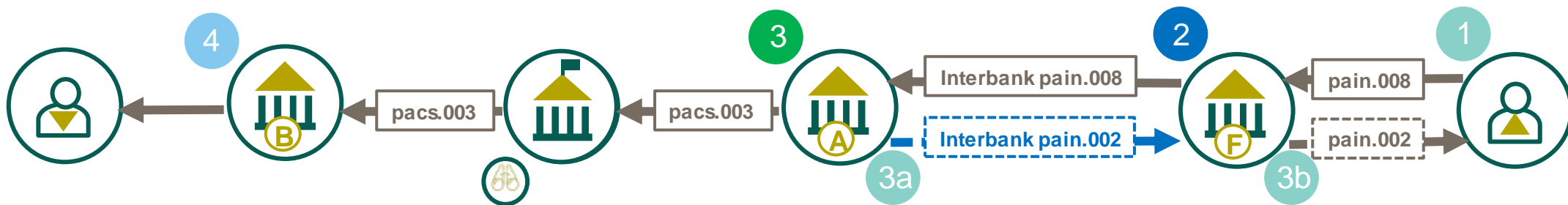

- 1 Initiating Party sends a direct debit instruction to the Forwarding Agent
- 2 Forwarding Agent (F) forwards the payment instruction to the Creditor Agent (A)
- 3 Creditor Agent (A) instructs a direct debit transaction by sending a local direct debit message pacs.003 to a Payment Market Infrastructure
- 3a Creditor Agent (A) provides a status update ACSP (accepted settlement in progress) to the Forwarding Agent (F), based upon a bilateral agreement
- 3b Forwarding Agent (F) relays the status ACSP (accepted settlement in progress) to the Initiating Party, based upon a bilateral agreement
- 4 Debtor Agent (B) receives a local direct debit message via the Payment Market Infrastructure and debits the account of the Debtor



High Level Payment Initiation Interbank status report (pain.002) for Authorised Party

In the scenario Authorised Party Initiation, the Debtor Agent sends the pain.002 message to the Financial Institution which initiated a payment based on Debit Authorisation with the Debtor and the Debtor Agent.

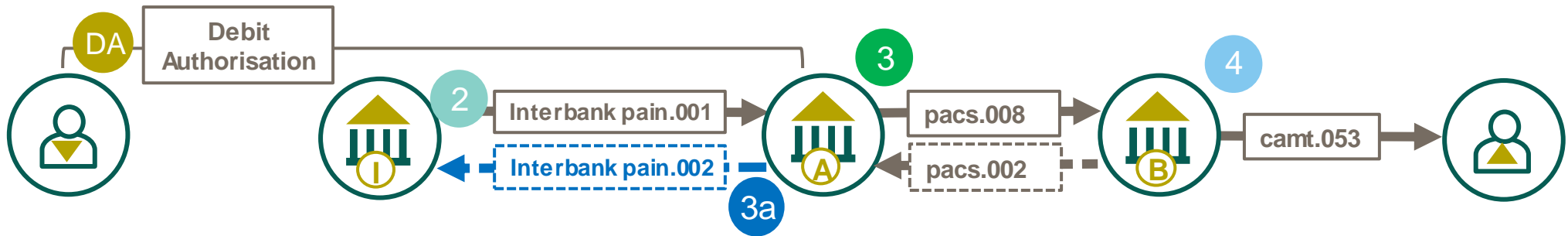

DA As a pre-requisite the Debtor provides Debit Authorisation to Agent I to Initiate Payment from their account with the Debtor Agent (A)

2 Agent (I) initiates a payment request (pain.001) to the Debtor Agent (A) to move fund from the Debtor's account, as an authorised party.

3 Debtor Agent (A) debits the account of Debtor and initiates a credit transfer

3a Debtor Agent (A) optionally provides a status update to the Initiating Party (Agent I), based upon a bilateral agreement

4 Creditor Agent (B) receives credit transfer message, credits the Creditor and optionally provided a status report to Debtor Agent based upon a bilateral agreement. It also sends the result of the sweep by camt.052 (intraday sweep) and or camt.053 (statement) to the Corporate



High Level Payment Initiation Interbank status report (pain.002) for Authorised Party: FI-Initiated Sweep (Long position at the Secondary Account)

In the scenario Authorised Party Initiation, the Debtor Agent sends the pain.002 message to the Financial Institution which initiated a liquidity sweep on behalf of a corporate customer based on the sweep contract

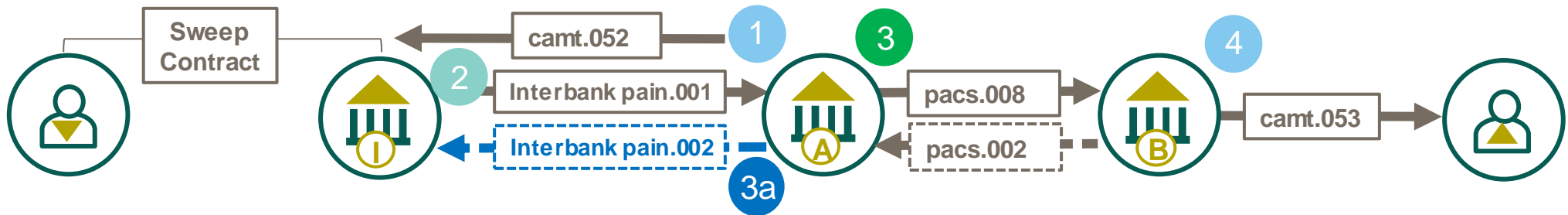

1 Agent I receives intraday balance report from the Debtor Agent (A) on behalf of their mutual customer

2 Agent (I) initiates a sweep on behalf of the Corporate by sending pain.001 to the Debtor Agent

3 Debtor Agent (A) debits the account of Debtor and initiates a credit transfer

3a Debtor Agent (A) optionally provides a status update to the Initiating Party (Agent I), based upon a bilateral agreement

4 Creditor Agent (B) receives credit transfer message, credits the Creditor, and sends a camt.053 (statement) at the end of the business day to the Creditor. An optional status report is sent to the previous Agent based upon a bilateral agreement

 See use case [p.8.1.2](#) for a sweeping contract with a short position

High Level Payment Initiation Interbank status report (pain.002) for Authorised Party to pay themselves as the Creditor

In the scenario Authorised Party Initiation, the Initiating Party (Agent I) initiates a payment from the Debtor's account based on Debit Authorisation already in place to move money to themselves as the Creditor

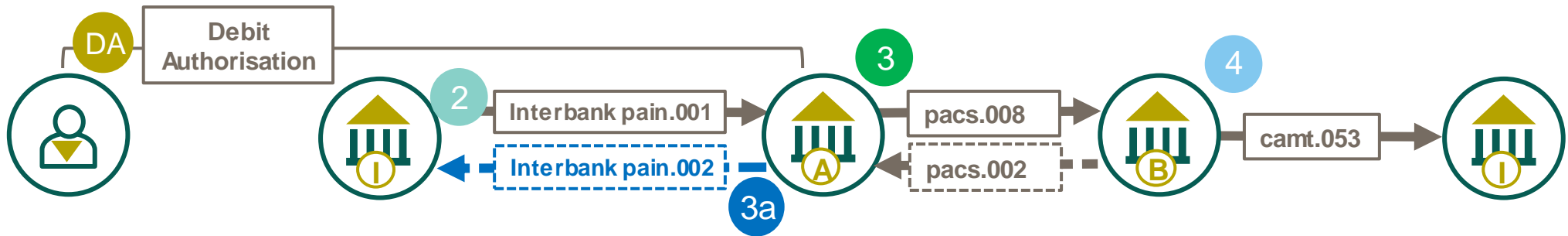

DA
As a pre-requisite the Debtor provides Debit Authorisation to Agent I to Initiate Payment from their account with the Debtor Agent (A)

2
Agent (I) initiates a payment request (pain.001) to the Debtor Agent (A) to move fund from the Debtor's account, as an authorised party, to themselves as the Creditor

3
Debtor Agent (A) debits the account of Debtor and initiates a credit transfer

3a
Debtor Agent (A) optionally provides a status update to the Initiating Party (Agent I), based upon a bilateral agreement

4
Creditor Agent (B) receives the credit transfer message, credits the Creditor, and sends a camt.053 (statement) at the end of the business day to the Creditor. An optional status report is sent to the Debtor Agent based upon a bilateral agreement



High Level Payment Initiation Interbank status report (pain.002) for Financial Institution Payment Initiation

In the scenario Financial Institution Payment Initiation, the Debtor Agent sends the pain.002 message to the Financial Institution which initiated a payment to a non-Financial Institution Creditor using their own account

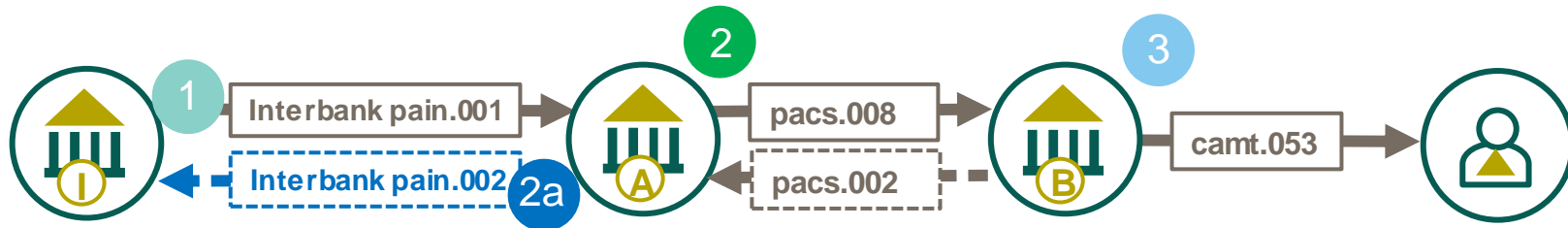

1 Agent (I), the Debtor, initiates a payment request (pain.001) to the Debtor Agent (A) to move funds from their own account

2 Debtor Agent (A) debits the account of Agent (I), the Debtor and initiates a credit transfer

2a Debtor Agent (A) optionally provides a status update to the Initiating Party (Agent I), based upon a bilateral agreement

3 Creditor Agent (B) receives credit transfer message, credits the Creditor, and optionally returns a status report to Debtor Agent based upon a bilateral agreement. It also sends camt.053 (statement) to the non-FI Creditor

High Level Payment Initiation Interbank 'relay' multiple status reports (pain.002)

Use Case pn.2.4.1

In the interbank relay scenario, the Forwarding Agent provides multiple Payment Status Information updates (with different Transaction Status codes) where bilaterally agreed, throughout the payment processing lifecycle.

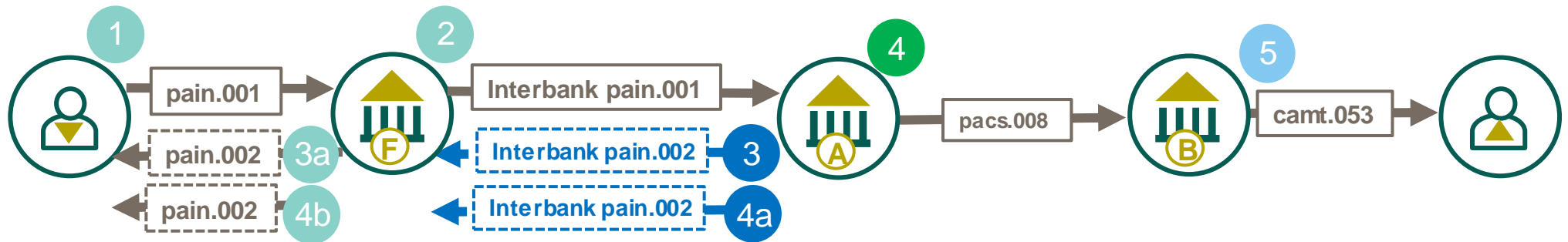

1 Initiating Party sends a payment instruction to the Forwarding Agent

2 Forwarding Agent (F) forwards the payment instruction to the Debtor Agent (A)

3 Debtor Agent (A) optionally provides a status update ACTC (accepted technical validations are successful) to the Forwarding Agent (F), based upon a bilateral agreement.

3a Forwarding Agent (F) relays the status ACTC (accepted technical validations are successful) to the Initiating Party, based upon a bilateral agreement.

4 Debtor Agent (A) processes the payment and sends to the Creditor Agent (B)

4a Debtor Agent (A) optionally provides a further status update ACSP (accepted settlement in progress) to the Forwarding Agent (F), based upon a bilateral agreement.

4b Forwarding Agent (F) relays a further status update ACSP (accepted settlement in progress), to the Initiating Party, based upon a bilateral agreement.

5 Creditor Agent (B) processes the payment and sends the statement to Creditor



High Level Rejection of an incomplete 'relay' Payment (pain.002)

In the interbank relay scenario, the Forwarding Agent provides multiple Payment Status Information updates (with different Transaction Status codes) where bilaterally agreed, throughout the payment processing lifecycle.

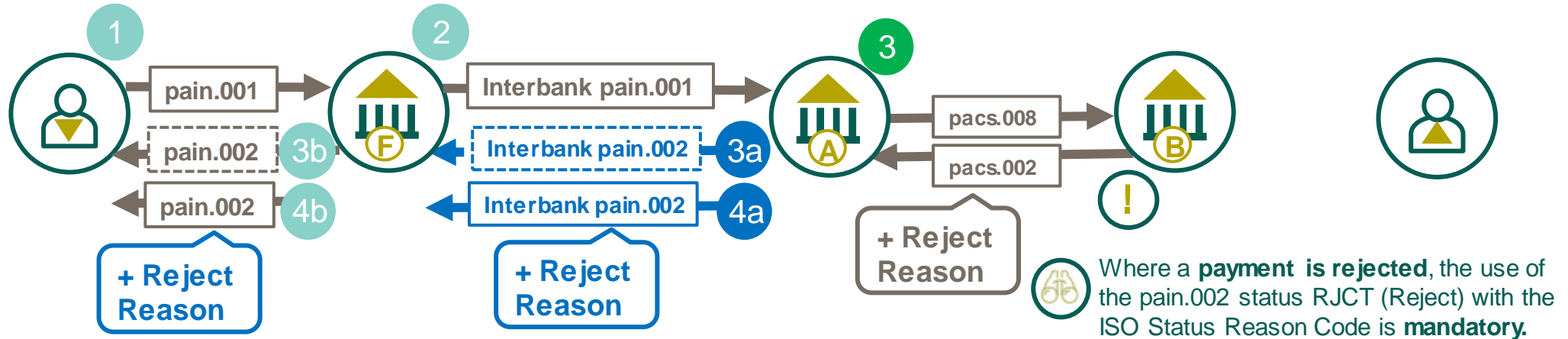

1 Initiating Party sends a payment instruction to the Forwarding Agent

3 Debtor Agent (A) processes the payment and sends to the Creditor Agent (C)

3b Forwarding Agent (F) relays the status ACSP (accepted settlement in progress) to the Initiating Party, based upon a bilateral agreement.

4a Debtor Agent refund the Debtor's account and update the status RJCT with the reason code to the Forwarding Agent

2 Forwarding Agent (F) relays the payment to the Debtor Agent (A)

3a Debtor Agent (A) optionally provides a status update ACSP (accepted settlement in progress) to the Forwarding Agent (F), based upon a bilateral agreement.

! Having received the payment the Creditor Agent recognises the payment cannot be completed e.g., the Creditor's account is closed. Agent B rejects the payment and send pacs.002 to the Debtor Agent

4b Forwarding Agent (F) relays a further status update RJCT with the reason code to the Initiating Party



High Level Direct Debit Initiation Interbank 'relay' multiple status reports (pain.002) involving a Payment Market Infrastructure

In the interbank relay scenario, the Creditor Agent sends multiple status reports to the Forwarding Agent which relays the same information to the Initiating Party.

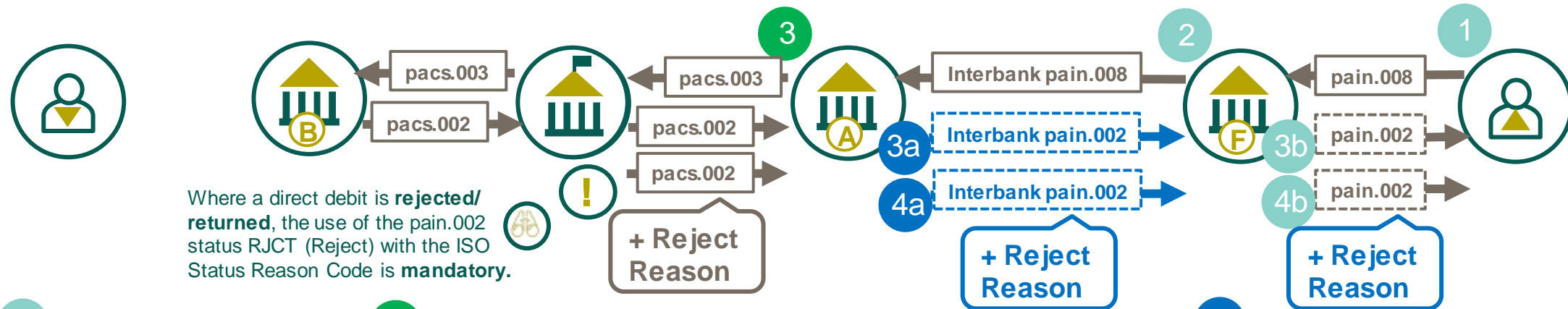

1 Initiating Party sends a direct debit instruction to the Forwarding Agent

2 Forwarding Agent (F) forwards the payment instruction to the Creditor Agent (A)

3 Creditor Agent (A) instructs a direct debit transaction by sending a local direct debit message pacs.003 to a Payment Market Infrastructure (PMI)

3a Creditor Agent (A) provides a status update ACSP (accepted settlement in progress) to the Forwarding Agent (F), based upon a bilateral agreement

3b Forwarding Agent (F) relays the status ACSP (accepted settlement in progress) to the Initiating Party, based upon a bilateral agreement

! Having received the direct debit, PMI recognises the transaction cannot be completed, e.g., insufficient funds in the debtor's account and sends back pacs.002 Reject

4a Creditor Agent update the status RJCT with the reason code to the Forwarding Agent

4 Forwarding Agent (F) relays a further status update RJCT with the reason code to the Initiating Party



pain.008



Interbank Customer Direct Debit Initiation



High level pain.008 comparison with legacy MT 104 Request for Direct Debit



ISO 20022 message element



MT Field Name & (Tag option)

Group Header

- **Message Identification**
- **Initiating Party** – where different from **Creditor**
- **Forwarding Agent**

Payment Information

- **Payment Information Identification**
- **Requested Collection Date**
- **Creditor**
- **Creditor Agent**

Direct Debit Transaction Information

- **Payment Identification**
- **Instructed Amount**
- **Charge Bearer**
- **Mandate Identification**
- **Debtor Agent**
- **Debtor**

Sequence A – General Information:

- **Sender's Reference** (Field 20)
- **Instructing Party** (Field 50 C or L)

Message **Sender** in a 'relay' scenario

Sequence A – General Information:

- **Customer Specified Reference** (Field 21R)
- **Requested Execution Date** (Field 30)
- **Creditor** (Field 50 A or K)*
- **Creditor's Bank** (Field 52 A, C or D)*

Sequence B – Transaction Details:

- **Transaction Reference** (Field 21)
- **Currency and Transaction Amount** (Field 32B)
- **Details of Charges** (Field 71A)
- **Mandate Reference** (Field 21C)
- **Debtor's Bank** (Field 57 A, C or D)
- **Debtor** (Field 59 no letter or A)



pain.008 Interbank Customer Direct Debit Initiation

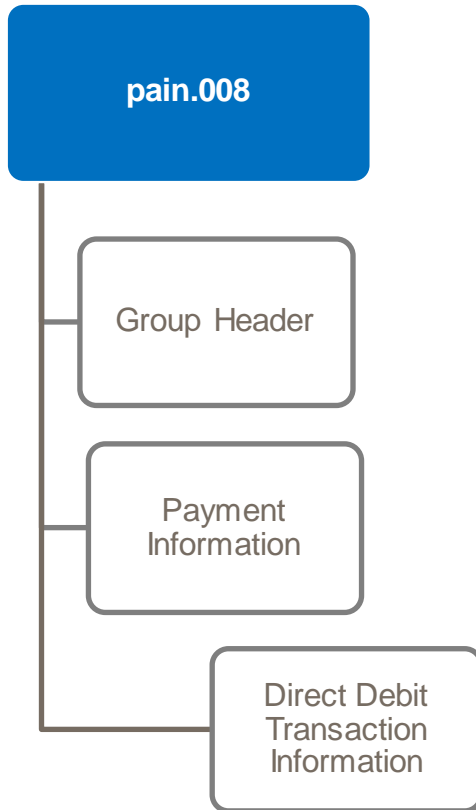

The pain.008 message is composed of three blocks:

- **Group Header** contains a set of characteristics that relates to all individual transaction.
- **Payment Information** contains a set of characteristics that relates to the credit side of the transaction, such as Creditor and Creditor Agent.
- **Direct Debit Transaction Information** contains, among others, elements related to the debit side of the transaction, such as Debtor and Debtor Agent and optionally mandate related information.



Direct Debit Initiation relay messages in a many-to-many space allow for multiple transactions as they will be typically cleared by Automated Clearing House (ACH) batch processing system.

High Level serial message flow: Direct Debit Initiation “Relay”

pain.008

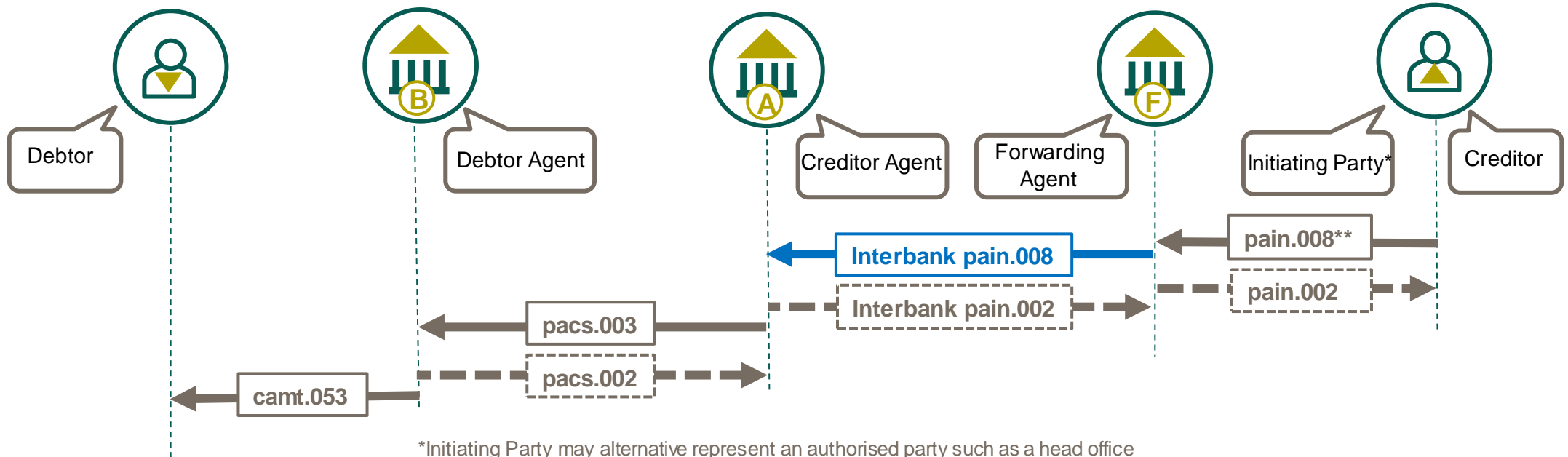

*Initiating Party may alternative represent an authorised party such as a head office
 **or other proprietary method for instructing a direct debit initiation request.

Interbank Customer Direct Debit Initiation message is sent by the Initiating Party to the Forwarding Agent or the Creditor Agent. It is used to request single or bulk collection(s) of funds from one or various debtor’s account(s) to a creditor.

Relay: Interbank pain.008 message is sent by the Initiating party (the Creditor or authorised party) to the Forwarding Agent which acts as a concentrating financial institution. It will forward the pain.008 message to the Creditor Agent to initiate the direct debit instruction(s).



*Noting in CGI-MP pain.008 may also be sent by the Initiating Party/Creditor directly to the Creditor Agent which is outside of the scope of CBPR+.

Group Header





pain.008 Interbank Customer Direct Debit Initiation – Message Identification



Min 1 – Max 1

Each ISO20022 payment message has a **Message Identification** element, located in the Group Header. This **35 character** identifier is a point-to-point reference used to unambiguously identify the message.

For the Payment Initiation (pain) messages the *Message Identification* has no exact equivalent in the legacy MT payment message. However, the Sender's Reference (Field 20) could be considered as a similar comparison where a pain message contains a single Transaction.



Each transaction's *Direct Debit Transaction Information* contains a variety of nested *Payment Identification* elements to capture reference related to the individual transaction such as a UETR (Unique End-to-end Transaction Reference).



For a relay scenario, Forwarding Agent should respect the Message ID provided by the Initiating Party (Creditor or authorized third party) of the pain.008.

Group Header ➤ Message Identification



pain.008 Interbank Customer Direct Debit Initiation – Creation Date Time

Min 1 – Max 1

The pain.008 message **Creation Date Time** captures the date and time which the message was created.

It is defined by **ISO Date Time** with mandatory date and time components expressed in the following formats:

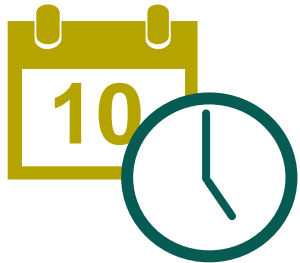

1. Universal Time Coordinated (UTC) time **YYYY-MM-DDThh:mm:ss.sssZ**
2. Local time with UTC offset **YYYY-MM-DDThh:mm:ss.sss+/-hh:mm**
3. Local time format **YYYY-MM-DDThh:mm:ss.sss**



Unlike other CBPR+ messages, the interbank pain.008 message is more flexible in defining the date and time elements. The most recommended representation is Local time with UTC offset which was mandated by CBPR+ (2nd option). Otherwise use UTC time (1st option). Decimal fractions of milliseconds with 3 digits are optional.

pain.008 Interbank Customer Direct Debit Initiation – Authorisation

Min 0 – Max 2

The pain.008 message **Authorisation** allows the Initiating Party to specify if a file requires either File Level or Transaction Level approval by additional security provisions, such as digital signature or user key. The *Authorisation* uses an embedded code set or free text form. It has no equivalent in the legacy MT direct debit message.

Code	Description	Description
ILEV	Instruction Level Authorisation	File requires all customer transactions to be authorised or approved.
FDET	File Level Authorisation Details	Additional file level approval, with the ability to view both the payment information block and supporting transaction detail.
FSUM	File Level Authorisation Summary	Additional file level approval, with the ability to view only the payment information block.
AUTH	Pre Authorised File	File has been pre-authorised or approved within the originating customer environment and no further approval is required.



For single transactions in the CBPR+ usage guidelines, the most applicable code will be ILEV for Instruction Level Authorisation. The use of Authorisation is only allowed when bilaterally agreed.

Group Header ➤ Authorisation





pain.008 Interbank Customer Direct Debit Initiation – Number of Transactions

Min 1 – Max 1

The pain.008 message ***Number of Transactions*** captures the number of individual transaction contained within the message.



Multiple transactions are allowed in CBPR+ direct debit usage guidelines. However, it is recommended to have only one single direct debit transaction unless bilaterally determined.



Single transactions in the CBPR+ direct debit usage guidelines enable a transaction to be managed and unlocks highly automated, frictionless, instant collection, supporting the next generation of innovation.

Group Header ➤ *Number of Transactions*

pain.008 Interbank Customer Direct Debit Initiation – Initiating Party

Min 1 – Max 1

The **Initiating Party** can either be the **Creditor** or an **Authorised Party** who initiates direct debit transactions on behalf of the **Creditor**. The **Initiating Party** can be, for example, the Head Office which is authorised by its subsidiary to request for payment amount to be collected from the **Debtor**. In the centralization model, the **Initiating Party** can also be a payment factory or shared service centre or third party agent, which has authority to send the message on behalf of the **Creditor**.

In the interbank pain.008 ‘Relay’ message use case: The **Initiating Party** sends the pain.008 message to the **Forwarding Agent** which acts as a concentrating financial institution. It will forward the pain.008 message to the **Creditor Agent**.

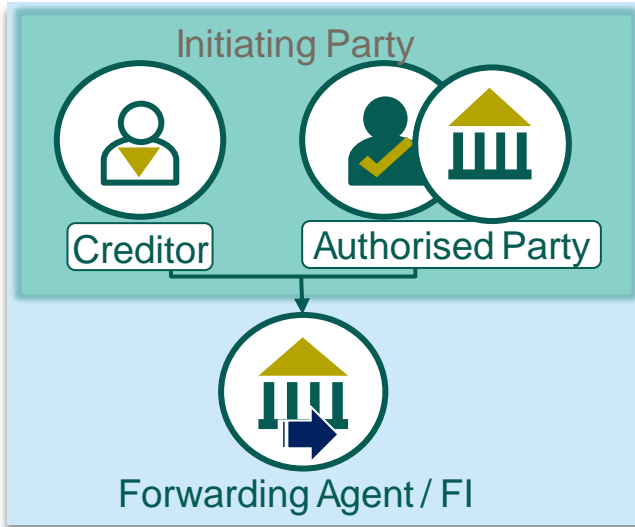

Initiating Party has a mandate (debit authority agreement) to debit the account of the Debtor.



pain.008 Interbank Customer Direct Debit Initiation – Initiating Party

The **Initiating Party** can either be the **Creditor** or an authorised party, such as Financial Institution, in the context of interbank pain.008. Sub elements describe the **Initiating Party** in greater detail.

Mandatory **Name** where Postal Address is provided.

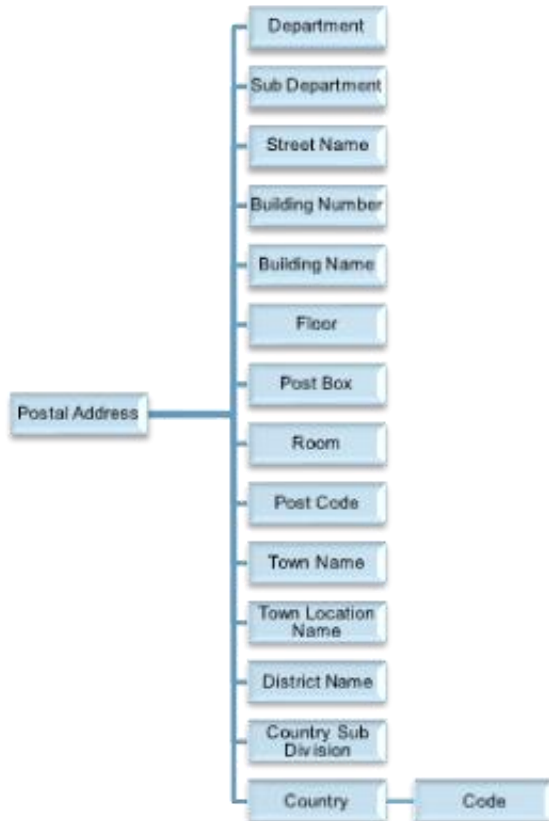

Nested element capturing **structured** Postal Address including at least Town Name and Country if used.

Nested element capturing the various types of identifiers, e.g. BIC, LEI etc.

Optional element to capture the Initiating Party's ISO country code of residence

Optional contact details

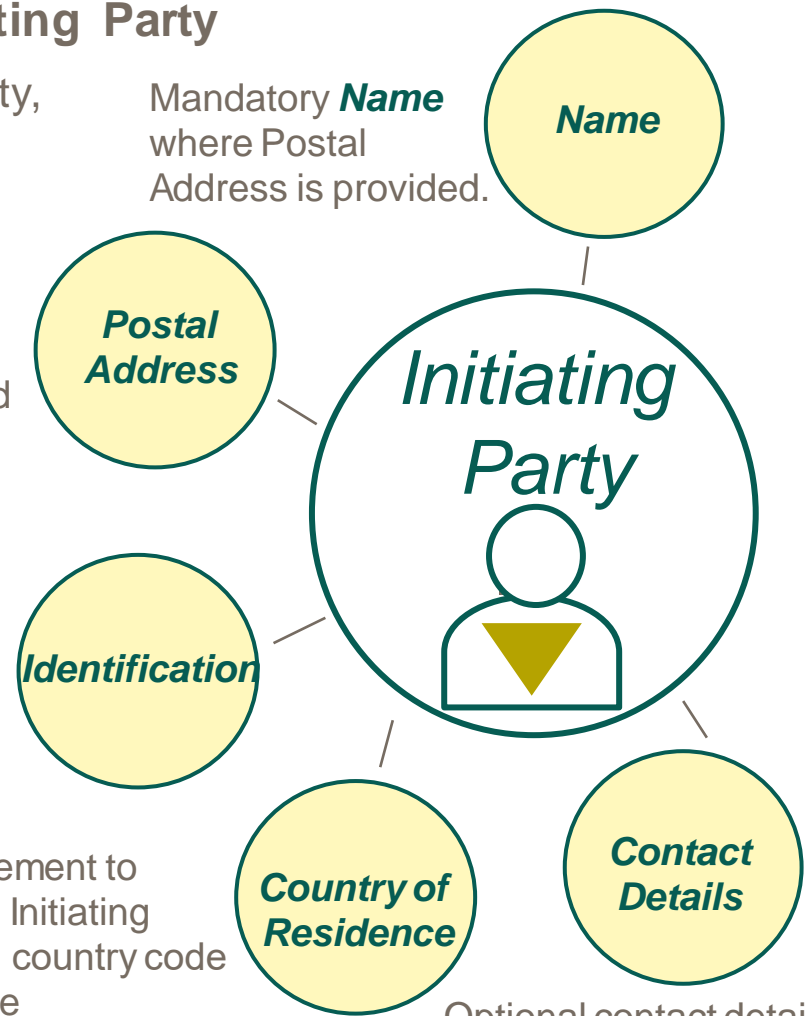



pain.008 Interbank Customer Direct Debit Initiation – Forwarding Agent



Min 1 – Max 1

The **Forwarding Agent** is mandatory in a relay scenario whereby the *Initiating Party* (the *Creditor* or authorised third party) has to provide **Business Identifier Code** (BICFI) of the *Forwarding Agent* in the pain.008 message. The Forwarding Agent acts as a concentrating financial institution and forwards the pain.008 message to the *Creditor Agent* for execution.

Other options to complement the identity of the **Forwarding Agent** include:

- Clearing System Member ID
- LEI (Legal Entity Identifier)

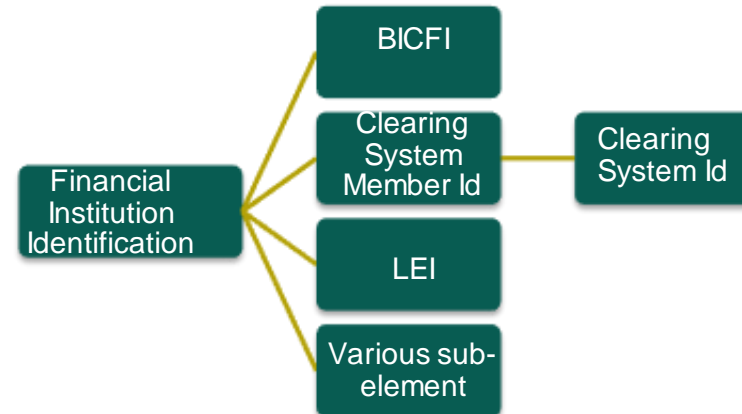

Group Header ➤ Forwarding Agent



Payment Information



Postal Address – Structured versus Unstructured.

The CBPR+ pain.008 Interbank Usage Guideline aligns to the Usage Guideline of CGI-MP, to remain interoperable. It is important to recognise that the CGI Postal Address allows the Postal Address information to be captured as both structured and unstructured (address line) data, of which the Country Code within the Postal Address is mandatory.

As a payment initiation could instruct various types of Payment Methods settled across various Clearing Methods, it should also be recognized that the Usage Guideline specification of those instructions need to be adhered to, which may need some enrichment or repair of the data from the payment initiation message.

Postal Address is a good example of such data enrichment or repair, where many domestic payment methods exclusively support unstructured postal addresses. Likewise, CBPR+ and HVPS+ payments consider structured and unstructured postal addresses to be mutually exclusive. i.e., only one or the other may be used.

CGI-MP payment Initiation/
CBPR+ payment initiation interbank

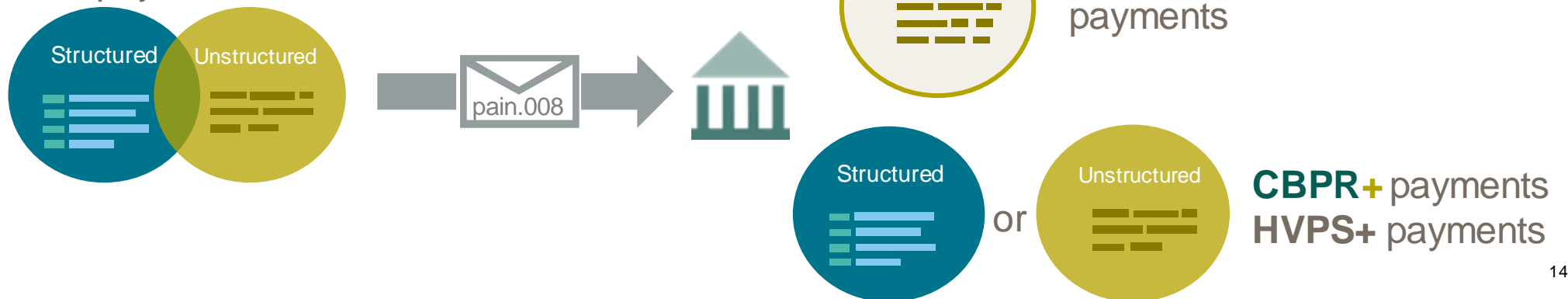

pain.008 Interbank Customer Direct Debit Initiation – Payment Information Identification

Min 1 – Max 1

The Interbank Customer Direct Debit Initiation **Payment Information Identification** provides a mandatory element to identify the payment information group within the message.



This 35 character identifier is a point-to-point reference used to unambiguously identify the payment information group within the message. It is also known as a batch reference number if the message contains multiple transactions.



For a single batch in the CBPR+ usage guidelines, the value in Payment Information Identification is the same as the Message Identification of the Group Header.

Payment Information ➤ Payment Information Identification



pain.008 Interbank Customer Direct Debit Initiation – Payment Method

Min 1 – Max 1

The pain.008 message **Payment Method** specifies the means of payment that will be used to move the amount of money. The payment method code “DD” Direct Debit must be used.

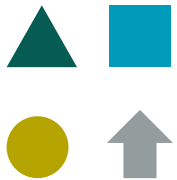

Code	Name	Definition
DD	Direct Debit	Collection of an amount of money from the Debtor's bank account by the Creditor. The amount of money and dates of collections may vary.

pain.008 Interbank Customer Direct Debit Initiation – Batch Booking

Min 0 – Max 1

The pain.008 message **Batch Booking** identifies whether a single entry per individual transaction or a batch entry for the sum of the amounts of all transactions within the group of a message is requested.



Batch booking is used to request for a consolidated credit entry on the Creditor's account. Where this optional element is not used, the default of single credit entries is applied on the Creditor's account.



pain.008 Interbank Customer Direct Debit Initiation – Requested Collection Date

Min 1 – Max 1

The pain.008 message mandatory **Requested Collection Date** element, captures the date at which the creditor requests that the amount of money is to be collected from the debtor.



It is defined by **ISO Date** expressed in the **YYYY-MM-DD format**.



pain.008 Interbank Customer Direct Debit Initiation – Creditor

Min 1 – Max 1

The ISO 2022 pain messages describe the **Creditor** as the party whose account was credited for a transaction. The *Creditor* sub elements describe the *Creditor* in greater detail.

Mandatory **Name** (where a BIC identifier is not provided) by which the party is known

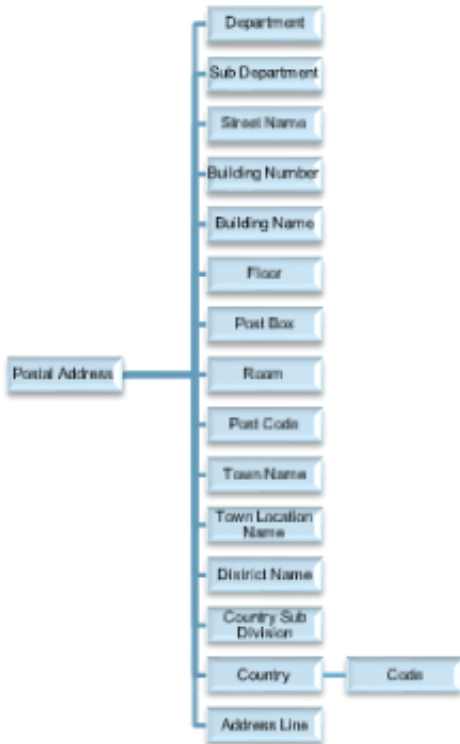

Nested element capturing either structured or unstructured *Creditor* address details.



Note: Structured address is strongly recommended with mandatory Town Name and Country

Nested element capturing the various types of identifiers for the party e.g. BIC, LEI etc.

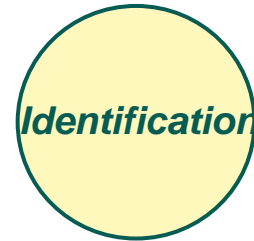

Optional element to capture the *Creditor's* ISO country code of residence

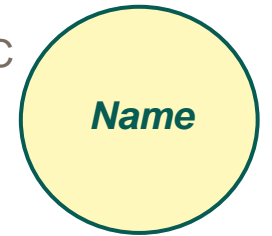

In order to process the pain.008 interbank into a CBPR+ payment, CBPR+ requires either structured or unstructured postal address.



[Take me to an explanation of CGI Postal Address](#)



pain.008 Interbank Customer Direct Debit Initiation – Creditor Account

Min 1 – Max 1

The pain.008 **Creditor Account** is used to capture the account information for which credit entry will be made as a result of the transaction, which will be also reflected in their account Statement.

The **Creditor Account** uses a variety of nested elements to capture information related to the account.



Min 1 – Max 1 Identification identifies the account maintained at the Creditor Agent (Account Servicing Institution)

Min 0 – Max 1 Type uses the external Cash Account Type code list to identify the type of account

Min 0 – Max 1 Currency identifies the currency of the account, recommended.

Min 0 – Max 1 Name identifies the name of the account as assigned by the Creditor Agent (Account Servicing Institution)

Min 0 – Max 1 Proxy captures an alternative identification of the account number such as an email address. This element has further nested **Type** which is a choice of external code list or proprietary code and **Identification** which are both mandatory where the Proxy element is used.



Indication of Currency of the Creditor Account is recommended in case of multi-currency accounts whereby a single account number is allocated to the Creditor Account



pain.008 Interbank Customer Direct Debit Initiation – Creditor Agent

Min 1 – Max 1

The **Creditor Agent** is a static role in the pain.008 Customer Direct Debit Initiation. This agent maintains a relationship with their customers, the **Creditor**.



Note: Although the **Creditor Agent**, **Debtor Agent**, **Creditor** and **Debtor** all maintain static roles in the pain messages, the description of these parties change in the reporting messages (camt) where the Creditor Agent and Debtor Agent become the Statement Account Servicer and the Creditor and the Debtor become the Statement Account Owner. This will be explored further in the camt Cash Management Reporting section.



For Agent Identification, BIC is preferred, alternatively Clearing Member ID together with Name and Address may be provided.

pain.008 Interbank Customer Direct Debit Initiation – Creditor Agent Account

Min 0 – Max 1

The pain.008 **Creditor Agent Account** is used to capture the account information related to the Creditor Agent.

The **Creditor Agent Account** uses a variety of nested elements to capture information related to the account.



Min 1 – Max 1

Identification identifies the account maintained at the Account Servicing Institution

Min 0 – Max 1

Type uses the external Cash Account Type code list to identify the type of account

Min 0 – Max 1

Currency identifies the currency of the account

Min 0 – Max 1

Name identifies the name of the account as assigned by the Account Servicing Institution

Min 0 – Max 1

Proxy captures an alternative identification of the account number such as an email address. This element has further nested **Type** which is a choice of external code list or proprietary code and **Identification** which are both mandatory where the Proxy element is used.



Creditor Agent and Debtor Agent are Financial Institutions, therefore the nested elements **Name** and **Proxy** are unlikely to be used.

pain.008 Interbank Customer Direct Debit Initiation – Charges Account

Min 0 – Max 1

The pain.008 optional **Charges Account** element, which is used to process charges associated with a transaction.

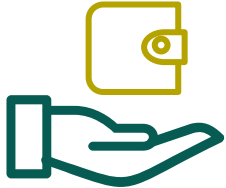

Charges account should be used when charges have to be booked to an account different from the account identified in debtor's account.



This element is not widely used in the payment industry.

pain.008 Interbank Customer Direct Debit Initiation – Charges Account Agent

Min 0 – Max 1

The pain.008 optional **Charges Account Agent** element, which is used to specify the agent that services a charges account.



Charges account agent should only be used when the charges account agent is different from the creditor agent.



This element is not widely used in the payment industry.

Direct Debit Transaction Information



pain.008 Interbank Customer Direct Debit Initiation - Payment Identification

Min 1 – Max 1

The pain.008 message contains **Payment Identification** which provides a set of elements to identify the payment of which several are mandatory elements.

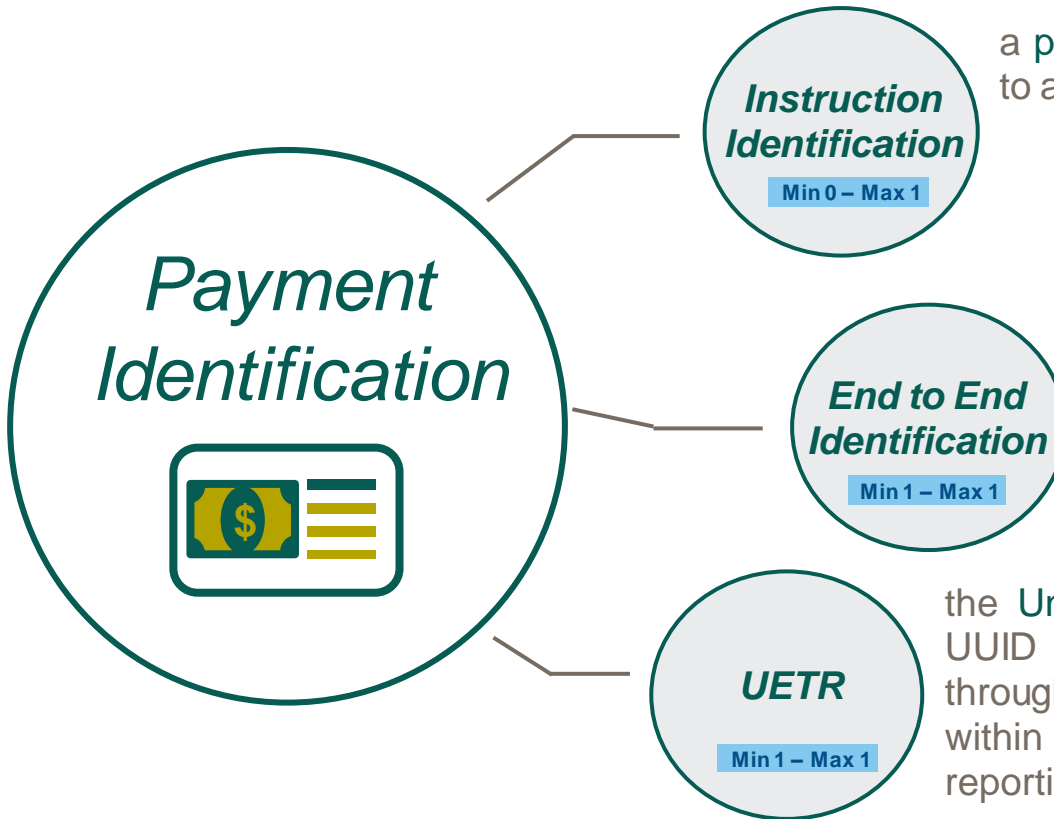

a **point-to-point reference** of 35 characters long will be returned to account statements if provided by the initiating party.



Note: Instruction Id is mandatory in other CBPR+ messages as it maps directly with the mandatory Sender's Reference (Field 20) of the legacy MT payment messages.

an **end-to-end reference** provided by the *Initiating Party* which must be passed unchanged throughout the payment and reported to the *Creditor*.



note: if the Initiating Party has not provided an end-to-end identifier, the *Creditor Agent* may populate "NOTPROVIDED" to comply the mandatory need of this element.

the **Unique End-to-end Transaction Reference** created using the UUID v4 standard. This reference must be passed unchanged throughout the payment, it may also be created by the Creditor within their Payment Initiation request, and also included in reporting messages.

Direct Debit Transfer Transaction Information ✓

➤ Payment Identification

pain.008 Interbank Customer Direct Debit Initiation – Payment Type Information

The pain message **Payment Type Information** provides a set of optional elements where the payment type can be described.

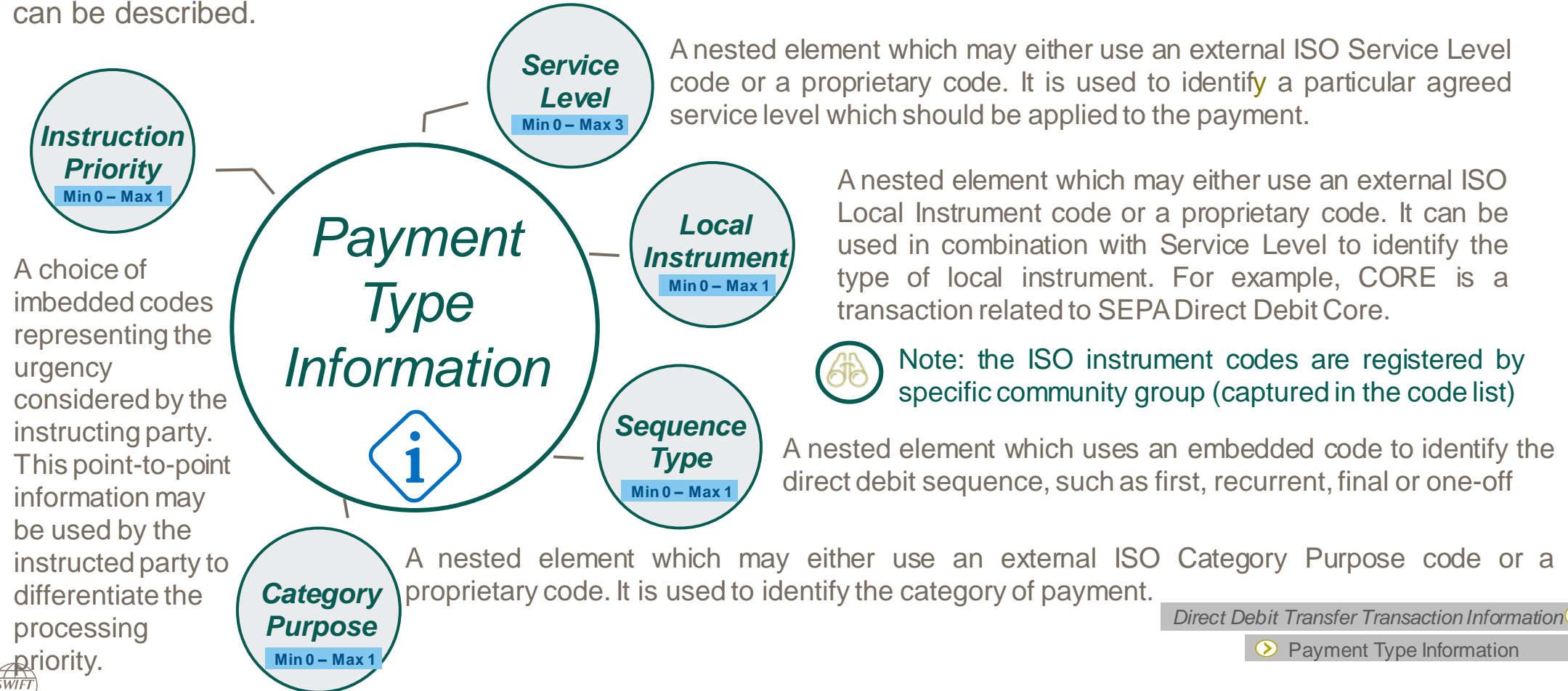



pain.008 Interbank Customer Direct Debit Initiation – Instructed Amount

Min 1 – Max 1

The pain.008 nested **Instructed Amount** element captures the amount of money to be moved between the Debtor and the Creditor before deduction of charges.



Instructed Amount

The **Instructed Amount** captures currency and amount of money to be moved between the Debtor and Creditor, before deduction of charges, expressed in the currency as ordered by the initiating party. This amount has to be transported unchanged through the transaction chain. This element is comparable with both the legacy Field 33B and Field 32B.



For multiple transactions, the currency must be the same for each transaction.



pain.008 Interbank Customer Direct Debit Initiation – Charge Bearer

Min 0 – Max 1

The **Charge Bearer** element exists at the Direct Debit Transaction Information level. It uses an embedded code to specify which party/parties would bear any charges associated with processing the payment transaction. This element is comparable with MT Field 71A ‘Details of Charges’

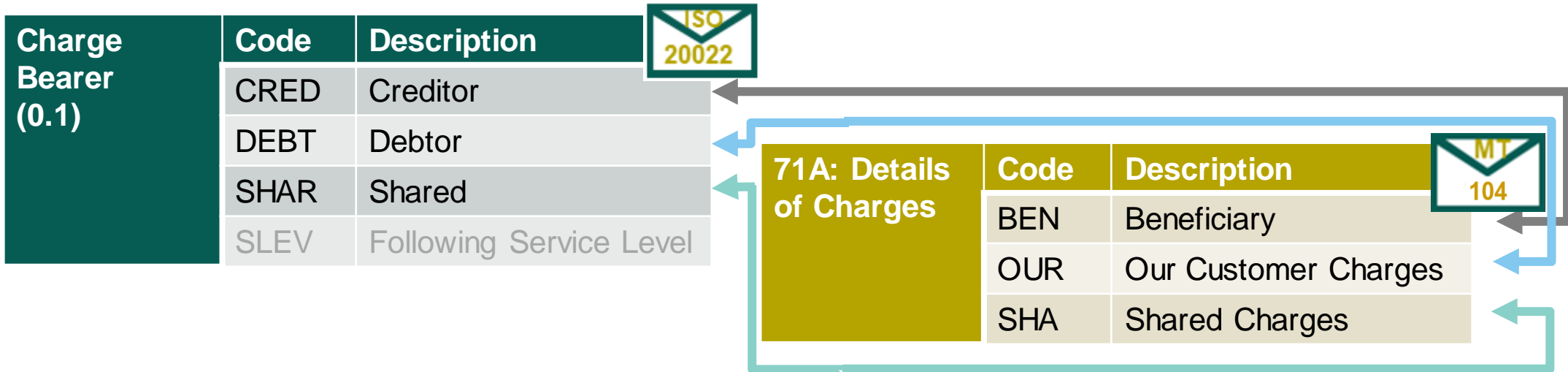

Charge Bearer Code SLEV (Following Service Level) is not allowed in the CBPR+ pain.008 interbank.





pain.008 Interbank Customer Direct Debit Initiation – Direct Debit Transaction

Min 0 – Max 1

The pain.008 **Direct Debit Transaction** component provides information specific to the direct debit mandate.

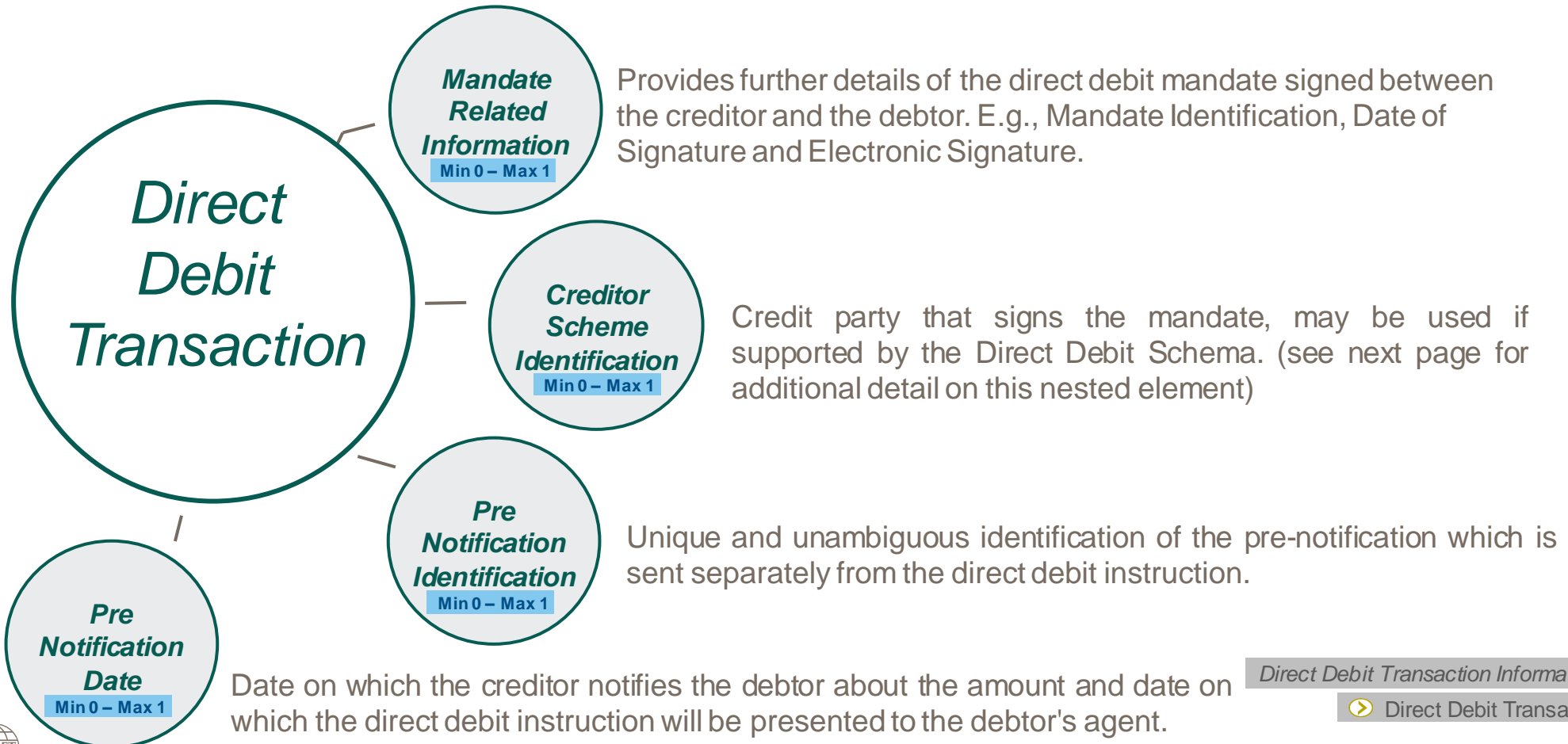

pain.008 Interbank Customer Direct Debit Initiation – Creditor Scheme Identification

Min 0 – Max 1

The **Creditor Scheme Identification** element within the pain.008 message optionally provides information related to the credit party that signs the mandate who is different from the Creditor.



The **Creditor Scheme Identification** element offers the following options:

- Name
- Postal Address: Not used often
- Identification
- Country of Residence
- Contact Details



CGI-MP: recommends the use of Creditor Scheme Identification only if supported by the Direct Debit Scheme.



Direct Debit Transaction Information 

 Direct Debit Transaction

 Creditor Scheme Identification

pain.008 Interbank Customer Direct Debit Initiation – Ultimate Creditor and Ultimate Debtor

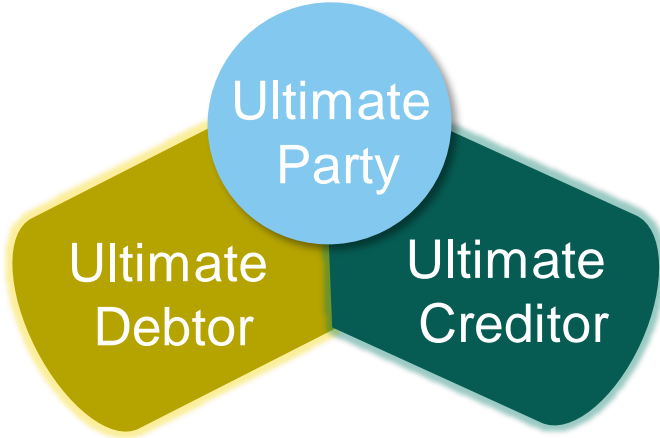

The pain.008 message introduces **Ultimate Creditor** and **Ultimate Debtor**. The **Ultimate Creditor** element should not be confused with an **Initiating Party** who may send a direct debit initiation request on behalf of the **Creditor**, for example, Payment Factory.

CBPR+ premise is that an **Ultimate Creditor** has no financial regulated direct account relationship with the corresponding Creditor. Likewise, an **Ultimate Debtor** has no financial regulated account relationship with the corresponding Debtor.

The **Ultimate Creditor** and **Ultimate Debtor** can be identified by a combination of Name and structured address or Organisation ID (e.g., BIC, LEI), Private ID and Country Of Residence.



In the context of direct debit, **Ultimate Creditor** and **Ultimate Debtor** are not commonly used.

Direct Debit Transaction Information 

 Ultimate Creditor

 Ultimate Debtor

pain.008 Interbank Customer Direct Debit Initiation – Debtor Agent

Min 1 – Max 1

The **Debtor Agent** is a static roles in the pain.008 Customer Direct Debit Initiation. This agent maintain a relationship with their customers, the **Debtor**.



Note: Although the **Debtor Agent**, **Creditor Agent**, **Debtor** and **Creditor** all maintain static roles in the pain messages, the description of these parties change in the reporting messages (camt) where the Debtor Agent and Creditor Agent become the Statement Account Servicer and the Debtor and Creditor become the Statement Account Owner. This will be explored further in the camt Cash Management Reporting section.



For Agent Identification, BIC is preferred, alternatively Clearing Member ID together with Name and Address may be provided.

Direct Debit Transaction Information



Debtor Agent



pain.008 Interbank Customer Direct Debit Initiation – Debtor Agent Account

Min 0 – Max 1

The pain.008 **Debtor Agent Account** is used to capture the account information related to the *Debtor Agent*.

The **Debtor Agent Account** uses a variety of nested elements to capture information related to the account.



Min 1 – Max 1

Identification identifies the account maintained at the Account Servicing Institution

Min 0 – Max 1

Type uses the external Cash Account Type code list to identify the type of account

Min 0 – Max 1

Currency identifies the currency of the account

Min 0 – Max 1

Name identifies the name of the account as assigned by the Account Servicing Institution

Min 0 – Max 1

Proxy captures an alternative identification of the account number such as an email address. This element has further nested **Type** which is a choice of external code list or proprietary code and **Identification** which are both mandatory where the Proxy element is used.



Debtor Agent and Creditor Agent are Financial Institutions, therefore the nested elements **Name** and **Proxy** are unlikely to be used.



Direct Debit Transaction Information



Debtor Agent Account

pain.008 Interbank Customer Direct Debit Initiation – Debtor

Min 1 – Max 1

The ISO 2022 pain messages describes the **Debtor** as the party whose account was debited for a transaction. The *Debtor* sub elements describe the *Debtor* in greater detail.

Name by which the party is known

Note: it is recommended to include the Postal Address together with the Name

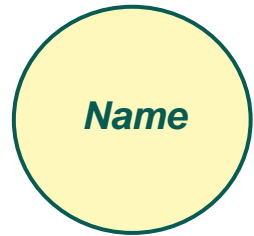

Nested element capturing either structured or unstructured *Debtor* address details.



Note: Structured address is strongly recommended with mandatory Town Name and Country



Nested element capturing the various types of identifiers for the party e.g. BIC, LEI etc.



Optional element to capture the *Debtor's* ISO country code of residence

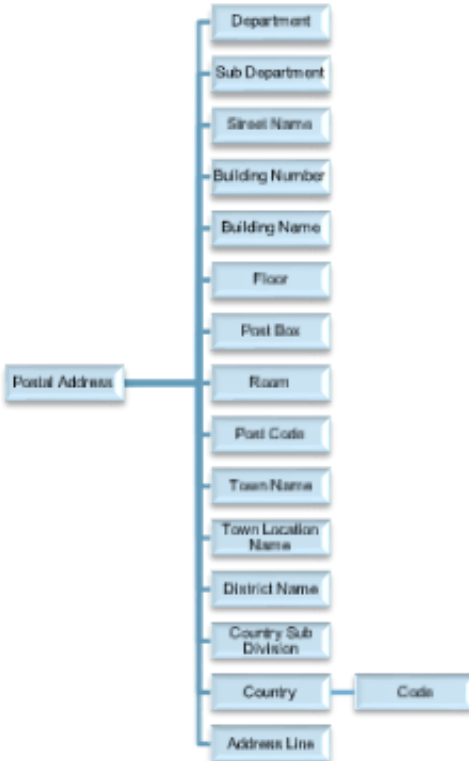

In order to process the pain.008 interbank into a CBPR+ payment, CBPR+ requires either structured or unstructured postal address.



[Take me to an explanation of CGI Postal Address](#)



pain.008 Interbank Customer Direct Debit Initiation – Debtor Account

Min 1 – Max 1

The pain.008 **Debtor Account** is used to capture the account information for which credit entry will be made as a result of the transaction, which will be also reflected in their account Statement.

The **Debtor Account** uses a variety of nested elements to capture information related to the account.



Min 1 – Max 1 Identification identifies the account maintained at the Creditor Agent (Account Servicing Institution)

Min 0 – Max 1 Type uses the external Cash Account Type code list to identify the type of account

Min 0 – Max 1 Currency identifies the currency of the account

Min 0 – Max 1 Name identifies the name of the account as assigned by the Creditor Agent (Account Servicing Institution)

Min 0 – Max 1 Proxy captures an alternative identification of the account number such as an email address. This element has further nested **Type** which is a choice of external code list or proprietary code and **Identification** which are both mandatory where the Proxy element is used.

Direct Debit Transaction Information

Debtor Account



pain.008 Interbank Customer Direct Debit Initiation – Ultimate Debtor

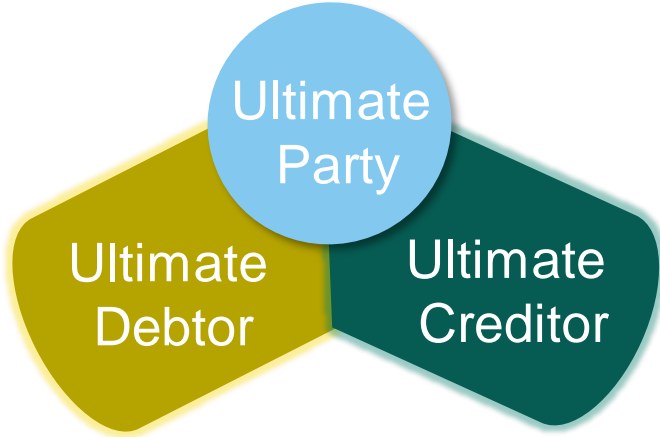

The pain.008 message introduces **Ultimate Debtor** and **Ultimate Creditor**. The **Ultimate Debtor** element should not be confused with an **Initiating Party** who may send a payment initiation request on behalf of the **Debtor**, for example, Payment Factory.

CBPR+ premise is that an **Ultimate Debtor** has no financial regulated direct account relationship with the corresponding Debtor. Likewise, an **Ultimate Creditor** has no financial regulated account relationship with the corresponding Creditor.

The **Ultimate Debtor** and **Ultimate Creditor** can be identified by a combination of Name and structured address or Organisation ID (e.g., BIC, LEI), Private ID and Country Of Residence.



In the context of direct debit, Ultimate Creditor and Ultimate Debtor are not commonly used.

Direct Debit Transaction Information



Ultimate Creditor

pain.008 Interbank Customer Direct Debit Initiation – Instruction For Creditor Agent

Min 0 – Max 1

The ***Instruction for Creditor Agent*** element within the pain.008 message optionally provides information related to the processing of the direct debit.



The ***Instruction for Creditor Agent*** element offers a maximum of 140 characters to provide further information related to the processing of the direct debit instruction, that may need to be acted upon by the *Creditor Agent*, depending on bilateral agreement.

Direct Debit Transaction Information



Instruction for Creditor Agent

pain.008 Interbank Customer Direct Debit Initiation – Purpose

Min 0 – Max 1

The **Purpose** element within the pain.008 message captures the reason for the payment transaction which may either use an external ISO **Purpose code** or a proprietary code.

The purpose is used to capture the nature of the payment, e.g., **IVPT** Invoice Payment, **FEES** Payment of Fees etc. and should not be confused with Regulatory Reporting codes. By definition this information is typically defined by the *Debtor*.



The externalised Purpose code set is classified by the purpose, for example commercial, for which the numerous codes within the classification are each described by Name and Definition. For example, **LOAR** is classified within the Finance categorisation, with the *Name* Loan Repayment described as a repayment of loan to lender.



Category Purpose also captures a high level purpose, which unlike **Purpose** is less granular but can trigger special processing e.g. **Category Purpose** code RPRE ‘Represented’ may trigger a representation of previously reversed or returned direct debit transactions.

Direct Debit Transaction Information 

 Purpose

pain.008 Interbank Customer Direct Debit Initiation – Regulatory Reporting

Min 0 – Max 10

The **Regulatory Reporting** block within the pain.008 message is nested to capture regulatory and statutory information needed to report to the appropriate authority/s.

Min 0 – Max 1

The **Debit Credit Reporting Indicator** utilises an embedded choice of code to indicate whether the regulatory reporting applies to the:

- DEBT (debit)
- CRED (credit)
- BOTH

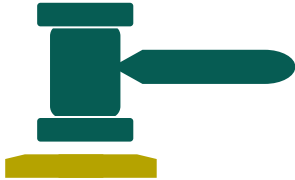

Min 0 – Max 1

The **Authority** element captures the **Name** and **Country** code of the Authority/Entity requiring the regulatory reporting information.

Min 0 – Max *

The **Details** element provides the detail on the regulatory reporting information.



For the purpose of direct debit, **Regulatory Reporting** is not commonly used.

Direct Debit Transaction Information > Regulatory Reporting ✓

⊗ Debit Credit Reporting Indicator

> Authority

> Details

pain.008 Interbank Customer Direct Debit Initiation – Tax

Min 0 – Max 1

The pain.008 nested **Tax** element captures information related to tax. The tax information block is applicable when tax information is used by the clearing or the local regulatory authority(s).

This element caters for two main types of tax related payments:

- Tax payment obligation that is required to be transmitted with a payment
- Information that accompanies an actual payment of a tax obligation

The follow nested elements may be used to capture detailed tax information:

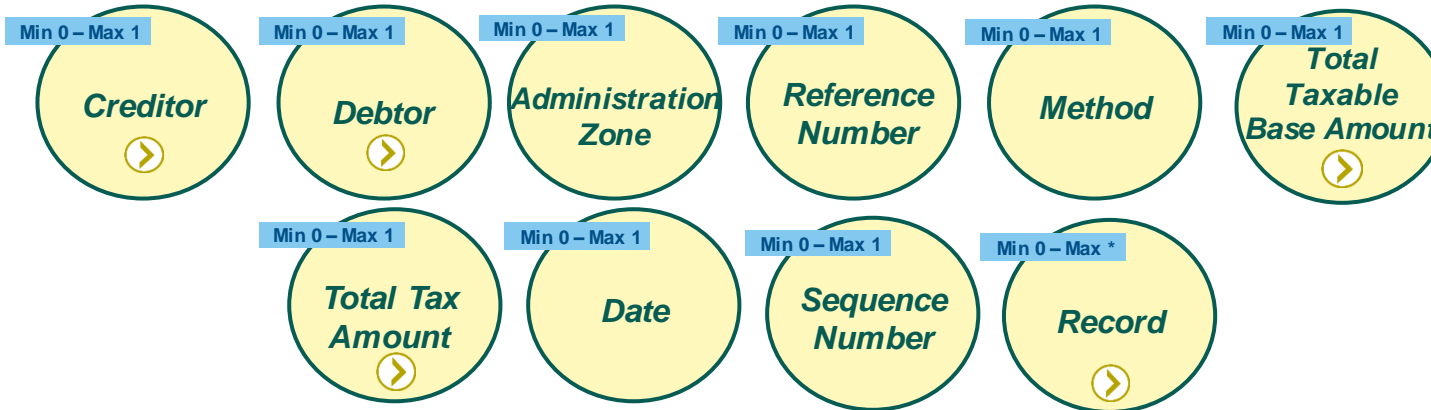

Tax information block is also available within the Structured Remittance Information block which is applicable when tax information is used by the creditor as part of remittance information. Tax Information is not commonly used.

Direct Debit Transaction Information

Tax

pain.008 Interbank Customer Direct Debit Initiation – Related Remittance Information

Min 0 – Max 10

The **Related Remittance Information** element within the pain.008 message is nested to provide information related to the handling of remittance information.

Min 0 – Max 1

The **Remittance Identification** captures a unique reference assigned by the initiating party of the direct debit to identify the remittance information sent separately from the direct debit instruction.

Min 0 – Max *

The **Remittance Location Details** uses a set of nested elements to provide information on either the location of or the delivery of remittance information.

- **Method** requires a code from an embedded list to detail the method used to deliver the remittance advise information e.g. EMAL (email)
- **Electronic Address** provides an electronic address for which an agent is to send the remittance information to e.g. the email address. It may also reference a URL where remittance information maybe deposited or retrieved.
- **Postal Address** provides the postal address to which an agent is to send the remittance information



Unlike CBPR+ pacs messages, in the interbank pain.008 message, Related Remittance Information and Remittance Information are non-mutually exclusive due to a corporate use case of populating both information blocks for detailing remittance advices which are part of value-added service offered by the *Creditor Agent*.

Direct Debit Transaction Information ✓

➤ Related Remittance Information

pain.008 Customer Direct Debit Initiation – Remittance Information

Min 0 – Max 1

The optional **Remittance Information** element within the pain.008 message is nested to provide either **Structured** or **Unstructured** information related to payment, such as invoices.

Remittance Information enables the matching/reconciliation of an entry that the payment is intended to settle.

Min 0 – Max 1

The **Unstructured** sub element captures free format *Remittance Information* which is restricted in interbank CBPR+ to 140 characters to ensure backward compatibility with the legacy MT message during coexistence.



Min 0 – Max *

The **Structured** element is nested capturing rich structured *Remittance Information*, and is unlimited in its multiplicity, but must not exceed 9,000 characters of business information (does not include the xml element identification)

The use of this nested element should be bilaterally/multilaterally agreed, to ensure end-to-end transportation of this data.

Direct Debit Transaction Information

Remittance Information

Structured

Unstructured



pain.008 Interbank Customer Direct Debit Initiation – Structured Remittance Information

The bilaterally/multilaterally agreed **Remittance Information** which is **Structured** must not exceed 9,000 characters of business content (i.e. the information). This nested element is used to capture a variety of structured remittance information.

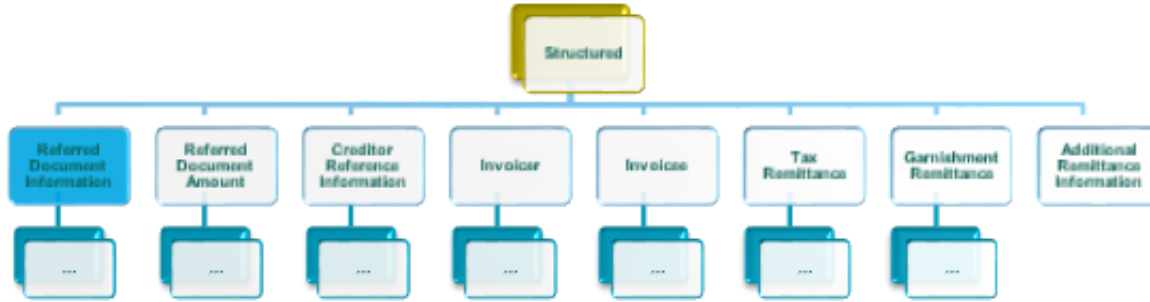

example of *Structured* invoice information

The **Creditor Remittance Information** is provided by the **Creditor** in the Cash Management Reporting messages' Remittance Information component, for example, the camt.053 Bank to Customer Statement.

Structured		<Strd>
Reference Document Information	<RfrdDocInf>	<div style="border: 1px solid black; padding: 5px; display: inline-block;"> CINV A0000101 2019-10-29 </div>
Type	<Tp>	
Code Or Proprietary	<CdOrPrtry>	
Code	<Cd>	
Number	<Nb>	
Related Date	<Dt>	

Annotations: 'element names' points to the left column; 'xml tag' points to the right column; 'business information' points to the nested data box.



In this example Referred Document Information and its nested elements have multiplicity which support up to 9,000 character of information. Whereby this element can be repeated to include more coded information such as another invoice.

- Direct Debit Transaction Information
- Remittance Information
- Structured

pain.008 Interbank Customer Direct Debit Initiation – Structured Remittance Information

The **Creditor Reference** in the *Creditor Reference Information* component in the structured remittance information is generated by *Creditor* to allow for the identification of the underlying documents and enable reconciliation by the Creditor upon receipt of the amount of money.

Creditor Reference in the Structured Remittance Information can be based on ISO 11649

- 2 letters “RF”
- 2 digits check digit
- 21 letters/digits creditor reference

By providing the Creditor Reference in the pain.008, such as invoice number for collection, it will facilitate STP and auto-match the incoming credit entry. The Creditor Reference can be extracted from the statement (e.g., camt.053 Structured Remittance information within the Transaction Details or MT 940 Field 61 or Field 86).

Equally the End-To-End Identification could perform a similar function



SCORE Guideline: For Creditor Reference information, in instances where the Creditor Reference Type code is SCOR (Structured Communication Reference) and the Creditor Reference is structured in accordance with ISO 11649, the Issuer should be specified with the text ‘ISO’ (without the quote marks)



Direct Debit Transaction Information	✓
Remittance Information	▶
Structured	▶

Index of pain.008 Use Cases

Use case should be considered as a principle example whereby use case may be cross referenced e.g. a use case involving a Market Infrastructure can apply the Market Infrastructure legs to other use cases.

Interbank Customer Direct Debit Initiation - Relay

Use Case pn.8.1.1 – High Level Direct Debit Initiation Interbank 'relay' (pain.008)

Use Case pn.8.1.2 – High Level Direct Debit Initiation Interbank 'relay' (pain.008) involving a Payment Market Infrastructure

High Level Direct Debit Initiation Interbank 'relay' (pain.008)

In the interbank relay scenario, the Forwarding Agent relays the pain.008 message to the Creditor Agent to request the collections of funds from the debtor's accounts for a creditor.

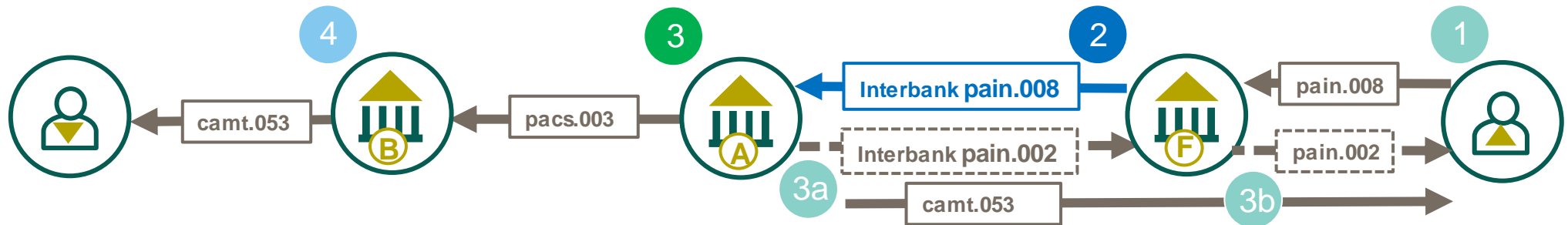

1 Initiating Party sends a direct debit instruction to the Forwarding Agent

2 Forwarding Agent (F) forwards the direct debit instruction to the Creditor Agent (A)

3 Creditor Agent (A) instructs Debtor Agent (B) to perform a direct debit transaction by sending a local direct debit message or pacs.003

3a Creditor Agent (A) provides a status update ACSP (accepted settlement in progress) to the Forwarding Agent (F), based upon a bilateral agreement

3b Forwarding Agent (F) relays the status ACSP (accepted settlement in progress) to the Initiating Party, based upon a bilateral agreement

4 Debtor Agent (B) processes the direct debit and sends the statement to Debtor

High Level Direct Debit Initiation Interbank 'relay' (pain.008) involving a Payment Market Infrastructure

In the interbank relay scenario, the Forwarding Agent relays the pain.008 message to the Creditor Agent to request the collection of funds from the debtor's accounts for a creditor (through a Payment Market Infrastructure).

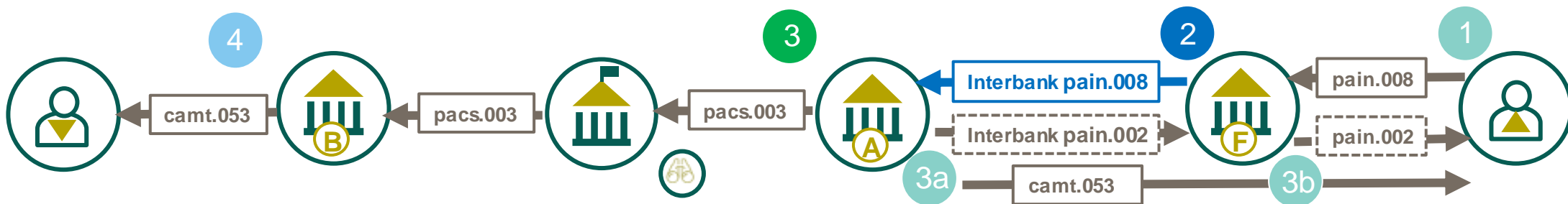

1 Initiating Party sends a direct debit instruction to the Forwarding Agent

3 Creditor Agent (A) instructs a direct debit transaction by sending a local direct debit message or pacs.003 to a Payment Market Infrastructure

3b Forwarding Agent (F) relays the status ACSP (accepted settlement in progress) to the Initiating Party, based upon a bilateral agreement

2 Forwarding Agent (F) forwards the payment instruction to the Creditor Agent (A)

3a Creditor Agent (A) provides a status update ACSP (accepted settlement in progress) to the Forwarding Agent (F), based upon a bilateral agreement

4 Debtor Agent (B) receives a local direct debit message via the Payment Market Infrastructure (PMI) and debits the account of the Debtor



Payment, Clearing and Settlement (pacs) messages



Payment, Clearing and Settlement - Messages index



Payments

[pacs.008 - Financial Institution to Financial Institution Customer Credit Transfer](#)

[pacs.009 - Financial Institution Credit Transfer](#)

[pacs.009 \(cov\) - Financial Institution 'Cover' Credit Transfer](#)

[pacs.009 \(adv\) – Financial Institution 'advice' of Credit Transfer](#)

Payment Rejection and Return

[pacs.002 – Financial Institution To Financial Institution Payment Status Report](#)

[pacs.004 – Payment Return](#)

Direct Debit Payments

[pacs.010 - Interbank Direct Debit](#)

[pacs.010 \(col\) - Interbank Direct Debit Margin Collection](#)

[pacs.003 - Financial Institution to Financial Institution Customer Direct Debit](#)



pacs.008

Financial Institution to Financial Institution Customer Credit Transfer



pac.008 FI to FI Customer Credit Transfer

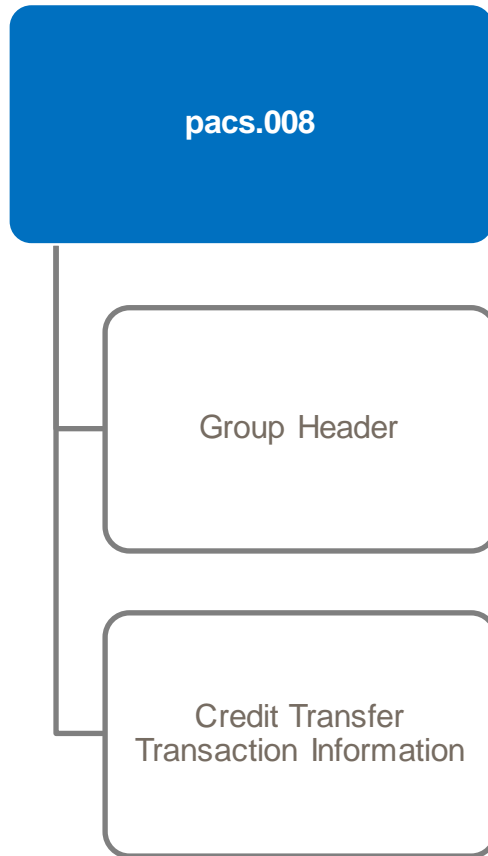

The pac.008 has two core sets of nested elements:

- **Group Header** which contains a set of characteristics that relates to all individual transaction
- **Credit Transfer Transaction Information** which contains elements providing information specific to the individual credit transfer transaction.



Payment messages in a many-to-many payment are considered as a single transaction.

High Level serial message flow

pac.s.008

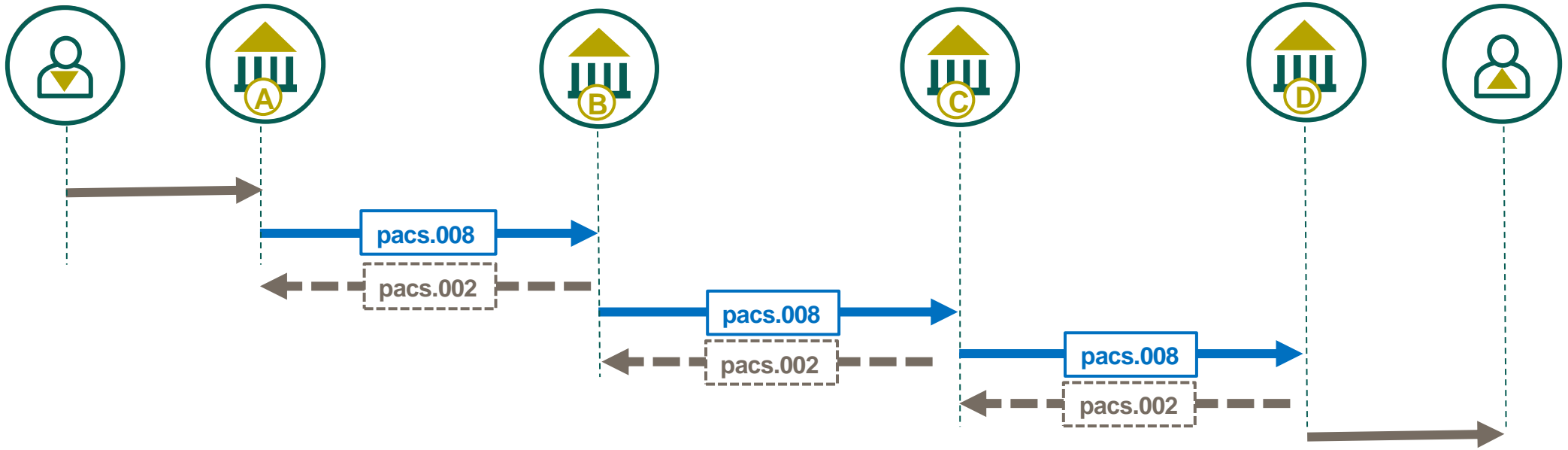

The Financial Institution To Financial Institution Customer Credit Transfer message is sent by the Debtor Agent to the Creditor Agent, directly or through other agents and/or a payment clearing and settlement system. It is used to move funds from a Debtor account to a Creditor, whereby one or both of these Parties are non-Financial Institutions.



Group Header



pac008 FI to FI Customer Credit Transfer - Message Identification

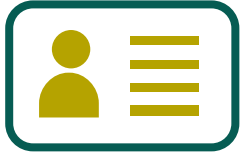

Min 1 – Max 1

Each ISO 20022 payment message has a **Message Identification** element, located in the Group Header. This **35 character** identifier is a point-to-point reference used to unambiguously identify the message.

For Payment Clearing and Settlement (pac0) messages the Message Identification has no exact equivalent in the legacy MT payment message. However, the Sender's Reference (Field 20) could be considered a similar comparison where a pac0 message contains a single Transaction.



Each transaction's *Credit Transfer Transaction Information* contains a variety of nested *Payment Identification* elements to capture reference related to the individual transaction such as a UETR (Unique End-to-end Transaction Reference)

Group Header → Message Identification

pac.008 FI to FI Customer Credit Transfer – Creation DateTime

Min 1 – Max 1

The pac.008 message **Creation Date** captures the date and time which the message was created.

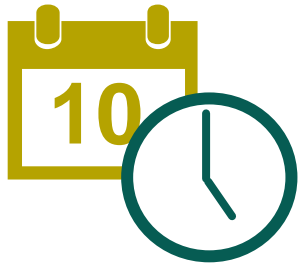

CBPR+ usage guidelines mandate the time zone that the time represents as an offset against Universal Time Coordinated (UTC):

Local time with UTC offset `YYYY-MM-DDThh:mm:ss.sss+/-hh:mm`

- For example: `2002-10-10T12:00:00-05:00` (noon/midday on 10 October 2002, Central Daylight Savings Time as well as Eastern Standard Time in the U.S.)



All CBPR+ time elements need offset against UTC. Milliseconds are optional.

Group Header ➤ Creation Date Time

pac.008 FI to FI Customer Credit Transfer - Number of Transactions

Min 1 – Max 1

The pac.008 message ***Number of Transactions*** captures the number of individual transaction contained within the message.



The number of transactions in CBPR+ payment usage guidelines is fixed to 1.



Single transactions in the CBPR+ payment usage guidelines enable a transaction to be managed and unlocks highly automated, frictionless, instant payments, supporting the next generation of innovation.

Group Header ➤ *Number of Transactions*

pac.008 FI to FI Customer Credit Transfer – Settlement Information

Min 1 – Max 1

The pac.008 **Settlement Method** element within the Group Header **Settlement Information**, includes one of the embedded codes to indicate how the payment message will be settled.

The **Settlement Method** element in the pac.008 allows a choice of an embedded code.

COVE indicate this Customer Credit Transfer will be settlement using a covering pac.009 (COV). The Agents being used in the covering payment to reimburse the Instructed Agent can be provided in the dedicated Reimbursement Agent elements. This allows the Instructed Agent to identify the debit account on their books from the Reimbursement Agent account or look up the account related to the reimbursement agent.



INDA indicate this Customer Credit Transfer will be settlement by the Instructed Agent (as the Account Servicing Institution) The account held at the Instructed Agent may captured in the dedicated **Settlement Account** element.

INGA indicate this Customer Credit Transfer has already been settlement by the Instructing Agent, who has credited the Account they service for the Instructed Agent (as an Account Owner). The account held by the Instructed Agent with the Instructing Agent may captured in the dedicated **Settlement Account** element.



Settlement Method code CLRG is not part of CBPR+ specifications but instead used in Market Infrastructure specification (HVPS+)

pac Settlement Method - explained

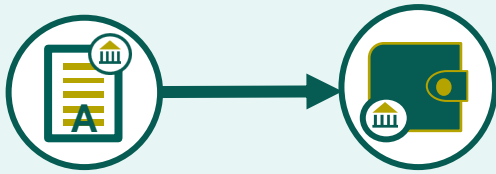

The pacs messages introduce the **Settlement Method** element within the Group Header **Settlement Information**. Settlement refers to the Agent whose role is to act as an Account Servicing Institution i.e. owns the account and provides service to the customer (Account Owner).

The Account Owner can be an Agent or another Party.

Traditionally an interbank account relationship may have been referred to as a Nostro/Vostro relationship or an Agent's account held on another Agent's books/ another Agent's account held on my books.

Typically the commonality of this can be simplified to the Agent who provides the official Account statement is servicing the account and therefore is the Agent responsible for performing the settlement.

Why is it so important to understand which Agent Services the account ?

In ISO 20022, much like the legacy FIN process, each leg of a payment has a settlement component. Commonly one of these settlement legs occurs over a Market Infrastructure, who typically owns or instructs the settlement between the two Market Infrastructure participant Agents at a national Central Bank. In this case the Central Bank services both the Instructing Agent and Instructed Agent accounts which is represented by **CLRG** in the Settlement Method of a pacs message.

In a number of business Use Cases there are examples of additional legs, which may occur prior to or after a potential Market Infrastructure, where an Agent is responsible for the role to service an account and perform settlement of that leg.

This role is important as it determines the subsequence message behaviour.



pac Settlement Method – INDA versus INGA

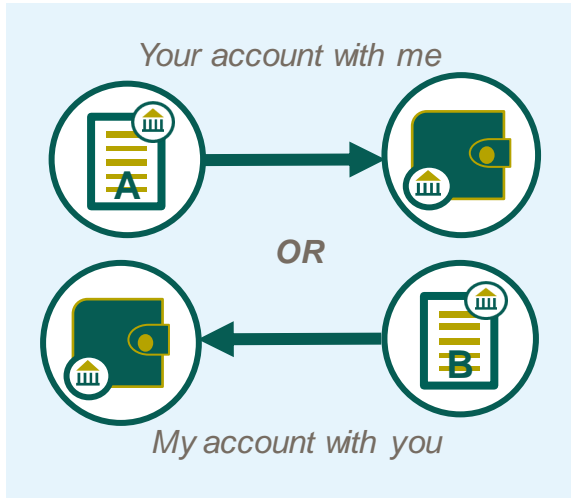

If we simplify a point-to-point message leg and look at when it is settled (booked using traditional language) we can ask ourselves: is the Instructing Agent's account held (serviced) on the books of the Instructed Agent or is the Instructing Agent holding (servicing) the account of the Instructed Agent.

Depending on the answer to this question, this determines the Settlement Method in a serial payment process.

Where the **IN**structing **G** Agent services the account and is responsible for settling the payment leg, the Settlement Method code **INGA** is used.

Where the **IN**structed **D** Agent services the account and is responsible for settling the payment leg, the Settlement Method code **INDA** is used.

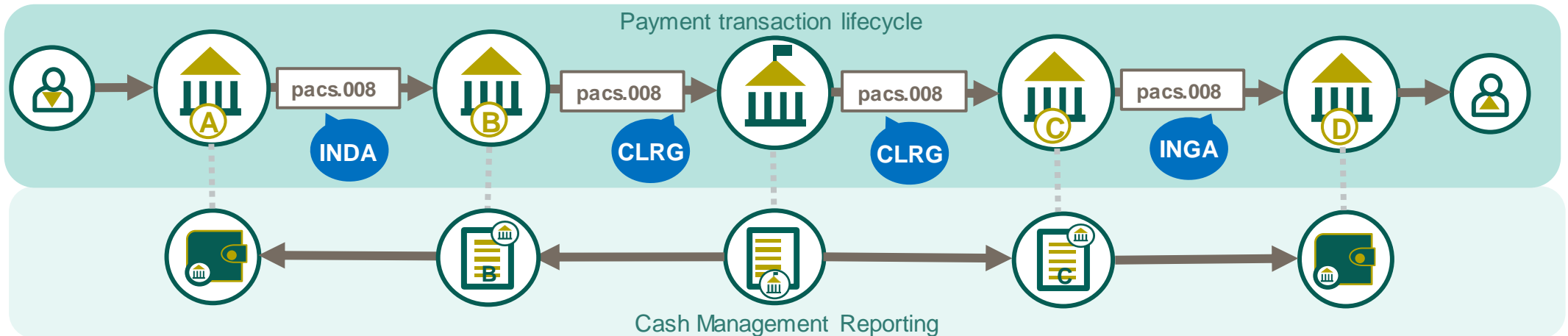

pac Settlement Method – relationship to message process flow

The relationship between the settlement of a payment leg and the message process flow is an important one. The state of settlement influences further messages in the process flow.



INGA

The pac message sent by the Instructing Agent to the Instructed Agent has already been settled.

Instructing Agent may (for example) send

- a pacs.002 to the Previous Agent with status ACSC Accepted Settlement Complete.
- a camt.053 Customer Statement to the Instructed Agent (as Account Owner)

Instructed Agent can not Reject the pac message received as it has already settled. The inability to process the pac message further by the Instructed Agent must result in a pacs.004 Payment Return (which in turn triggers a Reverse Indicator on the Account Owners statement).

Creditor Agent having performed the settlement on the Creditor's account, camt reporting message may be used to report or notify on this credit entry.

INDA

The pac message sent by the Instructing Agent to the Instructed Agent has not been settled.

Instructing Agent may (for example) send

- a pacs.002 to the Previous Agent with status ACSP Accepted Settlement in Progress

Instructed Agent may

- Reject the pac message received, using a pacs.002, as it has not been settled.
- a camt.053 Customer Statement to the Instructing Agent (as Account Owner) Although an rejected entry will not appear in the camt.053

Creditor Agent of a pacs.009 (particularly in the cover scenario) may forward the pacs.009 to the Creditor, as the Creditor will perform the settlement (they are the Account Servicing Institution)

CLRG

The pac message sent by the Instructing Agent to the Instructed Agent has not been settled. Settlement is performed by the Market Infrastructure.

Instructing Agent may (for example) send

- a pacs.002 to the Previous Agent with status ACSP Accepted Settlement in Progress

Instructed Agent may

- can not Reject the pac message received as it has already settled. The inability to process the pac message further by the Instructed Agent must result in a pacs.004 Payment Return.

Market Infrastructure may

- Reject the pac message received, using a pacs.002, as it has not been settled.
- a camt.053 Customer Statement to the Instructing Agent and Instructed Agent (as Account Owners)



High Level INGA message example

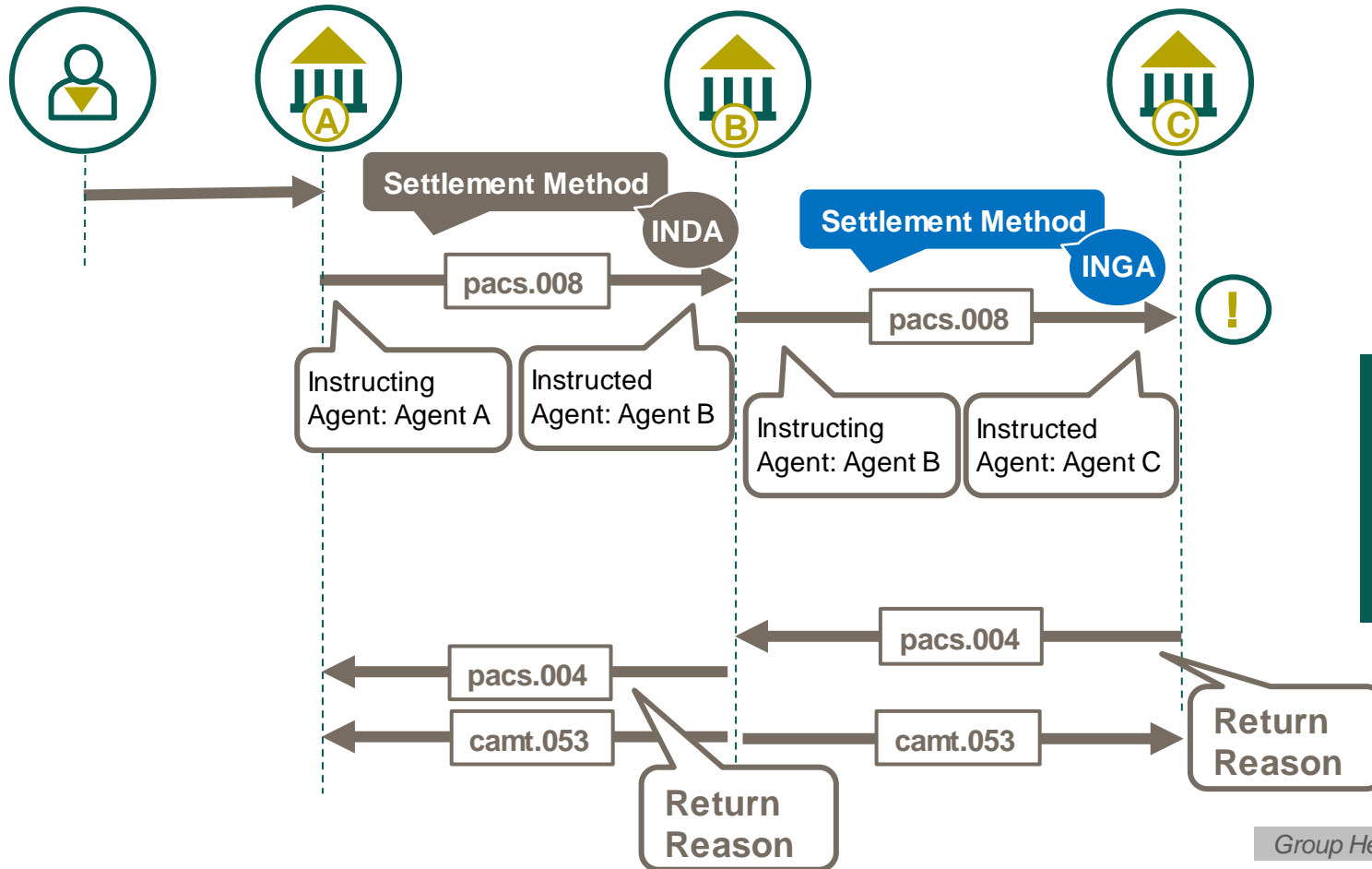

Agent C is unable to process the payment. As the payment was already settled by the Instructing Agent (Settlement Method INGA) Agent C must use a pacs.004 to instruct the return of the payment

Group Header > Settlement Information > Settlement Method



Note: return of a payment would involve a booked entry. In this example Agent B would capture the original booked entry and a separate reversed entry in the statement for Agent A and Agent C. Detail on statement entry can be found in the camt.053 section.



High Level INDA message example

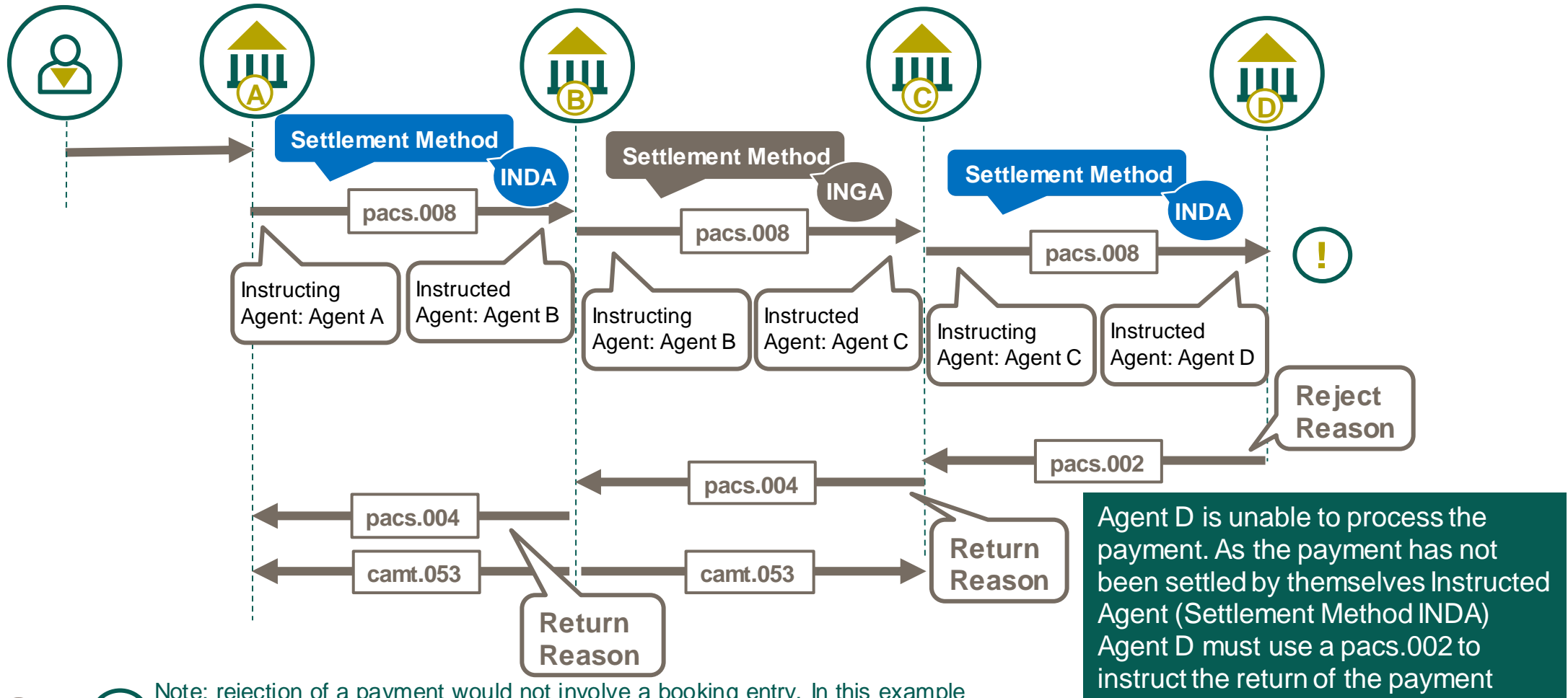

Note: rejection of a payment would not involve a booking entry. In this example Agent D would still produce a customer statement for Agent C, this rejected payment transaction would however not appear as an entry in this statement



pacs.008 FI to FI Customer Credit Transfer – Settlement Account

The pacs.008 message **Settlement Account** is a nested element as part of **Settlement Information**, this element identifies information related to an account used to settle the payment instruction.

Min 0 – Max 1

The **Settlement Account** identifies the account details maintained at the account servicing institution (Agent responsible for the settlement of the instruction as indicated in the **Settlement Method**)



Min 1 – Max 1 Identification identifies the account maintained at the Debtor Agent (Account Servicing Institution)

Min 0 – Max 1 Type uses the external Cash Account Type code list to identify the type of account

Min 0 – Max 1 Currency identifies the currency if the account

Min 0 – Max 1 Name identifies the name of the account as assigned by the Account Servicing Institution

Min 0 – Max 1 Proxy captures an alternative identification of the account number such as an email address. This element has further nested **Type** which is a choice of external code list or proprietary code and **Identification** which are both mandatory where the Proxy element is used.

pac.008 FI to FI Customer Credit Transfer – Reimbursement Agents

The pac.008 message captures a number of Reimbursement Agents as a sub element to **Settlement Information** these elements detail the Agent in the cover method who will process the pac.009 cover.

These elements are similar in nature to the Field 53, 54 and 55 in legacy MT messages and are referred to as The **Instructing Reimbursement Agent**, **Instructed Reimbursement Agent** and **Third Reimbursement Agent**. Each of these reimbursement agents also has a dedicated account element to optionally capture their related account details.



Min 0 – Max 1

The **Instructing Reimbursement Agent** captures the Agent who will execute a covering payment (i.e. pac.009 COV or domestic equivalent) often referred to as the currency correspondent. This optional element is comparable with the Field 53a in the legacy FIN message.

Min 0 – Max 1

The **Instructing Reimbursement Agent Account** captured the account related to this Reimbursement Agent. This element can be compared to the Party Identifier of the legacy Field 53.

paces.008 FI to FI Customer Credit Transfer – Reimbursement Agents (continued)



Min 0 – Max 1

The **Instructed Reimbursement Agent** captures the Agent who will receive the covering payment (i.e., pacs.009 cov or domestic equivalent) and credit the account of the pacs.008 FI to FI Customer Credit Transfer *Instructed Agent*. This optional element is comparable with the Field 54a in the legacy FIN message.

Min 0 – Max 1

The **Instructed Reimbursement Agent Account** captured the account related to this Reimbursement Agent. This element can be compared to the Party Identifier of the legacy Field 54.

Min 0 – Max 1



The **Third Reimbursement Agent** captures an additional Agent who will receive the covering payment, where this is not the Agent detailed in the *Instructed Reimbursement Agent*. This optional element is comparable with the Field 55a in the legacy FIN message.

Min 0 – Max 1

The **Third Reimbursement Agent Account** captured the account related to this Reimbursement Agent. This element can be compared to the Party Identifier of the legacy Field 55.

Credit Transfer Transaction Information



pacs.008 FI to FI Customer Credit Transfer - Payment Identification

Min 1 – Max 1

The pacs message **Payment Identification** provides a set of elements to identify the payment, of which several are mandatory elements

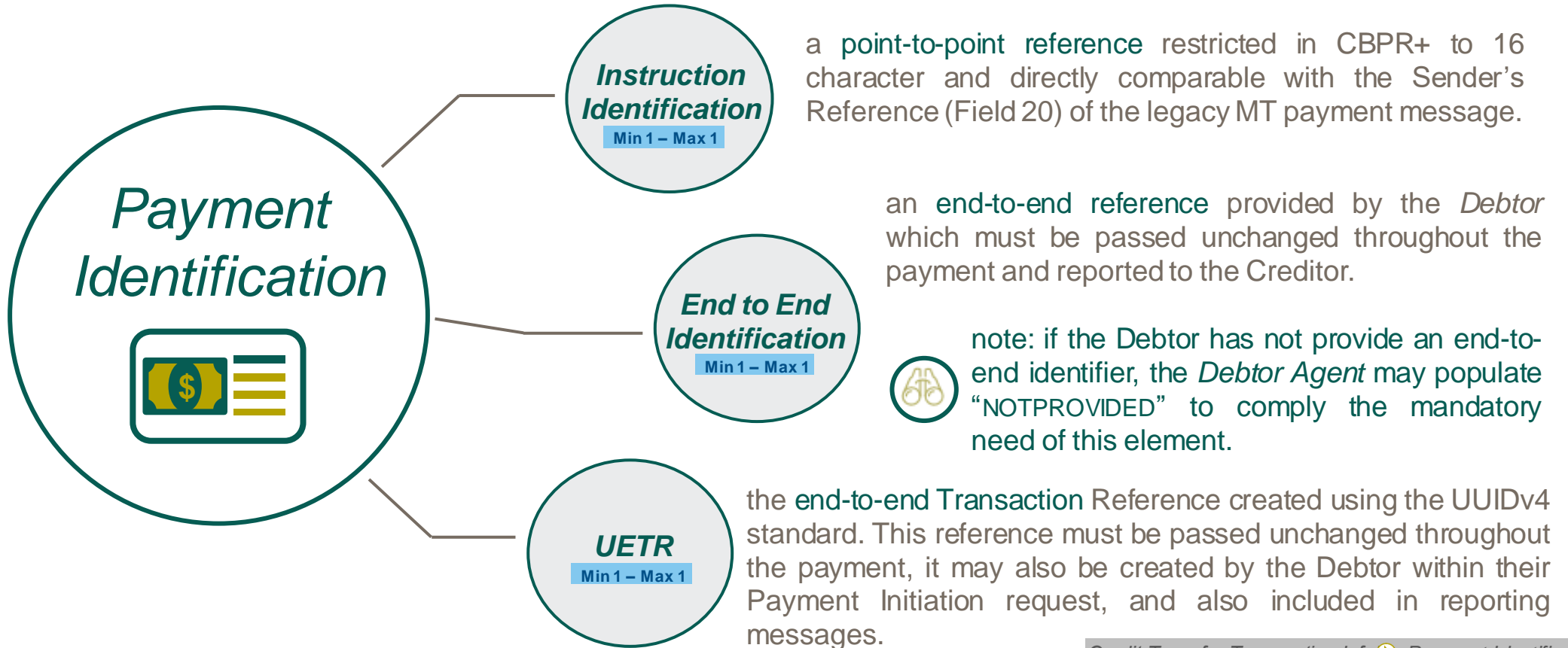

pac.008 FI to FI Customer Credit Transfer - Payment Identification (continued)

Min 1 – Max 1

The pac.008 message **Payment Identification** also provides a set of optional elements to identify the payment.

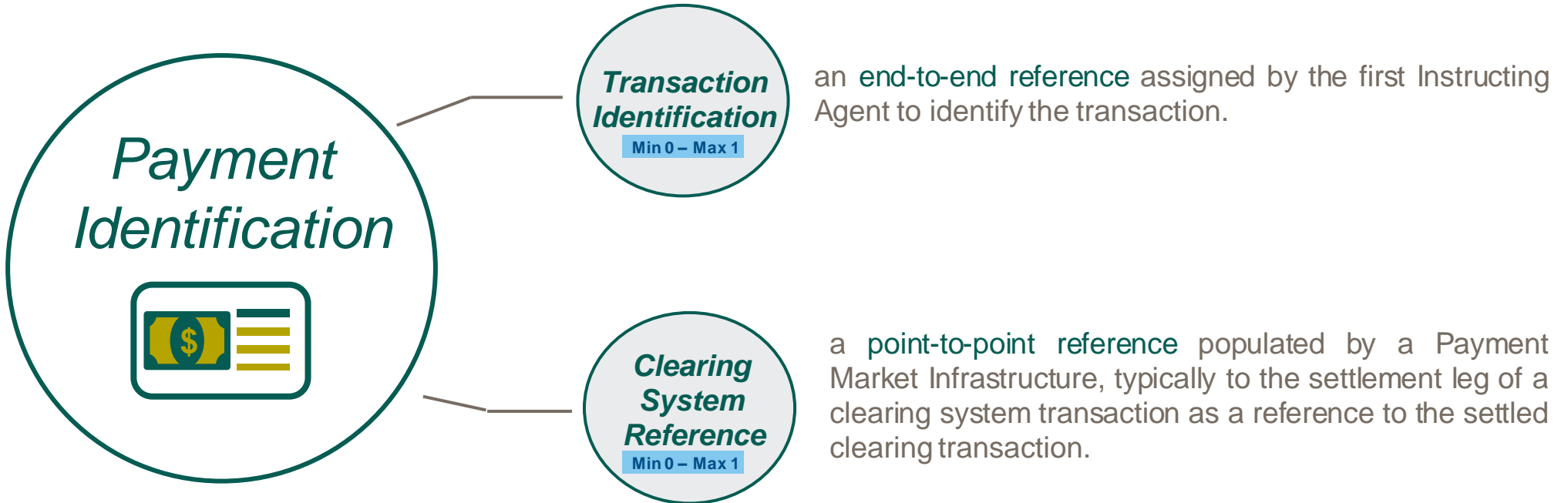

pacs.008 FI to FI Customer Credit Transfer - Payment Type Information

Min 0 – Max 1

The pacs message **Payment Type Information** provides a set of optional elements where the payment type can be described.

a choice of imbedded codes representing the urgency considered by the Instructing Agent, this point-to-point information may be used by the Instructed Agent to differentiate the processing priority.

Instruction Priority

Min 0 – Max 1

a choice of imbedded codes representing the clearing channel to be used to process the payment.
e.g., RTGS

Clearing Channel

Min 0 – Max 1

Service Level

Min 0 – Max 3

A nested element which may either use an external ISO Service Level code or a proprietary code. It is used to identify a particular agreed* service level which should be applied to the payment.

For example, code G001 can be used to identify a gpi Tracked Customer Credit Transfer similarly to Field 111 value 001 in the MT 103

Payment Type Information



Local Instrument

Min 0 – Max 1

A nested element which may either use an external ISO Local Instrument code or a proprietary code. It is used to identify the type of payment local instrument such as a Standing Order.



Note: the ISO instrument codes are registered by specific community group (captured in the code list)

Category Purpose

Min 0 – Max 1

A nested element which may either use an external ISO Category Purpose code or a proprietary code. It is used to identify the category of payment. For example, SECU Transaction is the payment of securities.

*note - where a service level is not bilaterally agreed, it may be ignored.

pacs.008 FI to FI Customer Credit Transfer – Interbank Settlement Amount and Date

The pacs.008 message has two key elements to capture the amount of the Credit Transfer, **Interbank Settlement Amount** and **Interbank Settlement Date**

Min 1 – Max 1

Min 1 – Max 1



Interbank Settlement Amount

A mandated currency amount moved between the *Instructing Agent* and the *Instructed Agent*. This therefore is the point-to-point currency amount exchanged, comparable with the MT Field 32A

Interbank Settlement Date

A mandated date on which the *Interbank Settlement* should be executed between the *Instructing Agent* and the *Instructed Agent*. This therefore is the value date comparable with the MT Field 32A



Note: the relationship between Interbank Settlement Amount and Instructed Amount is an important one. Instructed Amount relates to the amount Instructed to be executed from the Debtor's account and only need to be captured in the Instructed Amount where the Interbank Settlement Amount is not the same currency amount.



Credit Transfer Transaction Information ✓

➤ Interbank Settlement Amount

➤ Interbank Settlement Date

204

pac.008 FI to FI Customer Credit Transfer – Settlement Priority, Time Indication & Request

The pac.008 message has three optional elements to capture the optional information related to the settlement of the instructions.

Min 0 – Max 1



The **Settlement Priority** provides an optional choice of embedded codes to indicate the instruction's settlement priority from the perspective of the Instructing Agent. This point-to-point information may be used by the Instructed Agent to identify the priority associated with the **Settlement Method** and should not be confused with the **Instruction Priority**.



Note: where **Settlement Method** of the pac.008 is 'COVE' (settled via a covering pac.009 COV) Settlement Priority is relevant to the covering payment not the pac.008

Min 0 – Max 1



The **Settlement Time Indication** optionally captures the time settlement occurred at a transaction administrator such as a Market Infrastructure.

This DateTime can be captured in two nested elements, **Debit Date Time** and **Credit Date Time**.

Min 0 – Max 1



The **Settlement Time Request** optionally captures the time settlement is requested for the payment instruction by the Instructing Agent. This Time can be capture in four nested elements:

- **CLS Time** the time the amount must be credit to CLS Bank
- **Till Time** the time until which the payment may be settled
- **From Time** the time from which the payment may be settled
- **Reject Time** the time from which the payment must be settled (to avoid reject)

Credit Transfer Transaction Information

pacs.008 FI to FI Customer Credit Transfer – Instructed Amount and Exchange Rate



Min 0 – Max 1

The **Instructed Amount** captures currency and amount instructed by the Debtor. This conditional element is required when the **Interbank Settlement Amount** is not the same currency and/or amount as originally instructed by the *Debtor*. For example, a charge is taken, or the transactions is converted to another currency. This element is comparable with the legacy Field 33B.

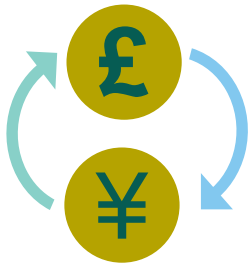

Min 0 – Max 1

The **Exchange Rate** capture the factor (rate) used to convert an amount from one currency into another. This reflects the currency pair price at which one currency was bought with another currency.



As a best practice to provide consistency and transparency the **Exchange Rate** used to convert the **Instructed Amount** (*base currency*) to the **Interbank Settlement Amount** (*quote currency*) should use the Instructed currency as the whole unit to perform the exchange.

For example if **Instructed Amount** currency is CAD and the **Interbank Settlement** currency is USD the rate should reflected as 0.83 (CAD 1 equals USD 0.83)



Note: a number of Cross Element Rules exist which relate to the **Instructed Amount** element. For example if the **Instructed Amount** is present and the currency is different from the currency in **Interbank Settlement Amount**, then **Exchange Rate** must be present.

Credit Transfer Transaction Information

➤ Instructed Amount

➤ Exchange Rate



pacs.008 FI to FI Customer Credit Transfer – Charge Bearer

Min 1 – Max 1

The mandated **Charge Bearer** element uses an embedded code that is used to specify which party/parties would bear any charges associated with processing the payment transaction. This element is comparable with MT Field 71A ‘Details of Charges’

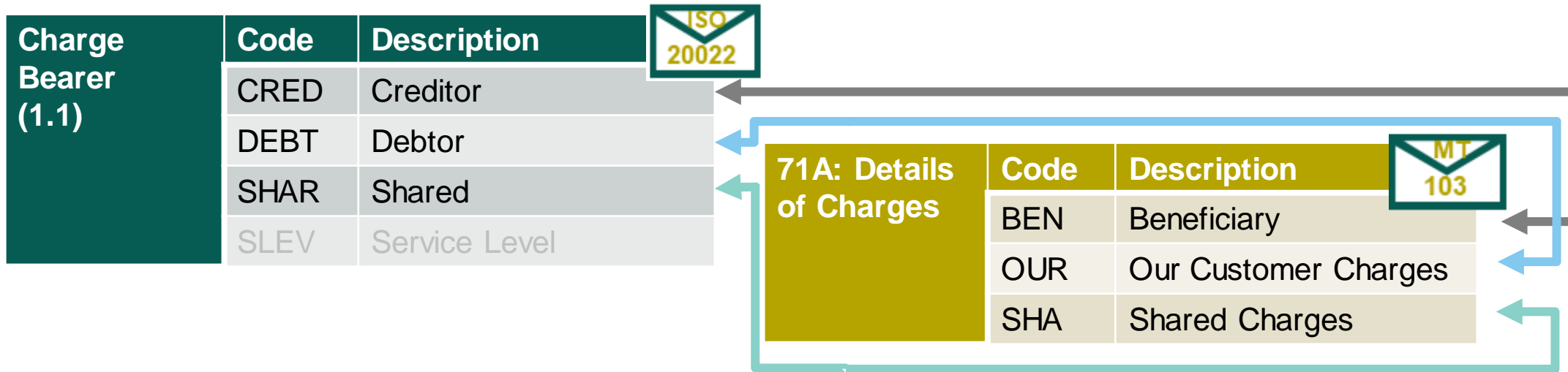

Note: *Charge Bearer* code SLEV applies following rules agreed as part of a bilateral agreed Service Level or as part of a scheme (commonly used in Instant Payment schemes) This code has no equivalent in legacy MT messages. SLEV is removed from CBPR+ usage guideline specifications for the beginning of the coexistence period.

pac.008 FI to FI Customer Credit Transfer – Charge Information

Min 0 – Max *

The **Charges Information** element provides information on the charges to be paid by the **Charge Bearer**. This element is comparable with MT Fields: 71F ‘Senders Charges’ and 71G ‘Receiver’s Charges’

Min 1 – Max 1

Charge Information (0.*)	Amount	
	Currency	
	Agent	BICFI
		Name
Structured Postal Address		

In addition to the legacy MT message the pac.008 *Charge Information* mandate the *Agent*, this represent the Agent for who the Charges are either; due (pre-paid charges) or has taken a charge (deduct from the transaction)



CBPR+ best practice recommends the use of the structured Agent BIC.

As the **Charges Information** element is repetitive it can capture charges related to previous legs of the payment transaction.



Note: As the *Charge Information* element has the capability to capture both charges deducted and charges included i.e. pre-paid charges, the use of the *Interbank Settlement Amount* and *Instructed Amount* elements play an important role.

Also note: If Charge Bearer DEBT is provided only one optional occurrence of pre-paid charges is allowed. Deducted Charges are not appropriate with Charge Bearer DEBT.

Credit Transfer Transaction Info Charge Information

pacs.008 FI to FI Customer Credit Transfer – High Level example involving a deduction of charges

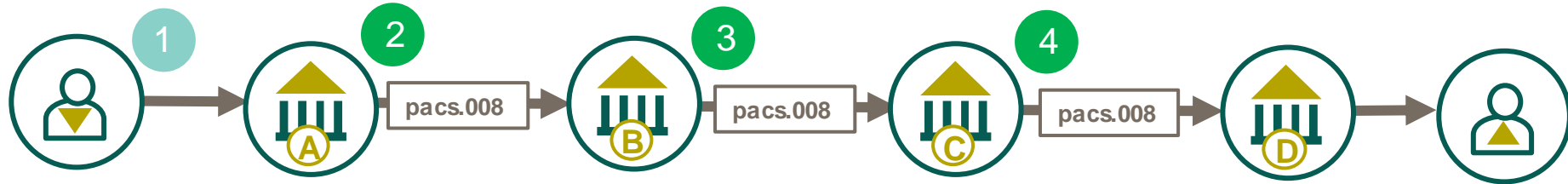

1 Debtor requests a payment for USD 100 specifying the charges should be shared

2 Debtor Agent executes the USD 100 payment charging the Debtor as commercially agreed.

3 Agent B processes the payment deducting their fee of USD 10

4 Agent C processes the payment deducting their fee of USD 5

Interbank Settlement Amount	USD 100
-----------------------------	---------

Charge Bearer	Code	SHAR
---------------	------	------

Interbank Settlement Amount	USD 90
Instructed Amount	USD 100

Charge Bearer	Code	SHAR
---------------	------	------

Charge Information	Amount	10
	Currency	USD
	Agent	BIC

Interbank Settlement Amount	USD 85
Instructed Amount	USD 100

Charge Bearer	Code	SHAR
---------------	------	------

Charge Information	Amount	10
	Currency	USD
	Agent	BIC

Charge Information	Amount	5
	Currency	USD
	Agent	BIC



pacs.008 FI to FI Customer Credit Transfer – High Level example involving the pre-payment of charges

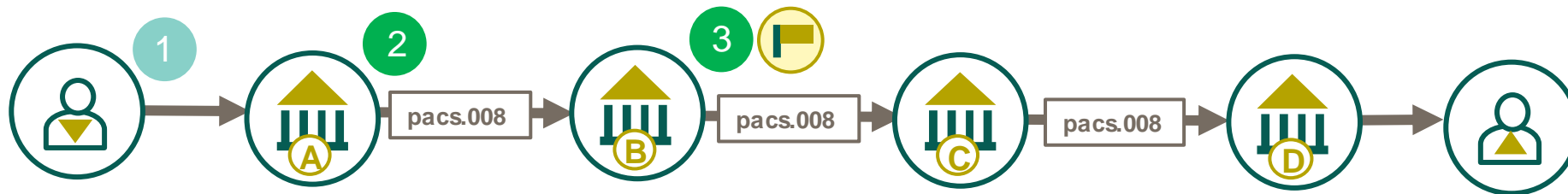

1 Debtor requests a payment for USD 100 specifying any charges will be borne by them, in accordance with their banking agreement.

2 Debtor Agent executes the USD 100 payment including a previous negotiated pre-payment of charges (USD 30). The Debtor is debited for USD 100 plus the Charges in accordance with their account agreement.

3 Agent B identifies the pre-payment of charges by the inclusion of their BIC in the Charge Information Agent element. Removing charge (USD 30), they forward the payment to the next Agent. The next Agent may request a charge.

 Pre-payment of charges are identified by the instructed Agent by the inclusion of their BIC in the Charge Information Agent element of the payment message they receive

Interbank Settlement Amount		USD 130
Instructed Amount		USD 100
Charge Bearer	Code	DEBT
	Amount	30
Charge Information	Currency	USD
	Agent	BIC BBBBUS3N

Interbank Settlement Amount	USD 100
-----------------------------	---------

Charge Bearer	Code	DEBT
---------------	------	------

 pre-payment of charge versus bearing the cost of claimed charges, may be various combinations

pacs.008 FI to FI Customer Credit Transfer – High Level example involving the pre-payment of multiple charges

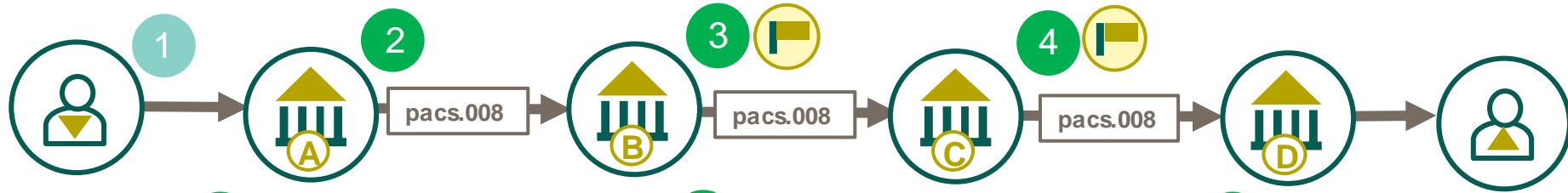

1 Debtor requests a payment for USD 100 specifying any charges will be taken by them, in accordance with their banking agreement.

2 Debtor Agent executes the USD 100 payment including a previous negotiated pre-payment of charges (USD 30). The Debtor is debited for USD 100 plus the Charges in accordance with their account agreement.

3 Agent B identifies the pre-payment of charges by the inclusion of their BIC in the Charge Information Agent element. Removing charge (USD 30), they forward the payment, including USD 20 of pre-payment of charges of the next Agent.

4 Agent C identifies the pre-payment of charges by the inclusion of their BIC in the Charge Information Agent element. Removing this pre-payment of charges they forward the payment to the Next Agent and indicate they will bear the cost of any charge claims.

 Pre-payment of charges are identified by the instructed Agent by the inclusion of their BIC in the Charge Information Agent element of the payment message they receive

Interbank Settlement Amount		USD 130	
Instructed Amount		USD 100	
Charge Bearer	Code	DEBT	
	Agent	BBBUS3N	
Charge Information	Amount	30	
	Currency	USD	
	Agent	BIC	BBBUS3N

Interbank Settlement Amount		USD 120	
Instructed Amount		USD 100	
Charge Bearer	Code	DEBT	
	Agent	CCCCUS3N	
Charge Information	Amount	20	
	Currency	USD	
	Agent	BIC	CCCCUS3N

Interbank Settlement Amount		USD 100	
Charge Bearer	Code	DEBT	
	Agent		

 pre-payment of charge versus bearing the cost of claimed charges, may be various combinations

pac.008 FI to FI Customer Credit Transfer – Charge Information

ISO 2022 pac.008 message standards document **“If ChargesInformation is present, then the currency of ChargesInformation/ChargesAmount is recommended to be the same as the currency of InterbankSettlementAmount”**

Interbank Settlement Amount received	Interbank Settlement Amount forwarded	Currency of Charge Information (where a charge occurs)
USD	USD	USD
USD	EUR	EUR



ISO 2022 does not prevent Charges from being booked in a different currency, but for transparency the Charge should be represented within the Charge Information in the Interbank Settlement Amount Currency.

pacs.008 FI to FI Customer Credit Transfer – High Level example involving a deduction of charges

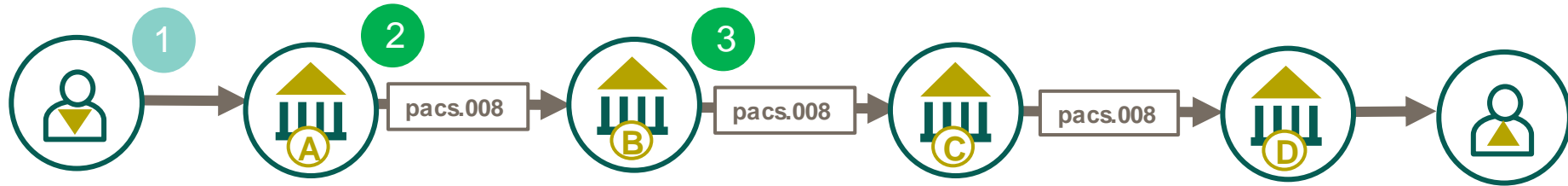

1 Debtor requests a payment for GBP 100 to be initiated from their USD account, specifying the charges should be borne by the Creditor

2 Debtor Agent executes a payment for GBP 95 (GBP 100 minus a 5 GBP charge deducted as this is borne by the Creditor).

3 Agent B processes the payment deducting their fee of GBP 10

Interbank Settlement Amount	GBP 95		
Instructed Amount	GBP 100		
Charge Bearer	Code	CRED	
Charge Information	Amount	5	
	Currency	GBP	
	Agent	BIC	AAAAGB22

Interbank Settlement Amount	GBP 85		
Instructed Amount	GBP 100		
Charge Bearer	Code	CRED	
Charge Information	Amount	5	
	Currency	GBP	
	Agent	BIC	AAAAGB22
Charge Information	Amount	10	
	Currency	GBP	
	Agent	BIC	BBBBGB2L



pacs.008 FI to FI Customer Credit Transfer – Previous Instructing Agents

The pacs message can capture up to 3 Previous Instructing Agents, which represent an Agent who previously only played a dynamic role in the payment between the Debtor Agent and Creditor Agent.

Min 0 – Max 1

The **Previous Instructing Agent 1** captures the first historic Agent between the Debtor Agent and the Previous Instructing Agent 2 (where present) and the Instructing Agent. This optional element is comparable with the Field 72 first /INS/ occurrence in the legacy FIN message.



Min 0 – Max 1

The **Previous Instructing 1 Account** captured the account related between this Agent and Previous Instructing Agent 2 (where present) or the Instructing Agent. This optional element has not comparable field in the legacy FIN message

Min 0 – Max 1

The **Previous Instructing 2** captures the second Previous Instructing Agent between the Previous Instructing Agent 1 and the Previous Instructing Agent 3 (where present) and the Instructing Agent. This optional element is comparable with the Field 72 second /INS/ occurrence in the legacy FIN message.



Min 0 – Max 1

The **Previous Instructing 2 Account** captured the account related between this Agent and Previous Instructing Agent 2 (where present) or the Instructing Agent. This optional element has not comparable field in the legacy FIN message.

Min 0 – Max 1

The **Previous Instructing 3** captures the third Previous Instructing Agent between the Agent and the Instructing Agent. This optional element is comparable with the Field 72 third /INS/ occurrence in the legacy FIN message.

Min 0 – Max 1

The **Previous Instructing 3 Account** captured the account related between this Agent and Previous Instructing Agent 2 (where present) or the Instructing Agent. This optional element has not comparable field in the legacy FIN message



pac.008 FI to FI Customer Credit Transfer - Instructed and Instructing Agents

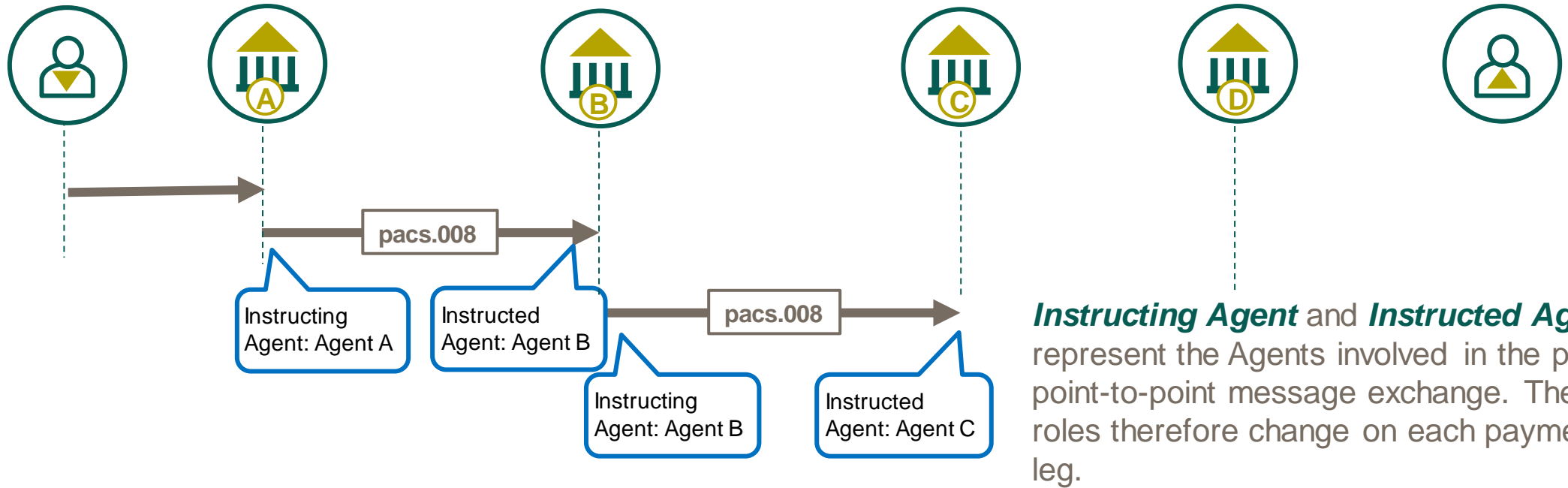

Instructing Agent and *Instructed Agent* elements are required in all pac.008 messages and are only available in the **Credit Transfer Information**

Credit Transfer Transaction Information

Instructing Agent

Instructed Agent



pac008 FI to FI Customer Credit Transfer – Previous Instructing Agents versus Intermediary Agents

The ISO 20022 pac008 messages have a number of optional Agent elements whose roles change throughout the life cycle of the payment. **Intermediary Agent** is an example of this, where these agents are classified in numeric order (i.e. *Intermediary Agent 1*) **Previous Instructing Agent** however is a static role which allows additional Previous Instructing Agent to be appended to the history of the payment.

The below diagram visualizes the change of Agent role at different stages of the payment transaction life cycle.

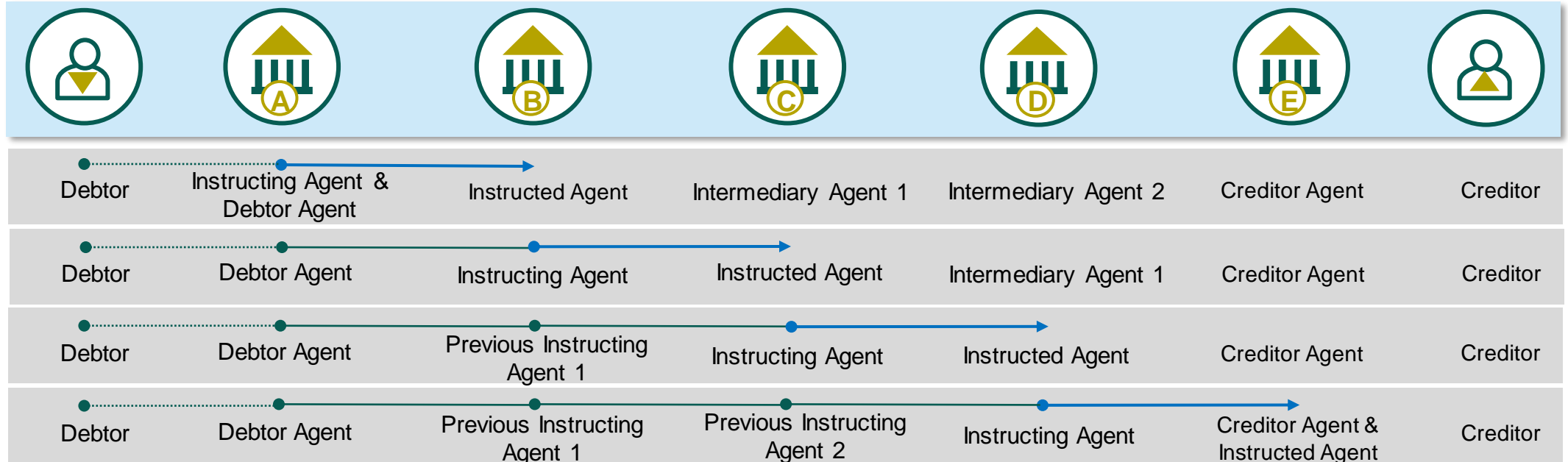

Note: the static roles of Previous Instructing Agent transition into Intermediary Agents in the potential return chain (refer to the pac004 section for Payment Returns)

pac008 FI to FI Customer Credit Transfer – Intermediary Agents

The pac008 message can capture up to 3 Intermediary Agents, which play a dynamic role in the payment between the Debtor Agent and Creditor Agent.

Min 0 – Max 1

The **Intermediary Agent 1** captures the first Intermediary Agent between the Debtor Agent and Creditor Agent for who the Instructed Agent attempt to instruct the payment on to. This optional element is comparable with the Field 56a in the legacy FIN message.



Min 0 – Max 1

The **Intermediary Agent 1 Account** captured the account related to this Intermediary Agent, with the Instructed Agent. This element can be compared to the Party Identifier of the legacy Field 56a.

Min 0 – Max 1

The **Intermediary Agent 2** captures the second Intermediary Agent between the Intermediary Agent 1 and the Creditor Agent. This optional element has not comparable field in the legacy FIN message.



Min 0 – Max 1

The **Intermediary Agent 2 Account** captured the account related to this Intermediary Agent, with the Intermediary Agent 1. This optional element has not comparable field in the legacy FIN message.

Min 0 – Max 1

The **Intermediary Agent 3** captures the third Intermediary Agent between the Intermediary Agent 2 and the Creditor Agent. This optional element has not comparable field in the legacy FIN message.



Min 0 – Max 1

The **Intermediary Agent 3 Account** captured the account related to this Intermediary Agent, with the Intermediary Agent 2. This optional element has not comparable field in the legacy FIN message.



Note: should all Previous Instructing Agents (1, 2 and 3) be utilised, Intermediary Agent should not be used. A direct and cover message would be needed instead.

pacs.008 FI to FI Customer Credit Transfer – High Level example involving a branch with authority to instruct payment from their Headquarter (HQ) settlement account.

Usually a serial payment is instructed through each Agent in a serial process. In some circumstances a branch of an Institution (Agent A) may be given Debit Authority to instruct payment from their Headquarters (Agent HQ) account with its currency correspondent (Agent B). In much the same way as if this had occurred serially, it is important that the payment instructed by Agent B correctly reflect Agent HQ as an Agent participating in the transaction, particularly if the payment is returned.

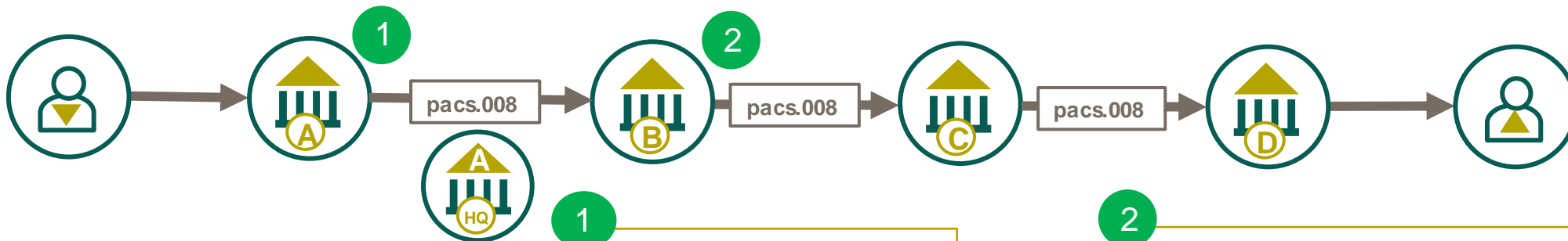

1 Debtor Agent executes the payment using their Headquarters as the settlement account

Interbank Settlement Amount	USD 100	
Settlement Account	Id	12345
Debtor Agent	AAAAGB2LABC	

2 Agent B processes the payment debiting the account of Agent A Headquarters, and including them as the Previous Instructing Agent in the payment transaction.

Interbank Settlement Amount	USD 100	
Settlement Account	12345	
Debtor Agent	AAAAGB2LABC	
Previous Instructing Agent 1	AAAAGB2L	

For transparency purpose Agent C (in this use case) has a responsibility to ensure the Agent associated with the Settlement Account is captured in the next payment leg as a Previous Instructing Agent. This also ensures, should a Payment Return occur, all the Agents can be correctly reflected in the Return Chain.



paces.008 FI to FI Customer Credit Transfer – Ultimate Debtor and Ultimate Creditor

The paces.008 message introduces ultimate parties to the FI to FI Customer Credit Transfer message. The **Ultimate Debtor** element should not be confused with an **Initiating Party** who may send a payment initiation request on behalf of the Debtor. (see dedication section on *Initiating Party*)

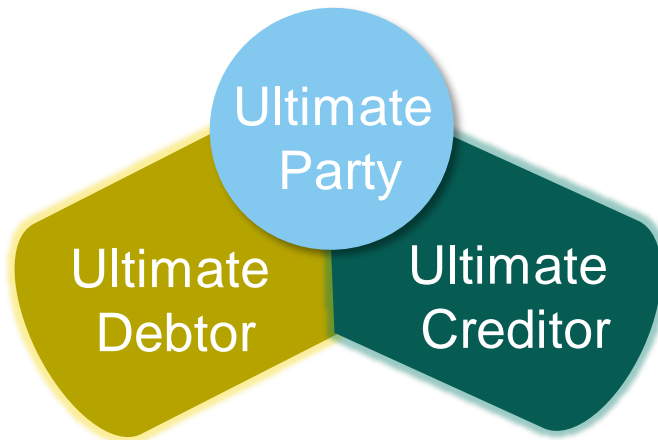

- Min 0 – Max 1 CBPR+ premise is that an **Ultimate Debtor** has no financial regulated direct account relationship with the corresponding *Debtor*.
- Min 0 – Max 1 CBPR+ premise is that an **Ultimate Creditor** has no financial regulated direct account relationship with the corresponding *Creditor*.

An account is often used a term to recognise an ongoing customer relationship. Non Agent payment provider are typically not bound by the same regulatory oversight as an Agent (Financial Institution). They would therefore be classed as a Party to a payment, where the account relationship with their customer would classify their customer as an Ultimate (Debtor or Creditor depending on the payment scenario)

Note: *Ultimate Debtor* and *Ultimate Creditor* are removed from the paces.009 Financial Institution Credit Transfer.

Credit Transfer Transaction Information 

 Ultimate Creditor

 Ultimate Debtor



pacs.008 FI to FI Customer Credit Transfer – High Level Use Case involving an Ultimate Debtor

An individual walks into a Money Transfer Bureau with relevant Private Identification (e.g. a passport) and requests a payment to be paid on their behalf to a Creditor. Having accepted payment for the transaction, the Money Transfer Bureau executes a payment initiation request to their Agent (Bank) as the Debtor, on behalf of the individual who is represented as the Ultimate Debtor.

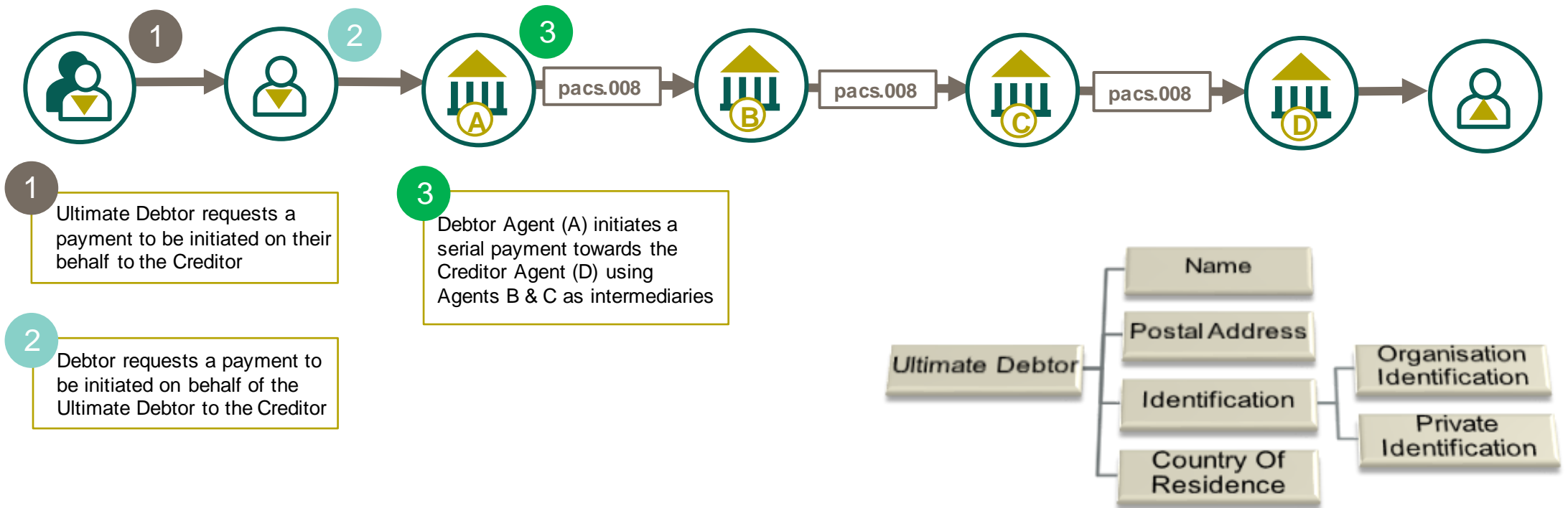

pac008 FI to FI Customer Credit Transfer – High Level Use Case involving an Ultimate Creditor

A payments is initiated to credit a retirement care facility to pay the fees of one of its residents. The retirement facility is the Creditor of the payment transaction, whereby the resident of the facility is represented as the Ultimate Creditor (beneficiary of the services the fee is paying for)

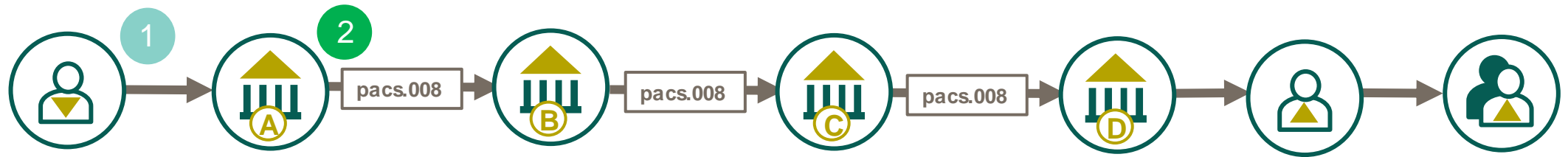

1 Debtor initiates a payment instruction to the Debtor Agent

2 Debtor Agent (A) initiates a serial payment towards the Creditor Agent (D) using Agents B & C as intermediaries

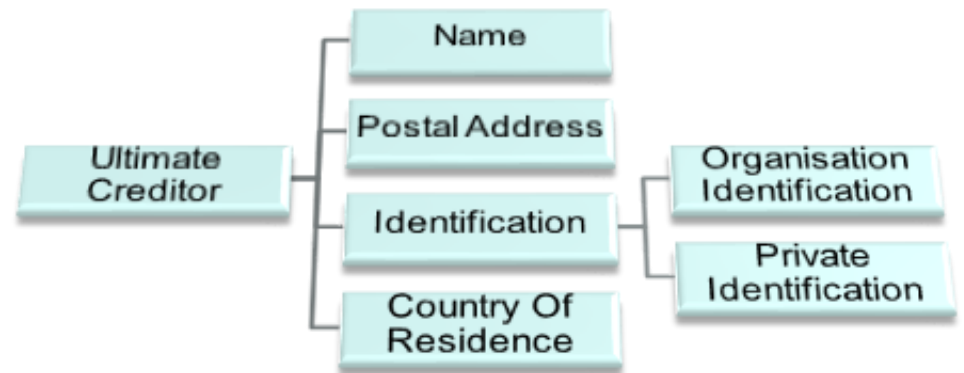

pacs.008 FI to FI Customer Credit Transfer – Initiating Party

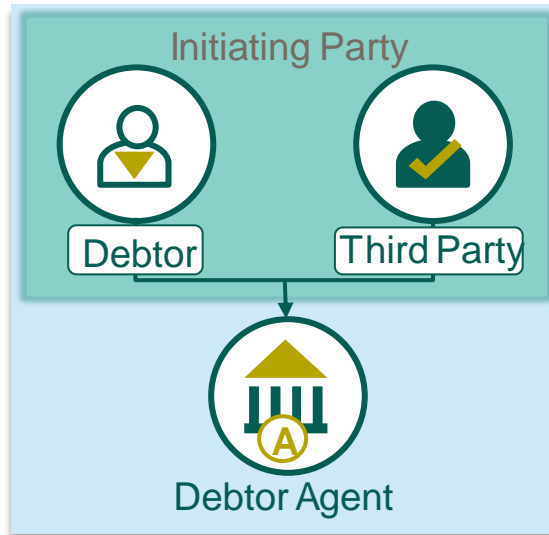

Min 0 – Max 1

The **Initiating Party** of a payment is often the **Debtor** themselves and therefore this optional element is not necessary. More often the **Initiating Party** is a third party providing payment initiation services on behalf of the **Debtor** (often referred to as a Third Party Provider) whereby the **Debtor** maintains an account with the Debtor Agent but the Third Party Provider has authority to initiate payment on behalf of the **Debtor**. This is distinctly different from an Ultimate Party (such as *Ultimate Debtor*) who instructs the **Debtor** to initiate a payment on their behalf.

Min 1 – Max 1



In the context of a Direct Debit (pacs.003) or Request to Payment (pain.013) the **Initiating Party** is often the **Creditor**, however the same context of a Third Party Provider can exist where the third party is responsible for collecting funds on behalf of the **Creditor**.

pac008 FI to FI Customer Credit Transfer – Debtor

The ISO 2022 pac008 messages describe the party debited for a transaction as the **Debtor**. The *Debtor* sub elements describe the *Debtor* in greater detail.

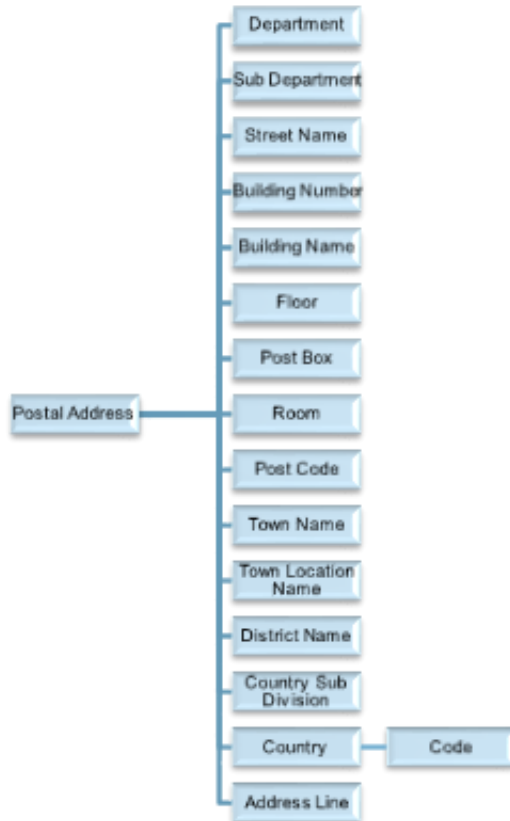

Nested element capturing either structured or unstructured *Debtor* address details

Nested element capturing the various types of identifiers for the party e.g. BIC, LEI etc.

Mandatory **Name** (where a BIC identifier is not provided) by which the party is known

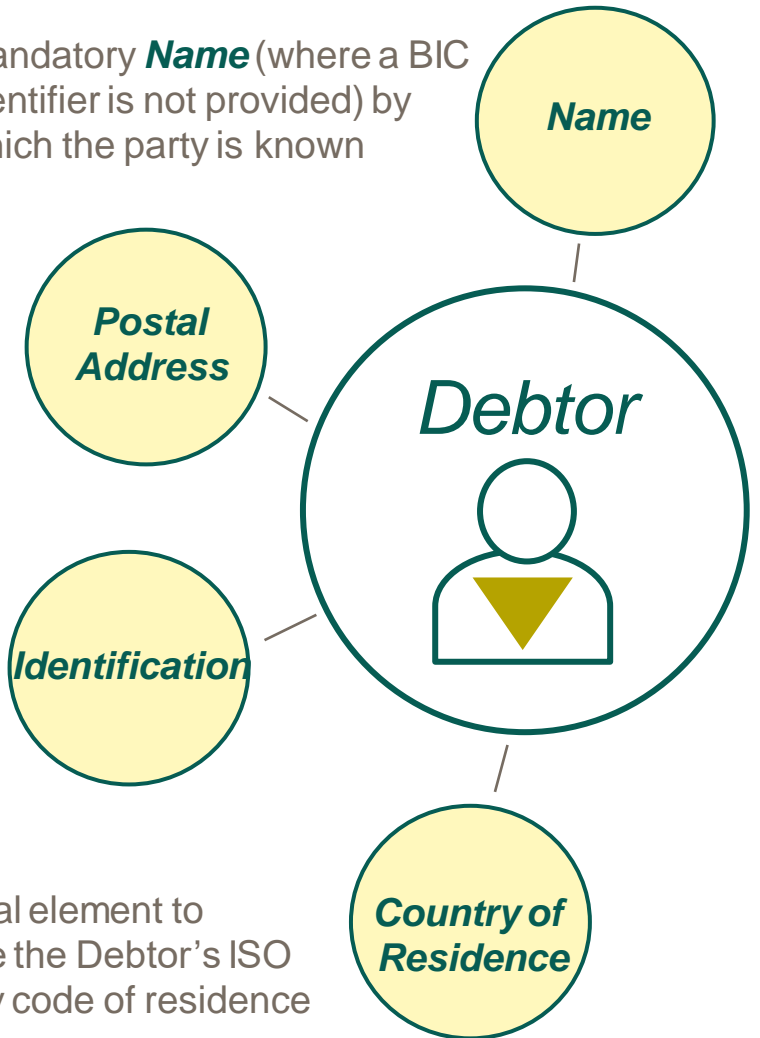

Optional element to capture the Debtor's ISO country code of residence



pac.008 FI to FI Customer Credit Transfer– Debtor Account

Min 0 – Max 1

The pac.008 **Debtor Account** is used to capture the account information for which debit entry is/has been applied to the Debtor's account, which are also reflected in their account Statement.

The **Debtor Account** uses a variety of nested elements to capture information related to the account.



Min 1 – Max 1 Identification identifies the account maintained at the Debtor Agent (Account Servicing Institution)

Min 0 – Max 1 Type uses the external Cash Account Type code list to identify the type of account

Min 0 – Max 1 Currency identifies the currency of the account

Min 0 – Max 1 Name identifies the name of the account as assigned by the Debtor Agent (Account Servicing Institution)

Min 0 – Max 1 Proxy captures an alternative identification of the account number such as an email address. This element has further nested **Type** which is a choice of external code list or proprietary code and **Identification** which are both mandatory where the Proxy element is used.

pacs.008 FI to FI Customer Credit Transfer - Structured data example

ISO 2022 Debtor data element example				Customer data record example		MT – free format option	
Debtor	Name			JOHN HECTOR JOSEPH SMITH - MASTERSONS		:50K:/BE3000121637141 JOHN HECTOR JOSEPH SMITH - MASTERSO HOOGSTRAAT 6 BRUSSELS 1000 BELGIUM PASSPORT 1111111111	
	Postal Address	Department					
		Sub Department					
		Street Name		HOOGSTRAAT			
		Building Number		6			
		Post Code		1000			
		Town Name		BRUSSELS			
		Country		BE			
Identification	Private Id	Other	Id		1111111111		
			Scheme Name	Code	CCPT		
Debtor Account	Identification	IBAN		BE3000121637141			

MT – structured option with risk of potential truncation & loss of info

:50F:/BE3000121637141
 1/JOHN HECTOR JOSEPH SMITH - MASTER
 1/SONS
 2/HOOGSTRAAT 6
 3/BE/BRUSSELS 1000



Note: The richness of ISO 2022 allows more granular data structures compared to the legacy FIN formatting options 225

pac.008 FI to FI Customer Credit Transfer – Debtor Agent and Creditor Agent

Min 1 – Max 1

Min 1 – Max 1

The **Debtor Agent** and **Creditor Agent** are static roles in the pac.008 FI to FI Customer Credit Transfer. These agents maintain a relationship with their customers; the *Debtor* and *Creditor*.



Note: Although the **Debtor Agent**, **Creditor Agent**, **Debtor** and **Creditor** all maintain static roles in the pac messages, the description of these parties change in the reporting messages (camt) where the Debtor Agent and Creditor Agent become the Statement Account Servicer and the Debtor and Creditor become the Statement Account Owner. This will be explored further in the camt Cash Management Reporting section.

Credit Transfer Transaction Information 

 Debtor Agent

 Creditor Agent

pac.008 FI to FI Customer Credit Transfer– Debtor Agent Account and Creditor Agent Account

Min 0 – Max 1

The pac.008 **Debtor Agent Account** and **Creditor Agent Account** are used to capture the account information related to these Agents. The nature of this element implies there is an Agent or Agent in between the Debtor Agent and Creditor Agent in the payment transaction.

The **Debtor Agent Account** and **Creditor Agent Account** uses a variety of nested elements to capture information related to the account.



Min 1 – Max 1

Identification identifies the account maintained at the Account Servicing Institution
Type uses the external Cash Account Type code list to identify the type of account

Min 0 – Max 1

Currency identifies the currency of the account

Min 0 – Max 1

Name identifies the name of the account as assigned by the Account Servicing Institution

Min 0 – Max 1

Proxy captures an alternative identification of the account number such as an email address. This element has further nested **Type** which is a choice of external code list or proprietary code and **Identification** which are both mandatory where the Proxy element is used.



Debtor Agent and Creditor Agent are a Financial Institution, therefore the nested elements **Name** and **Proxy** are unlikely to be used.



paces.008 FI to FI Customer Credit Transfer – Creditor

The ISO 20022 pacs messages describe the party credited for a transaction as the **Creditor**. The *Creditor* sub elements describe the *Creditor* in greater detail.

Mandatory **Name** (where a BIC identifier is not provided) by which the party is known

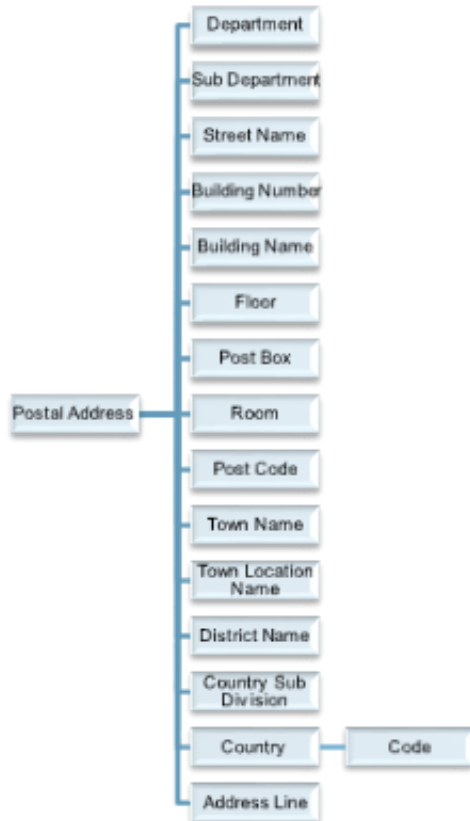

Nested element capturing either structured or unstructured **Creditor** address details

Nested element capturing the various types of identifiers for the party e.g. BIC, LEI etc.

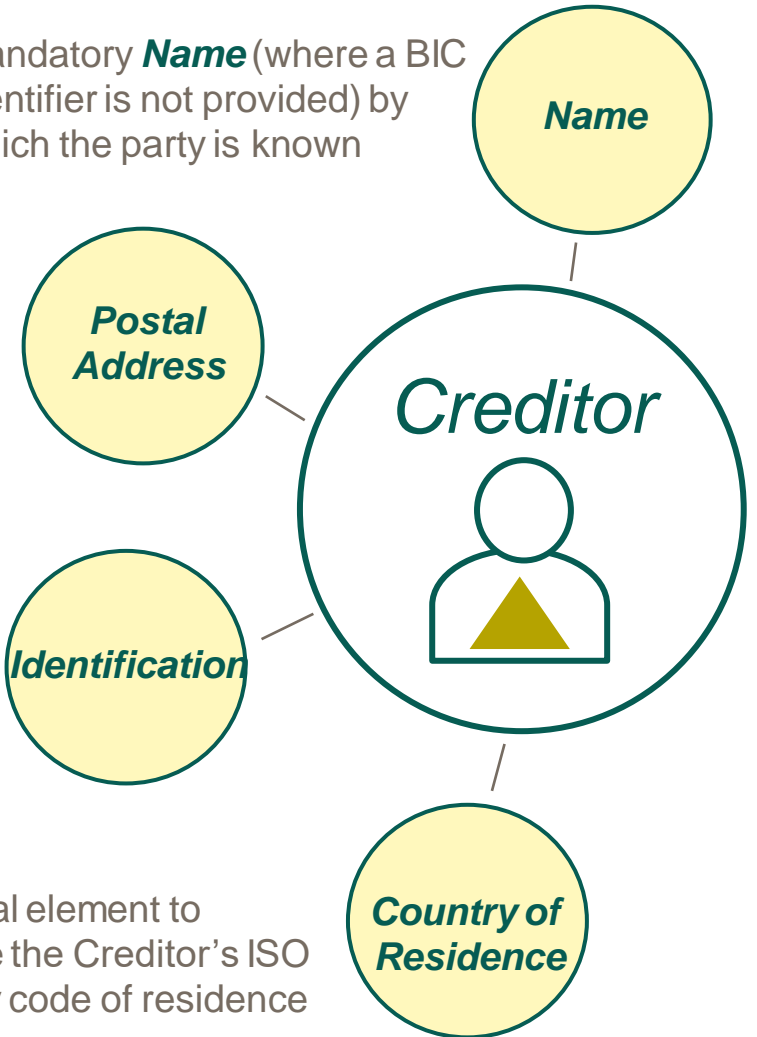

Optional element to capture the Creditor's ISO country code of residence



pac.008 FI to FI Customer Credit Transfer – Creditor Account

Min 0 – Max 1

The pac.009 **Creditor Account** is used to capture the account information for which a credit entry is intended to be applied to the Creditor's account, which are also reflected in their account Statement.

The **Creditor Account** uses a variety of nested elements to capture information related to the account.



Min 1 – Max 1 Identification identifies the account maintained at the Creditor Agent (Account Servicing Institution)

Min 0 – Max 1 Type uses the external Cash Account Type code list to identify the type of account

Min 0 – Max 1 Currency identifies the currency of the account

Min 0 – Max 1 Name identifies the name of the account as assigned by the Creditor Agent (Account Servicing Institution)

Min 0 – Max 1 Proxy captures an alternative identification of the account number such as an email address. This element has further nested **Type** which is a choice of external code list or proprietary code and **Identification** which are both mandatory where the Proxy element is used.

pac.008 FI to FI Customer Credit Transfer– Debtor Agent Account and Creditor Agent Account

Min 0 – Max 1

The pac.008 **Debtor Agent Account** and **Creditor Agent Account** are used to capture the account information related to these Agents. The nature of this element implies there is an Agent or Agent in between the Debtor Agent and Creditor Agent in the payment transaction.

The **Debtor Agent Account** and **Creditor Agent Account** uses a variety of nested elements to capture information related to the account.



Min 1 – Max 1

Identification identifies the account maintained at the Account Servicing Institution
Type uses the external Cash Account Type code list to identify the type of account

Min 0 – Max 1

Currency identifies the currency of the account

Min 0 – Max 1

Name identifies the name of the account as assigned by the Account Servicing Institution

Min 0 – Max 1

Proxy captures an alternative identification of the account number such as an email address. This element has further nested **Type** which is a choice of external code list or proprietary code and **Identification** which are both mandatory where the Proxy element is used.

Min 0 – Max 1



Debtor Agent and Creditor Agent are a Financial Institution, therefore the nested elements **Name** and **Proxy** are unlikely to be used.



pacs.008 FI to FI Customer Credit Transfer – Instruction For elements

The **Instruction for Next Agent** and **Instruction for Creditor Agent** elements within the pacs.009 Financial Institution Credit Transfer optionally provides information related to the processing of the payment for these Agents.



Min 0 – Max 2

The **Instruction for Creditor Agent** element offers a multiplicity of up to 2 occurrences of information. This element enables:

- the use of 2 embedded codes to describe the instruction
- free format *instruction information*
- or both, where the free format complements the code.

The use of this element may be **bilaterally** agreed with the *Creditor Agent*. It must be passed on throughout the life cycle of the transaction until the payment reaches the *Credit Agent*.



Min 0 – Max 6

The **Instruction for Next Agent** element offers a multiplicity of up to 6 occurrences of information. This element is restricted to free format *instruction information* in CBPR+. The element is used to provide instruction to the next Agent (which may not be the Creditor Agent)

Credit Transfer Transaction Information

➤ Instruction for Creditor Agent

➤ Instruction for Next Agent

pac.008 FI to FI Customer Credit Transfer – Purpose

Min 0 – Max 1

The **Purpose** element within the pac.008 FI to FI Customer Credit Transfer captures the reason for the payment transaction which may either use an external ISO **Purpose code** or a proprietary code.

The purpose is used to capture the nature of the payment e.g. **IVPT** Invoice Payment, **FEES** Payment of Fees etc. and should not be confused with Regulatory Reporting codes. By definition this information is typically defined by the Debtor.



The externalised Purpose code set is classified by the purpose, for example commercial, for which the numerous codes within the classification are each described by Name and Definition.

For example: **GDSV** is classified within the Commercial categorisation, with the *Name* **Purchase Sale of Goods and Services** described as a **Transaction is related to purchase and sale of goods**.



Category Purpose also captures a high level purpose, which unlike **Purpose** is less granular but can trigger special processing e.g. Category Purpose code **SALA** 'Salary Payment' may trigger a reporting process which restricts sensitive data i.e., individual salary names.

Credit Transfer Transaction Information

Purpose

paces.008 FI to FI Customer Credit Transfer – Regulatory Reporting

Min 0 – Max 10

The **Regulatory Reporting** element within the paces.008 FI to FI Customer Credit Transfer is nested to capture regulatory and statutory information needed to report to the appropriate authority/s.



Min 0 – Max 1

The **Debit Credit Reporting Indicator** utilises an embedded choice of code to indicate whether the regulatory reporting information applies to the:

- DEBT (debit)
- CRED (credit) or
- BOTH

Min 0 – Max 1

The **Authority** element captures the **Name** and **Country** code of the Authority/Entity requiring the regulatory reporting information.

Min 0 – Max *

The **Details** element provides the detail on the regulatory reporting information.

Credit Transfer Transaction Information > Regulatory Reporting ✓

⊗ Debit Credit Reporting Indicator

> Authority

> Details

233



pac.008 FI to FI Customer Credit Transfer – Related Remittance Information

Min 0 – Max 1

The **Related Remittance Information** element within the pac.008 FI to FI Customer Credit Transfer is nested to provide information related to the handling of remittance information. This information is typically provided by the Debtor in the payment initiation request.

Min 0 – Max 1

The **Remittance Identification** captures a unique reference assigned by the initiating party of the payment to identify the remittance information sent separately from the payment instruction.

Min 0 – Max 2

The **Remittance Location Details** uses a set of nested elements to provide information on either the location of or the delivery of remittance information.



- **Method** requires a code from an embedded list to detail the method used to deliver the remittance advise information e.g. EMAL (email)
- **Electronic Address** provides an electronic address for which an agent is to send the remittance information to e.g. the email address. It may also reference a URL where remittance information may be deposited or retrieved.
- **Postal Address** provides the postal address to which an agent is to send the remittance information

Remittance advices are typically considered as a traditional value added service provided by the Debtor Agent to the Debtor, in order to provide *Remittance Information* to the Creditor. By nature this element can travel end-to-end within the pain, pac.008 and camt reporting messages.



Remittance Information is a dedicated element used both within the pac.008 and camt reporting messages, whereby this information can travel end-to-end using ISO 20022. *Related Remittance Information* and *Remittance Information* are mutually exclusive (can't both be present)

Business examples are emerging where information is externalised using a URL repository solution.



Credit Transfer Transaction Info > Related Remittance Information >

Remittance Identification 034

> Remittance Location Details

pacs.008 FI to FI Customer Credit Transfer – Remittance Information

The optional **Remittance Information** element within the pacs.008 FI to FI Customer Credit Transfer is nested to provide either **Structured** or **Unstructured** information related to payment, such as invoices.

Min 0 – Max 1

Remittance Information enable the matching/reconciliation of an entry that the payment is intended to settle



Min 0 – Max 1

The **Unstructured** sub element captures free format *Remittance Information* which is restricted in CBPR+ to 140 characters to ensure backward compatibility with the legacy MT message during coexistence.

Min 0 – Max *

The **Structured** element is nested capturing rich structured *Remittance Information*, and is unlimited in its multiplicity, but must not exceed 9,000 characters of business information (does not include the xml element identification)

The use of this nested element should be **bilaterally/multilaterally** agreed, to ensure end-to-end transportation of this data.



Related Remittance Information and Remittance Information are mutually exclusive (can't both be present)

Credit Transfer Transaction Info > Remittance Information ✓

> Structured

Unstructured



pacs.008 FI to FI Customer Credit Transfer – Structured Remittance Information

The bilaterally/multilaterally agreed **Remittance Information** which is **Structured** must not exceed 9,000 characters of business content (i.e. the information). This nested element is used to capture a variety of structured remittance information.



example of *Structured* invoice information

The **Creditor Remittance Information** is provided to the **Creditor** in the Cash Management Reporting messages' Remittance Information component, for example, the camt.053 Bank to Customer Statement.

Structured		<Strd>			
Reference Document Information	<RfrdDocInf>	<table border="1"> <tr> <td>CINV</td> </tr> <tr> <td>A0000101</td> </tr> <tr> <td>2019-10-29</td> </tr> </table>	CINV	A0000101	2019-10-29
CINV					
A0000101					
2019-10-29					
Type	<Tp>				
Code Or Proprietary	<CdOrPrtry>				
Code	<Cd>				
Number	<Nb>				
Related Date	<Dt>				

element names

xml tag

business information



In this example Referred Document Information and its nested elements has multiplicity which support up to 9,000 character of information. Whereby this element can be repeated to include more coded information such as another invoice.

Credit Transfer Transaction Information

Remittance Information

Structured



Index of pacs.008 Use Cases

Use case should be considered as a principal example whereby use case may be cross referenced e.g. a use case involving a Market Infrastructure can apply the Market Infrastructure legs to other use cases.

Serial Financial Institution to Financial Institution to Customer Credit Transfer

Use Case p.8.1.1 – High Level FI to FI Customer Credit Transfer (pacs.008) settled over a Payment Market Infrastructure

Use Case p.8.1.2 – High Level FI to FI Customer Credit Transfer (pacs.008) Sweeps (Short position at the Secondary Account)

Cover Method Financial Institution to Financial Institution to Customer Credit Transfer

Use Case p.8.2.1 - High Level FI to FI Customer Credit Transfer settled using the cover method (pacs.009 COV) over a Payment Market Infrastructure

Use Case p.8.2.2 - High Level FI to FI Customer Credit Transfer involved a serial leg into a cover method (pacs.009 COV)

Use Case p.8.2.3 - High Level FI to FI Customer Credit Transfer involved a serial leg in and out of a cover method (pacs.009 COV)

Use Case p.8.2.4 - High Level FI to FI Customer Credit Transfer involved a serial leg out of a cover method (pacs.009 COV)

High Level FI to FI Customer Credit Transfer (pacs.008) settled over a Payment Market Infrastructure

Use Case p.8.1.1

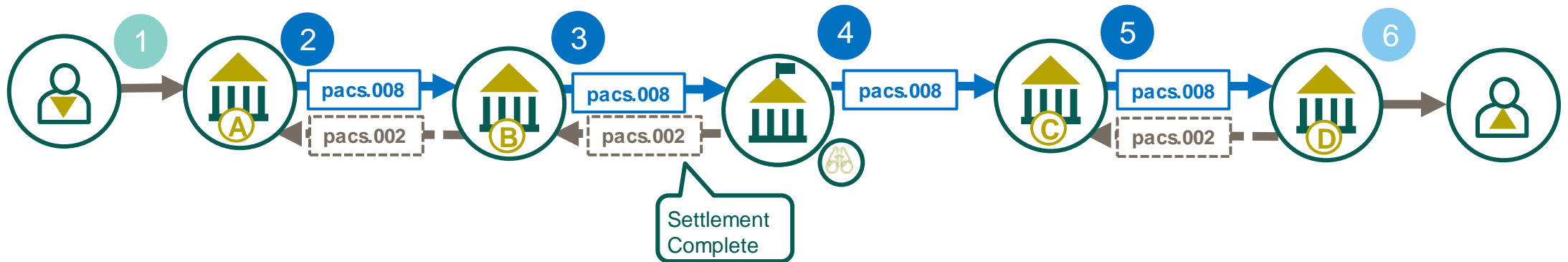

1 Debtor initiates a payment instruction to the Debtor Agent.

2 Debtor Agent (A) initiates a serial payment towards the Creditor Agent (D) using Agents B & C as intermediaries, who are direct participants of the Payment Market Infrastructure.

3 Agent B processes the payment on Agent C, via the Payment Market Infrastructure.

4 Payment Market Infrastructure, settles the payment between Agent B and Agent C as direct participants of the Market Infrastructure, and provides a settlement confirmation to Agent B.

5 Agent C processes the payment onto Agent D.

6 Agent D credits the account of the Creditor, and may optionally provide a notification e.g. credit notification in addition to an account statement (camt.053).



Market Infrastructure will either conform to HVPS+ guidelines or establish their own usage guidelines based on the ISO 20022 standard.

High Level FI to FI Customer Credit Transfer (pacs.008) initiated by an Authorised Party

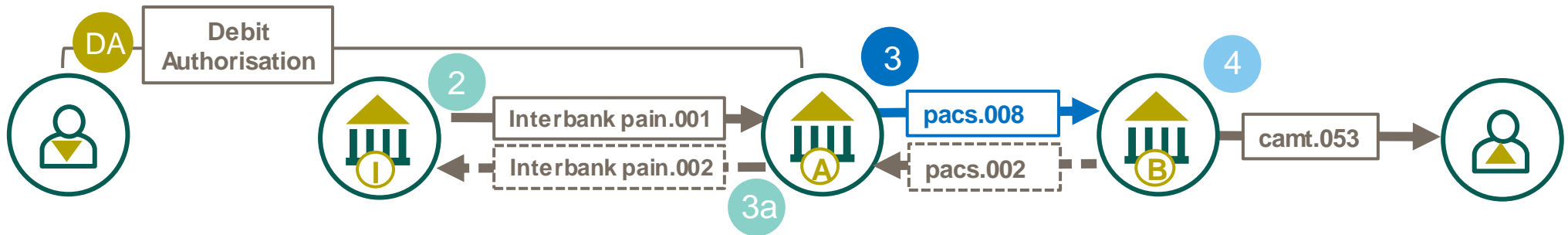

DA As a pre-requisite the Debtor provides Debit Authorisation to Agent I to Initiate Payment from their account with the Debtor Agent (A)

2 Agent (I) initiates a payment request (pain.001) to the Debtor Agent (A) to move fund from the Debtor's account, as an authorised party.

3 Debtor Agent (A) debits the account of Debtor and initiates a credit transfer

3a Debtor Agent (A) optionally provides a status update to the Initiating Party (Agent I), based upon a bilateral agreement

4 Creditor Agent (B) receives the credit transfer message, credits the Creditor, and sends a camt.053 (statement) at the end of the business day to the Creditor. An optional status report is sent to the previous Agent based upon a bilateral agreement

 See use case [pn.1.2.1](#) for an Authorised Party Payment.

High Level FI to FI Customer Credit Transfer settled using the cover method (pacs.009 COV) over a Payment Market Infrastructure

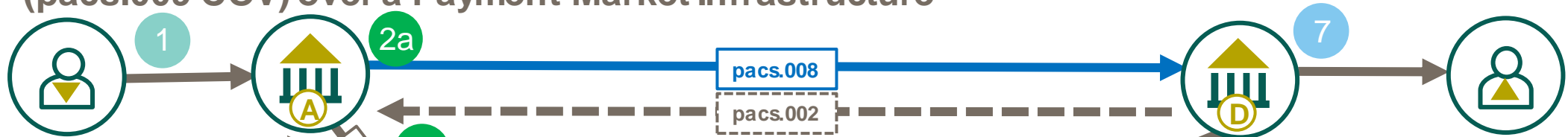

1
Debtor initiates a payment instruction to the Debtor Agent

2a
Debtor Agent (A) initiates a payment using the cover method to the Creditor Agent (D)

2b
In parallel the Debtor Agent (A) initiates a covering payment to credit the account of Agent (D) with their correspondent (Agent C)

3
Agent B processes the payment on Agent C, via the Payment Market Infrastructure.

Settlement Complete

4
Payment Market Infrastructure, settles the payment between Agent B and Agent C as direct participants of the Market Infrastructure, and provides a settlement confirmation to Agent B

5
Agent C receives the payment and credits the account of Agent D

6
Agent C produces an end of day account statement report. An optional real time notification e.g. advice of credit may have also been created at the time of the credit posting

7
Agent D reconciles the covering funds and credits the account of the Creditor, and may optionally provide a notification e.g. credit notification.



High Level FI to FI Customer Credit Transfer involved a serial leg into a cover method (pacs.009 COV)

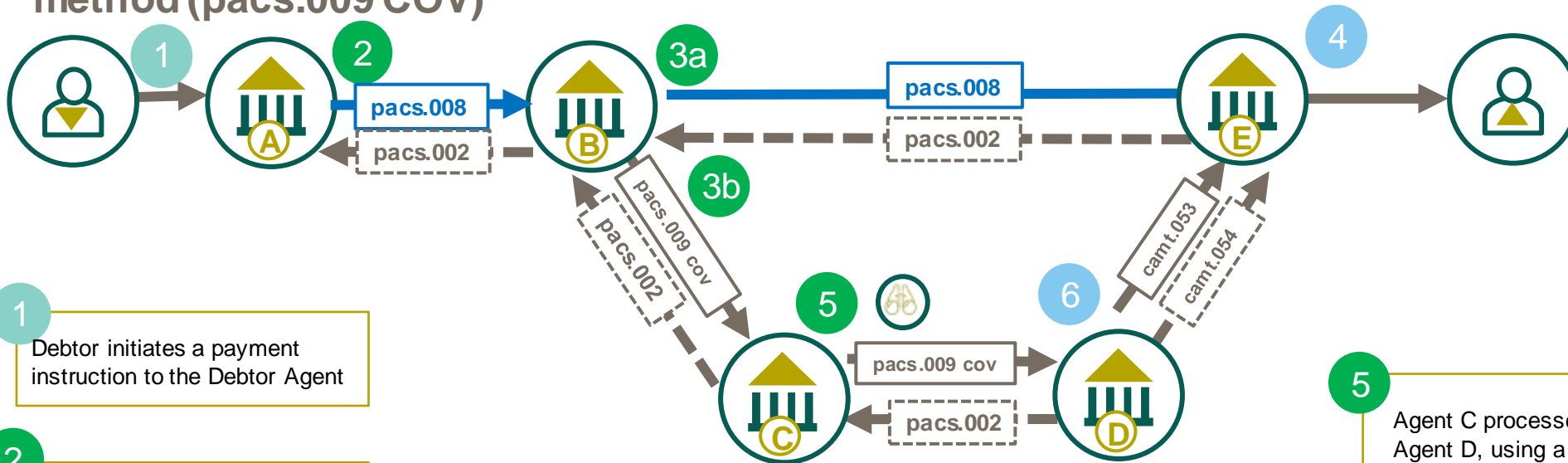

1 Debtor initiates a payment instruction to the Debtor Agent

2 Debtor Agent (A) initiates a payment using the serial method towards the Creditor Agent (E)

3a Agent B initiates a payment using the cover method towards the Creditor Agent (E) by sending a direct pacs.008 to Agent E who they have business relationship with.

3b In parallel the Agent (B) initiates a covering payment to credit the account of Agent (E) with their correspondent (Agent D)

4 Agent E receives the payment instruction and credits the account of the Creditor, and may optionally provide a notification e.g. credit notification. Alternatively, they may have chosen to await until settlement occurred in Step 6 based upon their risk appetite.

5 Agent C processes the payment on Agent D, using a correspondent banking business relationship

6 Agent D receives the payment and credits the account of Agent E. Agent D produces an end of day account statement report. An optional real time notification e.g. advice of credit may have also been created at the time of the credit posting



Note settlement of step 5 could alternative occur between Agent C and D using a Market Infrastructure..

High Level FI to FI Customer Credit Transfer involved a serial leg in and out of a cover method (pacs.009 COV)

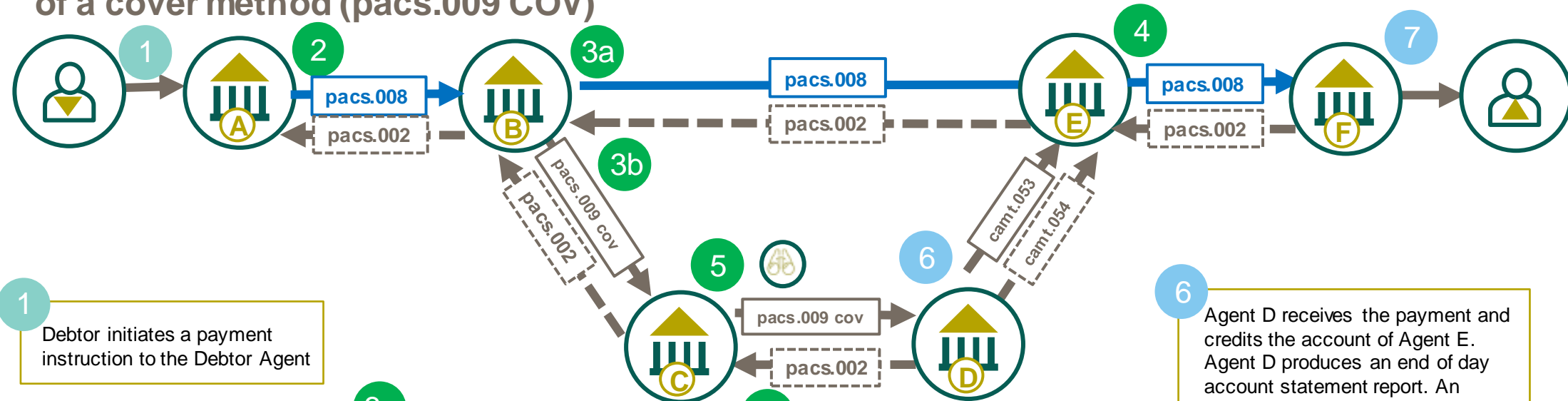

1 Debtor initiates a payment instruction to the Debtor Agent

2 Debtor Agent (A) initiates a payment using the serial method towards the Creditor Agent (F)

3a Agent B initiates a payment using the cover method towards the Creditor Agent (F) by sending a direct pacs.008 to Agent E who they have business relationship with.

3b In parallel the Agent (B) initiates a covering payment to credit the account of Agent (E) with their correspondent (Agent D)

4 Agent E receives the payment instruction and process the payment on to Agent F. Alternatively they may have chosen to await until settlement occurred in Step 6 based upon their risk appetite.

5 Agent C processes the payment on Agent D, using a correspondent banking business relationship

6 Agent D receives the payment and credits the account of Agent E. Agent D produces an end of day account statement report. An optional real time notification e.g. advice of credit may have also been created at the time of the credit posting

7 Agent F receives the payment and credits the account of the Creditor, and may optionally provide a notification e.g. credit notification.



Note settlement of step 5 could alternative occur between Agent C and D using a Market Infrastructure..

High Level FI to FI Customer Credit Transfer involved a serial leg out of a cover method (pacs.009 COV)

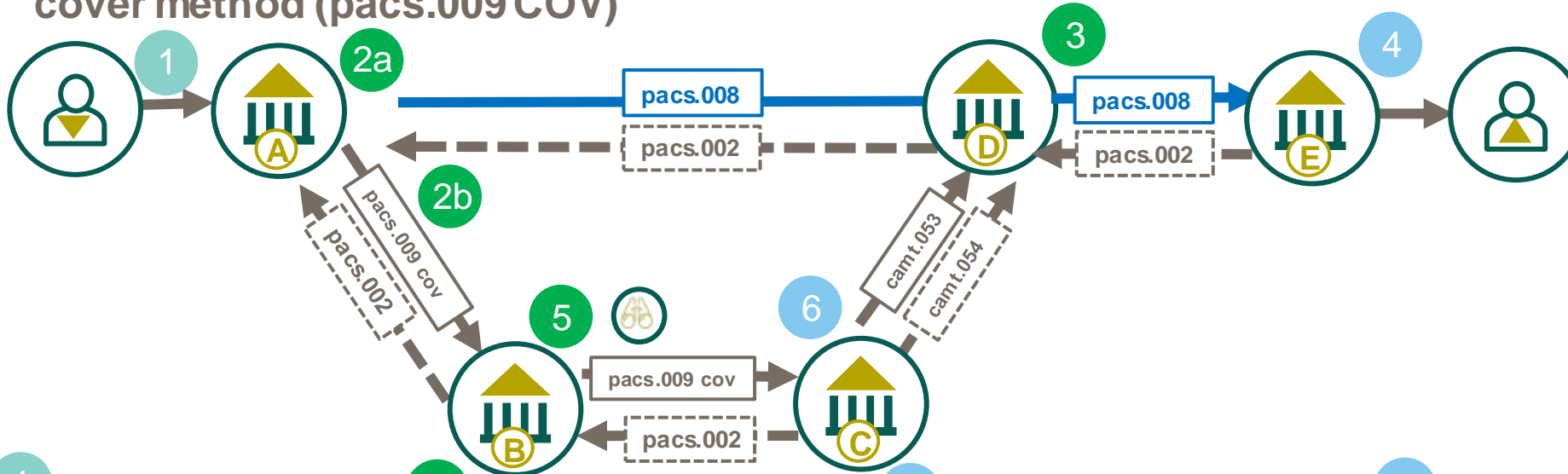

1 Debtor initiates a payment instruction to the Debtor Agent

2a Debtor Agent (A) initiates a payment using the cover method towards the Creditor Agent (E) by sending a direct pacs.008 to Agent D who they have business relationship with.

2b In parallel the Agent (A) initiates a covering payment to credit the account of Agent (D) with their correspondent (Agent C)

3 Agent D receives the payment instruction and process the payment on to Agent E. Alternatively they may have chosen to await until settlement occurred in Step 6 based upon their risk appetite.

4 Agent E receives the payment and credits the account of the Creditor, and may optionally provide a notification e.g. credit notification.

5 Agent B processes the payment on Agent C, using a correspondent banking business relationship

6 Agent C receives the payment and credits the account of Agent D. Agent C produces an end of day account statement report. An optional real time notification e.g. advice of credit may have also been created at the time of the credit posting



Note settlement of step 5 could alternative occur between Agent B and C using a Market Infrastructure..

pacs.008 STP

Financial Institution to Financial Institution Customer Credit Transfer



pac.008 STP FI to FI Customer Credit Transfer

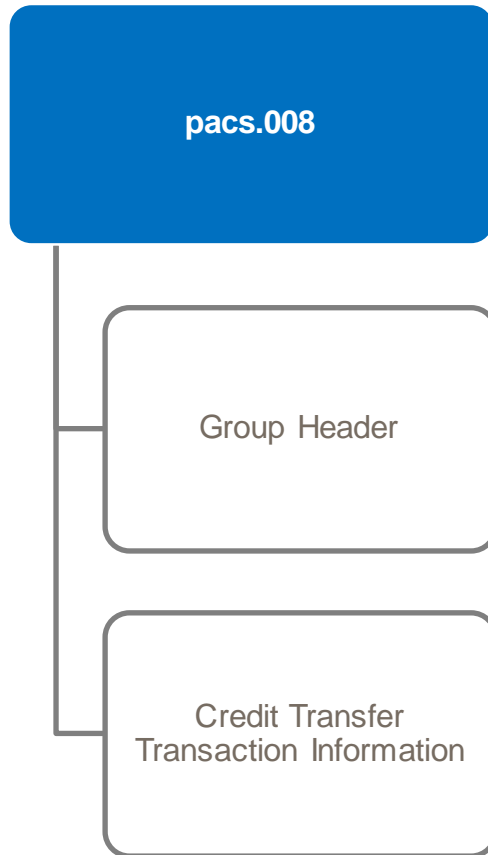

The pac.008 STP has two core sets of nested elements:

- **Group Header** which contains a set of characteristics that relates to all individual transaction
- **Credit Transfer Transaction Information** which contains elements providing information specific to the individual credit transfer transaction.



Payment messages in a many-to-many payment are considered as a single transaction. The pac.008 STP is a message who's Usage Guideline has been further restricted by remove elements considered to inhibit Straight Through Processing (STP)

High Level serial message flow

pac.008 STP

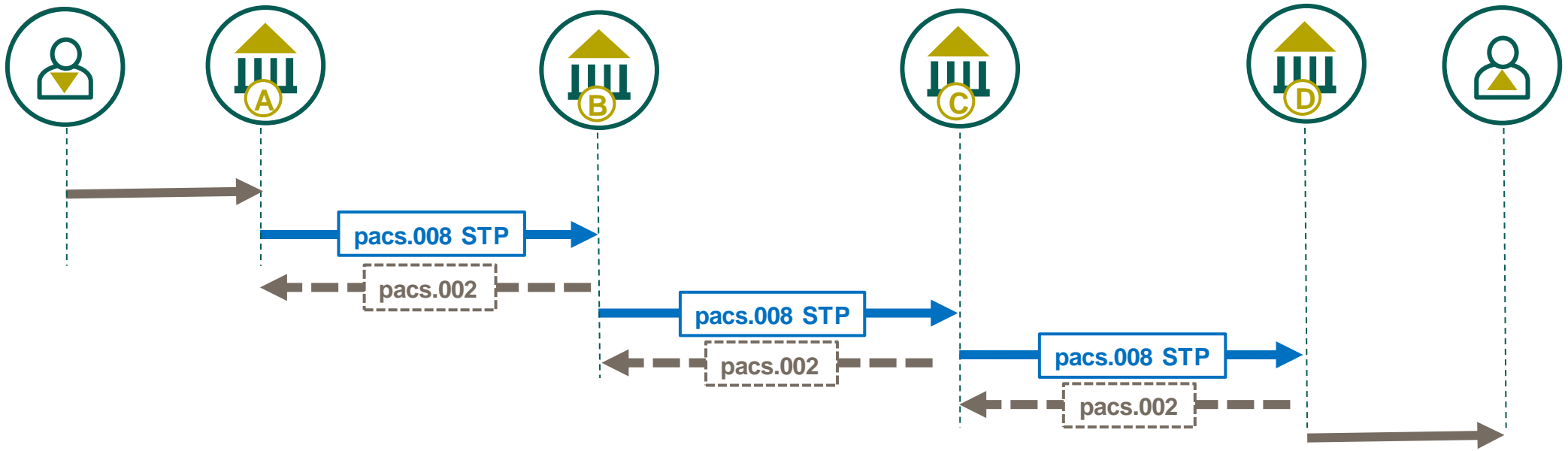

The Financial Institution To Financial Institution Customer Credit Transfer message is sent by the Debtor Agent to the Creditor Agent, directly or through other agents and/or a payment clearing and settlement system. It is used to move funds from a Debtor account to a Creditor, whereby one or both of these Parties should be a non-Financial Institution.



pac.008 STP versus pac.008 high level comparison

The pac.008 STP message has enhance STP feature over and above the pac.008 and legacy MT 103 STP. At a high level the key difference between the pac.008 and pac.008 STP are summarized.

Business Application Header
Business Service
Credit Transfer Transaction Information
Previous Instructing Agent 1
Previous Instructing Agent 2
Previous Instructing Agent 3
Intermediary Agent 1
Intermediary Agent 2
Intermediary Agent 3
Debtor Agent
Creditor Agent
Debtor
Creditor
Creditor Account
Instruction for Next Agent
Instruction for Creditor Agent
Purpose
Remittance information



swift.cbprplus.02

swift.cbprplus.stp.02

Financial Institution identifiers:

- BIC
- Clearing System Member Id
- LEI
- Name
- Postal Address

Financial Institution identifiers:

- BIC
- Clearing System Member Id
- LEI

~~Name~~ removed

~~Postal Address~~ removed

Account optional

Addition Debtor and Creditor
IBAN rules

Elements optional

Account mandatory

ISO Code or Proprietary

~~Instruction for Next Agent~~ removed
~~Instruction for Creditor Agent~~ removed

Unstructured or Structured

ISO Code or Proprietary removed

Unstructured only (structured removed)



pacs.009

Financial Institution Credit Transfer



pacs.009 (core)

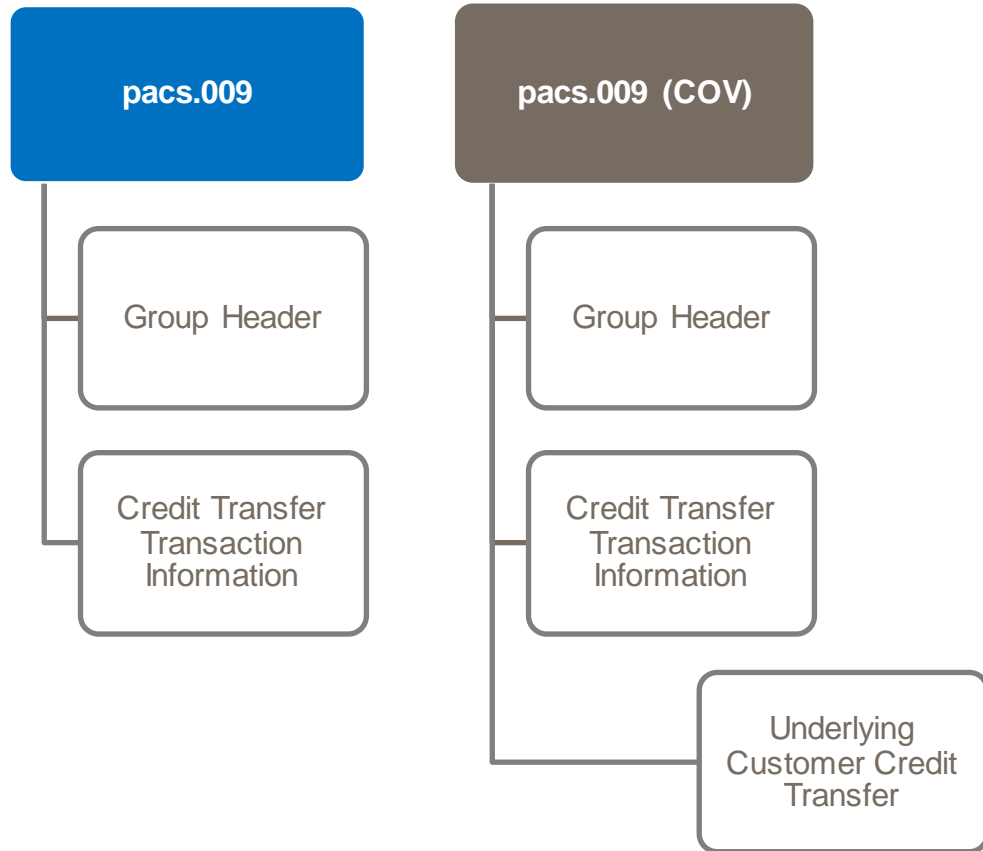

The pacs.009 has two main use cases:

- as a core Financial Institution Credit Transfer message.
- As a **COV** where it is used as cover of (to settle) a pacs.008.

The pacs.009 therefore contain information of the underlying Customer Credit Transfer (pacs.008) for use in the cover scenario, which is the key attribute to differentiate between these two use cases.

The pacs.009 may also be used as a **ADV** where it is sent as an advice and is settled using the pacs.009 as a core message.

High Level message flow

pacs.009

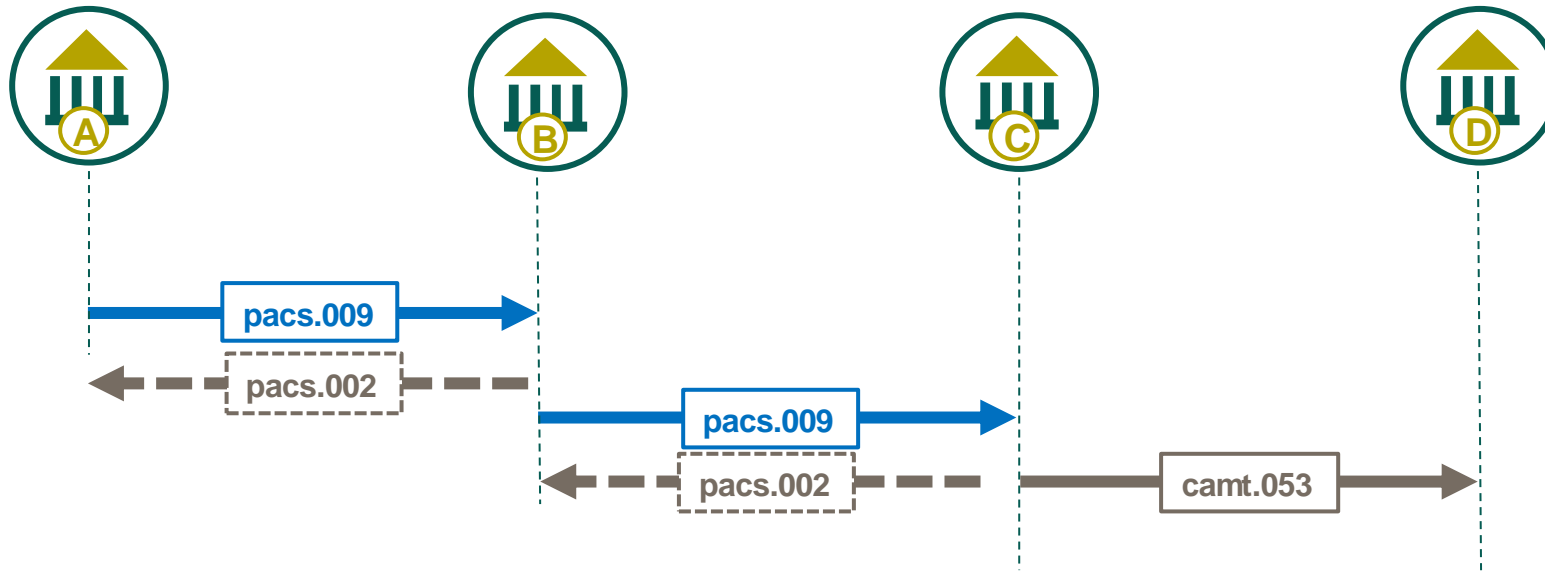

The Financial Institution Credit Transfer message is sent by a Debtor Financial Institution to a Creditor Financial Institution, directly or through other agents and/or a payment clearing and settlement system. It is used to move funds from a debtor account to a creditor, where both Debtor and Creditor are **Financial Institutions**.

Group Header



pac009 Financial Institution Credit Transfer - Message Identification

Min 1 – Max 1

Each ISO 20022 payment message has a **Message Identification** element, located in the Group Header. This **35 character** identifier is a point-to-point reference used to unambiguously identify the message.



For Payment Clearing and Settlement (pac009) messages the Message Identification has no exact equivalent in the legacy MT payment message. However, the MT 202 Sender's Reference (Field 20) could be considered a similar comparison where a pac009 message contains a single Transaction.



Each transaction's *Credit Transfer Transaction Information* contains a variety of nested *Payment Identification* elements to capture reference related to the individual transaction such as a UETR (Unique End-to-end Transaction Reference)

Group Header ➤ Message Identification

pac009 Financial Institution Credit Transfer – Creation DateTime

Min 1 – Max 1

The pac009 message **Creation Date** captures the date and time which the message was created.

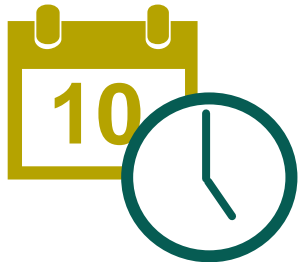

CBPR+ usage guidelines mandate the time zone that the time represents as an offset against Universal Time Coordinated (UTC):

Local time with UTC offset YYYY-MM-DDThh:mm:ss.sss+/-hh:mm

- For example: 2002-10-10T12:00:00-05:00 (noon/midday on 10 October 2002, Central Daylight Savings Time as well as Eastern Standard Time in the U.S.)



All CBPR+ time elements need offset against UTC. Milliseconds are optional.

pac009 Financial Institution Credit Transfer - Number of Transactions

Min 1 – Max 1

The pac009 message **Number of Transactions** captures the number of individual transaction contained within the message.



The number of transactions in CBPR+ payment usage guidelines is fixed to 1.



Single transactions in the CBPR+ payment usage guidelines enable a transaction to be managed and unlocks highly automated, frictionless, instant payments, supporting the next generation of innovation.

Group Header ▶ Number of Transactions

pac.009 Financial Institution Credit Transfer– Settlement Information

Min 1 – Max 1

The pac.009 **Settlement Method** element within the Group Header **Settlement Information**, includes one of the embedded codes to indicate how the payment message will be settled.

The **Settlement Method** element in the pac.009 allows a choice of an embedded code.



INDA indicate this Customer Credit Transfer will be settlement by the Instructed Agent (as the Account Servicing Institution) The account held at the Instructed Agent may captured in the dedicated **Settlement Account** element.

INGA indicate this Customer Credit Transfer has already been settlement by the Instructing Agent, who has credited the Account they service for the Instructed Agent (as an Account Owner). The account held by the Instructed Agent with the Instructing Agent may captured in the dedicated **Settlement Account** element.



Settlement Method code CLRG is not part of CBPR+ specifications but instead used in Market Infrastructure specification (HVPS+)

Group Header > Settlement Information > Settlement Method

pacs.009 FI to FI Customer Credit Transfer – Settlement Account

The pacs.009 message **Settlement Account** is a nested element as part of **Settlement Information**, this element identifies information related to an account used to settle the payment instruction.

Min 0 – Max 1

The **Settlement Account** identifies the account details maintained at the account servicing institution (Agent responsible for the settlement of the instruction as indicated in the **Settlement Method**)



Min 1 – Max 1 Identification identifies the account maintained at the Debtor Agent (Account Servicing Institution)

Min 0 – Max 1 Type uses the external Cash Account Type code list to identify the type of account

Min 0 – Max 1 Currency identifies the currency if the account

Min 0 – Max 1 Name identifies the name of the account as assigned by the Account Servicing Institution

Min 0 – Max 1 Proxy captures an alternative identification of the account number such as an email address. This element has further nested **Type** which is a choice of external code list or proprietary code and **Identification** which are both mandatory where the Proxy element is used.

Credit Transfer Transaction Information



pac.009 Financial Institution Credit Transfer - Payment Identification

Min 1 – Max 1

The pac.009 message **Payment Identification** provides a set of elements to identify the payment, of which several are mandatory elements

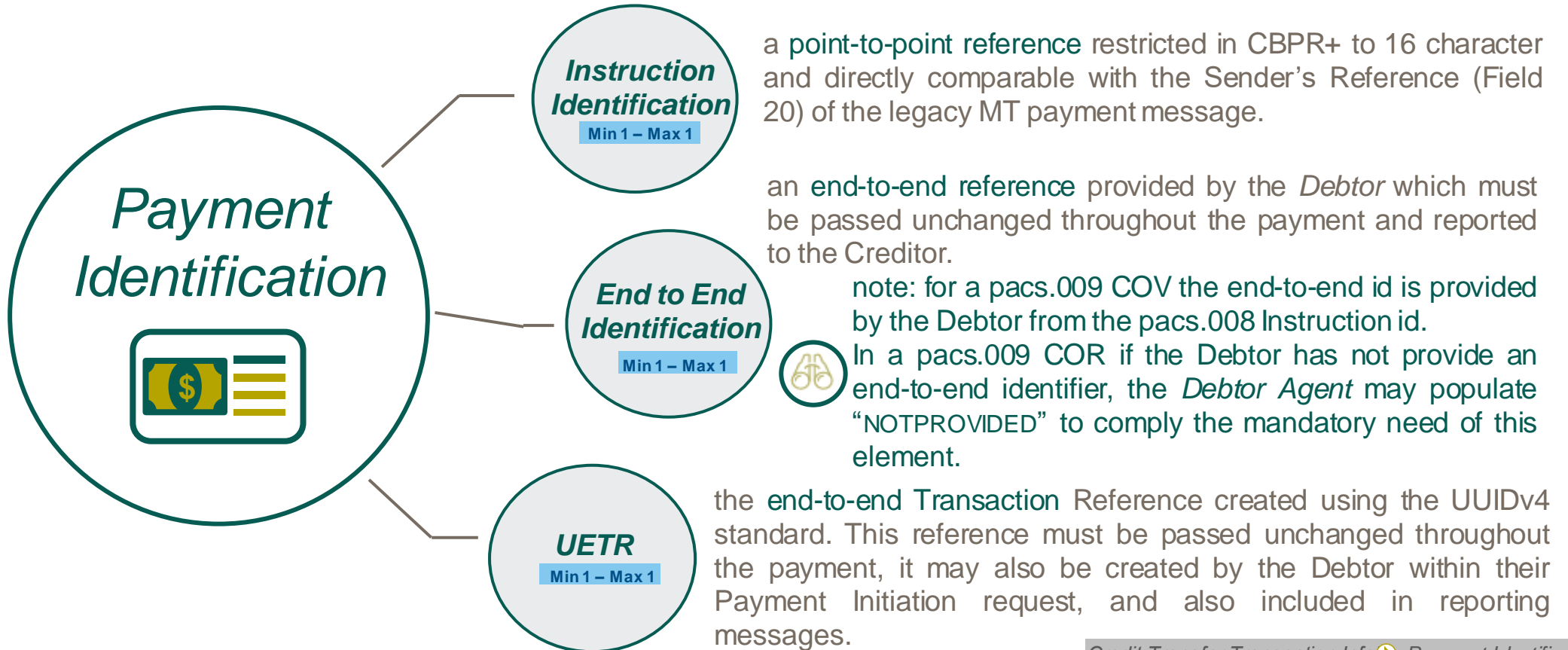

pac009 Financial Institution Credit Transfer - Payment Identification (continued)

Min 1 – Max 1

The pac009 message **Payment Identification** also provides a set of optional elements to identify the payment.

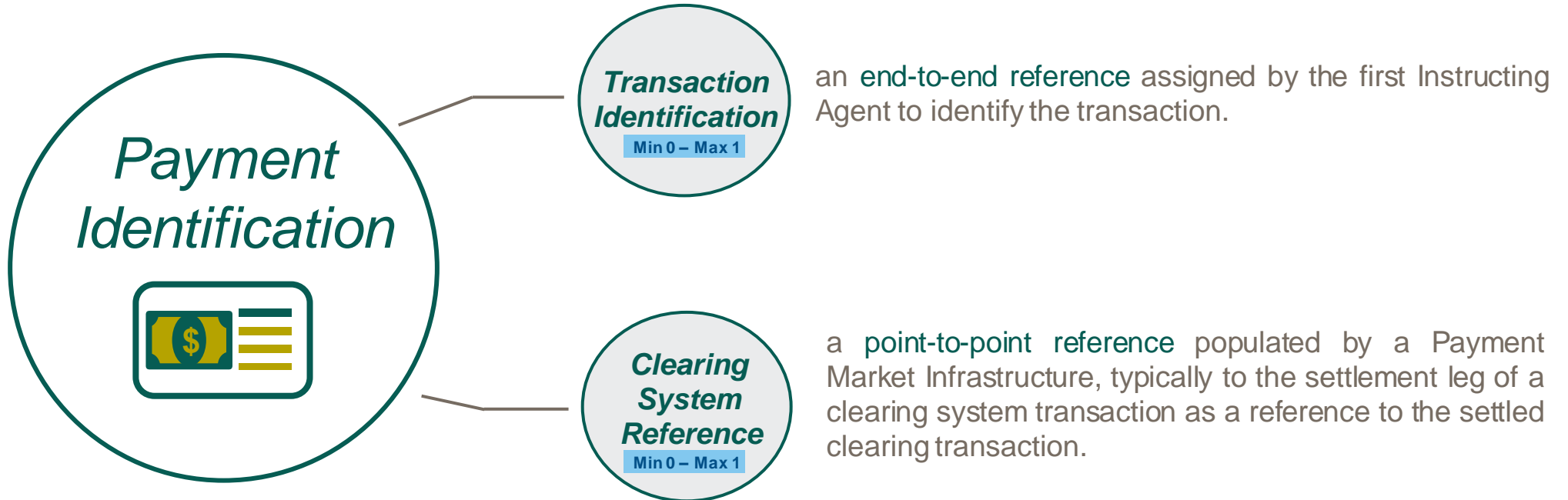

pacs.009 Financial Institution Credit Transfer - Payment Type Information

Min 0 – Max 1

The pacs message **Payment Type Information** provides a set of optional elements where the payment type can be described.

a choice of imbedded codes representing the urgency considered by the Instructing Agent, this point-to-point information may be used by the Instructed Agent to differentiate the processing priority.

Instruction Priority

Min 0 – Max 1

Service Level

Min 0 – Max 3

A nested element which may either use an external ISO Service Level code* or a proprietary code. It is used to identify a particular agreed service level which should be applied to the payment.

For example, code G001 can be used to identify a gpi Tracked Cover Transfer similarly to Field 111 value 001 in the MT 202 COV

Payment Type Information



Local Instrument

Min 0 – Max 1

A nested element which may either use an external ISO Local Instrument code or a proprietary code. It is used to identify the type of payment local instrument such as a Standing Order.



Note: the ISO instrument codes are registered by specific community group (captured in the code list)

Clearing Channel

Min 0 – Max 1

a choice of imbedded codes representing the clearing channel to be used to process the payment. e.g., RTGS

Category Purpose

Min 0 – Max 1

A nested element which may either use an external ISO Category Purpose code or a proprietary code. It is used to identify the category of payment. For example, SECU Transaction is the payment of securities.



*note - where a service level is not bilaterally agreed, it may be ignored.

pac.009 Financial Institution Credit Transfer– Interbank Settlement Amount and Date

The pac.009 message (unlike the pac.008) has only one element to capture the amount of the Credit Transfer, **Interbank Settlement Amount**.

Min 1 – Max 1



**Interbank
Settlement
Amount**

A mandated currency amount moved between the *Instructing Agent* and the *Instructed Agent*. This therefore is the point-to-point currency amount exchanged, comparable with the MT Field 32A

**Interbank
Settlement
Date**

Min 1 – Max 1

A mandated date on which the *Interbank Settlement* should be executed between the *Instructing Agent* and the *Instructed Agent*. This therefore is the **value date** comparable with the MT Field 32A



Note: the Financial Institution Credit Transfer (pac.009) has no *Instructed Amount* element, *Exchange Rate* or *Charger Bearer* (unlike the pac.008) as the Instructed Settlement Amount is expected to be transferred across the end-to-end payment chain without any charges being applied or currency conversions.



pac.009 Financial Institution Credit Transfer – Settlement Priority, Time Indication & Request

The pac.009 message has three optional elements to capture the optional information related to the settlement of the instructions.

Min 0 – Max 1



The **Settlement Priority** provides an optional choice of embedded codes to indicate the instruction's settlement priority from the perspective of the Instructing Agent. This point-to-point information may be used by the Instructed Agent to identify the priority associated with the **Settlement Method** and should not be confused with the **Instruction Priority**.



Note: Where the **Settlement Method** of the pac.009 is 'INDA' (settled performed by the Instructed Agent) this indicates the Settlement Priority. Code 'INGA' implies settlement has already occurred for this point-to-point payment and therefore the Settlement Priority is not necessary.

Min 0 – Max 1



The **Settlement Time Indication** optionally captures the time settlement occurred at a transaction administrator such as a Market Infrastructure.

This DateTime can be captured in two nested elements, **Debit Date Time** and **Credit Date Time**.

Min 0 – Max 1



The **Settlement Time Request** optionally captures the time settlement is requested for the payment instruction by the Instructing Agent. This Time can be capture in four nested elements:

- **CLS Time** the time the amount must be credit to CLS Bank
- **Till Time** the time until which the payment may be settled
- **From Time** the time from which the payment may be settled
- **Reject Time** the time from which the payment must be settled (to avoid reject)

Credit Transfer Transaction Information

pacs.009 Financial Institution Credit Transfer – Previous Instructing Agents

The pacs message can capture up to 3 Previous Instructing Agents, which represent an Agent who previously only played a dynamic role in the payment between the Debtor Agent and Creditor Agent.

Min 0 – Max 1

The **Previous Instructing Agent 1** captures the first historic Agent between the Debtor Agent and the Previous Instructing Agent 2 (where present) and the Instructing Agent. This optional element is comparable with the Field 72 first /INS/ occurrence in the legacy FIN message.



Min 0 – Max 1

The **Previous Instructing Agent 1 Account** captured the account related between this Agent and Previous Instructing Agent 2 (where present) or the Instructing Agent. This optional element has not comparable field in the legacy FIN message

Min 0 – Max 1

The **Previous Instructing Agent 2** captures the second Previous Instructing Agent between the Previous Instructing Agent 1 and the Previous Instructing Agent 3 (where present) and the Instructing Agent. This optional element is comparable with the Field 72 second /INS/ occurrence in the legacy FIN message.



Min 0 – Max 1

The **Previous Instructing Agent 2 Account** captured the account related between this Agent and Previous Instructing Agent 2 (where present) or the Instructing Agent. This optional element has not comparable field in the legacy FIN message.

Min 0 – Max 1

The **Previous Instructing Agent 3** captures the third Previous Instructing Agent between the Agent and the Instructing Agent. This optional element is comparable with the Field 72 third /INS/ occurrence in the legacy FIN message.

Min 0 – Max 1

The **Previous Instructing Agent 3 Account** captured the account related between this Agent and Previous Instructing Agent 2 (where present) or the Instructing Agent. This optional element has not comparable field in the legacy FIN message



Debtor Agent and Creditor Agent elements must be present before the previous **Instructing Agent 1** element can be used

pac009 Financial Institution Credit Transfer - Instructed and Instructing Agents

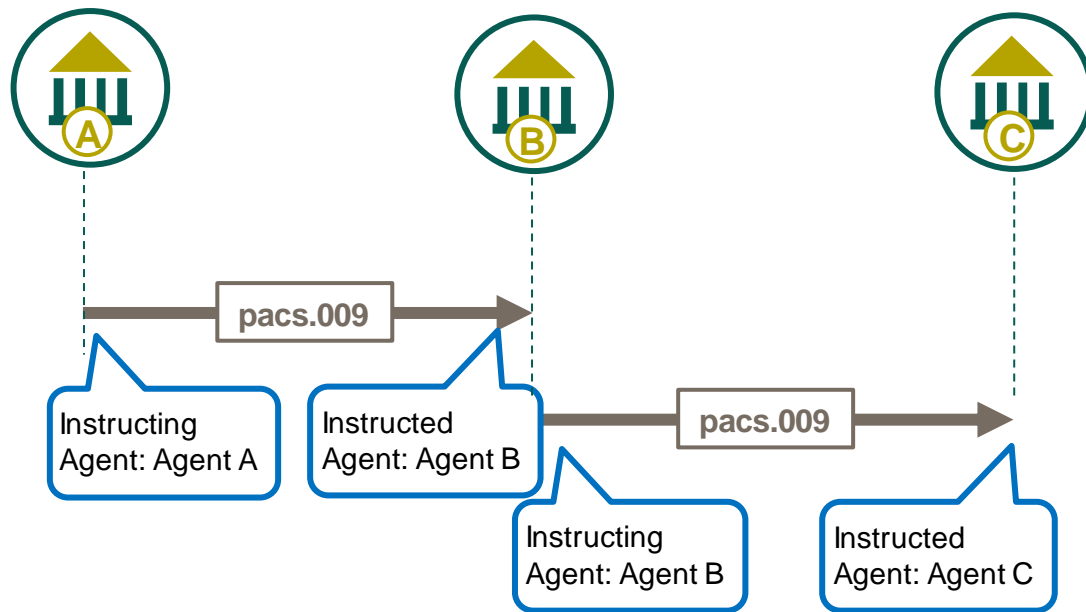

Instructing Agent and **Instructed Agent** represent the Agents involved in the pac009 point-to-point message exchange. These roles therefore change on each payment leg.



Instructing Agent and **Instructed Agent** elements are required in all pac009 messages and are only available in the **Credit Transfer Information**

Credit Transfer Transaction Information

➤ Instructing Agent

➤ Instructed Agent



pacs.009 Financial Institution Credit Transfer– Previous Instructing Agents versus Intermediary Agents

The ISO 20022 pacs messages have a number of optional Agent elements whose roles change throughout the life cycle of the payment. **Intermediary Agent** is an example of this, where these agents are classified in numeric order (i.e. *Intermediary Agent 1*) **Previous Instructing Agent** however is a static role which allows additional Previous Instructing Agent to be appended to the history of the payment.

The below diagram visualizes the change of Agent role at different stages of the payment transaction life cycle.

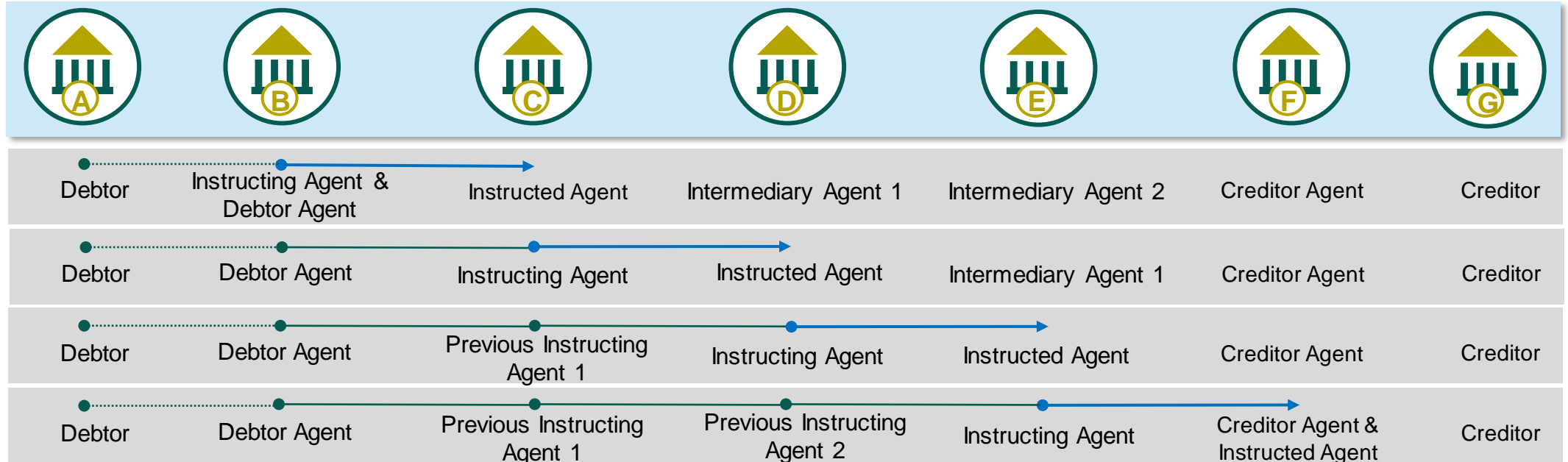

Note: the static roles of Previous Instructing Agent transition into Intermediary Agents in the potential return chain (refer to the pacs.004²⁶⁵ section for Payment Returns)

paces.009 Financial Institution Credit Transfer – Intermediary Agents

The pacs message can capture up to 3 Intermediary Agents, which play a dynamic role in the payment between the Debtor Agent and Creditor Agent.

Min 0 – Max 1

The **Intermediary Agent 1** captures the first Intermediary Agent between the Debtor Agent and Creditor Agent for who the Instructed Agent attempt to instruct the payment on to. This optional element is comparable with the Field 56a in the legacy FIN message.



Min 0 – Max 1

The **Intermediary Agent 1 Account** captured the account related to this Intermediary Agent, with the Instructed Agent. This element can be compared to the Party Identifier of the legacy Field 56a.

Min 0 – Max 1

The **Intermediary Agent 2** captures the second Intermediary Agent between the Intermediary Agent 1 and the Creditor Agent. This optional element has not comparable field in the legacy FIN message.



Min 0 – Max 1

The **Intermediary Agent 2 Account** captured the account related to this Intermediary Agent, with the Intermediary Agent 1. This optional element has not comparable field in the legacy FIN message.

Min 0 – Max 1

The **Intermediary Agent 3** captures the third Intermediary Agent between the Intermediary Agent 2 and the Creditor Agent. This optional element has not comparable field in the legacy FIN message.



Min 0 – Max 1

The **Intermediary Agent 3 Account** captured the account related to this Intermediary Agent, with the Intermediary Agent 2. This optional element has not comparable field in the legacy FIN message.



Debtor Agent and Creditor Agent elements must be present before the **Intermediary Agent 1** element can be used

pac.009 Financial Institution Credit Transfer– Debtor

The ISO 2022 pac.009 messages describe the Agent whose account is debited for a transaction as the **Debtor**. The *Debtor* sub elements describe the *Debtor* in greater detail.

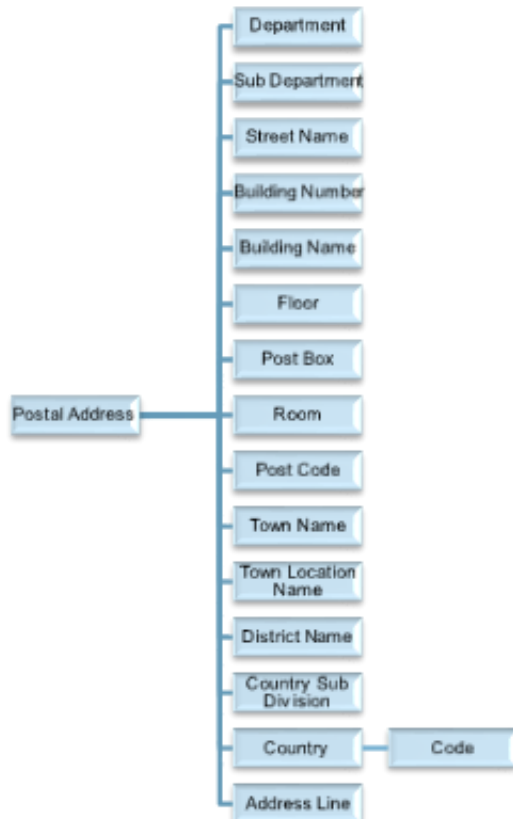

Information used to identify a Debtor by a clearing system identifier.

The BIC which identifies the *Debtor*

Legal entity identifier of the financial institution.

Name by which the Agent is known

Nested element capturing either structured or unstructured *Debtor* address details

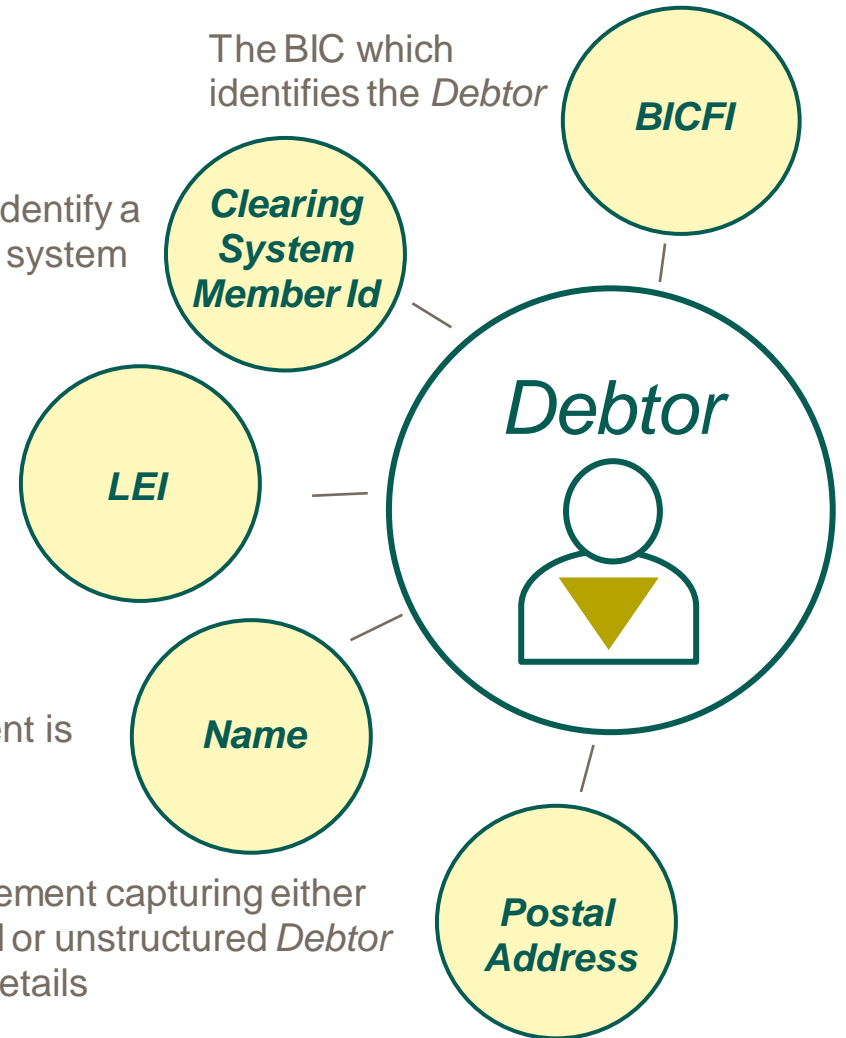

The Debtor of the pac.009 where used to settle a pac.009 ADV remains the original Debtor of the pac.009 ADV to provide party transparency.

pac.009 Financial Institution Credit Transfer – Debtor Account

Min 0 – Max 1

The pac.009 **Debtor Account** is used to capture the account information for which debit entry is/has been applied to the Debtor's account, which are also reflected in their account Statement.

The **Debtor Account** uses a variety of nested elements to capture information related to the account.



Min 1 – Max 1 Identification identifies the account maintained at the Debtor Agent (Account Servicing Institution)

Min 0 – Max 1 Type uses the external Cash Account Type code list to identify the type of account

Min 0 – Max 1 Currency identifies the currency of the account

Min 0 – Max 1 Name identifies the name of the account as assigned by the Debtor Agent (Account Servicing Institution)

Min 0 – Max 1 Proxy captures an alternative identification of the account number such as an email address. This element has further nested **Type** which is a choice of external code list or proprietary code and **Identification** which are both mandatory where the Proxy element is used.



the pac.009 the Debtor is a Financial Institution, therefore the nested elements **Name** and **Proxy** are unlikely to be used.



pac.009 Financial Institution Credit Transfer– Debtor Agent and Creditor Agent

Min 0 – Max 1

Min 0 – Max 1

The **Debtor Agent** and **Creditor Agent** are static roles in the pac.009 FI to FI Customer Credit Transfer. These agents maintain a relationship with their customers; the **Debtor** and **Creditor**. However, unlike the pac.008 Debtor Agent and Creditor Agent, which are optional, which cover the scenario where the Debtor and Creditor (as Financial Institutions) maintain a direct Nostro/Vostro account relationship.



Note: Where the **Debtor** and **Creditor** maintain a relationship with the same intermediary counterpart. It is recommended that this Agent is captured in the **Creditor Agent** element to align with translation from the legacy MT message.

Credit Transfer Transaction Information 

 Debtor Agent

 Creditor Agent

pac.009 Financial Institution Credit Transfer – Debtor Agent Account and Creditor Agent Account

Min 0 – Max 1

The pac.009 **Debtor Agent Account** and **Creditor Agent Account** is used to capture the account information related to these Agents. The nature of this element implies there is an Agent or Agent in between the Debtor Agent and Creditor Agent in the payment transaction.

The **Debtor Agent Account** and **Creditor Agent Account** uses a variety of nested elements to capture information related to the account.



Min 1 – Max 1

Identification identifies the account maintained at the Creditor Agent (Account Servicing Institution)

Min 0 – Max 1

Type uses the external Cash Account Type code list to identify the type of account

Min 0 – Max 1

Currency identifies the currency of the account

Min 0 – Max 1

Name identifies the name of the account as assigned by the Creditor Agent (Account Servicing Institution)

Min 0 – Max 1

Proxy captures an alternative identification of the account number such as an email address. This element has further nested **Type** which is a choice of external code list or proprietary code and **Identification** which are both mandatory where the Proxy element is used.



Debtor Agent and Creditor Agent are Financial Institutions, therefore the nested elements **Name** and **Proxy** are unlikely to be used.



pac.009 Financial Institution Credit Transfer– Creditor

The ISO 2022 pac messages describe the Agent whose account is credited for a transaction as the **Creditor**. The *Creditor* sub elements describe the *Creditor* in greater detail.

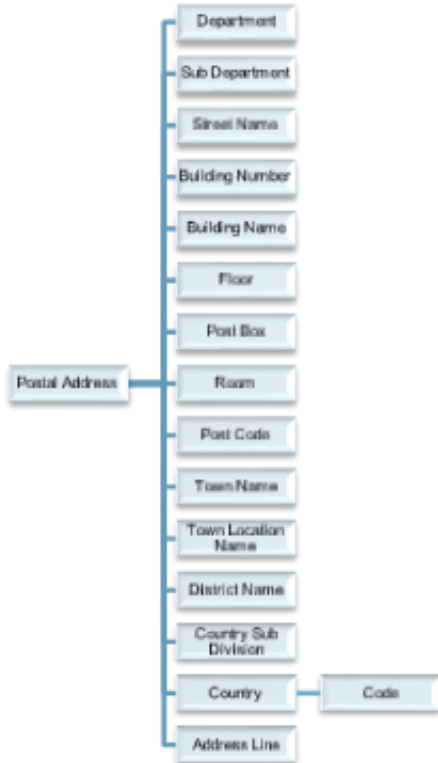

Information used to identify a Debtor by a clearing system identifier.

Legal entity identifier of the financial institution.

Name by which the Agent is known

Nested element capturing either structured or unstructured *Debtor* address details

The BIC which identifies the *Creditor*

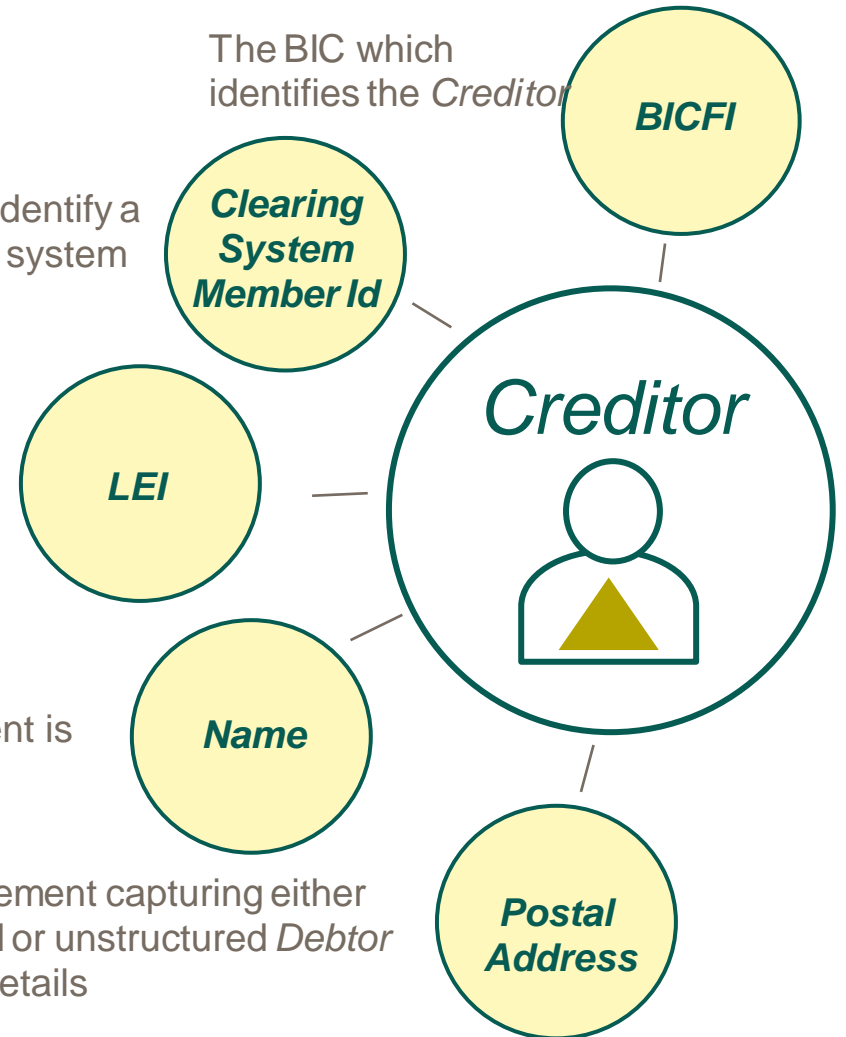

Certain legacy MT messages, such as the MT200, identify the Creditor from the message sender, whereas this party would need to be repeated in the pac.009

pac.009 Financial Institution Credit Transfer – Creditor Account

Min 0 – Max 1

The pac.009 **Creditor Account** is used to capture the account information for which a credit entry is intended to be applied to the Creditor's account, which are also reflected in their account Statement.

The **Creditor Account** uses a variety of nested elements to capture information related to the account.



Min 1 – Max 1 Identification identifies the account maintained at the Creditor Agent (Account Servicing Institution)

Min 0 – Max 1 Type uses the external Cash Account Type code list to identify the type of account

Min 0 – Max 1 Currency identifies the currency of the account

Min 0 – Max 1 Name identifies the name of the account as assigned by the Creditor Agent (Account Servicing Institution)

Min 0 – Max 1 Proxy captures an alternative identification of the account number such as an email address. This element has further nested **Type** which is a choice of external code list or proprietary code and **Identification** which are both mandatory where the Proxy element is used.



the pac.009 the Creditor is a Financial Institution, therefore the nested elements **Name** and **Proxy** are unlikely to be used.



pac.009 Financial Institution Credit Transfer– Instruction For elements

The **Instruction for Next Agent** and **Instruction for Creditor Agent** elements within the pac.009 Financial Institution Credit Transfer optionally provides information related to the processing of the payment for these Agents.



Min 0 – Max 2

The **Instruction for Creditor Agent** element offers a multiplicity of up to 2 occurrences of information. This element enables:

- the use of 2 embedded **codes** to describe the instruction
- free format *instruction information*
- or both, where the free format complements the code.

The use of this element may be **bilaterally** agreed with the *Creditor Agent*. It must be passed on throughout the life cycle of the transaction until the payment reaches the *Credit Agent*.



The Creditor of the pac.009 ADV is captured in the pac.009 (used to settle the pac.009 ADV) Instruction for Creditor Agent, Instruction Information element preceded by /UDLC/ (UnDerLYing Creditor) to provide party transparency in the settlement message.

Min 0 – Max 6



The **Instruction for Next Agent** element offers a multiplicity of up to 6 occurrences of information. This element is restricted to free format *instruction information* in CBPR+. The element is used to provide instruction to the next Agent (which may not be the Creditor Agent)

Credit Transfer Transaction Information 

 Instruction for Creditor Agent

 Instruction for Next Agent

pac.009 Financial Institution Credit Transfer– Instruction for Creditor Agent

Min 0 – Max 2

An **Instruction for Creditor Agent** elements within the pac.009 Financial Institution Credit Transfer, used to settle a pac.009 Financial Institution Credit Transfer Advice (ADV), provides information related to the Creditor in the advice message (Underlying Creditor).

The **Creditor** of the pac.009 ADV are commonly captured in one of the following ways:

- As a BIC (**BICFI**) either on its own, or
- As a **Clearing System Member Identification** or a **LEI** with **Name**, and **Postal Address**



pac.009 **Instruction for Creditor Agent/Instruction Information.**

Up to 2 occurrences of Instruction Information may be provided. The last available occurrence of **Instruction Information**, preceded by /UDLC/, must be used to capture the Underlying Creditor provided in the pac.009 ADV.



pac.009 ADV Creditor/Financial Institution		Data example
BICFI		ABCDGB22
Clearing System Member Identification	Clearing System Identification	GBDSC
	Member Identification	205050
LEI		123456A1BCDEFG2T54
Name		ABC BANK
Address	Various Structured elements	252 HIGH STREET LONDON EC1 1WX GB
	Address Line (unstructured)	252 HIGH STREET LONDON EC1 1WX GB

pac.009 Instruction for Creditor Agent/Instruction Information
/UDLC/ABCDGB22
OR
/UDLC/ABC BANK LONDON GB
OR
/UDLC/ABC BANK LONDON EC1 1WX GB

BICFI only.

Name and structured **Postal Address** (TownName and Country Code should be prioritised).

Name and unstructured **Address Line** (TownName and Country Code should be prioritised, where possible).

BICFI is preferred, alternatively, **Name** and **Postal Address** should be prioritised.



pac.009 Financial Institution Credit Transfer – Purpose

Min 0 – Max 1

The **Purpose** elements within the pac.009 Financial Institution Credit Transfer capture the reason for the payment transaction which may either use an external ISO **Purpose code** or a proprietary code.

The purpose is used by the capture the nature of the payment e.g., **CORT** Trade Settlement Payment, **CFFC** Cancellation Fees etc. and should not be confused with Regulatory Reporting codes present in the pac.008.



The externalised Purpose code set is classified by the purpose, for example commercial, for which the numerous codes within the classification are each described by Name and Definition.

For example:

OTCD is classified within the Collateral categorisation, with the *Name* **OTC Derivatives** described as a **Cash collateral related to over-the-counter (OTC) Derivatives** - in general for example contracts which are traded and privately negotiated.



Category Purpose also captures a high level purpose, which unlike *Purpose* is less granular but can trigger special processing e.g., Category Purpose code **SECU** ‘Securities’ may trigger pac.002 *Payment Status Report* to provide update on the progress of the payment to the previous Agent.

Credit Transfer Transaction Information 

 Purpose

paces.009 Financial Institution Credit Transfer – Remittance Information

The optional **Remittance Information** element within the paces.009 Financial Institution Credit Transfer is nested to provide **Unstructured** information related to payment.

Min 0 – Max 1

Remittance Information enable the matching/reconciliation of an entry that the payment is intended to settle



Min 0 – Max 1

The **Unstructured** sub element captures free format *Remittance Information* which is restricted in CBPR+ to 140 characters to ensure backward compatibility with the legacy MT message during coexistence.



Note: unlike the paces.008 *Remittance Information* can only be captured in an *Unstructured* element in the paces.009 Financial Institution Credit Transfer. **Remittance Information** is however a dedicated element used both within the paces and camt reporting messages, whereby this information can travel end-to-end using ISO 20022.

Credit Transfer Transaction Info  Remittance Information 

Unstructured

Index of pacs.009 Use Cases

Use case should be considered as a principal example whereby use case may be cross referenced e.g. a use case involving a Market Infrastructure can apply the Market Infrastructure legs to other use cases.

Serial Financial Institution Payments

Use Case p.9.1.1 – High Level Financial Institution Credit Transfer (pacs.009) settled over a Payment Market Infrastructure

Use Case p.9.1.2 - High Level Financial Institution Credit Transfer (pacs.009) pre-advised settled using pacs.009.

High Level Financial Institution Credit Transfer (pacs.009) settled over a Payment Market Infrastructure

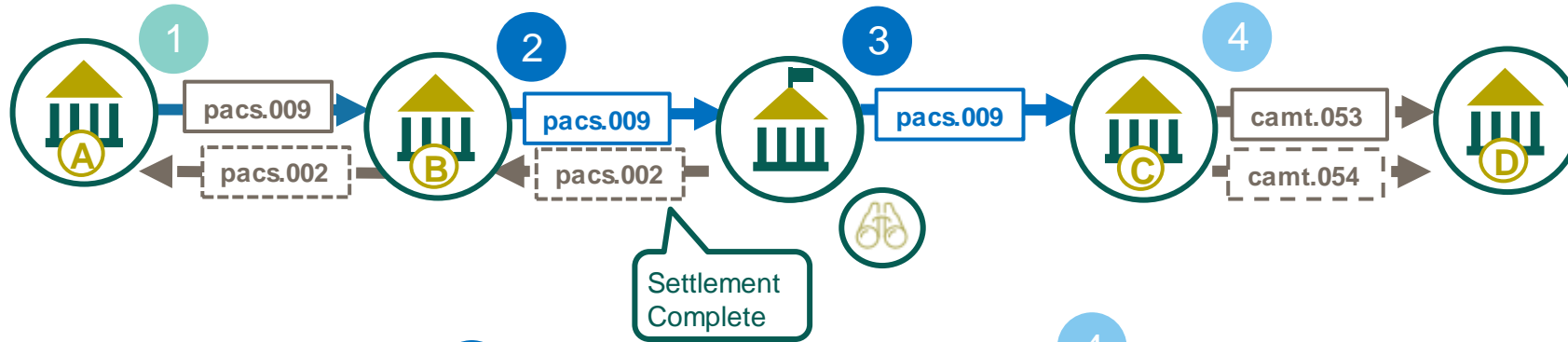

1 Debtor initiates a payment instruction to the Debtor Agent

2 Agent B processes the payment on Agent C, via the Payment Market Infrastructure.

3 Payment Market Infrastructure, settles the payment between Agent B and Agent C as direct participants of the Market Infrastructure, and provides a settlement confirmation to Agent B

4 Agent C credits the account of the Creditor (Agent D), and may optionally provide a notification e.g. credit notification in addition to an account statement (camt.054) in addition to a customer statement (camt.053)



High Level Financial Institution Credit Transfer (pacs.009) pre-advised using pacs.009 (advice)

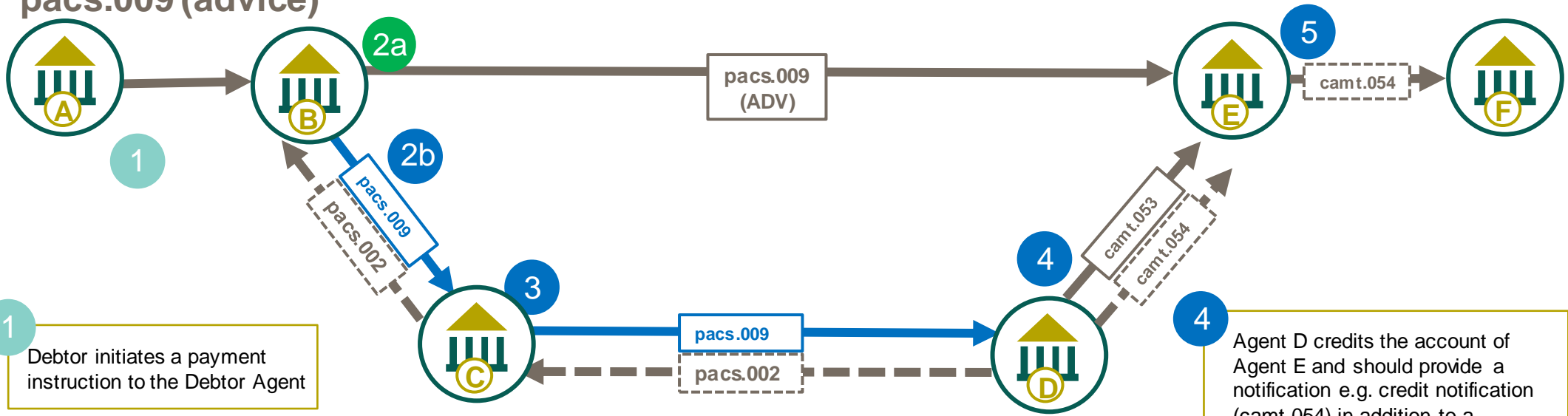

1 Debtor initiates a payment instruction to the Debtor Agent

2a Debtor Agent (B) provided a notification to Creditor Agent (E) using a pacs.009 advice to indicate a 'pre-advise and provides the related payment details (in step 2b) This provides Agent E the ability to take the payment amount into their position, particularly where final settlement in step 5 occur after their business day. (i.e. time zone differences between the various Agent in the payment chain.

2b In parallel the Debtor Agent (B) initiates a payment to credit the account of Agent (E) as the creditor in the pacs.009 settlement message

3 Agent C processes the payment on to Agent D

4 Agent D credits the account of Agent E and should provide a notification e.g. credit notification (camt.054) in addition to a customer statement (camt.053)

5 Agent E receives the payment and credits the account of Agent F as the Creditor, and may optionally provide a notification e.g. credit notification.



Note: the pacs.009 ADV only operates in a direct advice message to the Creditor Agent (Agent E above) with the pacs.009 used to settle this Agent.

pacs.009 (adv)

Financial Institution Credit Transfer



pac.009 Advice

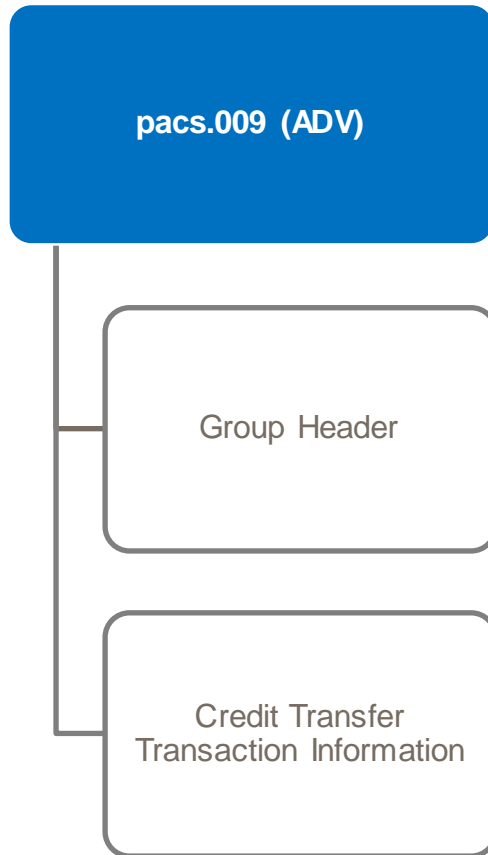

The pac.009 advice is used to pre-advise an Agent of a fund movement toward the Creditor.

The core pac.009 is used to perform the settlement of this pre-advice message.

High Level message flow

pacs.009

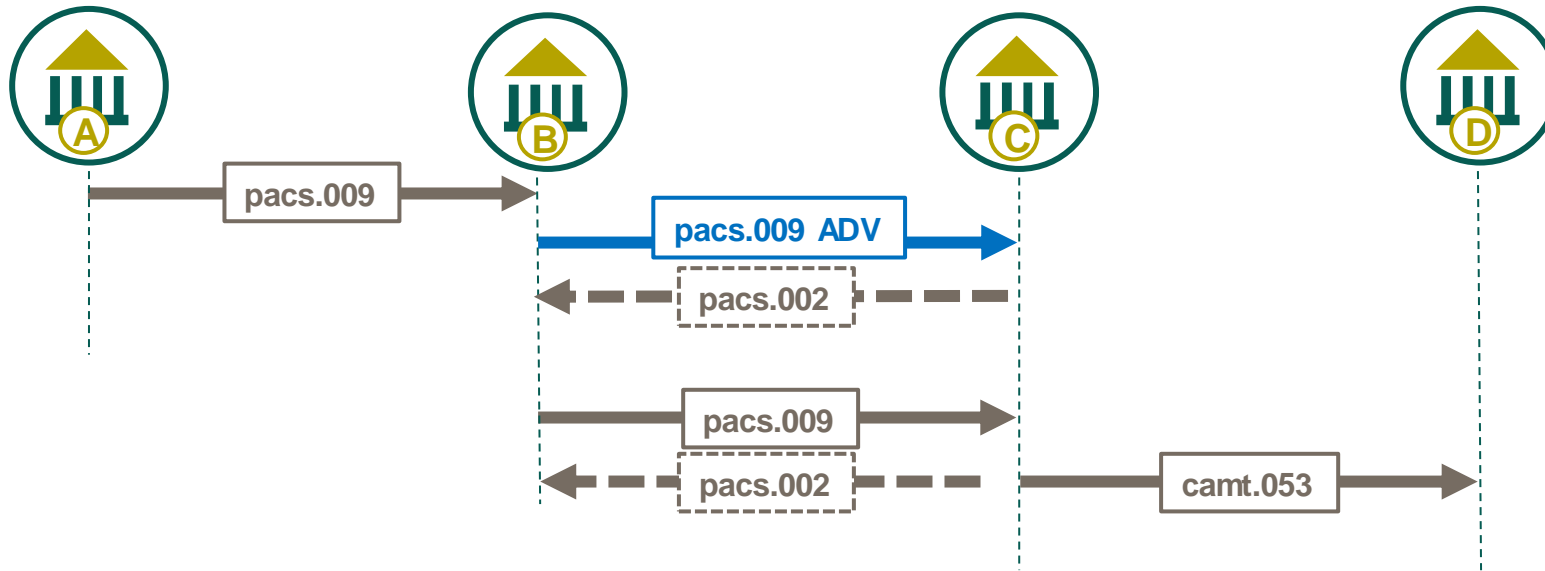

The Financial Institution Credit Transfer (advice) message is sent by a Debtor Agent to a Creditor Agent, directly. In this context the pacs.009 ADV is used as a direct advice message.

It is used to move funds from a debtor account to a creditor, where both Debtor and Creditor are **Financial Institutions**.



To provide party transparency in the pacs.009 ADV, the **Debtor** of the pacs.009 ADV remains the Debtor of the pacs.009 used to settle the pacs.009 ADV.

The **Creditor** of the pacs.009 ADV is captured in the pacs.009 (used to settle the pacs.009 ADV) Instruction for Creditor Agent, Instruction Information element preceded by /UDLC/ (UnDerLying Creditor).

Group Header



pac009 (ADV) Financial Institution Credit Transfer - Message Identification

Min 1 – Max 1

Each ISO 20022 payment message has a **Message Identification** element, located in the Group Header. This **35 character** identifier is a point-to-point reference used to unambiguously identify the message.



For Payment Clearing and Settlement (pac009) messages the Message Identification has no exact equivalent in the legacy MT payment message. However, the MT 202 Sender's Reference (Field 20) could be considered a similar comparison where a pac009 message contains a single Transaction.



Each transaction's **Credit Transfer Transaction Information** contains a variety of nested **Payment Identification** elements to capture reference related to the individual transaction such as a UETR (Unique End-to-end Transaction Reference)

Group Header ➤ Message Identification

pac009 (ADV) Financial Institution Credit Transfer – Creation DateTime

Min 1 – Max 1

The pac009 message **Creation Date** captures the date and time which the message was created.

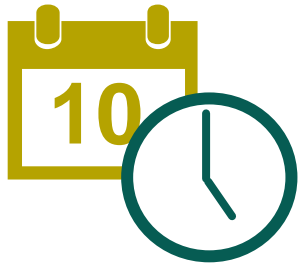

CBPR+ usage guidelines mandate the time zone that the time represents as an offset against Universal Time Coordinated (UTC):

Local time with UTC offset `YYYY-MM-DDThh:mm:ss.sss+/-hh:mm`

- For example: `2002-10-10T12:00:00-05:00` (noon/midday on 10 October 2002, Central Daylight Savings Time as well as Eastern Standard Time in the U.S.)



All CBPR+ time elements need offset against UTC. Milliseconds are optional.

pac.009 (ADV) Financial Institution Credit Transfer - Number of Transactions

Min 1 – Max 1

The pac.009 message **Number of Transactions** captures the number of individual transaction contained within the message.



The number of transactions in CBPR+ payment usage guidelines is fixed to 1.



Single transactions in the CBPR+ payment usage guidelines enable a transaction to be managed and unlocks highly automated, frictionless, instant payments, supporting the next generation of innovation.

Group Header ▶ Number of Transactions

pac.009 (ADV) Financial Institution Credit Transfer - Settlement Method

Min 1 – Max 1

The pac.009 **Settlement Method** element within the Group Header **Settlement Information**, includes one of the embedded codes to indicate how the payment message will be settled.



The **Settlement Method** element in the pac.009 ADV is fixed to **COVE**. This indicates that this advice of Financial Institution Credit Transfer will be settled using a covering pac.009.

Like the pac.008, the Agents being used in the covering payment to reimburse the Instructed Agent can be provided in the dedicated Reimbursement Agent elements. This allows the Instructed Agent to identify the debit account on their books from the Reimbursement Agent account or look up the account related to the reimbursement agent.

pac.009 (ADV) Financial Institution Credit Transfer – Reimbursement Agents

The pac.009 message captures a number of Reimbursement Agents as a sub element to **Settlement Information** these elements detail the Agent in the cover method who will process the pac.009 cover. These elements are similar in nature to the Field 53, 54 and 55 in legacy MT messages and are referred to as The **Instructing Reimbursement Agent**, and **Instructed Reimbursement Agent**. Each of these reimbursement agents also has a dedicated account element to optionally capture their related account details.

Min 0 – Max 1

The **Instructing Reimbursement Agent** captures the Agent who will execute a covering payment (i.e. pac.009 COV or domestic equivalent) often referred to as the currency correspondent. This optional element is comparable with the Field 53a in the legacy FIN message.

Min 0 – Max 1

The **Instructing Reimbursement Agent Account** captured the account related to this Reimbursement Agent. This element can be compared to the Party Identifier of the legacy Field 53.

Min 0 – Max 1

The **Instructed Reimbursement Agent** captures the Agent who will receive the covering payment (i.e., pac.009 cov or domestic equivalent) and credit the account of the pac.008 FI to FI Customer Credit Transfer **Instructed Agent**. This optional element is comparable with the Field 54a in the legacy FIN message.

Min 0 – Max 1

The **Instructed Reimbursement Agent Account** captured the account related to this Reimbursement Agent. This element can be compared to the Party Identifier of the legacy Field 54.



Credit Transfer Transaction Information



paces.009 (ADV) Financial Institution Credit Transfer - Payment Identification

Min 1 – Max 1

The pacs message **Payment Identification** provides a set of elements to identify the payment, of which several are mandatory elements

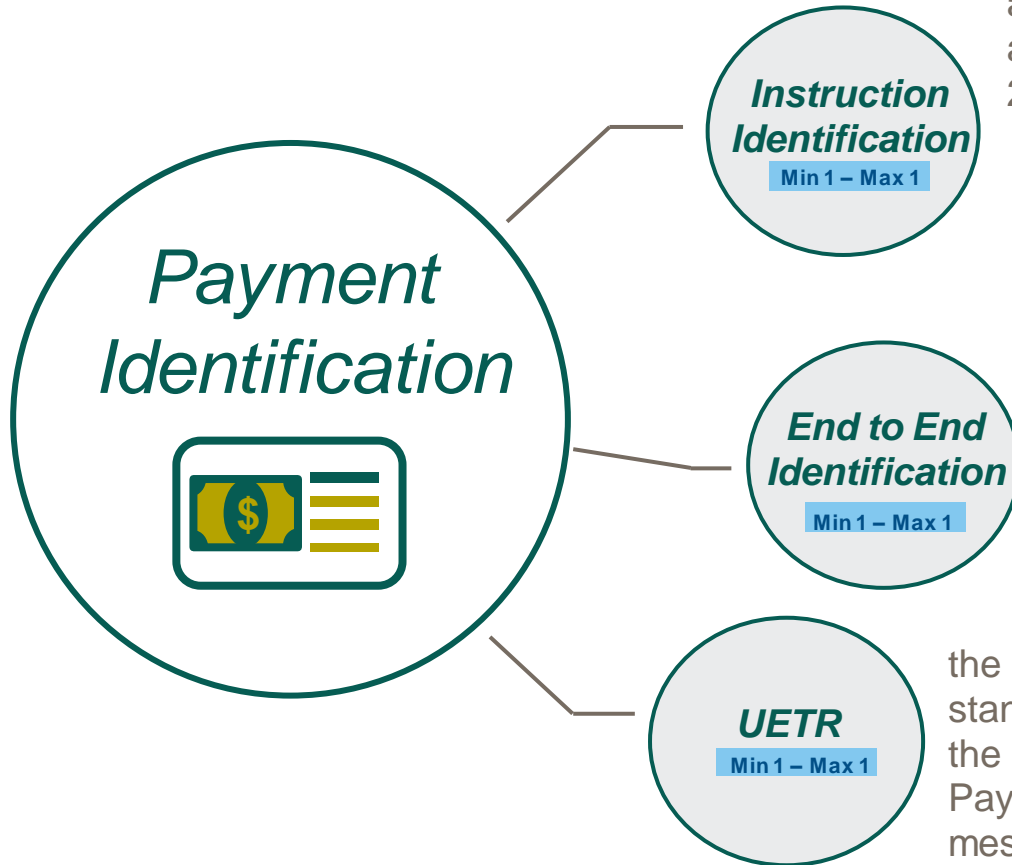

a point-to-point reference restricted in CBPR+ to 16 character and directly comparable with the Sender's Reference (Field 20) of the legacy MT payment message.



Note: this reference must be transported in the *End-to-End Identification* of the pacs.009 message used to settle the pacs.009 ADV

an end-to-end reference provided by the *Debtor* which must be passed unchanged throughout the payment and reported to the Creditor.



note: In a pacs.009 ADV if the Debtor has not provide an end-to-end identifier, the *Debtor Agent* may populate "NOTPROVIDED" to comply the mandatory need of this element.

the end-to-end Transaction Reference created using the UUIDv4 standard. This reference must be passed unchanged throughout the payment, it may also be created by the Debtor within their Payment Initiation request, and also included in reporting messages.



pac009 (ADV) Financial Institution Credit Transfer - Payment Identification (continued)

Min 1 – Max 1

The pac0 message **Payment Identification** also provides a set of optional elements to identify the payment.

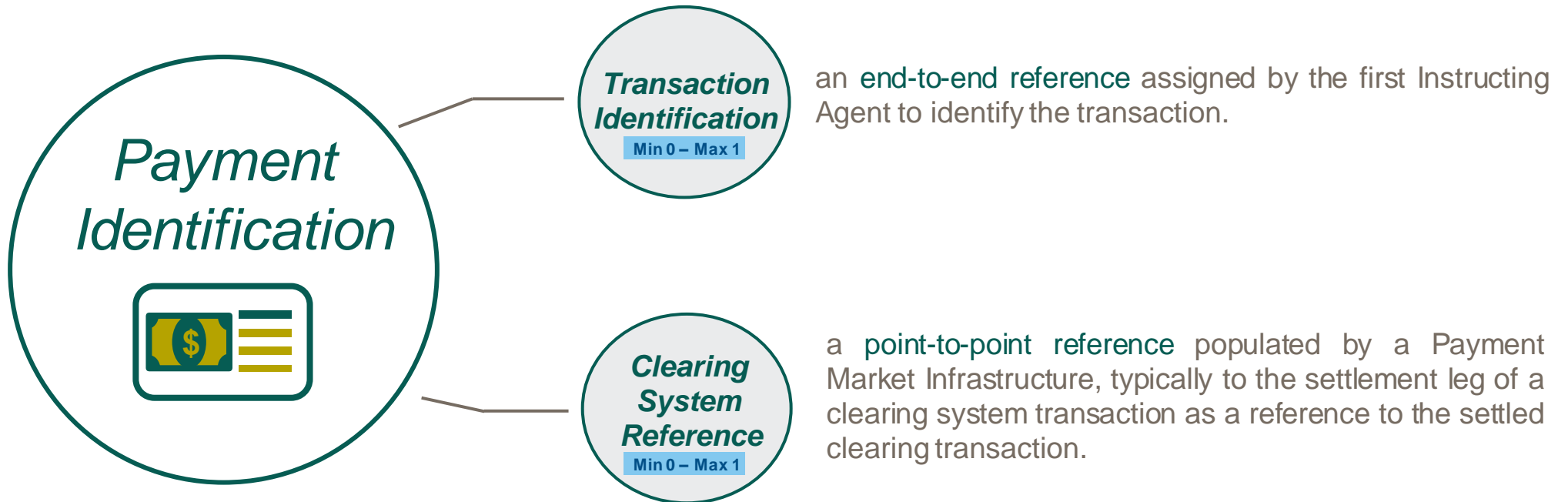

pacs.009 (ADV) Financial Institution Credit Transfer - Payment Type Information

Min 0 – Max 1

The pacs message **Payment Type Information** provides a set of optional elements where the payment type can be described.

a choice of imbedded codes representing the urgency considered by the Instructing Agent, this point-to-point information may be used by the Instructed Agent to differentiate the processing priority.

Instruction Priority

Min 0 – Max 1

Service Level

Min 0 – Max 3

A nested element which may either use an external ISO Service Level code* or a proprietary code. It is used to identify a particular agreed service level which should be applied to the payment.

For example, code G001 can be used to identify a gpi Tracked Cover Transfer similarly to Field 111 value 001 in the MT 202 COV

Payment Type Information



Local Instrument

Min 0 – Max 1

A nested element which may either use an external ISO Local Instrument code or a proprietary code. It is used to identify the type of payment local instrument such as a Standing Order.



Note: the ISO instrument codes are registered by specific community group (captured in the code list)

Clearing Channel

Min 0 – Max 1

a choice of imbedded codes representing the clearing channel to be used to process the payment. e.g., RTGS

Category Purpose

Min 0 – Max 1

A nested element which may either use an external ISO Category Purpose code or a proprietary code. It is used to identify the category of payment. For example, SECU Transaction is the payment of securities.



*note - where a service level is not bilaterally agreed, it may be ignored.

pacs.009 (ADV) Financial Institution Credit Transfer– Currency, Amount and Date

The pacs.009 message (unlike the pacs.008) has only one element to capture the amount of the Credit Transfer, **Interbank Settlement Amount**.

Min 1 – Max 1



Interbank Settlement Amount

A mandated currency amount moved between the *Instructing Agent* and the *Instructed Agent*. This therefore is the point-to-point currency amount exchanged, comparable with the MT Field 32A

Interbank Settlement Date

A mandated date on which the *Interbank Settlement* should be executed between the *Instructing Agent* and the *Instructed Agent*. This therefore is the **value date** comparable with the MT Field 32A



Note: the Financial Institution Credit Transfer (pacs.009) has no *Instructed Amount* element, *Exchange Rate* or *Charger Bearer* (unlike the pacs.008) as the Instructed Settlement Amount is expected to be transferred across the end-to-end payment chain without any charges being applied or currency conversions.



pac.009 (ADV) - Financial Institution Credit Transfer – Settlement Priority, Time Indication & Request

The pac.009 message has three optional elements to capture the optional information related to the settlement of the instructions.

Min 0 – Max 1



The **Settlement Priority** provides an optional choice of embedded codes to indicate the instruction's settlement priority from the perspective of the Instructing Agent. This point-to-point information may be used by the Instructed Agent to identify the priority associated with the **Settlement Method** and should not be confused with the **Instruction Priority**.



Note: As the **Settlement Method** of the pac.009 (ADV) is 'COVE' (settled via a covering pac.009) Settlement Priority is relevant to the covering payment not the pac.009 ADV

Min 0 – Max 1



The **Settlement Time Indication** optionally captures the time settlement occurred at a transaction administrator such as a Market Infrastructure.

This DateTime can be captured in two nested elements, **Debit Date Time** and **Credit Date Time**.

Min 0 – Max 1



The **Settlement Time Request** optionally captures the time settlement is requested for the payment instruction by the Instructing Agent. This Time can be capture in four nested elements:

- **CLS Time** the time the amount must be credit to CLS Bank
- **Till Time** the time until which the payment may be settled
- **From Time** the time from which the payment may be settled
- **Reject Time** the time from which the payment must be settled (to avoid reject)

Credit Transfer Transaction Information

pac.009 (ADV) Financial Institution Credit Transfer - Instructed and Instructing Agents

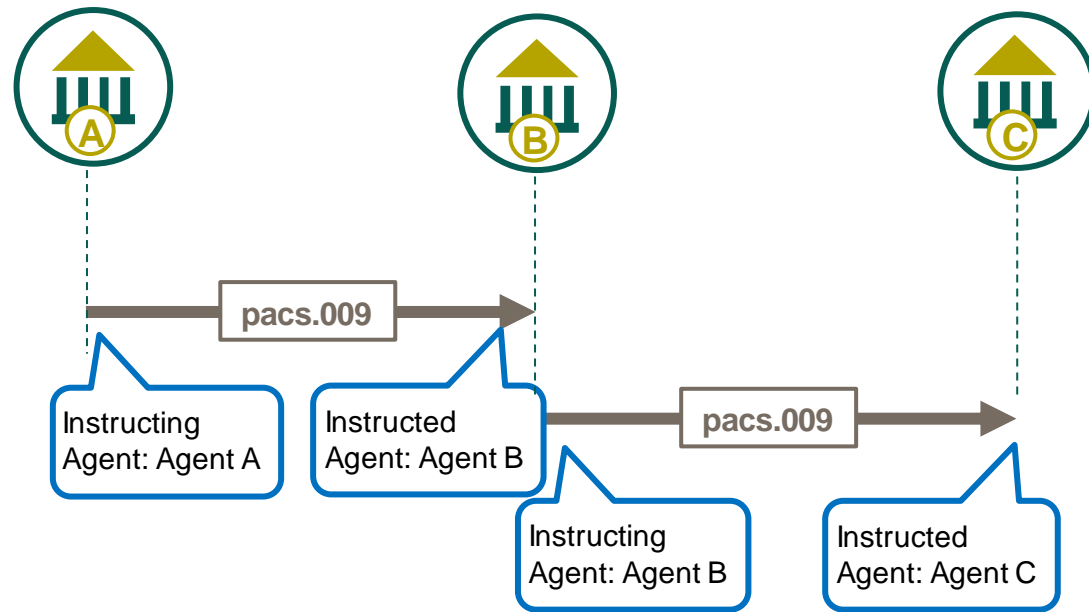

Instructing Agent and **Instructed Agent** represent the Agents involved in the pac.009 point-to-point message exchange. These roles therefore change on each payment leg.



Instructing Agent and *Instructed Agent* elements are required in all pac.009 messages and are only available in the **Credit Transfer Information**

Credit Transfer Transaction Information

- Instructing Agent
- Instructed Agent



pac009 (ADV) Financial Institution Credit Transfer– Previous Instructing Agents versus Intermediary Agents



Unlike the other pac009 messages in the CBPR+ collection, the pac009 ADV message is exchanged directly between the Debtor Agent (as an Instructing Agent) and Creditor Agent (as an Instructed Agent). The roles of previous Instructing Agents and Intermediary Agents are therefore irrelevant in the pac009 (ADV)

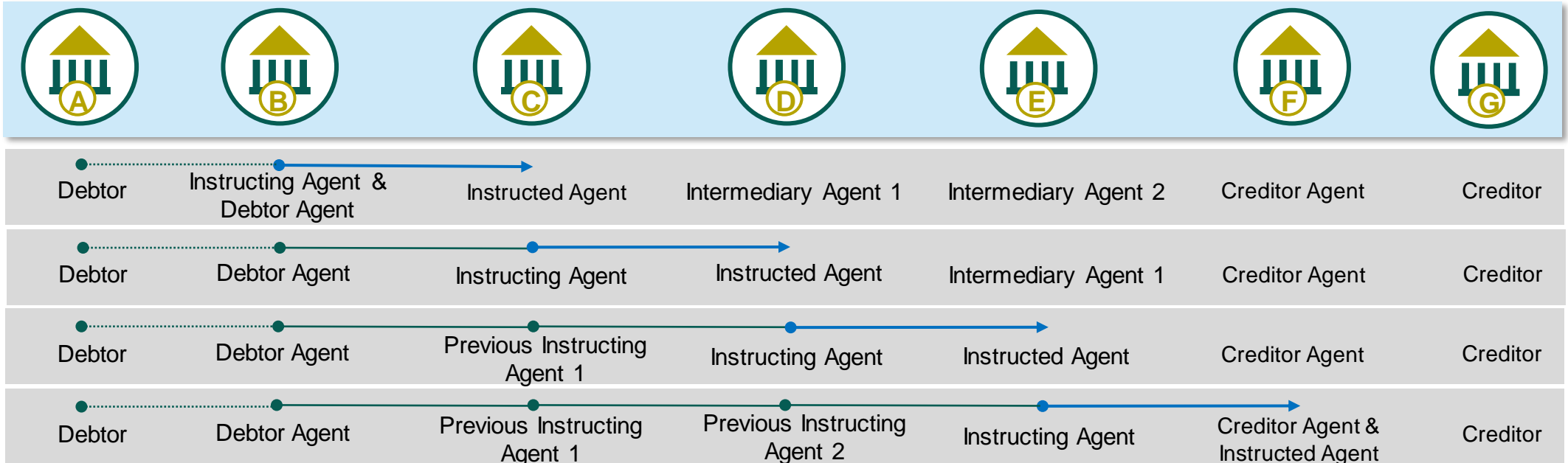

pac.009 (ADV) Financial Institution Credit Transfer– Debtor

The ISO 2022 pac.009 messages describe the Agent whose account is debited for a transaction as the **Debtor**. The *Debtor* sub elements describe the *Debtor* in greater detail.

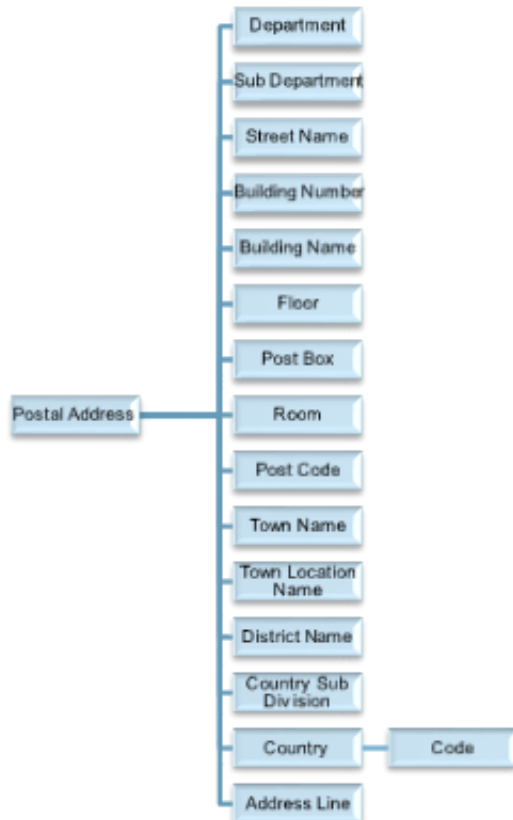

Information used to identify a Debtor by a clearing system identifier.

Legal entity identifier of the financial institution.

Name by which the Agent is known

Nested element capturing either structured or unstructured *Debtor* address details

The BIC which identifies the *Debtor*

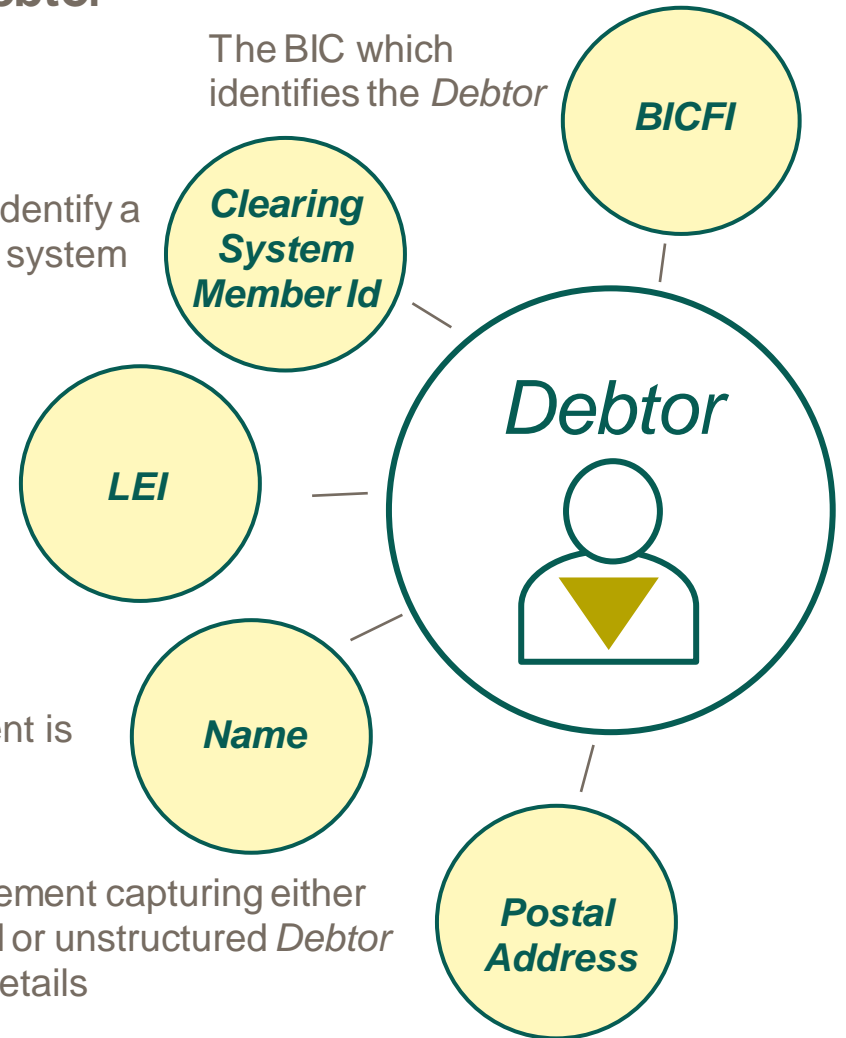

The Debtor of the pac.009 ADV remains the Debtor of the pac.009 used to settled the pac.009 ADV to provide party transparency.

pac.009 (ADV) Financial Institution Credit Transfer – Debtor Account

Min 0 – Max 1

The pac.009 **Debtor Account** is used to capture the account information for which debit entry is/has been applied to the Debtor's account, which are also reflected in their account Statement.

The **Debtor Account** uses a variety of nested elements to capture information related to the account.



Min 1 – Max 1 Identification identifies the account maintained at the Debtor Agent (Account Servicing Institution)

Min 0 – Max 1 Type uses the external Cash Account Type code list to identify the type of account

Min 0 – Max 1 Currency identifies the currency of the account

Min 0 – Max 1 Name identifies the name of the account as assigned by the Debtor Agent (Account Servicing Institution)

Min 0 – Max 1 Proxy captures an alternative identification of the account number such as an email address. This element has further nested **Type** which is a choice of external code list or proprietary code and **Identification** which are both mandatory where the Proxy element is used.



the pac.009 the Debtor is a Financial Institution, therefore the nested elements **Name** and **Proxy** are unlikely to be used.



pac.009 (ADV) Financial Institution Credit Transfer– Debtor Agent and Creditor Agent

Min 0 – Max 1

Min 0 – Max 1

The **Debtor Agent** and **Creditor Agent** are static roles in the pac.009 FI to FI Customer Credit Transfer. These agents maintain a relationship with their customers; the **Debtor** and **Creditor**. However, unlike the pac.008 Debtor Agent and Creditor Agent, which are optional, which cover the scenario where the Debtor and Creditor (as Financial Institutions) maintain a direct Nostro/Vostro account relationship.



Note: Where the **Debtor** and **Creditor** maintain a relationship with the same intermediary counterpart. It is recommended that this Agent is captured in the **Creditor Agent** element to align with translation from the legacy MT message.

Credit Transfer Transaction Information 

 Debtor Agent

 Creditor Agent

pac.009 (ADV) Financial Institution Credit Transfer – Debtor Agent Account and Creditor Agent Account

Min 0 – Max 1

The pac.009 **Debtor Agent Account** and **Creditor Agent Account** is used to capture the account information related to these Agents. The nature of this element implies there is an Agent or Agent in between the Debtor Agent and Creditor Agent in the payment transaction.

The **Debtor Agent Account** and **Creditor Agent Account** uses a variety of nested elements to capture information related to the account.



Min 1 – Max 1

Identification identifies the account maintained at the Creditor Agent (Account Servicing Institution)

Min 0 – Max 1

Type uses the external Cash Account Type code list to identify the type of account

Min 0 – Max 1

Currency identifies the currency of the account

Min 0 – Max 1

Name identifies the name of the account as assigned by the Creditor Agent (Account Servicing Institution)

Min 0 – Max 1

Proxy captures an alternative identification of the account number such as an email address. This element has further nested **Type** which is a choice of external code list or proprietary code and **Identification** which are both mandatory where the Proxy element is used.



Debtor Agent and Creditor Agent are Financial Institutions, therefore the nested elements **Name** and **Proxy** are unlikely to be used.



pac009 (ADV) Financial Institution Credit Transfer– Creditor

The ISO 2022 pac009 messages describe the Agent whose account is credited for a transaction as the **Creditor**. The *Creditor* sub elements describe the *Creditor* in greater detail.

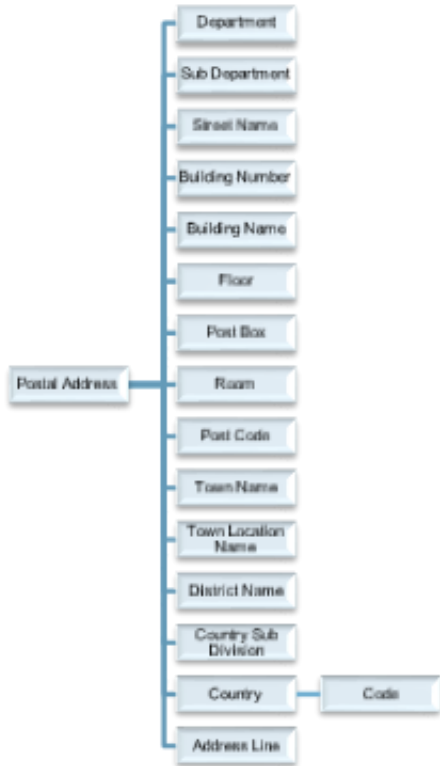

Information used to identify a Debtor by a clearing system identifier.

Legal entity identifier of the financial institution.

Name by which the Agent is known

Nested element capturing either structured or unstructured Debtor address details

The BIC which identifies the *Creditor*



The *Creditor* of the pac009 ADV is captured in the pac009 (used to settle the pac009 ADV) Instruction for Creditor Agent, Instruction Information element preceded by /UDLC/ (UnDerLying Creditor) to provide party transparency in the settlement message.



Certain legacy MT messages, such as the MT 200, identify the *Creditor* from the message sender, whereas this party would need to be repeated in the pac009

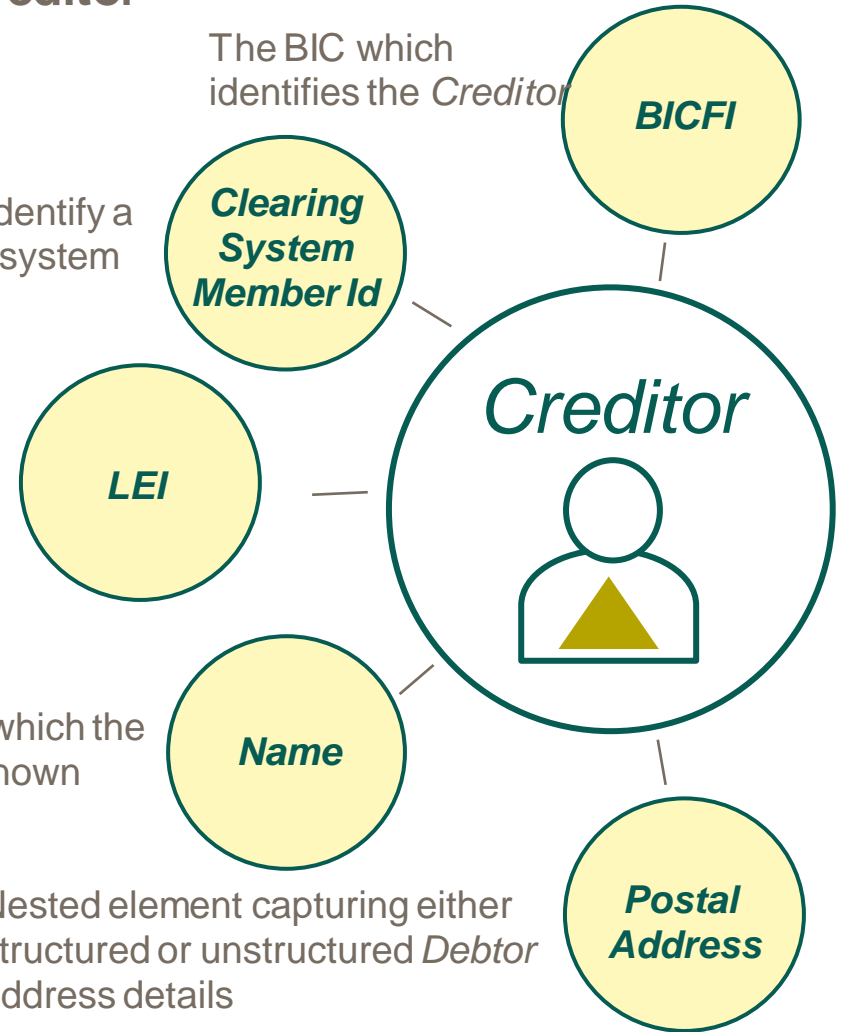

pac.009 (ADV) Financial Institution Credit Transfer – Creditor Account

Min 0 – Max 1

The pac.009 **Creditor Account** is used to capture the account information for which a credit entry is intended to be applied to the Creditor's account, which are also reflected in their account Statement.

The **Creditor Account** uses a variety of nested elements to capture information related to the account.



Min 1 – Max 1 Identification identifies the account maintained at the Creditor Agent (Account Servicing Institution)

Min 0 – Max 1 Type uses the external Cash Account Type code list to identify the type of account

Min 0 – Max 1 Currency identifies the currency of the account

Min 0 – Max 1 Name identifies the name of the account as assigned by the Creditor Agent (Account Servicing Institution)

Min 0 – Max 1 Proxy captures an alternative identification of the account number such as an email address. This element has further nested **Type** which is a choice of external code list or proprietary code and **Identification** which are both mandatory where the Proxy element is used.



For the pac.009 the Creditor is a Financial Institution, therefore the nested elements **Name** and **Proxy** are unlikely to be used.



pacs.009 (ADV) Financial Institution Credit Transfer– Instruction For elements

The **Instruction for Next Agent** and **Instruction for Creditor Agent** elements within the pacs.009 Financial Institution Credit Transfer optionally provides information related to the processing of the payment for these Agents.



Min 0 – Max 2

The **Instruction for Creditor Agent** element offers a multiplicity of up to 2 occurrences of information. This element enables:

- the use of 2 **embedded codes** to describe the instruction
- free format *instruction information*
- or both, where the free format complements the code.

The use of this element may be **bilaterally** agreed with the *Creditor Agent*. It must be passed on throughout the life cycle of the transaction until the payment reaches the *Credit Agent*.



Min 0 – Max 6

The **Instruction for Next Agent** element offers a multiplicity of up to 6 occurrences of information. This element is restricted to free format *instruction information* in CBPR+. The element is used to provide instruction to the next Agent (which may not be the Creditor Agent)

Credit Transfer Transaction Information

Instruction for Creditor Agent

Instruction for Next Agent

pac.009 (ADV) Financial Institution Credit Transfer – Purpose

Min 0 – Max 1

The **Purpose** elements within the pac.009 Financial Institution Credit Transfer capture the reason for the payment transaction which may either use an external ISO **Purpose code** or a proprietary code.

The purpose is used by the capture the nature of the payment e.g. **CORT** Trade Settlement Payment, **CFFC** Cancellation Fees etc. and should not be confused with Regulatory Reporting codes present in the pac.008.



The externalised Purpose code set is classified by the purpose, for example commercial, for which the numerous codes within the classification are each described by Name and Definition.

For example:

OTCD is classified within the Collateral categorisation, with the *Name* **OTC Derivatives** described as a **Cash collateral related to over-the-counter (OTC) Derivatives** - in general for example contracts which are traded and privately negotiated.



Category Purpose also captures a high level purpose, which unlike *Purpose* is less granular but can trigger special processing e.g. Category Purpose code **SECU** ‘Securities’ may trigger pac.002 *Payment Status Report* to provide update on the progress of the payment to the previous Agent.

Credit Transfer Transaction Information 

 Purpose

pacs.009 (ADV) Financial Institution Credit Transfer – Remittance Information

The optional **Remittance Information** element within the pacs.009 Financial Institution Credit Transfer is nested to provide **Unstructured** information related to payment.

Min 0 – Max 1

Remittance Information enable the matching/reconciliation of an entry that the payment is intended to settle



Min 0 – Max 1

The **Unstructured** sub element captures free format *Remittance Information* which is restricted in CBPR+ to 140 characters to ensure backward compatibility with the legacy MT message during coexistence.



Note: unlike the pacs.008 *Remittance Information* can only be captured in an *Unstructured* element in the pacs.009 Financial Institution Credit Transfer. **Remittance Information** is however a dedicated element used both within the pacs and camt reporting messages, whereby this information can travel end-to-end using ISO 20022.

Credit Transfer Transaction Info  Remittance Information 

Unstructured

Index of pacs.009 (ADV) Use Cases

Use case should be considered as a principal example whereby use case may be cross referenced e.g. a use case involving a Market Infrastructure can apply the Market Infrastructure legs to other use cases.

Financial Institution Advice Payments

Use Case p.9.1.2.a - High Level Financial Institution Credit Transfer (pacs.009) pre-advised using pacs.009 (advice)

Use Case p.9.1.2.b - High Level Financial Institution Credit Transfer (pacs.009) pre-advised using pacs.009 (advice)

High Level Financial Institution Credit Transfer (pacs.009) pre-advised using pacs.009 (advice)

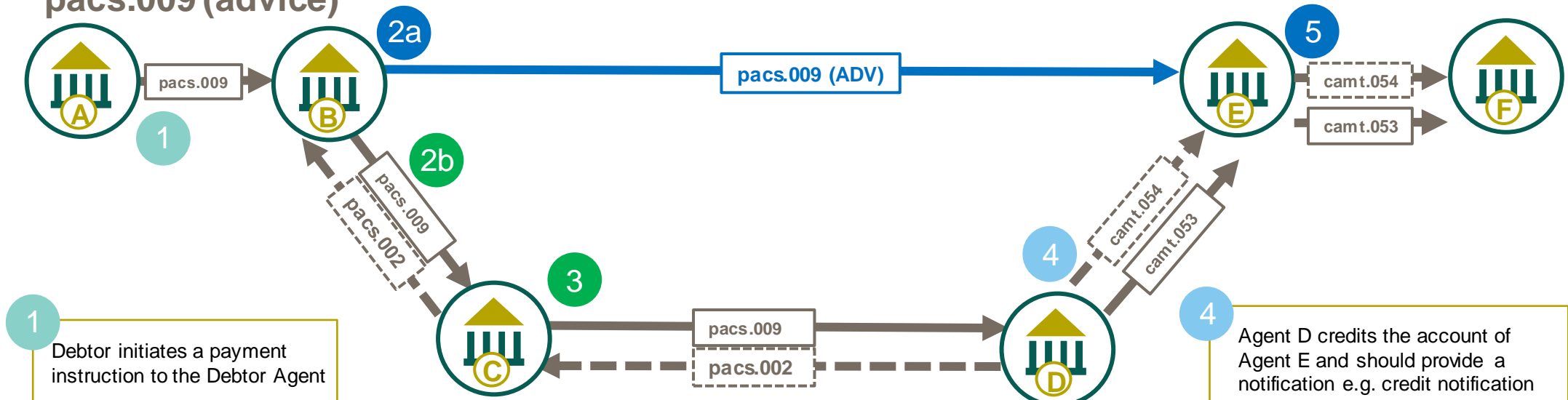

1 Debtor initiates a payment instruction to the Debtor Agent

2a Debtor Agent (B) provided a notification to Creditor Agent (E) using a pacs.009 advice to indicate a 'pre-advise and provides the related payment details (in step 2b) This provides Agent E the ability to take the payment amount into their position, particularly where final settlement in step 5 occur after their business day. (i.e. time zone differences between the various Agent in the payment chain.

2b In parallel the Debtor Agent (B) initiates a payment to credit the account of Agent (E) as the creditor in the pacs.009 settlement message

3 Agent C processes the payment on to Agent D

4 Agent D credits the account of Agent E and should provide a notification e.g. credit notification (camt.054) in addition to a customer statement (camt.053)

5 Agent E receives the payment and credits the account of Agent F as the Creditor, and may optionally provide a notification e.g. credit notification.



Note: the pacs.009 ADV only operates in a direct advice message to the Creditor Agent (Agent E above) with the pacs.009 used to settle this Agent.

High Level Financial Institution Credit Transfer (pacs.009) pre-advised using pacs.009 (advice)

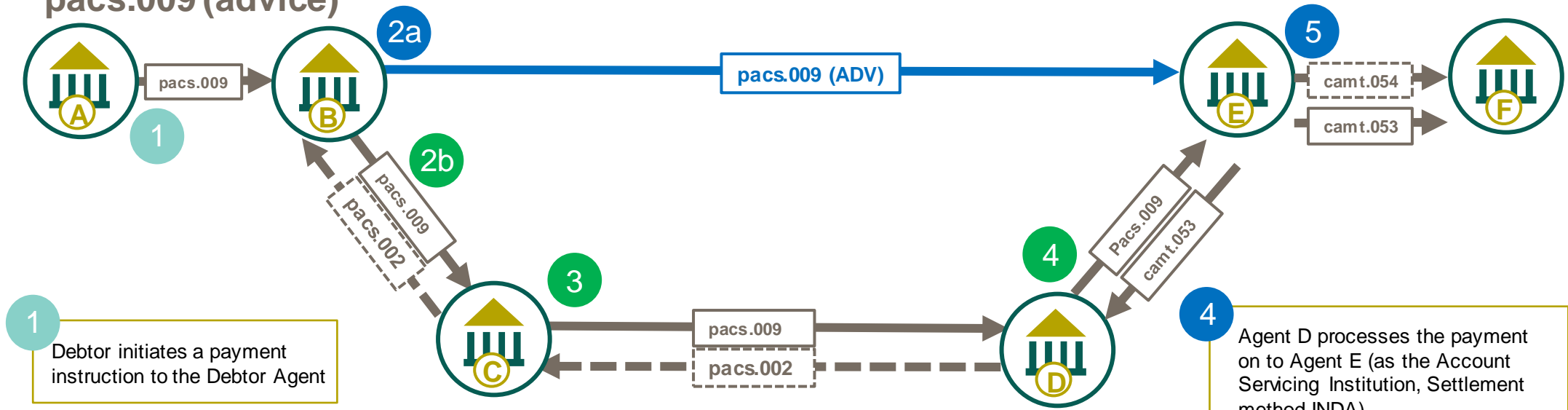

1 Debtor initiates a payment instruction to the Debtor Agent

2a Debtor Agent (B) provided a notification to Creditor Agent (E) using a pacs.009 advice to indicate a 'pre-advise and provides the related payment details (in step 2b) This provides Agent E the ability to take the payment amount into their position, particularly where final settlement in step 5 occur after their business day. (i.e. time zone differences between the various Agent in the payment chain.

2b In parallel the Debtor Agent (B) initiates a payment to credit the account of Agent (E) as the creditor in the pacs.009 settlement message

3 Agent C processes the payment on to Agent D

4 Agent D processes the payment on to Agent E (as the Account Servicing Institution, Settlement method INDA)

5 Agent E receives the payment and credits the account of Agent F as the Creditor, and may optionally provide a notification e.g. credit notification.



Note: the pacs.009 ADV only operates in a direct advice message to the Creditor Agent (Agent E above) with the pacs.009 used to settle this Agent.

pacs.009 (COV)

Financial Institution Credit Transfer (Cover)



pac.009 core versus cov

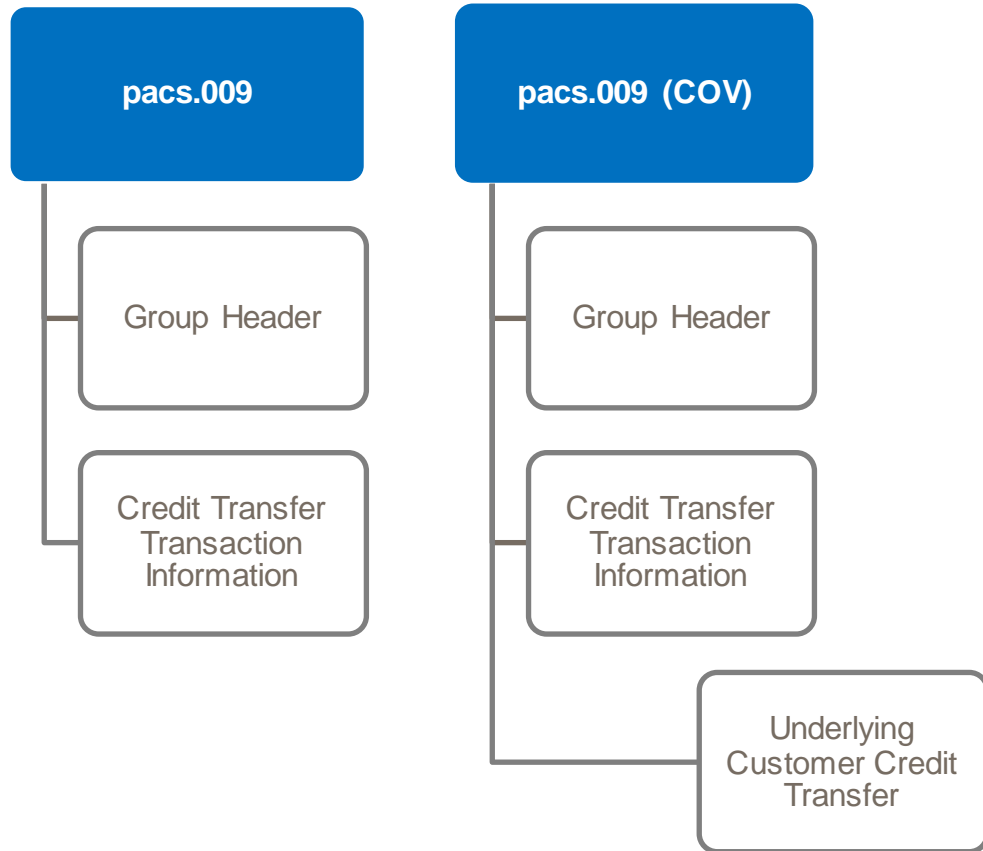

The pac.009 has two main use cases:

- as a core Financial Institution Credit Transfer message
- As a **COV** where it is used as cover of (to settle) a pac.008.

The pac.009 therefore contain information of the underlying Customer Credit Transfer (pac.008) for use in the cover scenario, which is the key attribute to differentiate between these two use cases.

High Level message flow

pacs.009

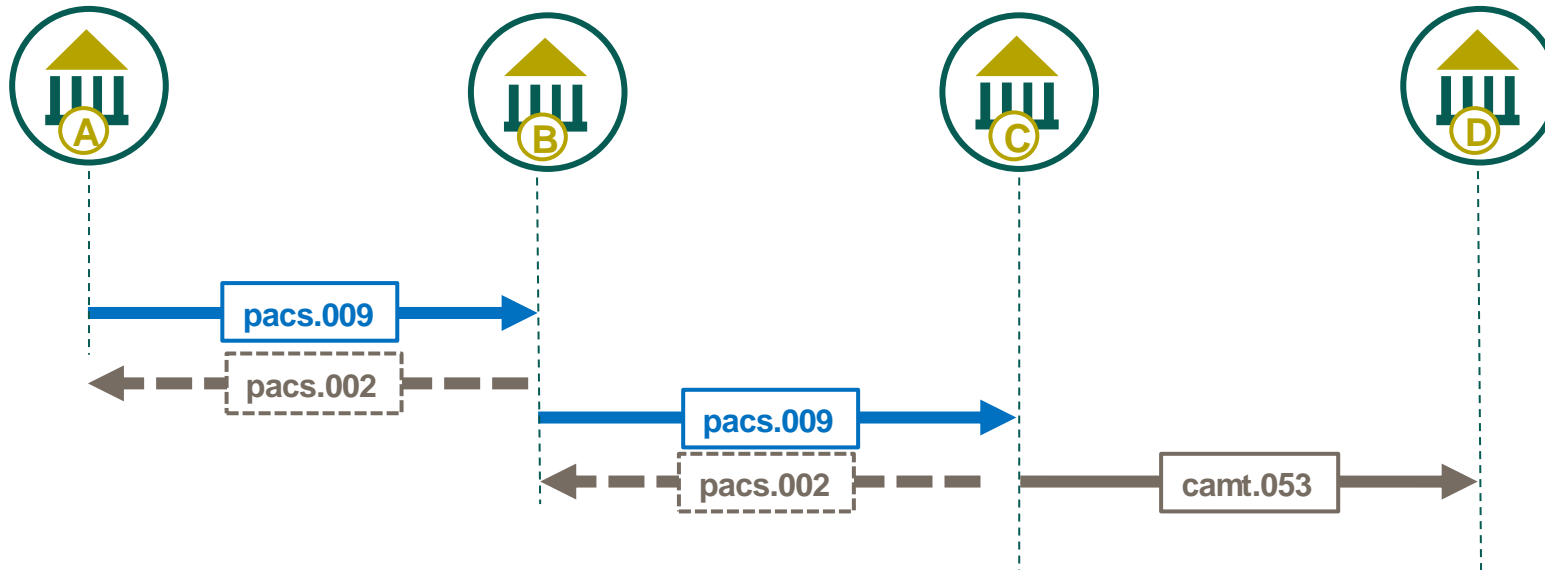

The Financial Institution Credit Transfer message is sent by a Debtor Financial Institution to a Creditor Financial Institution, directly or through other agents and/or a payment clearing and settlement system. It is used to move funds from a debtor account to a creditor, where both Debtor and Creditor are **Financial Institutions**.

High Level message flow demonstrating the change in party roles between messages

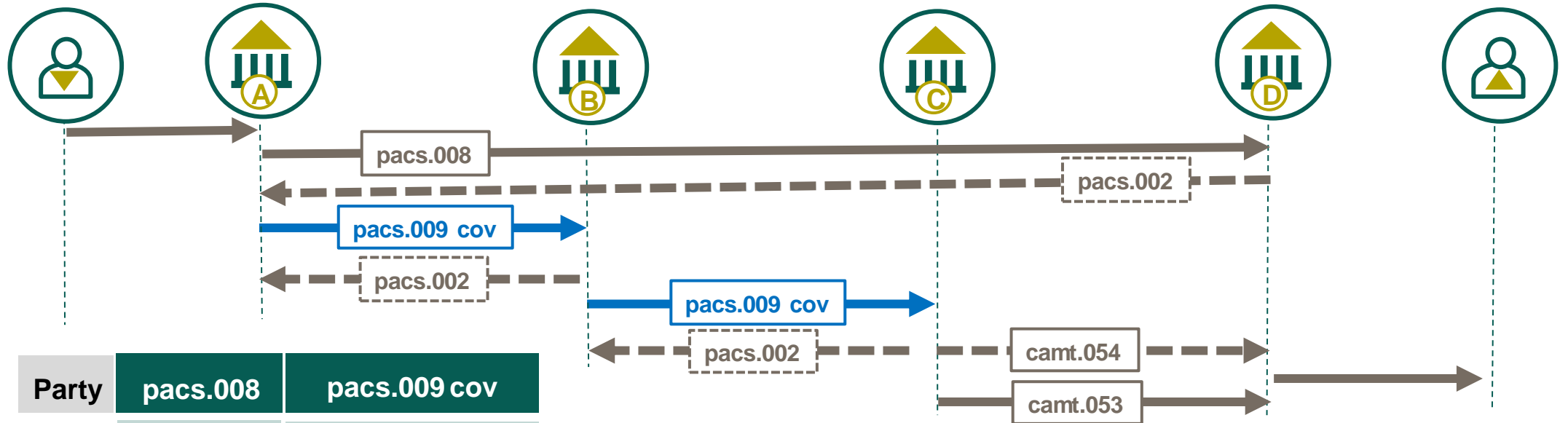

Party	pacs.008	pacs.009 cov
	Debtor	Underlying Debtor
	Debtor Agent	Debtor
	Creditor Agent	Creditor
	Creditor	Underlying Creditor

The Financial Institution Credit Transfer cover message is sent by a Debtor Financial Institution to a Creditor Financial Institution, directly or through other agents and/or a payment clearing and settlement system. It is important to recognise that some **roles change** between these parallel messages.

High Level Use Case demonstrating the change in party roles between messages

pac.s.009 cov

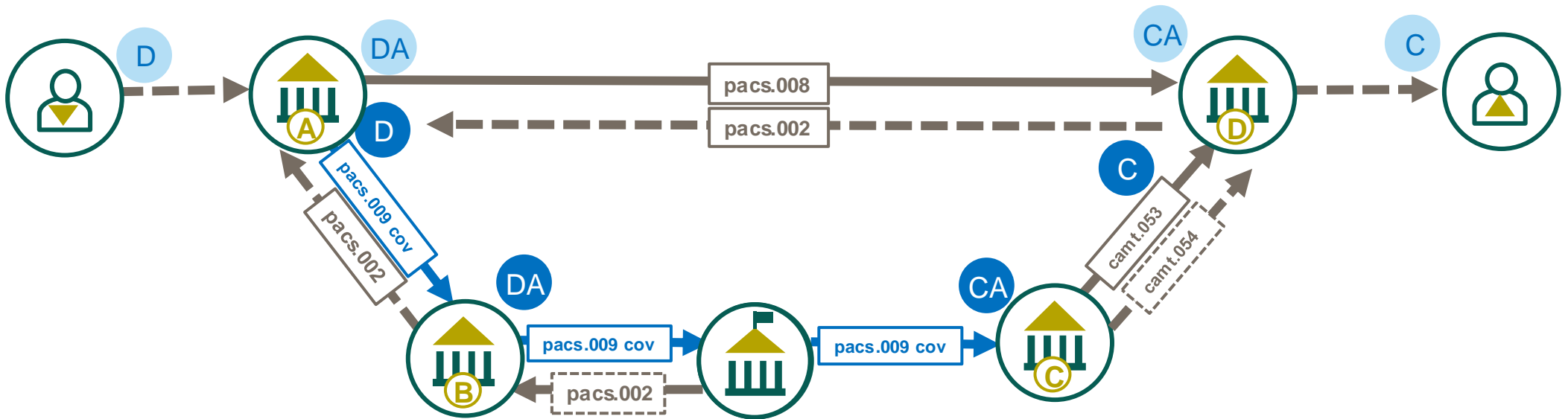

Party	pac.s.008	pac.s.009 cov
	Debtor D	Underlying Debtor D
	Debtor Agent DA	Debtor D
	Creditor Agent CA	Creditor C
	Creditor C	Underlying Creditor C

The correspondent banking cover payment method utilises both the pacs.008 and pacs.009 cov as a whole transaction, whereby the UETR element within these messages contain the **same** UETR which effectively interlink the messages. As an interlinked message it is important to understand the way certain parties change their role in the pacs.009 cov This is demonstrated in the example

Group Header



pac009 (COV) Financial Institution Credit Transfer - Message Identification

Min 1 – Max 1

Each ISO 20022 payment message has a **Message Identification** element, located in the Group Header. This **35 character** identifier is a point-to-point reference used to unambiguously identify the message.



For Payment Clearing and Settlement (pac009) messages the Message Identification has no exact equivalent in the legacy MT payment message. However, the MT 202 Sender's Reference (Field 20) could be considered a similar comparison where a pac009 message contains a single Transaction.



Each transaction's *Credit Transfer Transaction Information* contains a variety of nested *Payment Identification* elements to capture reference related to the individual transaction such as a UETR (Unique End-to-end Transaction Reference)

Group Header ➤ Message Identification

pac.009 (COV) Financial Institution Credit Transfer – Creation DateTime

Min 1 – Max 1

The pac.009 message **Creation Date** captures the date and time which the message was created.

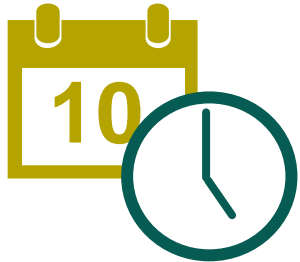

CBPR+ usage guidelines mandate the time zone that the time represents as an offset against Universal Time Coordinated (UTC):

Local time with UTC offset `YYYY-MM-DDThh:mm:ss.sss+/-hh:mm`

- For example: `2002-10-10T12:00:00-05:00` (noon/midday on 10 October 2002, Central Daylight Savings Time as well as Eastern Standard Time in the U.S.)



All CBPR+ time elements need offset against UTC. Milliseconds are optional.

Group Header ➤ Creation Date Time

pac.009 (COV) Financial Institution Credit Transfer - Number of Transactions

Min 1 – Max 1

The pac.009 message **Number of Transactions** captures the number of individual transaction contained within the message.



The number of transactions in CBPR+ payment usage guidelines is fixed to 1.



Single transactions in the CBPR+ payment usage guidelines enable a transaction to be managed and unlocks highly automated, frictionless, instant payments, supporting the next generation of innovation.

Group Header ▶ Number of Transactions

pac.009 (COV) Financial Institution Credit Transfer– Settlement Information

Min 1 – Max 1

The pac.009 **Settlement Method** element within the Group Header **Settlement Information**, includes one of the embedded codes to indicate how the payment message will be settled.

The **Settlement Method** element in the pac.009 allows a choice of an embedded code.



INDA indicate this Customer Credit Transfer will be settlement by the Instructed Agent (as the Account Servicing Institution) The account held at the Instructed Agent may captured in the dedicated **Settlement Account** element.

INGA indicate this Customer Credit Transfer has already been settlement by the Instructing Agent, who has credited the Account they service for the Instructed Agent (as an Account Owner). The account held by the Instructed Agent with the Instructing Agent may captured in the dedicated **Settlement Account** element.



Settlement Method code CLRG is not part of CBPR+ specifications but instead used in Market Infrastructure specification (HVPS+)

Group Header > Settlement Information > Settlement Method

pacs.009 (COV) FI to FI Customer Credit Transfer – Settlement Account

The pacs.009 message **Settlement Account** is a nested element as part of **Settlement Information**, this element identifies information related to an account used to settle the payment instruction.

Min 0 – Max 1

The **Settlement Account** identifies the account details maintained at the account servicing institution (Agent responsible for the settlement of the instruction as indicated in the **Settlement Method**)



Min 1 – Max 1 Identification identifies the account maintained at the Debtor Agent (Account Servicing Institution)

Min 0 – Max 1 Type uses the external Cash Account Type code list to identify the type of account

Min 0 – Max 1 Currency identifies the currency if the account

Min 0 – Max 1 Name identifies the name of the account as assigned by the Account Servicing Institution

Min 0 – Max 1 Proxy captures an alternative identification of the account number such as an email address. This element has further nested **Type** which is a choice of external code list or proprietary code and **Identification** which are both mandatory where the Proxy element is used.

Credit Transfer Transaction Information



pacs.009 (COV) Financial Institution Credit Transfer - Payment Identification

Min 1 – Max 1

The pacs message **Payment Identification** provides a set of elements to identify the payment, of which several are mandatory elements

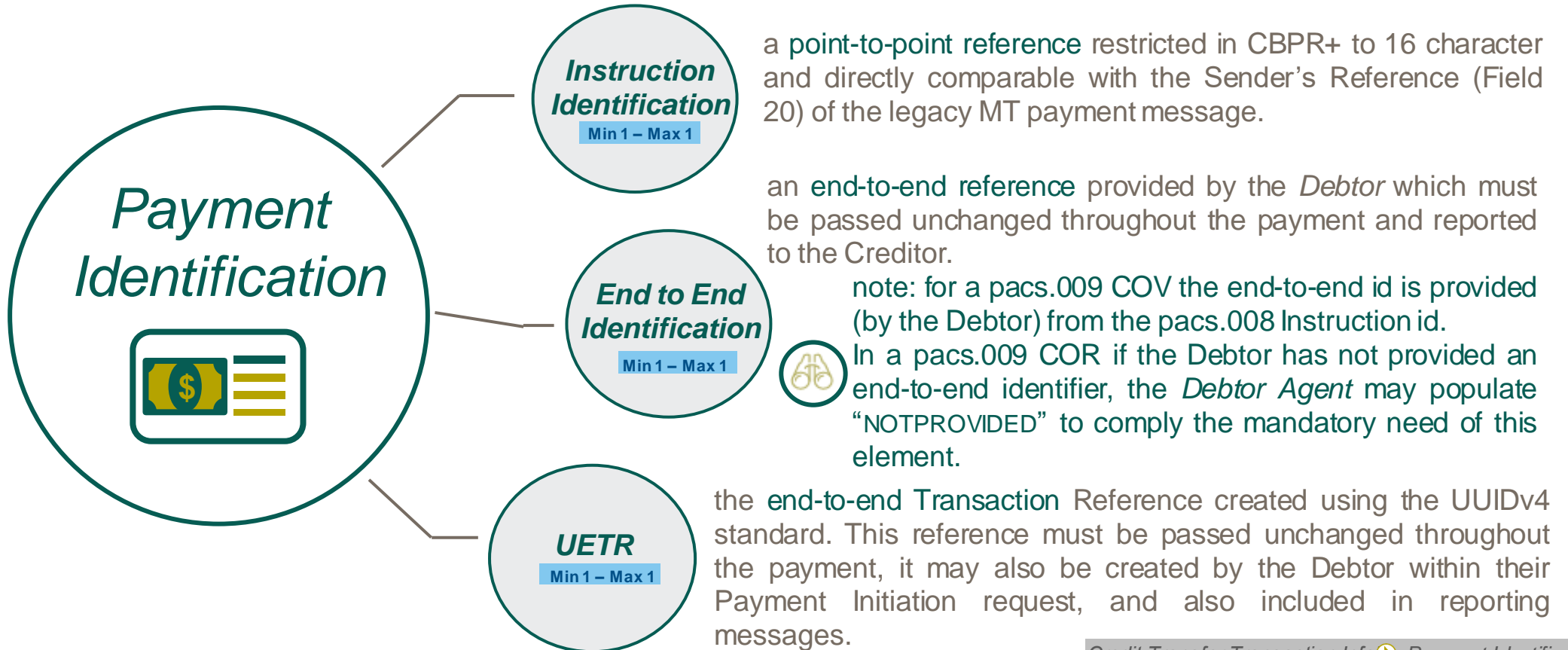

pac009 (COV) Financial Institution Credit Transfer - Payment Identification (continued)

Min 1 – Max 1

The pac0 message **Payment Identification** also provides a set of optional elements to identify the payment.

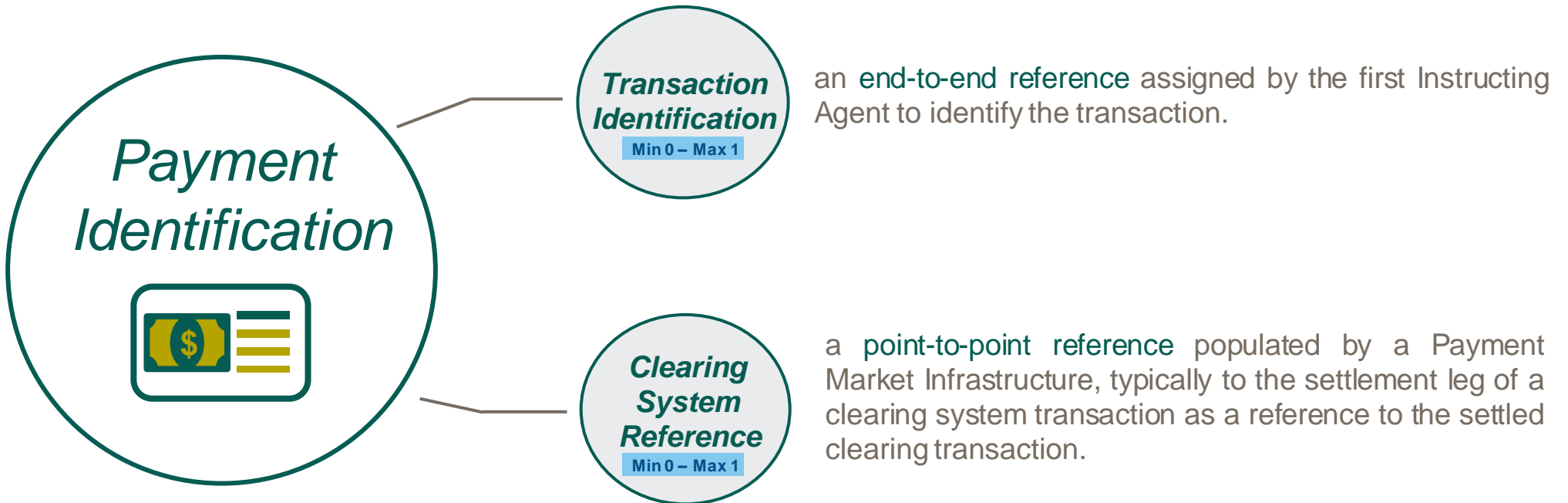

pacs.009 (COV) Financial Institution Credit Transfer - Payment Type Information

Min 0 – Max 1

The pacs message **Payment Type Information** provides a set of optional elements where the payment type can be described.

a choice of imbedded codes representing the urgency considered by the Instructing Agent, this point-to-point information may be used by the Instructed Agent to differentiate the processing priority.

Instruction Priority

Min 0 – Max 1

a choice of imbedded codes representing the clearing channel to be used to process the payment. e.g., RTGS

Clearing Channel

Min 0 – Max 1

Payment Type Information



Service Level

Min 0 – Max 3

A nested element which may either use an external ISO Service Level code or a proprietary code. It is used to identify a particular agreed service level which should be applied to the payment.

For example, code G001 can be used to identify a gpi Tracked Cover Transfer similarly to Field 111 value 001 in the MT 202 COV

Local Instrument

Min 0 – Max 1

A nested element which may either use an external ISO Local Instrument code or a proprietary code. It is used to identify the type of payment local instrument such as a Standing Order.



Note: the ISO instrument codes are registered by specific community group (captured in the code list)

Category Purpose

Min 0 – Max 1

A nested element which may either use an external ISO Category Purpose code or a proprietary code. It is used to identify the category of payment. For example, SECU Transaction is the payment of securities.



pacs.009 (COV) Financial Institution Credit Transfer– Interbank Settlement Amount and Date

The pacs.009 message (unlike the pacs.008) has only one element to capture the amount of the Credit Transfer, **Interbank Settlement Amount**.

Min 1 – Max 1



Interbank Settlement Amount

A mandated currency amount moved between the *Instructing Agent* and the *Instructed Agent*. This therefore is the point-to-point currency amount exchanged, comparable with the MT Field 32A

Interbank Settlement Date

Min 1 – Max 1

A mandated date on which the *Interbank Settlement* should be executed between the *Instructing Agent* and the *Instructed Agent*. This therefore is the **value date** comparable with the MT Field 32A



Note: the Financial Institution Credit Transfer (pacs.009) has no *Instructed Amount* element, *Exchange Rate* or *Charger Bearer* (unlike the pacs.008) as the Instructed Settlement Amount is expected to be transferred across the end-to-end payment chain without any charges being applied or currency conversions.



pac.009 (COV) Financial Institution Credit Transfer – Settlement Priority, Time Indication & Request

The pac.009 message has three optional elements to capture the optional information related to the settlement of the instructions.

Min 0 – Max 1



The **Settlement Priority** provides an optional choice of embedded codes to indicate the instruction's settlement priority from the perspective of the Instructing Agent. This point-to-point information may be used by the Instructed Agent to identify the priority associated with the **Settlement Method** and should not be confused with the **Instruction Priority**.



Note: Where the **Settlement Method** of the pac.009 is 'INDA' (settled performed by the Instructed Agent) this indicates the Settlement Priority. Code 'INGA' implies settlement has already occurred for this point-to-point payment and therefore the Settlement Priority is not necessary.

Min 0 – Max 1



The **Settlement Time Indication** optionally captures the time settlement occurred at a transaction administrator such as a Market Infrastructure.

This DateTime can be captured in two nested elements, **Debit Date Time** and **Credit Date Time**.

Min 0 – Max 1



The **Settlement Time Request** optionally captures the time settlement is requested for the payment instruction by the Instructing Agent. This Time can be capture in four nested elements:

- **CLS Time** the time the amount must be credit to CLS Bank
- **Till Time** the time until which the payment may be settled
- **From Time** the time from which the payment may be settled
- **Reject Time** the time from which the payment must be settled (to avoid reject)

Credit Transfer Transaction Information

pac.009 (COV) Financial Institution Credit Transfer - Instructed and Instructing Agents

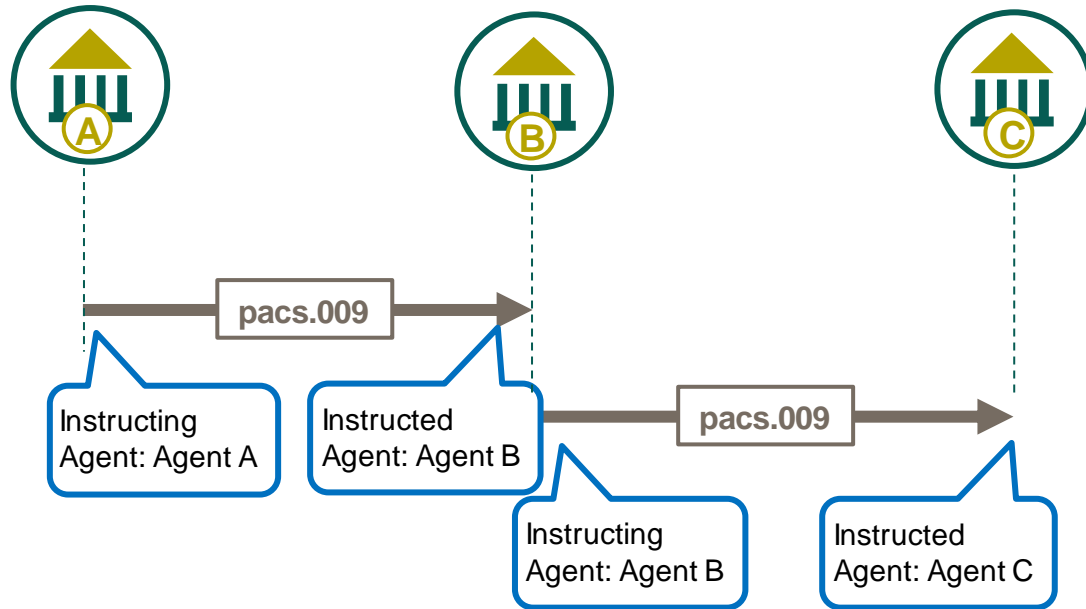

Instructing Agent and **Instructed Agent** represent the Agents involved in the pac.009 point-to-point message exchange. These roles therefore change on each payment leg.



Instructing Agent and *Instructed Agent* elements are required in all pac.009 messages and are only available in the **Credit Transfer Information**

Credit Transfer Transaction Information

Instructing Agent

Instructed Agent



pacs.009 (COV) Financial Institution Credit Transfer – Previous Instructing Agents

The pacs message can capture up to 3 Previous Instructing Agents, which represent an Agent who previously only played a dynamic role in the payment between the Debtor Agent and Creditor Agent.

Min 0 – Max 1

The **Previous Instructing Agent 1** captures the first historic Agent between the Debtor Agent and the Previous Instructing Agent 2 (where present) and the Instructing Agent. This optional element is comparable with the Field 72 first /INS/ occurrence in the legacy FIN message.



Min 0 – Max 1

The **Previous Instructing Agent 1 Account** captured the account related between this Agent and Previous Instructing Agent 2 (where present) or the Instructing Agent. This optional element has not comparable field in the legacy FIN message

Min 0 – Max 1

The **Previous Instructing Agent 2** captures the second Previous Instructing Agent between the Previous Instructing Agent 1 and the Previous Instructing Agent 3 (where present) and the Instructing Agent. This optional element is comparable with the Field 72 second /INS/ occurrence in the legacy FIN message.



Min 0 – Max 1

The **Previous Instructing Agent 2 Account** captured the account related between this Agent and Previous Instructing Agent 2 (where present) or the Instructing Agent. This optional element has not comparable field in the legacy FIN message.

Min 0 – Max 1

The **Previous Instructing Agent 3** captures the third Previous Instructing Agent between the Agent and the Instructing Agent. This optional element is comparable with the Field 72 third /INS/ occurrence in the legacy FIN message.



Min 0 – Max 1

The **Previous Instructing Agent 3 Account** captured the account related between this Agent and Previous Instructing Agent 2 (where present) or the Instructing Agent. This optional element has not comparable field in the legacy FIN message



Debtor Agent and Creditor Agent elements must be present before the previous **Instructing Agent 1** element can be used

pacs.009 (COV) Financial Institution Credit Transfer– Previous Instructing Agents versus Intermediary Agents

The ISO 20022 pacs messages have a number of optional Agent elements whose roles change throughout the life cycle of the payment. **Intermediary Agent** is an example of this, where these agents are classified in numeric order (i.e., *Intermediary Agent 1*) **Previous Instructing Agent** however is a static role which allows additional Previous Instructing Agent to be appended to the history of the payment.

The below diagram visualizes the change of Agent role at different stages of the payment transaction life cycle.

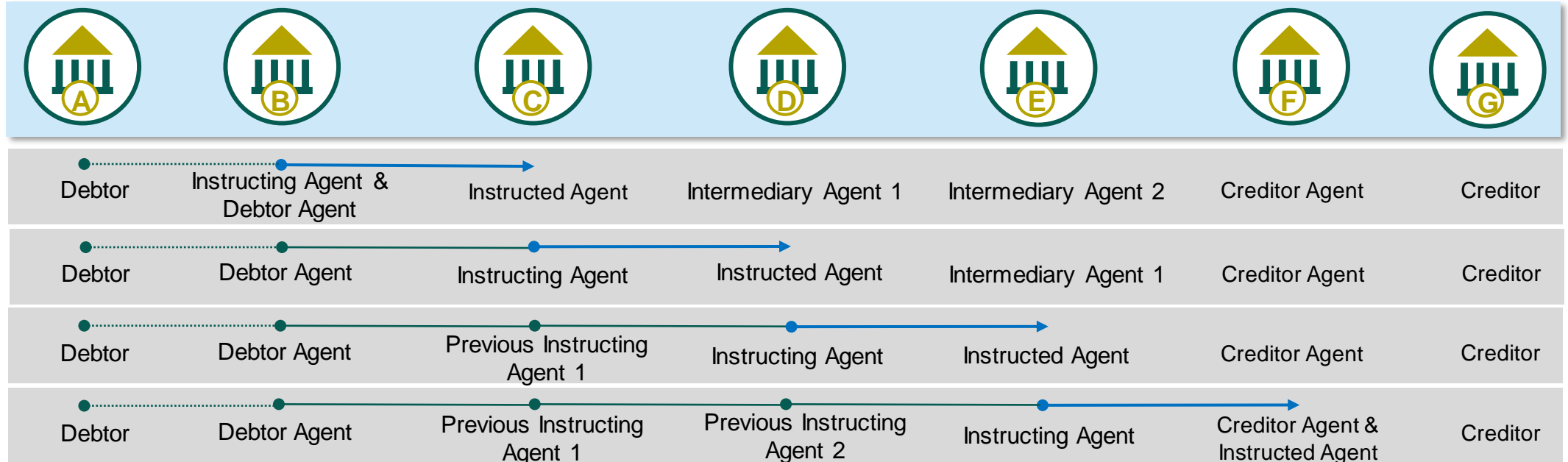

Note: the static roles of Previous Instructing Agent transition into Intermediary Agents in the potential return chain (refer to the pacs.004 section for Payment Returns)

pacs.009 (COV) Financial Institution Credit Transfer – Intermediary Agents

The pacs message can capture up to 3 Intermediary Agents, which play a dynamic role in the payment between the Debtor Agent and Creditor Agent.

Min 0 – Max 1

The **Intermediary Agent 1** captures the first Intermediary Agent between the Debtor Agent and Creditor Agent for who the Instructed Agent attempt to instruct the payment on to. This optional element is comparable with the Field 56a in the legacy FIN message.



Min 0 – Max 1

The **Intermediary Agent 1 Account** captured the account related to this Intermediary Agent, with the Instructed Agent. This element can be compared to the Party Identifier of the legacy Field 56a.

Min 0 – Max 1

The **Intermediary Agent 2** captures the second Intermediary Agent between the Intermediary Agent 1 and the Creditor Agent. This optional element has not comparable field in the legacy FIN message.



Min 0 – Max 1

The **Intermediary Agent 2 Account** captured the account related to this Intermediary Agent, with the Intermediary Agent 1. This optional element has not comparable field in the legacy FIN message.

Min 0 – Max 1

The **Intermediary Agent 3** captures the third Intermediary Agent between the Intermediary Agent 2 and the Creditor Agent. This optional element has not comparable field in the legacy FIN message.



Min 0 – Max 1

The **Intermediary Agent 3 Account** captured the account related to this Intermediary Agent, with the Intermediary Agent 2. This optional element has not comparable field in the legacy FIN message.



Debtor Agent and Creditor Agent elements must be present before the **Intermediary Agent 1** element can be used

pacs.009 (COV) Financial Institution Credit Transfer– Debtor

The ISO 2022 pacs messages describe the Agent whose account is debited for a transaction as the **Debtor**. The *Debtor* sub elements describe the *Debtor* in greater detail.

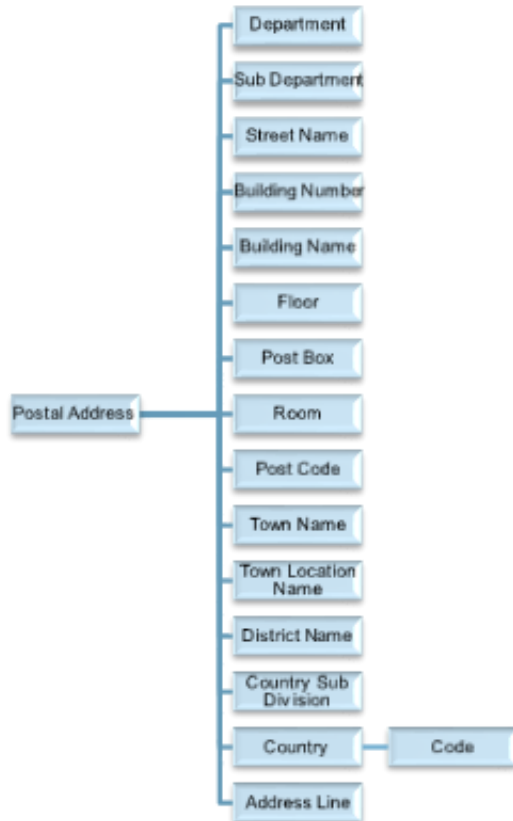

Information used to identify a Debtor by a clearing system identifier.

The BIC which identifies the *Debtor*

Legal entity identifier of the financial institution.

Name by which the Agent is known

Nested element capturing either structured or unstructured *Debtor* address details

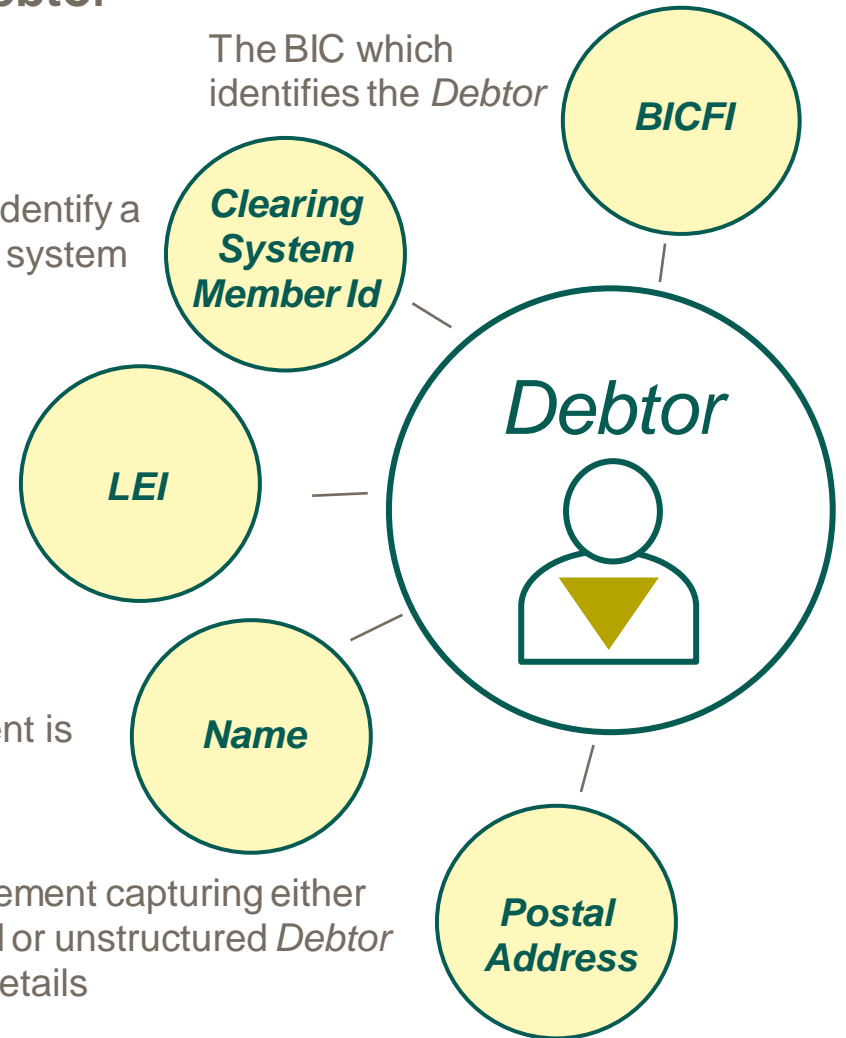

pac.009 (COV) Financial Institution Credit Transfer – Debtor Account

Min 0 – Max 1

The pac.009 **Debtor Account** is used to capture the account information for which debit entry is/has been applied to the Debtor's account, which are also reflected in their account Statement.

The **Debtor Account** uses a variety of nested elements to capture information related to the account.



Min 1 – Max 1 Identification identifies the account maintained at the Debtor Agent (Account Servicing Institution)

Min 0 – Max 1 Type uses the external Cash Account Type code list to identify the type of account

Min 0 – Max 1 Currency identifies the currency of the account

Min 0 – Max 1 Name identifies the name of the account as assigned by the Debtor Agent (Account Servicing Institution)

Min 0 – Max 1 Proxy captures an alternative identification of the account number such as an email address. This element has further nested **Type** which is a choice of external code list or proprietary code and **Identification** which are both mandatory where the Proxy element is used.



the pac.009 the Debtor is a Financial Institution, therefore the nested elements **Name** and **Proxy** are unlikely to be used.



pac.009 (COV) Financial Institution Credit Transfer– Debtor Agent and Creditor Agent

Min 0 – Max 1

Min 0 – Max 1

The **Debtor Agent** and **Creditor Agent** are static roles in the pac.009 FI to FI Customer Credit Transfer. These agents maintain a relationship with their customers; the **Debtor** and **Creditor**. However, unlike the pac.008 Debtor Agent and Creditor Agent, which are optional, which cover the scenario where the Debtor and Creditor (as Financial Institutions) maintain a direct Nostro/Vostro account relationship.



Note: Where the **Debtor** and **Creditor** maintain a relationship with the same intermediary counterpart. It is recommended that this Agent is captured in the **Creditor Agent** element to align with translation from the legacy MT message.

Credit Transfer Transaction Information 

 Debtor Agent

 Creditor Agent

pac.009 (COV) Financial Institution Credit Transfer – Debtor Agent Account and Creditor Agent Account

Min 0 – Max 1

The pac.009 **Debtor Agent Account** and **Creditor Agent Account** is used to capture the account information related to these Agents. The nature of this element implies there is an Agent or Agent in between the Debtor Agent and Creditor Agent in the payment transaction.

The **Debtor Agent Account** and **Creditor Agent Account** uses a variety of nested elements to capture information related to the account.



Min 1 – Max 1

Identification identifies the account maintained at the Creditor Agent (Account Servicing Institution)

Min 0 – Max 1

Type uses the external Cash Account Type code list to identify the type of account

Min 0 – Max 1

Currency identifies the currency of the account

Min 0 – Max 1

Name identifies the name of the account as assigned by the Creditor Agent (Account Servicing Institution)

Min 0 – Max 1

Proxy captures an alternative identification of the account number such as an email address. This element has further nested **Type** which is a choice of external code list or proprietary code and **Identification** which are both mandatory where the Proxy element is used.



Debtor Agent and Creditor Agent are Financial Institutions, therefore the nested elements **Name** and **Proxy** are unlikely to be used.



pac.009 (COV) Financial Institution Credit Transfer– Creditor

The ISO 2022 pac messages describe the Agent whose account is credited for a transaction as the **Creditor**. The *Creditor* sub elements describe the *Creditor* in greater detail.

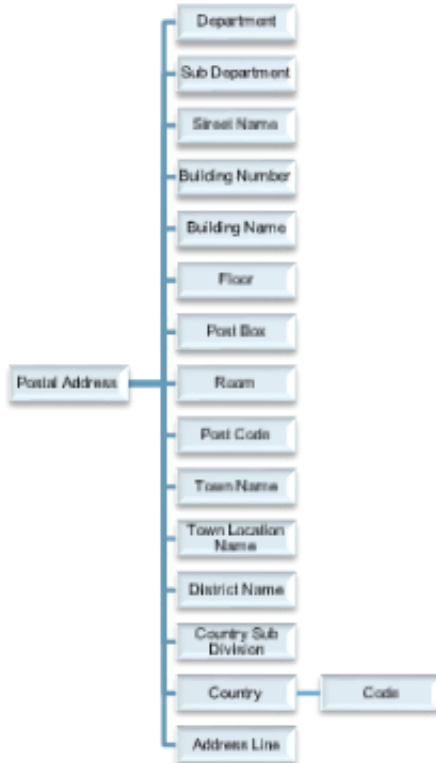

Information used to identify a Debtor by a clearing system identifier.

Legal entity identifier of the financial institution.

Name by which the Agent is known

Nested element capturing either structured or unstructured *Debtor* address details

The BIC which identifies the *Creditor*

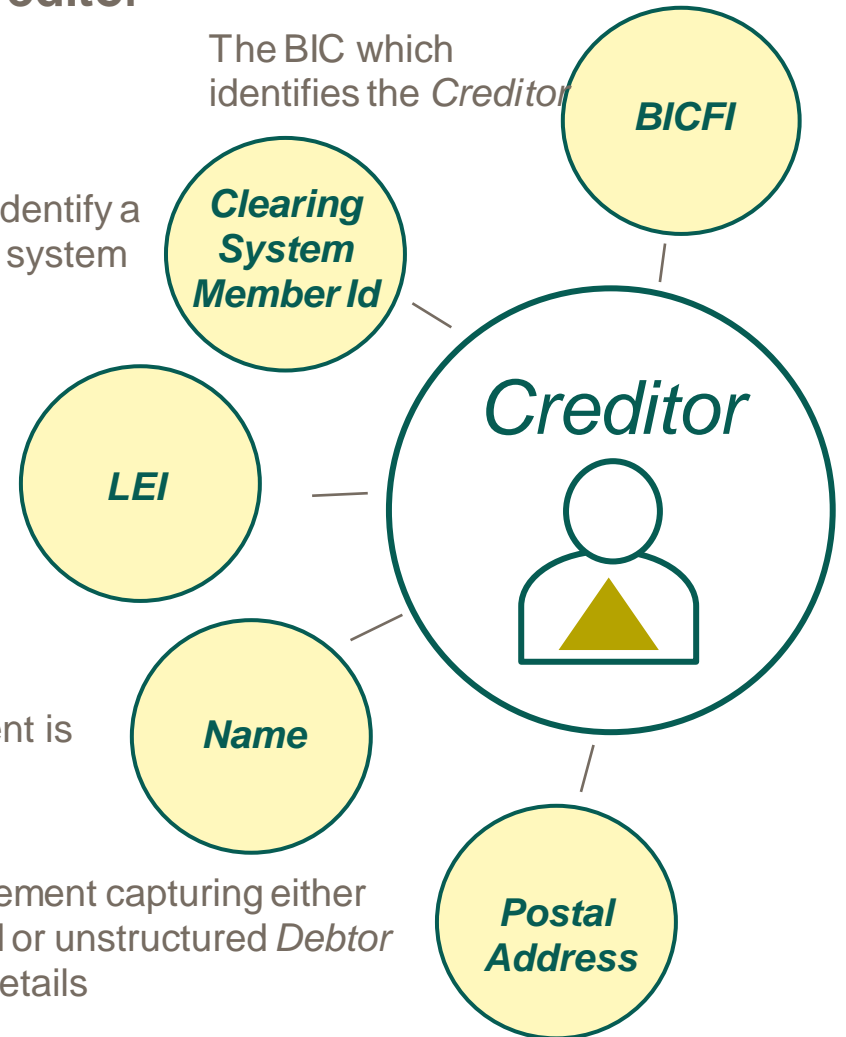

Certain legacy MT messages, such as the MT200, identify the Creditor from the message sender, whereas this party would need to be repeated in the pac.009

pac.009 (COV) Financial Institution Credit Transfer – Creditor Account

Min 0 – Max 1

The pac.009 **Creditor Account** is used to capture the account information for which a credit entry is intended to be applied to the Creditor's account, which are also reflected in their account Statement.

The **Creditor Account** uses a variety of nested elements to capture information related to the account.



Min 1 – Max 1 Identification identifies the account maintained at the Creditor Agent (Account Servicing Institution)

Min 0 – Max 1 Type uses the external Cash Account Type code list to identify the type of account

Min 0 – Max 1 Currency identifies the currency of the account

Min 0 – Max 1 Name identifies the name of the account as assigned by the Creditor Agent (Account Servicing Institution)

Min 0 – Max 1 Proxy captures an alternative identification of the account number such as an email address. This element has further nested **Type** which is a choice of external code list or proprietary code and **Identification** which are both mandatory where the Proxy element is used.



the pac.009 the Creditor is a Financial Institution, therefore the nested elements **Name** and **Proxy** are unlikely to be used.



pacs.009 (COV) Financial Institution Credit Transfer– Instruction For elements

The **Instruction for Next Agent** and **Instruction for Creditor Agent** elements within the pacs.009 Financial Institution Credit Transfer optionally provides information related to the processing of the payment for these Agents.



Min 0 – Max 2

The **Instruction for Creditor Agent** element offers a multiplicity of up to 2 occurrences of information. This element enables:

- the use of 2 embedded **codes** to describe the instruction
- free format *instruction information*
- or both, where the free format complements the code.

The use of this element may be **bilaterally** agreed with the *Creditor Agent*. It must be passed on throughout the life cycle of the transaction until the payment reaches the *Credit Agent*.



Min 0 – Max 6

The **Instruction for Next Agent** element offers a multiplicity of up to 6 occurrences of information. This element is restricted to free format *instruction information* in CBPR+. The element is used to provide instruction to the next Agent (which may not be the Creditor Agent)

Credit Transfer Transaction Information

Instruction for Creditor Agent

Instruction for Next Agent

pac.009 (COV) Financial Institution Credit Transfer – Purpose

Min 0 – Max 1

The **Purpose** elements within the pac.009 Financial Institution Credit Transfer capture the reason for the payment transaction which may either use an external ISO **Purpose code** or a proprietary code.

The purpose is used by the capture the nature of the payment e.g. **CORT** Trade Settlement Payment, **CFEE** Cancellation Fees etc. and should not be confused with Regulatory Reporting codes present in the pac.008.



The externalised Purpose code set is classified by the purpose, for example commercial, for which the numerous codes within the classification are each described by Name and Definition.

For example:

OTCD is classified within the Collateral categorisation, with the *Name* **OTC Derivatives** described as a **Cash collateral related to over-the-counter (OTC) Derivatives** - in general for example contracts which are traded and privately negotiated.



Category Purpose also captures a high level purpose, which unlike *Purpose* is less granular but can trigger special processing e.g. Category Purpose code **SECU** ‘Securities’ may trigger **pac.002 Payment Status Report** to provide update on the progress of the payment to the previous Agent.

Credit Transfer Transaction Information 

 Purpose

pacs.009 (COV) Financial Institution Credit Transfer – Remittance Information

The optional **Remittance Information** element within the pacs.009 COV Financial Institution Credit Transfer is nested to provide **Unstructured** information related to payment.

Min 0 – Max 1

Remittance Information enable the matching/reconciliation of an entry that the payment is intended to settle.



Min 0 – Max 1

The **Unstructured** sub element captures free format *Remittance Information* which is restricted in CBPR+ to 140 characters to ensure backward compatibility with the legacy MT message during coexistence.



Note: the pacs.008 **Remittance Information** is captured in the pacs.009 COV within the **Underlying Customer Credit Transfer, Remittance Information** element. The **Remittance Information** in the pacs.009 COV is for **Creditor** this message (often the Creditor Agent of the pacs.008) As this information is not present in the pacs.008 it is unlikely the pacs.009 COV remittance information will be used.

Credit Transfer Transaction Info  Remittance Information 

Unstructured

Pacs.009 (COV) Financial Institution Credit Transfer – Underlying Customer Credit Transfer

The **Underlying Customer Credit Transfer** element is used when the pacs.009 *Financial Institution Credit Transfer* message is being utilized to cover a pacs.008 *FI to FI Customer Credit Transfer*. The information contained within this nested element relates directly to the information exchanged between the Instructing Agent and Instructed Agent of the pacs.008 FI to FI Customer Credit Transfer and can be compared with Sequence B of the legacy MT 202 COV.

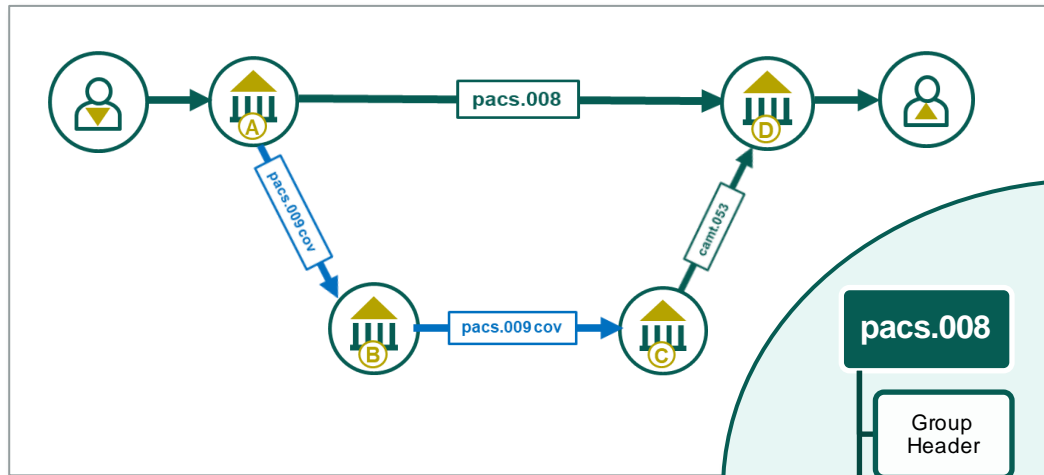

When utilizing the **Underlying Customer Credit Transfer** nested element as part of a pacs.009 *Financial Institution Credit Transfer* cover message the:

- **Debtor** Min 1 – Max 1
 - **Debtor Agent** Min 1 – Max 1
 - **Creditor Agent** Min 1 – Max 1
 - **Creditor** Min 1 – Max 1
- are all mandatory elements.

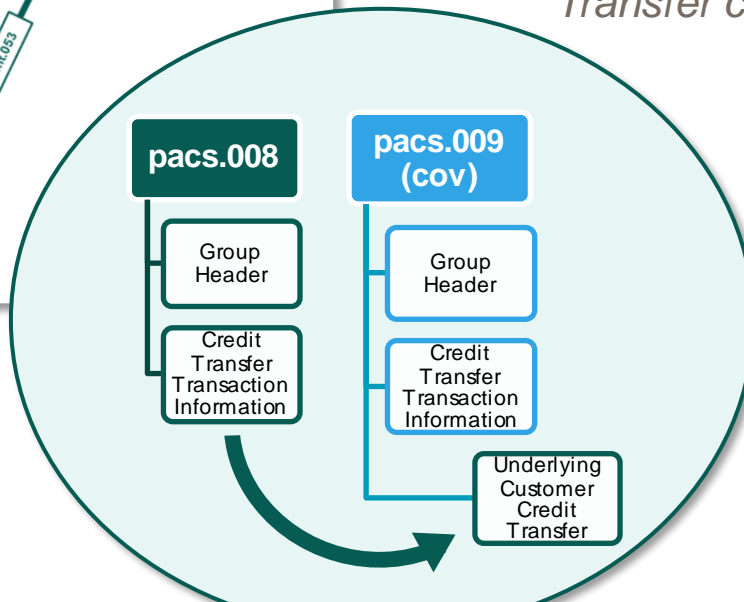

Note: **Instruction for Creditor Agent** from the Underlying Customer Credit Transfer does not need to be included



Credit Transfer Transaction Information ✓

➤ Underlying Customer Credit Transfer

Index of pacs.009 (COV) Use Cases

Use case should be considered as a principal example whereby use case may be cross referenced e.g. a use case involving a Market Infrastructure can apply the Market Infrastructure legs to other use cases.

Cover Method Financial Institution Payments

Use Case p.9.2.1 - High Level Customer Credit Transfer (pacs.008) settled using the cover method (pacs.009 COV)

Use Case p.9.2.2 - High Level Customer Credit Transfer (pacs.008) settled using the cover method (pacs.009 COV) over a Payment Market Infrastructure

Use Case p.9.2.3 - High Level Customer Credit Transfer (pacs.008) settled using the cover method (pacs.009 COV) where an incorrect intermediary is used

Use Case p.9.2.4 – High Level FI to FI Customer Credit Transfer involved a serial leg into a cover method (pacs.009 COV)

Use Case p.9.2.5 – High Level FI to FI Customer Credit Transfer involved a serial leg in and out of a cover method (pacs.009 COV)

Use Case p.9.2.6 - High Level FI to FI Customer Credit Transfer involved a serial leg out of a cover method (pacs.009 COV)

High Level Customer Credit Transfer (pacs.008) settled using the cover method (pacs.009 COV)

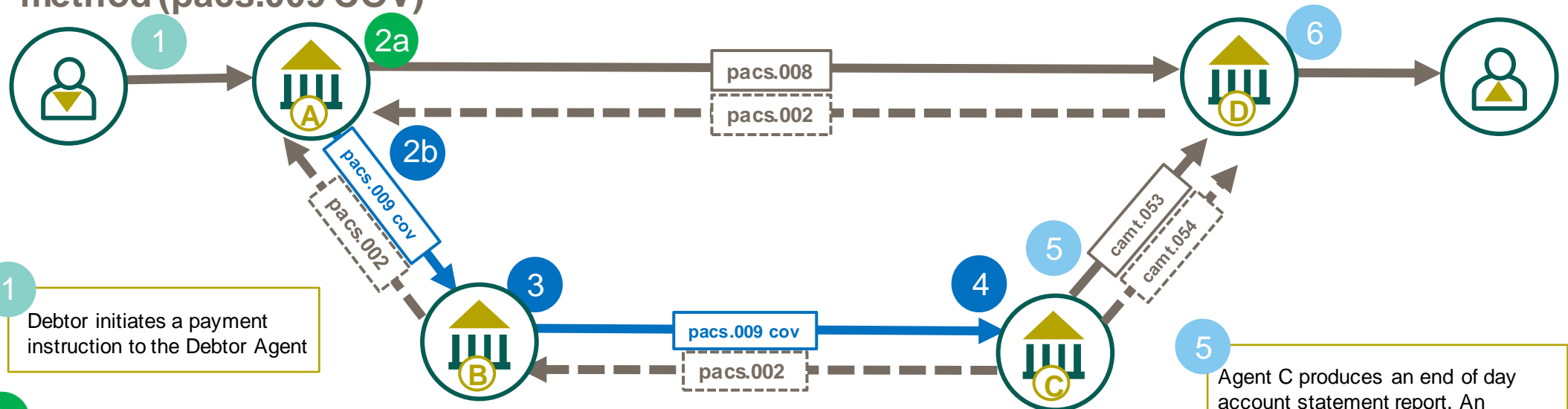

1 Debtor initiates a payment instruction to the Debtor Agent

2a Debtor Agent (A) initiates a payment using the cover method to the Creditor Agent (D)

2b In parallel the Debtor Agent (A) initiates a covering payment to credit the account of Agent (D) who become the Creditor of the cover payment (pacs.009 cov). Agent A's role also changes in the cover payment where it becomes the Debtor, whereby Agent A's account with their correspondent (Agent B) is debited.

3 Agent B processes the payment on to Agent C

4 Agent C receives the payment and credits the account of Agent D as the Creditor

5 Agent C produces an end of day account statement report. An optional real time notifications e.g. advice of credit may have also been created at the time of the credit posting

6 Agent D reconciles the covering funds and credits the account of the Creditor, and may optionally provide a notification e.g. credit notification.



High Level FI Customer Credit Transfer (pacs.008) settled using the cover method (pacs.009 COV) over a Payment Market Infrastructure

Use Case p.9.2.2

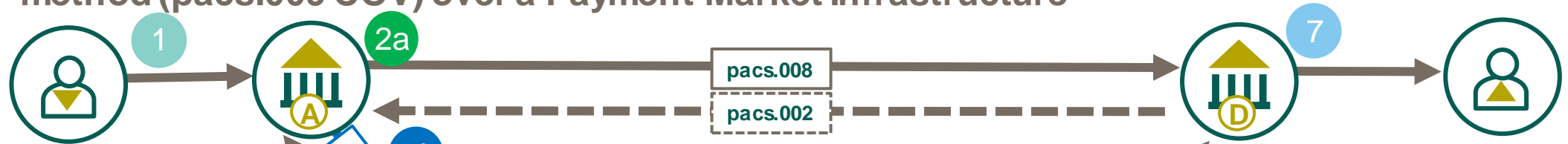

1
Debtor initiates a payment instruction to the Debtor Agent

2a
Debtor Agent (A) initiates a payment using the cover method to the Creditor Agent (D)

2b
In parallel the Debtor Agent (A) initiates a covering payment to credit the account of Agent (D) with their correspondent (Agent C)

3
Agent B processes the payment on Agent C, via the Payment Market Infrastructure.

Settlement Complete

4
Payment Market Infrastructure, settles the payment between Agent B and Agent C as direct participants of the Market Infrastructure, and provides a settlement confirmation to Agent B

5
Agent C receives the payment and credits the account of Agent D

6
Agent C produces an end of day account statement report. An optional real time notifications e.g. advice of credit may have also been created at the time of the credit posting

7
Agent D reconciles the covering funds and credits the account of the Creditor, and may optionally provide a notification e.g. credit notification.



Market Infrastructure will either conform to HVPS+ guidelines or establish their own usage guidelines based on the ISO 20022 standard. 342

High Level Customer Credit Transfer (pacs.008) settled using the cover method (pacs.009 COV) where an incorrect intermediary is used.

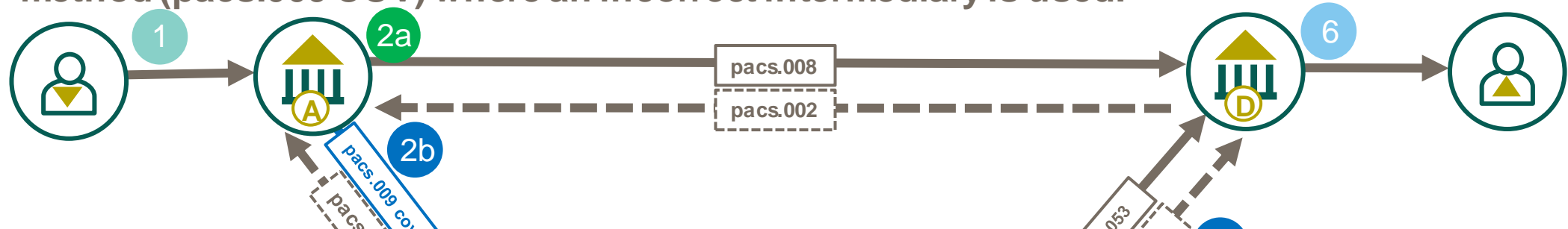

1 Debtor initiates a payment instruction to the Debtor Agent

2a Debtor Agent (A) initiates a payment using the cover method to the Creditor Agent (D)

2b In parallel the Debtor Agent (A) initiates a covering payment to credit the account of Agent (D) who become the Creditor of the cover payment (pacs.009 cov). Agent A's role also changes in the cover payment where it becomes the Debtor, whereby Agent A's account with their correspondent (Agent B) is debited.

3 Agent B processes the payment on to Agent Z

! Agent Z receives the payment and recognises they do not hold the account of Agent D as the Creditor. Agent Z reject the cover payment (pacs.009 cov) using a pacs.002 include the reject reason code

4 Recognising the error Agent B re-processes the payment on to Agent C using the same UETR (correcting the error in step 3)

5 Agent C receives the payment and credits the account of Agent D. Agent C produces an end of day account statement report. An optional real time notifications e.g. advice of credit may have also been created at the time of the credit posting

6 Agent D reconciles the covering funds and credits the account of the Creditor, and may optionally provide a notification e.g. credit notification.



High Level FI to FI Customer Credit Transfer involved a serial leg into a cover method (pacs.009 COV)

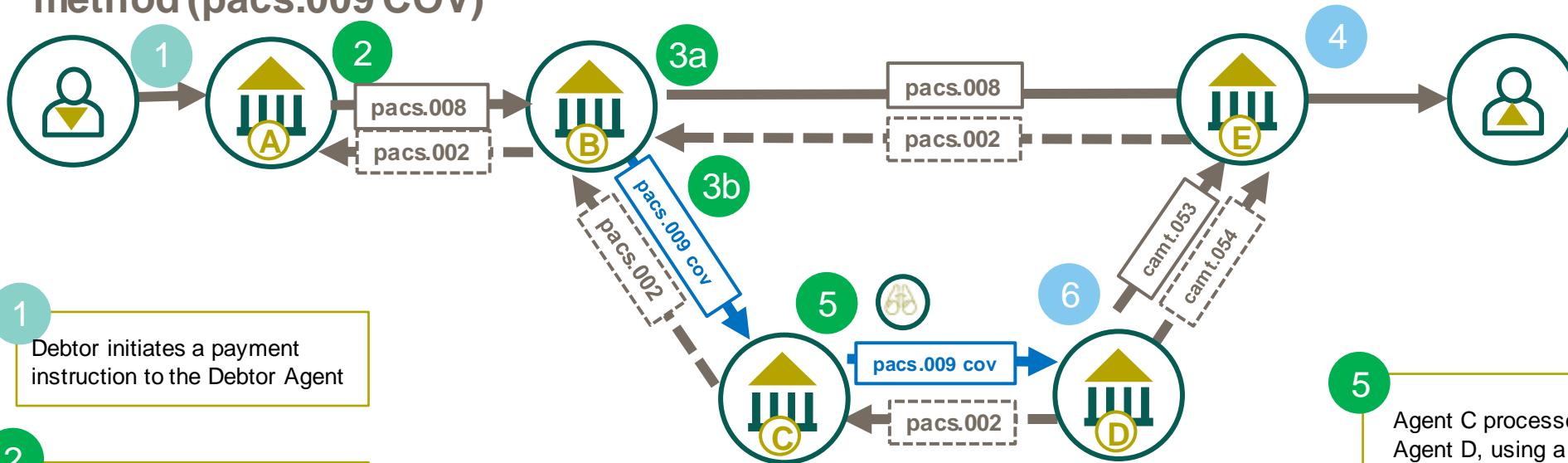

1 Debtor initiates a payment instruction to the Debtor Agent

2 Debtor Agent (A) initiates a payment using the serial method towards the Creditor Agent (E)

3a Agent B initiates a payment using the cover method towards the Creditor Agent (E) by sending a direct pacs.008 to Agent E who they have business relationship with.

3b In parallel the Agent (B) initiates a covering payment to credit the account of Agent (E) with their correspondent (Agent D)

4 Agent E receives the payment instruction and credits the account of the Creditor, and may optionally provide a notification e.g. credit notification. Alternatively, they may have chosen to await until settlement occurred in Step 6 based upon their risk appetite.

5 Agent C processes the payment on Agent D, using a correspondent banking business relationship

6 Agent D receives the payment and credits the account of Agent E. Agent D produces an end of day account statement report. An optional real time notification e.g. advice of credit may have also been created at the time of the credit posting



Note settlement of step 5 could alternative occur between Agent C and D using a Market Infrastructure..

High Level FI to FI Customer Credit Transfer involved a serial leg in and out of a cover method (pacs.009 COV)

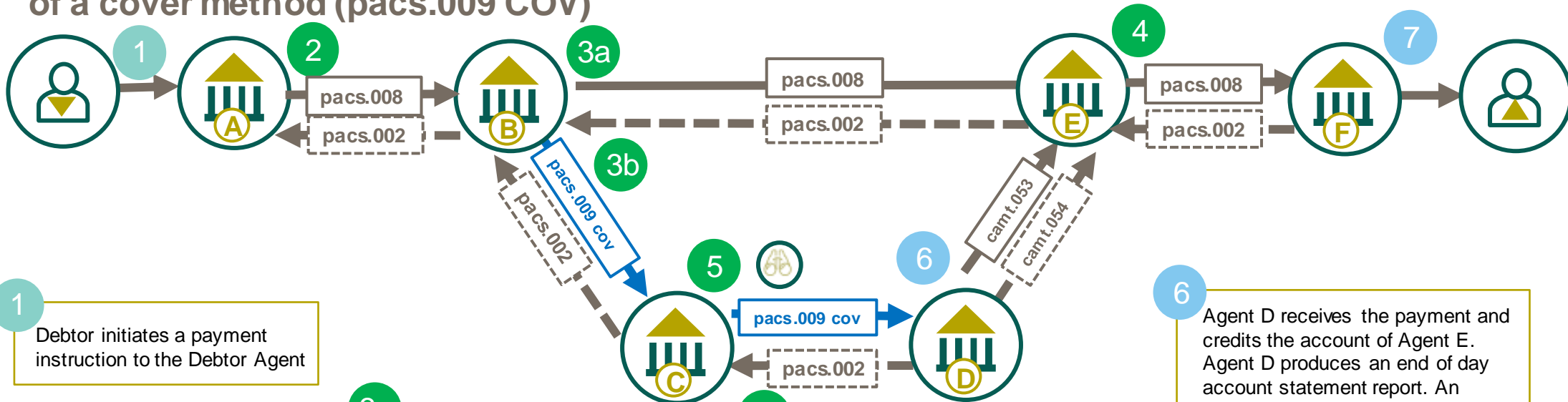

1 Debtor initiates a payment instruction to the Debtor Agent

2 Debtor Agent (A) initiates a payment using the serial method towards the Creditor Agent (F)

3a Agent B initiates a payment using the cover method towards the Creditor Agent (F) by sending a direct pacs.008 to Agent E who they have business relationship with.

3b In parallel the Agent (B) initiates a covering payment to credit the account of Agent (E) with their correspondent (Agent D)

4 Agent E receives the payment instruction and process the payment on to Agent F. Alternatively they may have chosen to await until settlement occurred in Step 6 based upon their risk appetite.

5 Agent C processes the payment on Agent D, using a correspondent banking business relationship

6 Agent D receives the payment and credits the account of Agent E. Agent D produces an end of day account statement report. An optional real time notification e.g. advice of credit may have also been created at the time of the credit posting

7 Agent F receives the payment and credits the account of the Creditor, and may optionally provide a notification e.g. credit notification.



Note settlement of step 5 could alternative occur between Agent C and D using a Market Infrastructure..

High Level FI to FI Customer Credit Transfer involved a serial leg out of a cover method (pacs.009 COV)

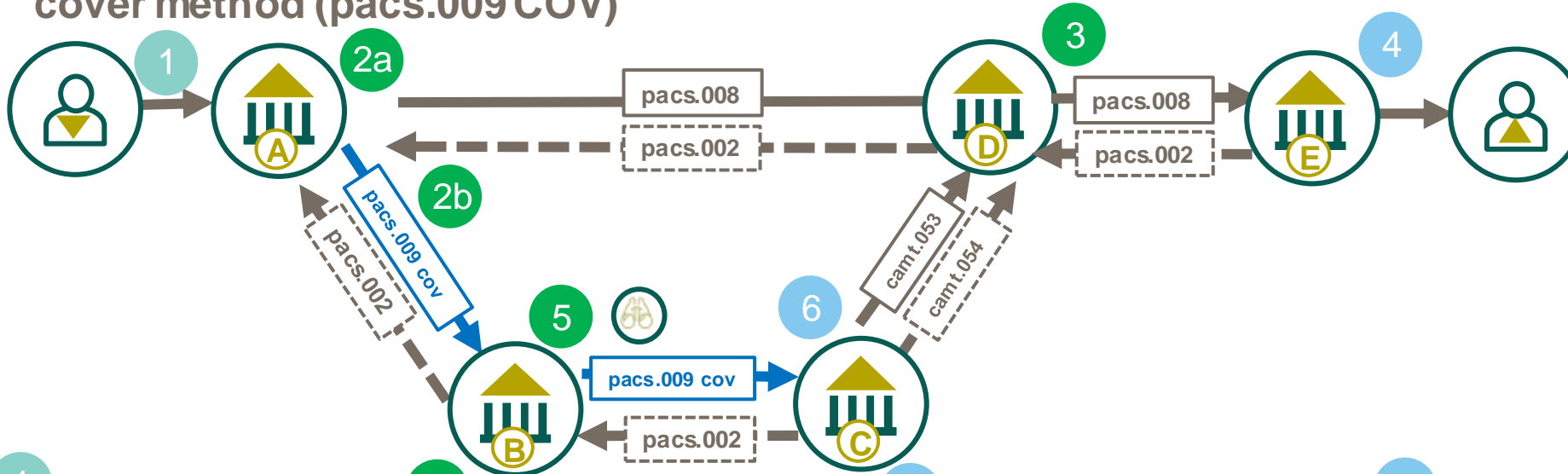

1 Debtor initiates a payment instruction to the Debtor Agent

2a Debtor Agent (A) initiates a payment using the cover method towards the Creditor Agent (E) by sending a direct pacs.008 to Agent D who they have business relationship with.

2b In parallel the Agent (A) initiates a covering payment to credit the account of Agent (D) with their correspondent (Agent C)

3 Agent D receives the payment instruction and process the payment on to Agent E. Alternatively they may have chosen to await until settlement occurred in Step 6 based upon their risk appetite.

4 Agent E receives the payment and credits the account of the Creditor, and may optionally provide a notification e.g. credit notification.

5 Agent B processes the payment on Agent C, using a correspondent banking business relationship

6 Agent C receives the payment and credits the account of Agent D. Agent C produces an end of day account statement report. An optional real time notification e.g. advice of credit may have also been created at the time of the credit posting



Note settlement of step 5 could alternative occur between Agent B and C using a Market Infrastructure..

pacs.002

FI to FI Payment Status Report



pac.002 FI to FI Payment Status Report

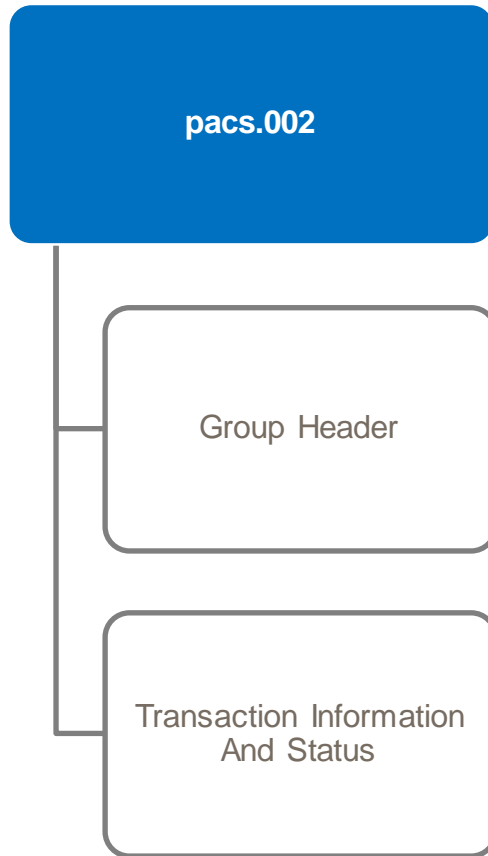

The Financial Institution To Financial Institution Payment Status Report message is sent by an instructed agent to the previous party in the payment chain. It is used to inform this party about the positive or negative status of an instruction. It is also used to report on a pending instruction

High Level message flow example resulting from a FI to FI Customer Payment (pacs.008)

pacs.002

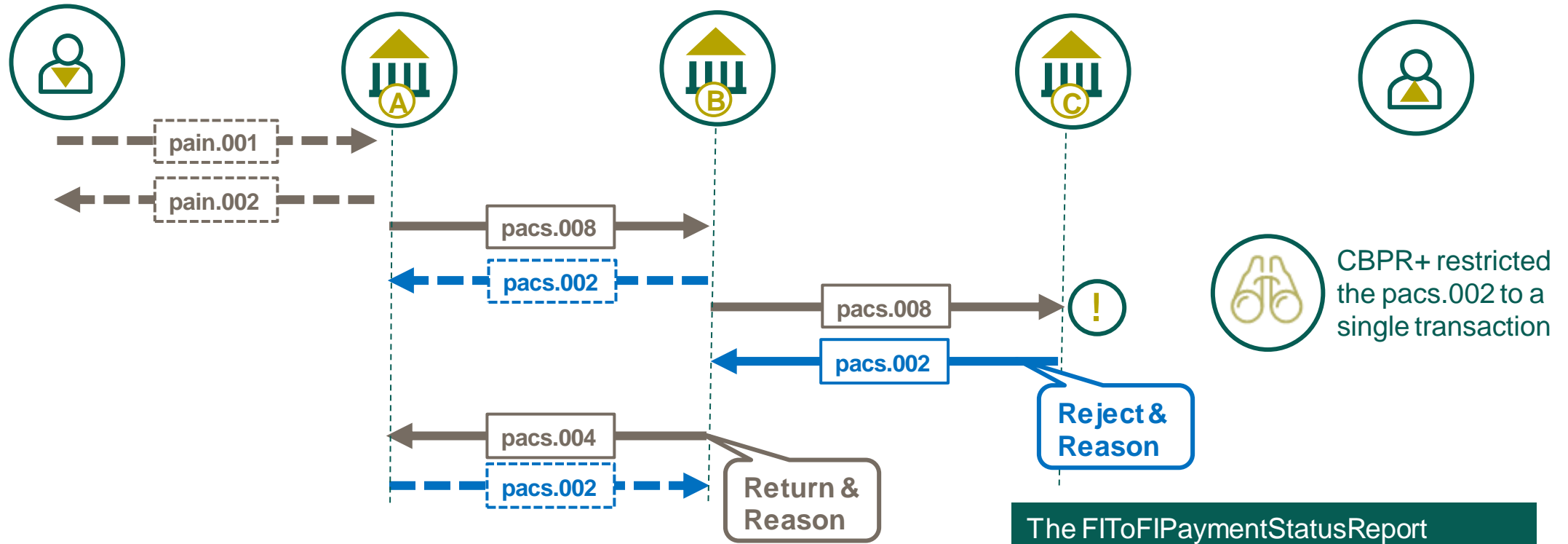

 The code list representing the *Payment Transaction Status* is part of the ISO 20022 external code list

The FIToFIPaymentStatusReport message is sent by an instructed agent to the previous party in the payment chain. It is used to inform this party about the positive or negative status of an instruction. It is also used to report on a pending instruction.



High Level serial message flow

pac.002

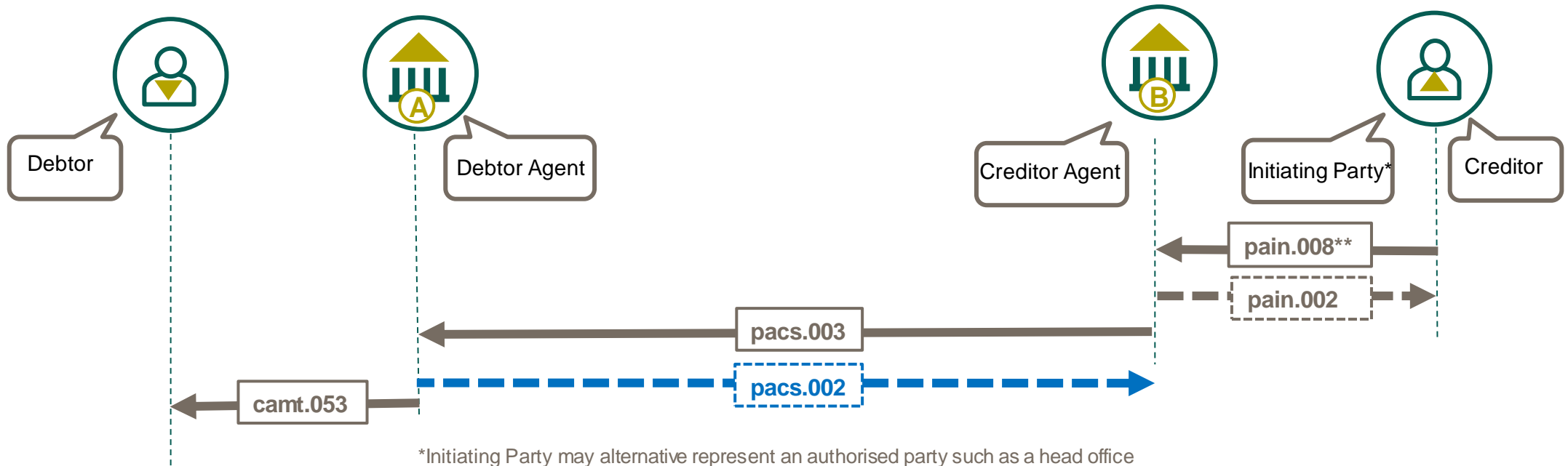

*Initiating Party may alternative represent an authorised party such as a head office
**or other proprietary method for instructing a direct debit initiation request.

The FIToFIPaymentStatusReport message is sent by an instructed agent to the previous party in the payment chain. It is used to inform this party about the positive or negative status of an instruction. It is also used to report on a pending instruction.



*Noting in CGI-MP pain.008 may also be sent by the Initiating Party/Creditor directly to the Creditor Agent which is outside of the scope of CBPR+.

Group Header



pac002 FI to FI Payment Status Report - Message Identification

Min 1 – Max 1

Each ISO 20022 payment message has a **Message Identification** element, located in the Group Header. This **35 character** identifier is a point-to-point reference used to unambiguously identify the message.

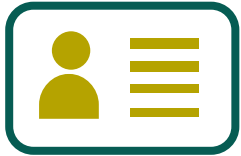

For Payment Clearing and Settlement (pac002) messages the Message Identification has no exact equivalent in the legacy MT payment message. However, the Sender's Reference (Field 20) could be considered a similar comparison where a pac002 message contains a single Transaction.

Group Header → Message Identification

pac002 FI to FI Payment Status Report - DateTime

Min 1 – Max 1

The pac002 message **Creation Date** captures the date and time which the message was created.

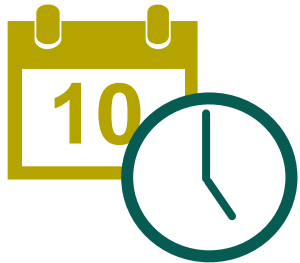

CBPR+ usage guidelines mandate the time zone that the time represents as an offset against Universal Time Coordinated (UTC):

Local time with UTC offset `YYYY-MM-DDThh:mm:ss.sss+/-hh:mm`

- For example: `2002-10-10T12:00:00-05:00` (noon/midday on 10 October 2002, Central Daylight Savings Time as well as Eastern Standard Time in the U.S.)



All CBPR+ time elements need offset against UTC. Milliseconds are optional.

Transaction Information and Status



pac.002 FI to FI Payment Status Report – Original Group Information

Min 1 – Max 1

The pac.002 FI to FI Payment Status Report uses elements in the **Original Group Information** to capture the message identifier and message name of the underlying payment the *Payment Status Report* relates to. The mandatory **Original Message Identification** contains the point-to-point reference, and the mandatory **Original Message Name Identification** contains the message name of the underlying payment being reported upon. Optionally the **Original Creation Date Time** can also be captured.

For example:

Original Message Name Identification “pac.008.001.08” confirms the Status Report is of a pac.008 Financial Institution to Financial Institution Customer Credit Transfer. Whereas “pac.009.001.08” confirms the Status Report is of a pac.009 Financial Institution Credit Transfer.

 Note: the xx in the CBPR+ Usage Guideline represents the message version of the message received for example pac.008.001.08

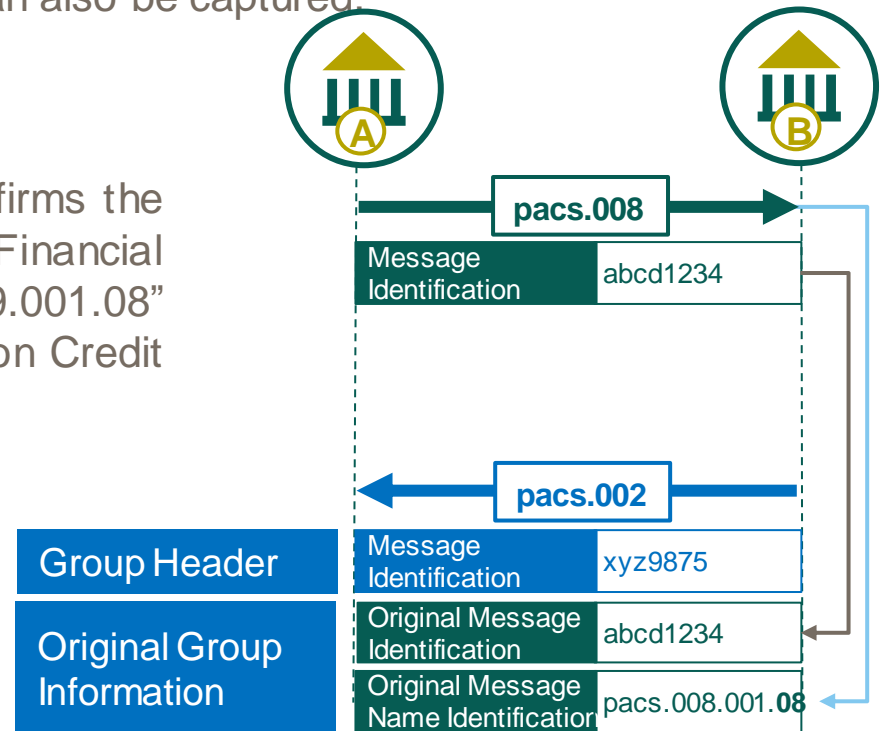

pac.002 FI to FI Payment Status Report – Original elements

The pac.002 *FI to FI Payment Status Report* also uses a number of other **Original** elements in the **Transaction Information And Status** to capture information from the underlying payment that the *Payment Status Report* relates to.

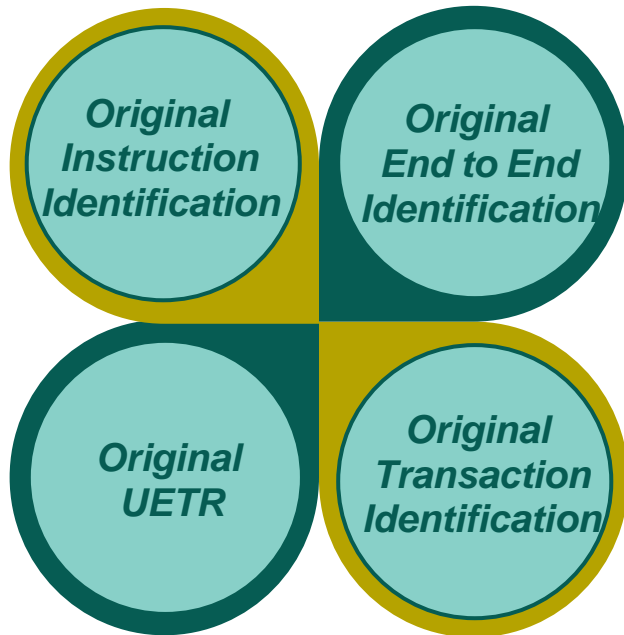

Mandatory element (in addition to *Original Message identification* and *Original Message Name Identification* described on the previous page) include:

Original End to End Identification

Min 1 – Max 1

Original UETR

Min 1 – Max 1

Min 0 – Max 1

Optionally **Original Transaction Identification** and **Original Instruction Identification** may also be used.

Min 0 – Max 1

These Original elements enables the **Instructed Agent** in the pac.002 *Payment Status Report* to associate the Payment Status with the payment they originally sent.

Transaction Information and Status

Original Instruction Identification

Original End to End Identification

Original UETR

Original Transaction

pac.002 FI to FI Payment Status Report – Transaction Status and Status Reason Information

Min 1 – Max 1

The pac.002 *FI to FI Payment Status Report* **Transaction Status** utilizes the externalized ISO *Payment Transaction Status* code list to provide a status update on a pac message previously received. The *Transaction Status* element is arguable the most significant/core parts of the pac.002 and optionally may further be complimented with **Status Reason Information**.

Min 0 – Max 1



The nested **Status Reason Information** enable the optional inclusion of:
Originator – the party that issues the status. Typically, the pac.002 Instructing Agent and therefore Originator is not necessary.

Reason – which utilizes either an ISO external Status Reason code or a proprietary reason. For example, **AC04** 'Closed Account Number' would compliment a RJCT (Reject) Transaction Status.

Additional Information – a text element to provide further status reason information, necessary where the *Reason* code is NARR



Note: A **Reason** code must be provided where the **Transaction Status** RJCT (Reject) code is used.

The next two slides take a look at:

- The code relevant to CBPR+ Payment Statuses, the codes description and the High Level Use Case.
- Logical order in which these codes may be used in one or multiple Payment Status Report updates.



pac002 FI to FI Payment Status Report - Payment Transaction Status Code

Definitions and High Level Use Cases

Code	Name	ISO Definition	High Level Use Case
ACCC	AcceptedSettlementCompleted	Settlement on the creditor's account has been completed.	Sent by Creditor Agent to confirm the settlement on the creditor's account
ACCP	AcceptedCustomerProfile	Preceding check of technical validation was successful. Customer profile check was also successful.	Sent by any Agent in the payment chain to confirm acceptance prior to technical validation.
ACFC	AcceptedFundsChecked	Preceding check of technical validation and customer profile was successful and an automatic funds check was positive.	Sent by any Agent in the payment chain to confirm the technical validation/profile was positive and automatic funds check was positive.
ACIS	AcceptedandChequeIssued	Payment instruction to issue a cheque has been accepted, and the cheque has been issued but not yet been deposited or cleared.	Sent by any Agent in the payment chain to confirm a cheque has been issued as requested.
ACSC	AcceptedSettlementCompleted	Settlement has been completed.	Sent by the Any Agent to confirm settlement of a payment message leg.
ACSP	AcceptedSettlementInProgress	All preceding checks such as technical validation and customer profile were successful and therefore the payment initiation has been accepted for execution.	Sent by any Agent to the to confirm the payment is accepted following technical validations being successfully completed.
ACTC	AcceptedTechnicalValidation	Authentication and syntactical and semantical validation are successful	Sent by any Agent in the payment chain to the previous Agent to confirm the payment is accepted following technical validations being successfully completed.
ACWC	AcceptedWithChange	Instruction is accepted but a change will be made, such as date or remittance not sent.	Sent by any Agent in the payment chain to the previous Agent to confirm the payment is accepted following amendments being made.
ACWP	AcceptedWithoutPosting	Payment instruction included in the credit transfer is accepted without being posted to the creditor customer's account.	Sent by Creditor Agent to the previous Agent to confirm the acceptance of payment without settlement on the creditor's account,
CPUC	CashPickedUpByCreditor	Cash has been picked up by the Creditor.	Sent by Creditor Agent to the previous Agent to confirm that the cash collection has been picked up by the Creditor,
PDNG	Pending	Payment initiation or individual transaction included in the payment initiation is pending. Further checks and status update will be performed.	Sent by any Agent in the payment chain to the previous Agent as an interim status whilst other validations are performed.
RCVD	Received	Payment initiation has been received by the receiving agent.	Sent by Any Agent to the previous Agent as confirmation that their Customer Credit Transfer initiation request has been received by the payment engine.
RJCT	Rejected	Payment initiation or individual transaction included in the payment initiation has been rejected.	Sent by Any Agent to inform the previous Agent that their Customer Credit Transfer has been rejected.

Payment Transaction Status – High Level logical process flow

The pacS.002 *Payment Transaction Status* element facilitates updates to the previous Agent on changes to the status of the payment. Such Status Information messages (pacS.002), with the exception of **reject code RJCT** which is **mandatory in CBPR+**, are bilateral agreed, where upon a variety of these Transaction Statuses may be used by the Instructed Agent at different stages of the payment processing.

This diagram illustrates the logical order in which these codes may be used during the processing of the Payment Clearing And Settlement message (pacS) and the role of the Agent in providing these status.

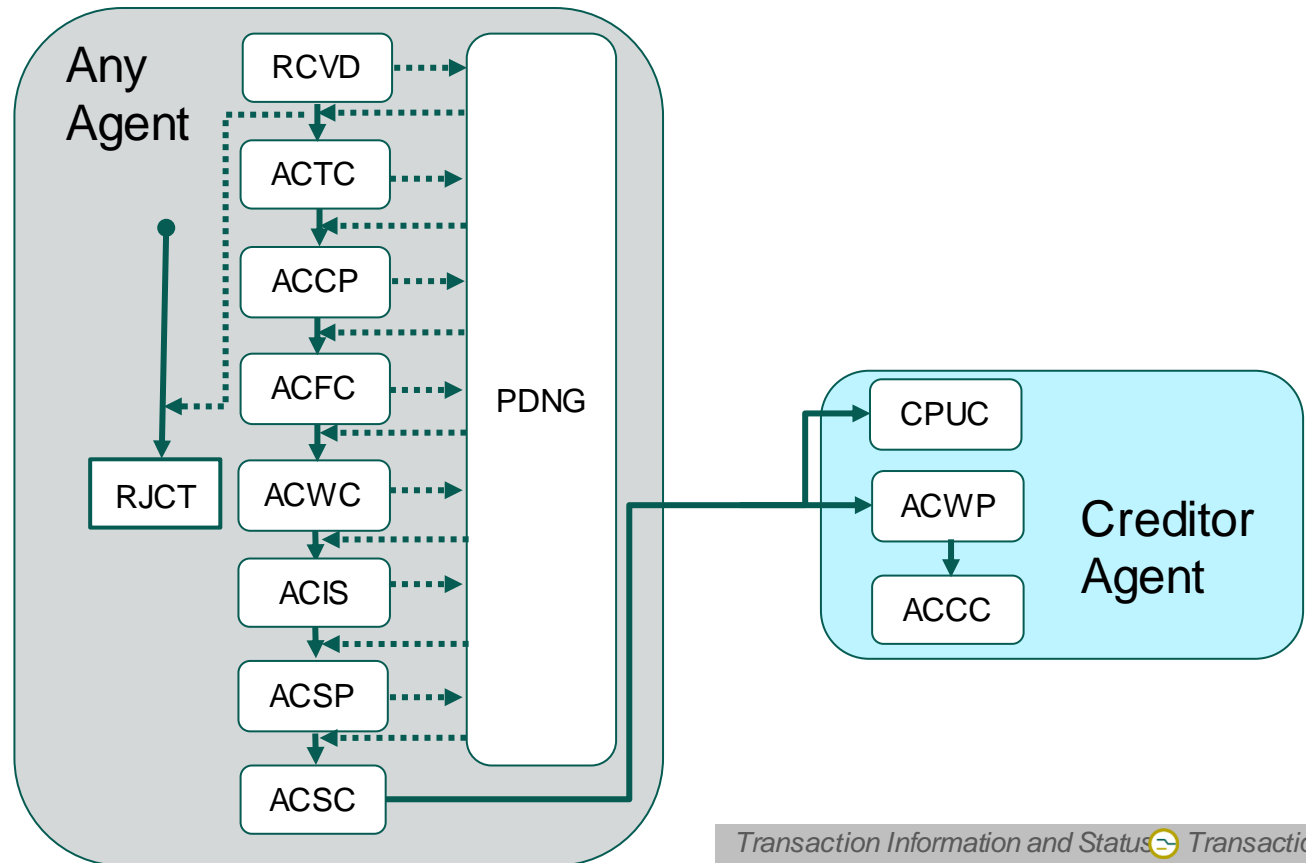

paces.002 FI to FI Payment Status Report - Reject Reason Codes

Definitions and High Level Use Cases

Code	Name	ISO Definition	High Level Use Case
AC01	IncorrectAccountNumber	Format of the account number specified is not correct or Account number is missing	Sent by Instructed Agent when a settlement account number is incorrect
AC02	InvalidDebtorAccountNumber	Debtor account number invalid or missing	Sent by Instructed Agent when Debtor account number is incomplete
AC04	ClosedAccountNumber	Account number specified has been closed on the bank of account's books	Sent by Creditor Agent when the Creditor account number is closed
AC06	BlockedAccount	Account specified is blocked, prohibiting posting of transactions against it.	Sent by Creditor Agent when Creditor account is blocked from posting credit entries. Sent by Instructed Agent when a settlement account is blocked
AC07	ClosedCreditorAccountNumber	Creditor account number closed	Sent by Creditor Agent when account number is closed. <i>CBPRplus recommend using AC04, but support AC07 to remain interoperable with other clearing systems.</i>
AC13	InvalidDebtorAccountType	Debtor account type is missing or invalid	Sent by Instructed Agent when Debtor account type element is incorrect
AGNT	IncorrectAgent	Agent in the payment workflow is incorrect	Sent by Instructed Agent when an agent in the payment transaction has an incorrect identification element
AG01	TransactionForbidden	Transaction forbidden on this type of account (formerly NoAgreement)	Sent by Instructed Agent when the type of payment transaction is not allowed for the specified account
AG07	UnsuccessfulDirectDebit	Debtor account cannot be debited for a generic reason. Code value may be used in general purposes and as a replacement for AM04 if debtor bank does not reveal its customer's insufficient funds for privacy reasons	Sent by Debtor Agent of a Direct Debit message, when debtor account can not be debited
AM02	NotAllowedAmount	Specific transaction/message amount is greater than allowed maximum	Sent by Instructed Agent when payment amount is above an allowed amount. For example the clearing system with a upper amount threshold



paces.002 FI to FI Payment Status Report - Reject Reason Codes

Definitions and High Level Use Cases

Code	Name	ISO Definition	High Level Use Case
AM03	NotAllowedCurrency	Specified message amount is a non processable currency outside of existing agreement	Sent by Instructed Agent when the currency of the payment is not allowed within the existing business agreement
AM04	InsufficientFunds	Amount of funds available to cover specified message amount is insufficient.	Sent by Instructed Agent when there is not sufficient funds to settle the payment transaction.
AM05	Duplication	Payment is a duplicate of another payment	Sent by Instructed Agent when the payment is a duplicate. <i>CBPRplus recommend using DUPL, but support AM05 to remain interoperable with other clearing systems.</i>
AM06	TooLowAmount	Specified transaction amount is less than agreed minimum.	Sent by Instructed Agent when the payment amount is below a minimum amount.
AM07	BlockedAmount	Amount specified in message has been blocked by regulatory authorities	Sent by Instructed Agent when the payment amount is blocked by regulators
AM09	WrongAmount	Amount received is not the amount agreed or expected	Sent by Instructed Agent when the payment amount is incorrect
BE01	InconsistenWithEndCustomer	Identification of end customer is not consistent with associated account number (formerly CreditorConsistency).	Sent by Creditor Agent when there is an inconsistency between the Creditor's identification and the account number
BE04	MissingCreditorAddress	Specification of creditor's address, which is required for payment, is missing/not correct (formerly IncorrectCreditorAddress).	Sent by Instructed Agent when the Creditor's address is missing Sent by Creditor Agent when the Creditor's address is incorrect
BE05	UnrecognisedInitiatingParty	Party who initiated the message is not recognised by the end customer	Sent by Creditor Agent when the initiating party is unknown to the beneficiary
BE07	MissingDebtorAddress	Specification of debtor's address, which is required for payment, is missing/not correct.	Sent by Instructed Agent when the address of the Debtor is missing or incorrect



paces.002 FI to FI Payment Status Report - Reject Reason Codes

Definitions and High Level Use Cases

Code	Name	ISO Definition	High Level Use Case
BE10	InvalidDebtorCountry	Debtor country code is missing or invalid	Sent by Instructed Agent when the country code of the Debtor is missing or incorrect
BE11	InvalidCreditorCountry	Creditor country code is missing or invalid	Sent by Instructed Agent when the country code of the Creditor is missing or incorrect
BE16	InvalidDebtorIdentificationCode	Debtor or Ultimate Debtor identification code missing or invalid	Sent by Instructed Agent when the identification of the Debtor or Ultimate Debtor is missing or incorrect
BE17	InvalidCreditorIdentificationCode	Creditor or Ultimate Creditor identification code missing or invalid	Sent by the Instructed Agent when the identification of the Creditor or Ultimate Creditor is missing or incorrect
CN01	AuthorisationCancelled	Authorisation is cancelled.	Sent by Instructed Agent when a third party debit authorisation has been cancelled or is not in place.
CNOR	Creditor bank is not registered	Creditor bank is not registered under this BIC in the Clearing Settlement Mechanism (CSM)	Sent by Instructed Agent when the Creditor Agent is not reachable in the Market Infrastructure (CSM) and an appropriate correspondent can not be determined.
CURR	IncorrectCurrency	Currency of the payment is incorrect	Sent by the Creditor Agent when the Interbank Settlement Amount Currency is not the same as the Creditor account currency and a currency conversion is not accepted on the Creditor's account.
CUST	RequestedByCustomer	Cancellation requested by the Debtor	Sent by Instructed Agent upon request by Debtor. <i>CBPRplus recommend using FOCR, but support CUST to remain interoperable with other clearing systems.</i>
DT01	InvalidDate	Invalid date (eg, wrong or missing settlement date)	Sent by Instructed Agent when the settlement date is in the past and an agreement is in place to reject rather than apply the next possible value date.
DT04	FutureDateNotSupported	Future date not supported	Sent by Instructed Agent when a future settlement date is not supported or appear to be an error e.g. is the wrong year.



paces.002 FI to FI Payment Status Report - Reject Reason Codes

Definitions and High Level Use Cases

Code	Name	ISO Definition	High Level Use Case
DUPL	DuplicatePayment	Payment is a duplicate of another payment	Sent by Instructed Agent when the payment is a duplicate
ERIN	ERIOptionNotSupported	The Extended Remittance Information (ERI) option is not supported.	Sent by Instructed Agent when extended Remittance information (Related Remittance Information) is not supported or bilaterally/multilaterally agreed
ED05	SettlementFailed	Settlement of the transaction has failed.	Sent by Instructed Agent when the settlement of payment has failed or been unsuccessful.
FF03	InvalidPaymentTypeInformation	Payment Type Information is missing or invalid. Generic usage if cannot specify Service Level or Local Instrument code	Sent by Instructed Agent when the Payment Type Information (Instruction Priority, Clearing Channel) provided for the payment is incorrect or not supported.
FF04	InvalidServiceLevelCode	Service Level code is missing or invalid	Sent by Instructed Agent when the Payment Type Information Service Level provided for the payment is incorrect or not supported
FF05	InvalidLocalInstrumentCode	Local Instrument code is missing or invalid	Sent by Instructed Agent when the Payment Type Information Local Instrument provided for the payment is incorrect or not supported
FF06	InvalidCategoryPurposeCode	Category Purpose code is missing or invalid	Sent by Instructed Agent when the Payment Type Information Category Purpose provided for the payment is incorrect or not supported
FF07	InvalidPurpose	Purpose is missing or invalid	Sent by Instructed Agent when the Purpose provided for the payment is either missing or incorrect
FOCR	FollowingCancellationRequest	Return following a cancellation request	Sent by Instructed Agent that has accepted a payment cancellation request (camt.056) and subsequently is rejecting the unsettled payment instruction.
FR01	Fraud	Returned as a result of fraud.	Sent by Instructed Agent when the payment is identified as fraudulent.
MD01	NoMandate	No Mandate	Sent by Instructed Agent when a Direct Debit message has no mandate in place.



paces.002 FI to FI Payment Status Report – Reject Reason Codes

Definitions and High Level Use Cases

Code	Name	ISO Definition	High Level Use Case
MD02	MissingMandatoryInformationInMandate	Mandate related information data required by the scheme is missing.	Sent by Instructed Agent when information required by the clearing scheme is missing.
MD05	CollectionNotDue	Creditor or creditor's agent should not have collected the direct debit	Sent by Instructed Agent when a Direct Debit collection was not due
MD07	EndCustomerDeceased	End customer is deceased.	Sent by Creditor Agent when the Creditor or Ultimate Creditor is deceased
MS02	NotSpecifiedReasonCustomerGenerated	Reason has not been specified by end customer	Sent by Creditor Agent where instructed to reject by the Creditor, but no reason was specified
MS03	NotSpecifiedReasonAgentGenerated	Reason has not been specified by agent.	Sent by Instructed Agent but no reason is specified
NARR	Narrative	Reason is provided as narrative information in the additional reason information.	Sent by Instructed Agent the reason is provided as narrative information. Only to be used where no other code is appropriate! (i.e. exceptional circumstances)
NOAS	NoAnswerFromCustomer	No response from Beneficiary	Sent by Instructed Agent when the Creditor did not respond to query for additional information in order that the payment could be credited e.g. currency control documentation.
NOCM	Not compliant (more generic)	Customer account is not compliant with regulatory requirements, for example FICA (in South Africa) or any other regulatory requirements which render an account inactive for certain processing.	Sent by Instructed Agent when the Creditor account is not compliant with certain regulatory requirements.
RC01	BankIdentifierIncorrect	Bank Identifier code specified in the message has an incorrect format (formerly IncorrectFormatForRoutingCode).	Sent by Instructed Agent when an incorrect BIC has been used in the payment
RC03	InvalidDebtorBankIdentifier	Debtor bank identifier is invalid or missing	Sent by Instructed Agent when the Debtor Agent identification is incorrect or missing



paces.002 FI to FI Payment Status Report - Reject Reason Codes

Definitions and High Level Use Cases

Code	Name	ISO Definition	High Level Use Case
RC04	InvalidCreditorBankIdentifier	Creditor bank identifier is invalid or missing	Sent by Instructed Agent when the Creditor Agent identification is incorrect or missing
RC08	InvalidClearingSystemMemberIdentifier	ClearingSystemMemberIdentifier is invalid or missing. Generic usage if cannot specify between debit or credit account	Sent by Instructed Agent when the clearing system member identification for an Agent is incorrect
RC11	InvalidIntermediaryAgent	Intermediary Agent is invalid or missing	Sent by Instructed Agent when the intermediary agent identification is incorrect
RF01	NotUniqueTransactionReference	Transaction reference is not unique within the message.	Sent by Instructed Agent when the transaction reference (UETR and Instruction Identification) are not unique
RR01	Missing Debtor Account or Identification	Specification of the debtor's account or unique identification needed for reasons of regulatory requirements is insufficient or missing	Sent by Instructed Agent when the Debtor identification or debtor account is missing, or the information provided are not sufficient
RR02	Missing Debtor Name or Address	Specification of the debtor's name and/or address needed for regulatory requirements is insufficient or missing.	Sent by Instructed Agent since the Debtor name or Address is missing, or information provided is not sufficient
RR03	Missing Creditor Name or Address	Specification of the creditor's name and/or address needed for regulatory requirements is insufficient or missing.	Sent by Instructed Agent since the Creditor name or Address is missing, or information provided is not sufficient
RR04	Regulatory Reason	Regulatory Reason	Sent by Instructed Agent due to any unspecified regulatory reason
RR05	RegulatoryInformationInvalid	Regulatory or Central Bank Reporting information missing, incomplete or invalid.	Sent by Instructed Agent when the reporting information required by the central bank or reporting authority is missing or not complete
RR06	TaxInformationInvalid	Tax information missing, incomplete or invalid.	Sent by Instructed Agent where required tax information is missing, not valid or not complete



pacs.002 FI to FI Payment Status Report - Reject Reason Codes

Definitions and High Level Use Cases

Code	Name	ISO Definition	High Level Use Case
RR07	RemittanceInformationInvalid	Remittance information structure does not comply with rules for payment type.	Sent by Instructed Agent since the remittance information is incorrect
RR08	RemittanceInformationTruncated	Remittance information truncated to comply with rules for payment type.	Sent by Instructed Agent where the Structured Remittance Information has not been bilaterally or multilaterally agreed, which or has resulted in truncation
RR09	InvalidStructuredCreditorReference	Structured creditor reference invalid or missing.	Sent by Instructed Agent when the structure of the creditor reference in the remittance information is invalid or missing
RR11	InvalidDebtorAgentServiceID	Invalid or missing identification of a bank proprietary service.	Sent by Instructed Agent where the proprietary identification for the Debtor is invalid or not understood
RR12	InvalidPartyID	Invalid or missing identification required within a particular country or payment type.	Sent by Instructed Agent where a proprietary party identification is considered invalid or not understood
RUTA	ReturnUponUnableToApply	Return following investigation request and no remediation possible.	Sent by Instructed Agent that is unsatisfied with the outcome of the unable to apply request and is subsequently rejecting the payment instruction. Alternatively it can be used by the original Creditor Agent when the creditor is unable to apply the transaction
TM01	InvalidCut off time	Associated message, payment information block, or transaction was received after agreed processing cut-off time.	Sent by Instructed Agent when the message was received after the agreed processing cut off time and an agreement is in place to reject rather than apply the next possible value date.
UPAY	UnduePayment	Payment is not justified.	Sent by Instructed Agent the payment is undue



pac002 FI to FI Payment Status Report – Pending Reason Codes

Definitions and High Level Use Cases

Code	Name	ISO Definition	High Level Use Case
G004	CreditPendingFunds	In a FIToFI Customer Credit Transfer: Credit to the creditor's account is pending, status Originator is waiting for funds provided via a cover. Update will follow from the Status Originator.	Optionally sent by the Creditor Agent when the cover has not been settled at the creditor agent account at the reimbursement agent



pac.002 FI to FI Payment Status Report – Effective Interbank Settlement Date

Min 0 – Max 1

The pac.002 *FI to FI Payment Status Report* optional **Effective Interbank Settlement Date** allows a choice of **Date** or **Date Time** to confirm when a point-to-point transaction is completed/effected.

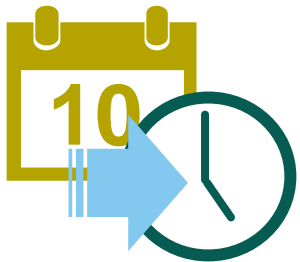

When **Date Time** is chosen CBPR+ usage guidelines mandate the time zone that the time represents as an offset against Universal Time Coordinated (UTC):

Local time with UTC offset YYYY-MM-DDThh:mm:ss.sss+/-hh:mm

- For example: 2002-10-10T12:00:00-05:00 (noon/midday on 10 October 2002, Central Daylight Savings Time as well as Eastern Standard Time in the U.S.)

pac.002 FI to FI Payment Status Report - Instructed and Instructing Agents

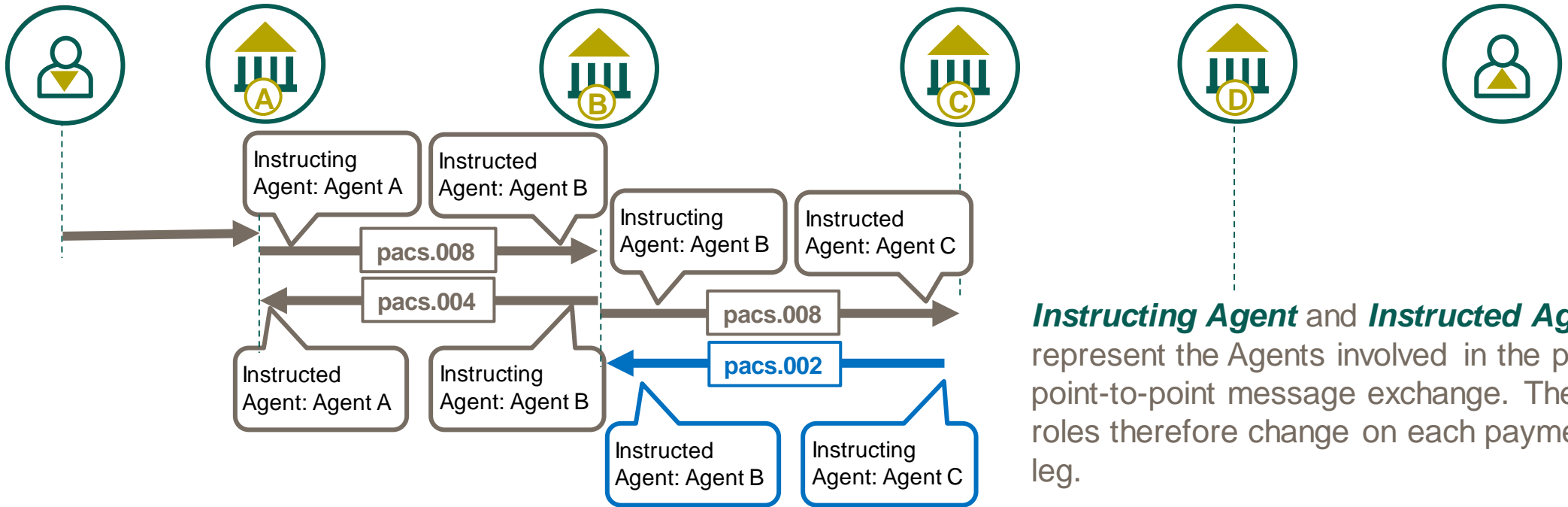

Instructing Agent and **Instructed Agent** represent the Agents involved in the pac. point-to-point message exchange. These roles therefore change on each payment leg.



Instructing Agent and *Instructed Agent* elements are required in all pac. messages

Credit Transfer Transaction Information

- Instructing Agent
- Instructed Agent



Index of pacs.002 Use Cases

Use case should be considered as a principal example whereby use case may be cross referenced e.g. a use case involving a Market Infrastructure can apply the Market Infrastructure legs to other use cases.

Serial Financial Institution to Financial Institution to Customer Credit Transfer

Use Case p.2.1.1 – High Level Payment Status Information (pacs.002) of multiple Payment Transaction Status updates

Use Case p.2.1.2 – High Level Rejection of an incomplete Customer Credit Transfer (pacs.008)

Serial Financial Institution Credit Transfer

Use Case p.2.2.1 – High Level Rejection of an incomplete Financial Institution Credit Transfer (pacs.009)

Cover Method Financial Institution to Financial Institution to Customer Credit Transfer

Use Case p.2.3.1.a – High Level Rejection of an incomplete payment using the cover method

Use Case p.2.3.1.b – High Level Rejection of an incomplete payment using the cover method

Financial Institution Direct Debit

Use Case p.2.4.1 – High Level Status Information of a Financial Institution Direct Debit

Use Case p.2.4.2 – High Level Rejection of a Financial Institution Direct Debit

Financial Institution to Financial Institution Customer Direct Debit

Use Case p.2.5.1 – High Level FI to FI Customer Direct Debit (pacs.003) successful settlement

Use Case p.2.5.2 – High Level FI to FI Customer Direct Debit (pacs.003) unsuccessful settlement

High Level Payment Status Information (pacs.002) of multiple Payment Transaction Status updates

An agent may provide multiple Payment Status Information updates (with different Transaction Status codes) where bilaterally agreed, throughout the payment processing lifecycle i.e. from receipt through to onward processing.

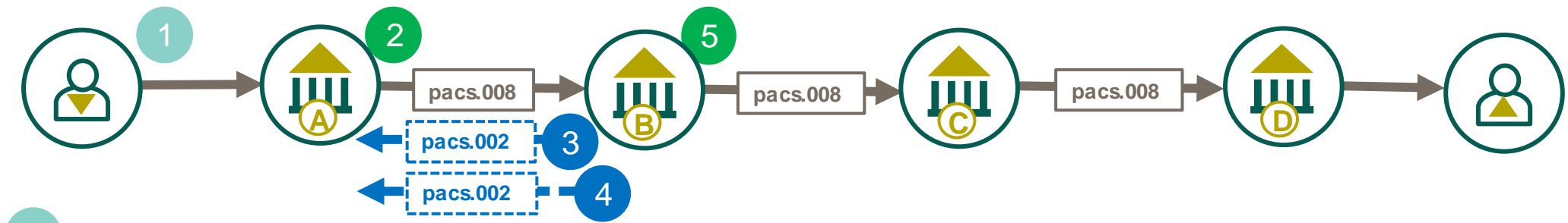

1 Debtor initiates a payment instruction to the Debtor Agent

2 Debtor Agent (A) initiates a serial payment towards the Creditor Agent (D) using Agents B & C as intermediaries

3 Agent B provides a status update ACTC (accepted technical validations are successful) to Agent A, based upon a bilateral agreement.

4 Agent B provides a further status update ACSP (accepted settlement in progress) to Agent A, based upon a bilateral agreement.

5 Agent B processes the payment on Agent C

 Where a **payment is rejected**, the use of the pacs.002 with the RJCT (Reject) status code is **mandatory**.



High Level Rejection of an incomplete Customer Credit Transfer (pacs.008)

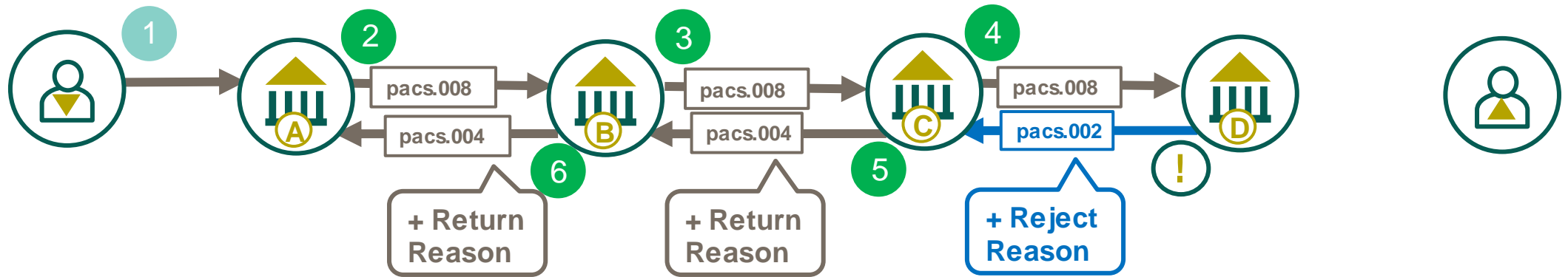

1 Debtor initiates a payment instruction to the Debtor Agent

2 Debtor Agent (A) initiates a serial payment towards the Creditor Agent (D) using Agents B & C as intermediaries

3 Agent B processes the payment on Agent C

4 Agent C processes the payment on Agent D

! Having received the payment Agent D recognises the payment can not be completed as requested e.g. the Creditor's account is closed. Agent D rejects the payment to Agent C using a Status information message (pacs.002) also including the return reason code.

5 Agent C return funds to Agent B, together with the reason code for return.

6 Agent B return funds to Agent A, together with the reason code for return.

High Level Rejection of an incomplete Financial Institution Credit Transfer (pacs.009)

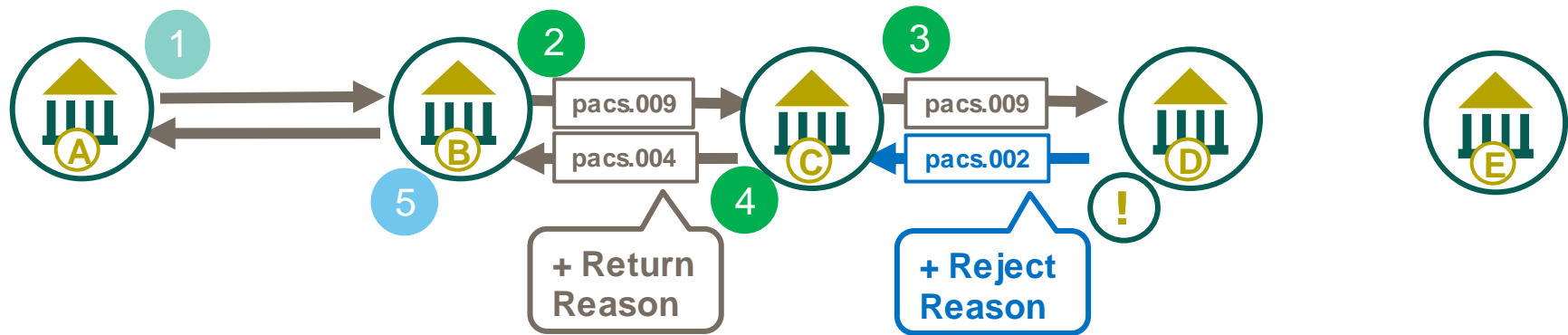

1 Agent A as the Debtor initiates a payment instruction to the Debtor Agent (Agent B)

2 Debtor Agent (B) debits the account of Agent A and initiates a serial payment towards the Creditor (Agent E) using Agents C as an intermediary.

2 Agent C processes the payment onto Agent D

! Having received the payment Agent D recognises the payment can not be completed as requested e.g. the Creditor's account is closed. Agent D rejects the payment to Agent C using a Status Information message (pacs.002) also including the reject code.

4 Agent C return funds to Agent B, together with the reason code for return.

5 Agent B advises Agent A of the return of payment together with the reason using the camt.053 and may optionally provide a notification e.g. credit notification.

High Level Rejection of an incomplete payment using the cover method

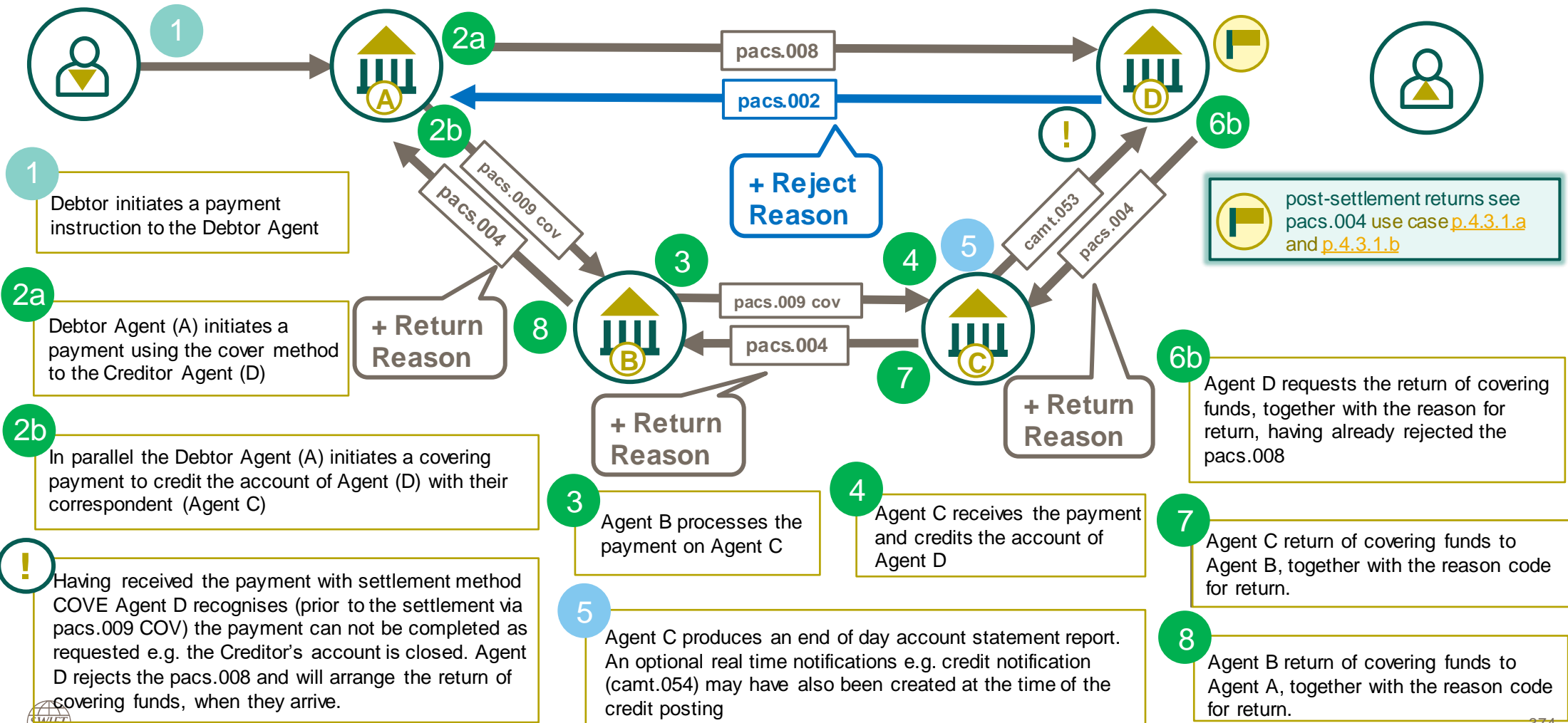

post-settlement returns see `pac.004` use case [p.4.3.1.a](#) and [p.4.3.1.b](#)



High Level Rejection of an incomplete payment using the cover method

Use Case p.2.3.1.b

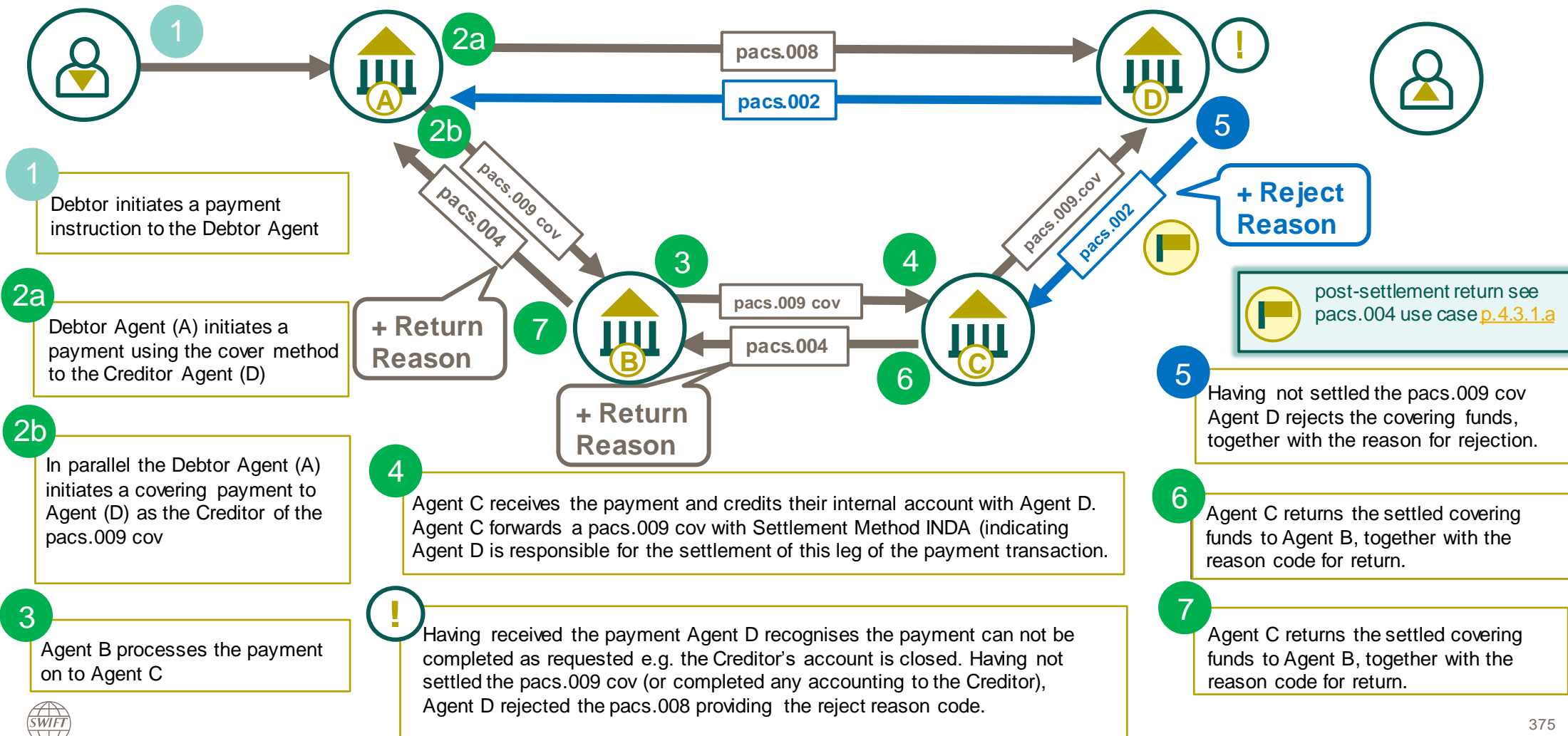

High Level Status Information of a Financial Institution Direct Debit (pacs.010)

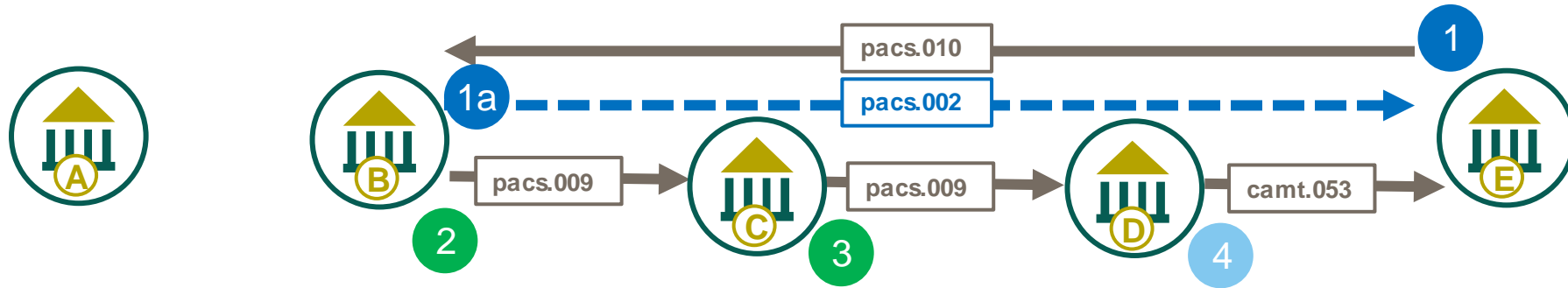

1 Agent E initiates a Direct Debit instruction to debit Agent A's account

2 Debtor Agent (B) initiates a serial payment towards the Creditor Agent (E) using Agents B & C as intermediaries

4 Agent D credits the account of the Creditor (Agent E), and may optionally provide a notification e.g. credit notification in addition to an account statement (camt.053)

1a Agent B provides a positive status update to Agent E

3 Agent C processes the payment on Agent D

High Level Rejection of a Financial Institution Direct Debit (pacs.010)

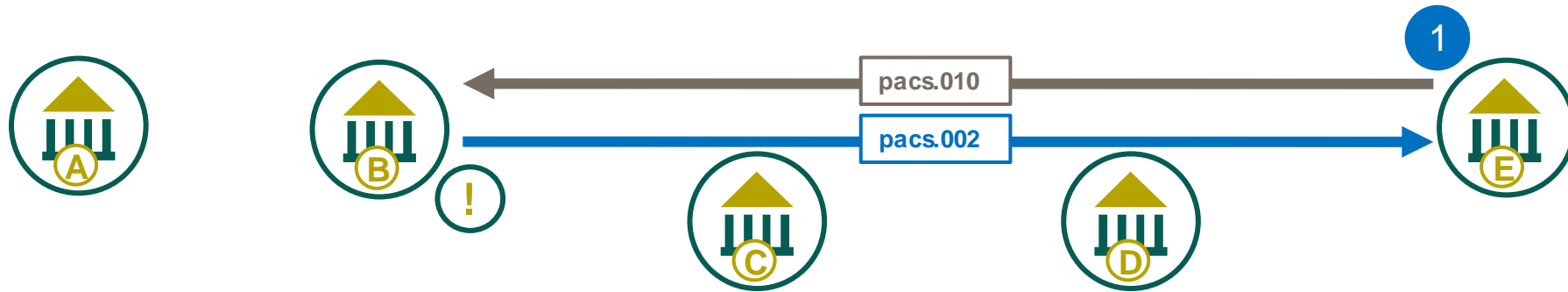

1

Agent D initiates a Direct Debit instruction to debit Agent A's account

!

Debtor Agent (B) rejects the instruction, using a pacs.002, as no mandate agreement is in place.

High Level FI to FI Customer Direct Debit (pacs.003) successful settlement

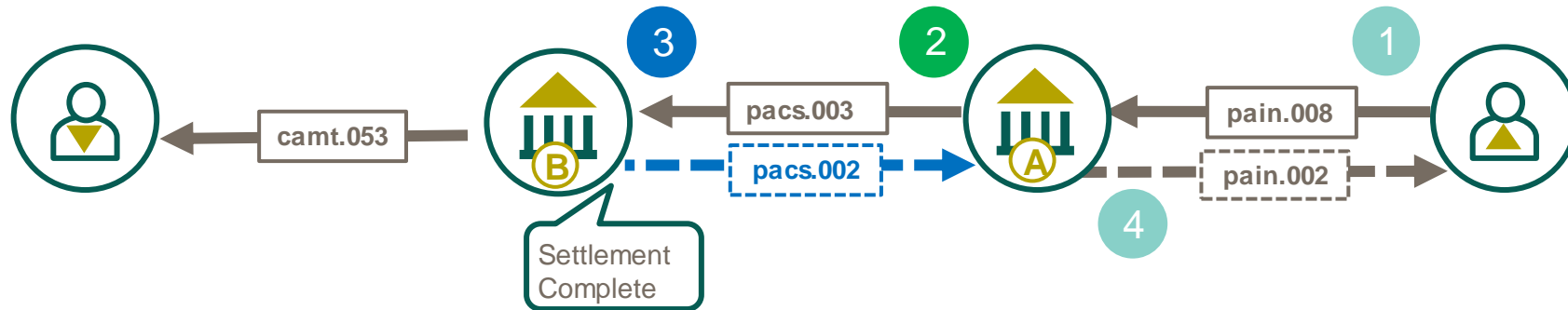

1 Creditor initiates a direct debit instruction to the Creditor Agent

2 Creditor Agent (A) initiates a direct debit collection by sending a `pacs.003` message to the Debtor Agent with the settlement method "INDA"

3 The Debtor Agent debits the account of the Debtor, and may optionally provide a notification e.g. debit notification in addition to an account statement (`camt.053`). The Debtor Agent also provides a status update `ACSC` (accepted settlement completed) to the Creditor Agent.

4 Creditor Agent (A) relays the status `ACSC` (accepted settlement completed) to the Initiating Party, based upon a bilateral agreement

High Level FI to FI Customer Direct Debit (pacs.003) unsuccessful settlement

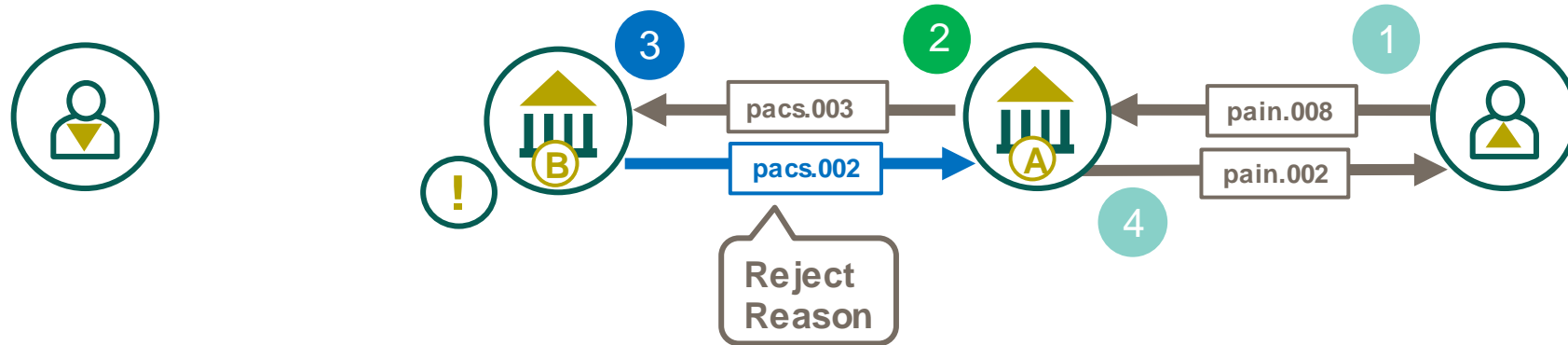

1 Creditor initiates a direct debit instruction to the Creditor Agent

2 Creditor Agent (A) initiates a direct debit collection by sending a `pacs.003` message to the Debtor Agent with the settlement method "INDA"

3 The Debtor Agent fails to debit the account of the Debtor (e.g., account is closed). The Debtor Agent provides a status update RJCT (Rejected) with the rejection reason information.

4 Creditor Agent (A) relays the status RJCT (Rejected) to the Initiating Party with the rejection reason information

pac.004

Payment Return



pac004 Payment Return

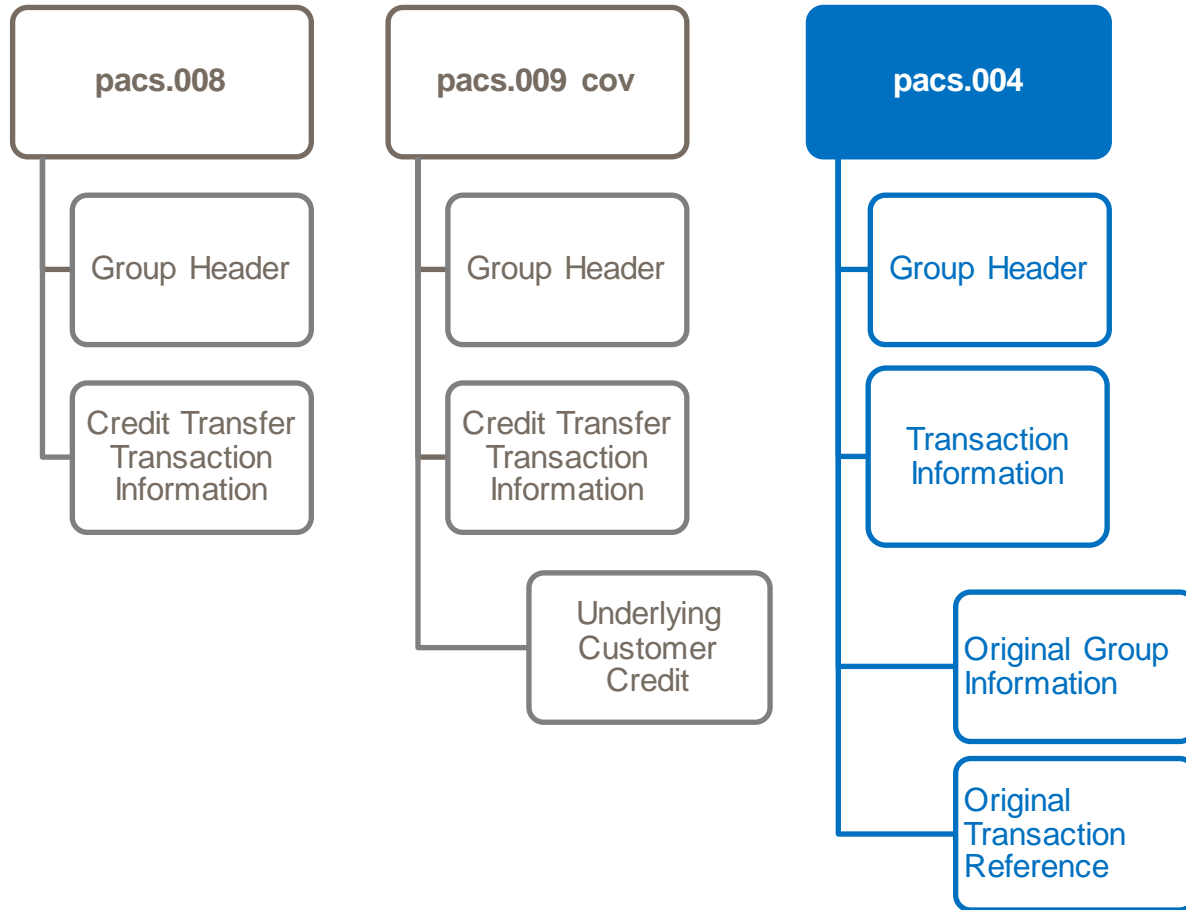

In a similar structure to the pac009 (cov) underlying Customer Credit Transfer, the pac004 Payment Return message has amongst other elements Original Group Information which captures original information such as the Original UETR and Original Interbank Settlement Amount etc. and an Original Transaction Reference which contain the key elements of the original payment e.g. Debtor, Creditor etc.



High Level message flow example resulting from a FI to FI Customer Payment (pacs.008)

pacs.004

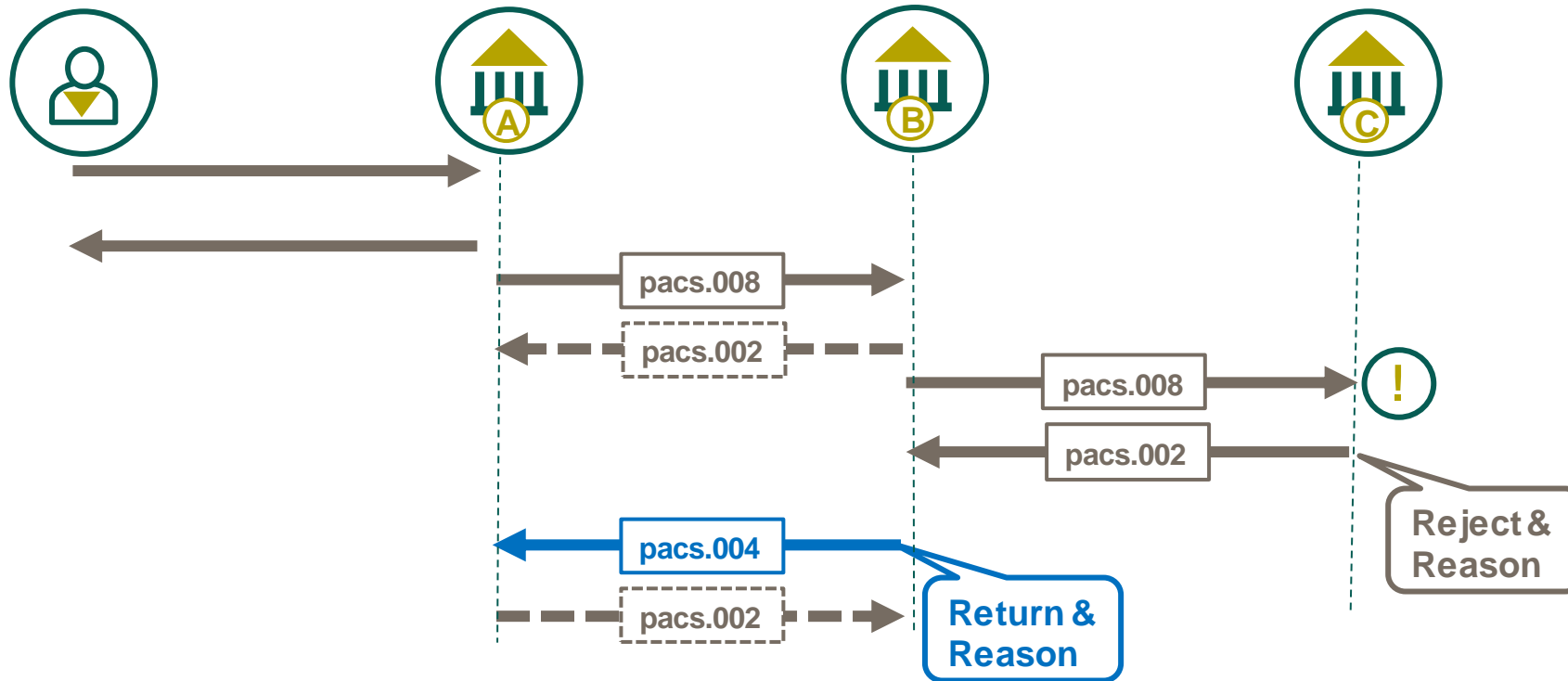

The PaymentReturn message is sent by an agent to the previous agent in the payment chain to undo a payment previously settled.



In the unlikely event that a pacs.004 is instructed by mistake, the best practice is to allow the Payment Return to complete and request (using Exceptions and Investigations) the instruction to be re-initiated. The Payment Return of a Payment Return should be avoided, as should the Rejection Status Notification of Payment Return.



Group Header



pac004 Payment Return - Message Identification

Min 1 – Max 1

Each ISO 20022 payment message has a **Message Identification** element, located in the Group Header. This **35 character** identifier is a point-to-point reference used to unambiguously identify the message.



For Payment Clearing and Settlement (pac004) messages the Message Identification has no exact equivalent in the legacy MT payment message. However, the MT 202 Sender's Reference (Field 20) could be considered a similar comparison where a pac004 message contains a single Transaction.



Each transaction's *Credit Transfer Transaction Information* contains a variety of nested *Payment Identification* elements to capture reference related to the individual transaction such as a UETR (Unique End-to-end Transaction Reference)

Group Header ➤ Message Identification

pac004 Payment Return– Creation DateTime

Min 1 – Max 1

The pac004 message **Creation Date** captures the date and time which the message was created.

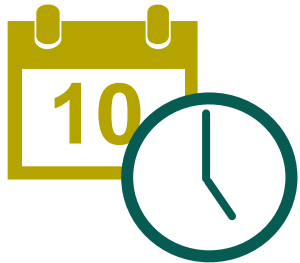

CBPR+ usage guidelines mandate the time zone that the time represents as an offset against Universal Time Coordinated (UTC):

Local time with UTC offset `YYYY-MM-DDThh:mm:ss.sss+/-hh:mm`

- For example: `2002-10-10T12:00:00-05:00` (noon/midday on 10 October 2002, Central Daylight Savings Time as well as Eastern Standard Time in the U.S.)



All CBPR+ time elements need offset against UTC. Milliseconds are optional.

pac.004 Payment Return - Number of Transactions

Min 1 – Max 1

The pac.004 message ***Number of Transactions*** captures the number of individual transaction contained within the message.



The number of transactions in CBPR+ payment usage guidelines is fixed to 1.



Single transactions in the CBPR+ payment usage guidelines enable a transaction to be managed and unlocks highly automated, frictionless, instant payments, supporting the next generation of innovation.

Group Header ▶ *Number of Transactions*

pac.004 Payment Return – Settlement Information

Min 1 – Max 1

The pac.004 **Settlement Method** element within the Group Header **Settlement Information**, includes one of the embedded codes to indicate how the payment message will be settled.

The **Settlement Method** element in the pac.004 allows a choice of an embedded code.



INDA indicate this Customer Credit Transfer will be settlement by the Instructed Agent (as the Account Servicing Institution) The account held at the Instructed Agent may captured in the dedicated **Settlement Account** element.

INGA indicate this Customer Credit Transfer has already been settlement by the Instructing Agent, who has credited the Account they service for the Instructed Agent (as an Account Owner). The account held by the Instructed Agent with the Instructing Agent may captured in the dedicated **Settlement Account** element.



Settlement Method code CLRG is not part of CBPR+ specifications but instead used in Market Infrastructure specification (HVPS+)

Group Header > Settlement Information > Settlement Method

pac004 Payment Return– Settlement Account

The pac004 message **Settlement Account** is a nested element as part of **Settlement Information**, this element identifies information related to an account used to settle the payment instruction.

Min 0 – Max 1

The **Settlement Account** identifies the account details maintained at the account servicing institution (Agent responsible for the settlement of the instruction as indicated in the **Settlement Method**)



Min 1 – Max 1 Identification identifies the account maintained at the Debtor Agent (Account Servicing Institution)

Min 0 – Max 1 Type uses the external Cash Account Type code list to identify the type of account

Min 0 – Max 1 Currency identifies the currency of the account

Min 0 – Max 1 Name identifies the name of the account as assigned by the Account Servicing Institution

Min 0 – Max 1 Proxy captures an alternative identification of the account number such as an email address. This element has further nested **Type** which is a choice of external code list or proprietary code and **Identification** which are both mandatory where the Proxy element is used.

Transaction Information



pacs.004 Payment Return - Return Identification

Min 0 – Max 1

The pacs.004 message ***Return Identification*** captures a point-to-point reference used to unambiguously identify the Payment Return message, created by the ***Instructing Agent*** in the ***Return Chain***.



The 35 character return identifier could be considered similar to the legacy Sender's Reference (Field 20) of an MT return payment message.

pac004 Payment Return – Original Group Information

Min 0 – Max 1

The pac004 *Payment Return* uses elements in the **Original Group Information** to capture the message identifier and message name of the underlying payment the *Payment Return* relates to. The mandatory **Original Message Identification** contains the point-to-point reference, and the mandatory **Original Message Name Identification** contains the message name of the underlying payment being returned. Optionally the **Original Creation Date Time** can also be captured.

For example:

Original Message Name Identification “pac008.001.xx” confirms the return is of a pac008 Financial Institution to Financial Institution Customer Credit Transfer. Whereas “pac009.001.xx” confirms the return is of a pac009 Financial Institution Credit Transfer.

 Note: the xx in the CBPR+ Usage Guideline represents the message version of the message received for example pac008.001.08

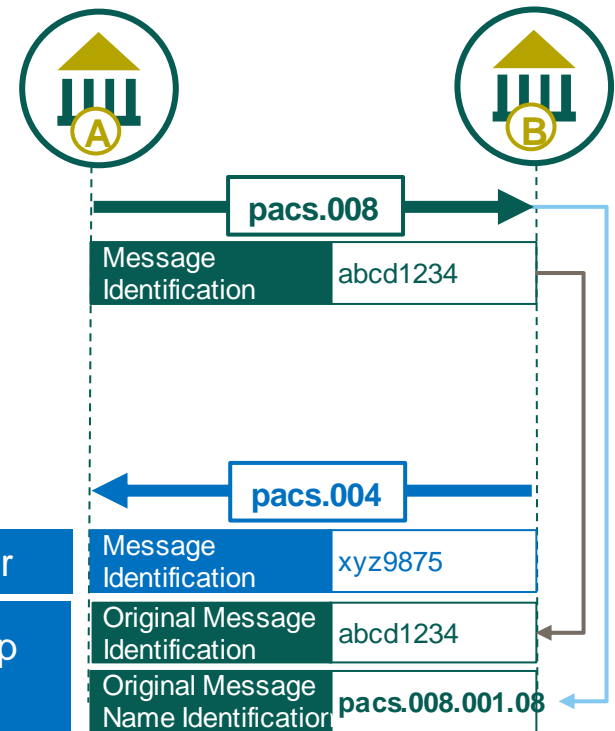

pac.004 Payment Return – Original elements

Min 1 – Max 1

The pac.004 *Payment Return* also uses a number of other **Original** elements in the **Transaction Information** to capture information from the underlying payment that the *Payment Return* relates to. **Mandatory** element examples of this (in addition to *Original Message identification* and *Original Message Name Identification* described on the previous page) include:

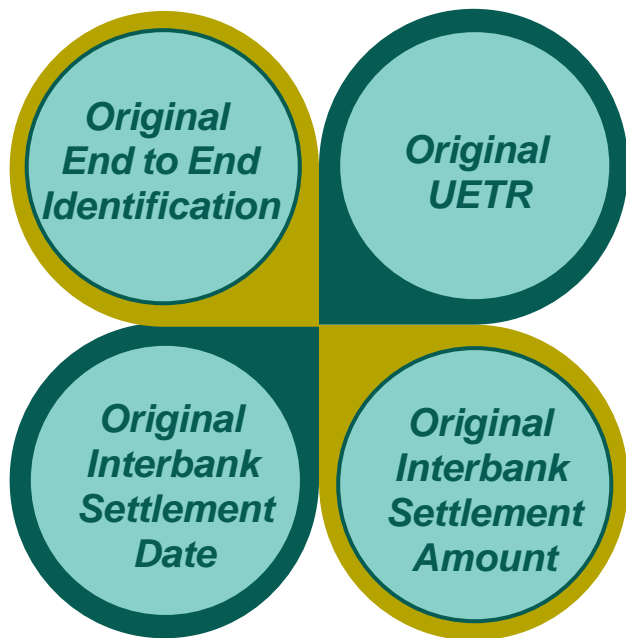

These Original elements enables the **Instructed Agent** in the pac.004 *Payment Return* to re-associate the Return with the payment they originally sent.

Transaction Information

Original End to end Identification

Original UETR

 Original Interbank Settlement Amount

Original Interbank Settlement Date

pac.004 Payment Return – Returned Interbank Settlement Amount and Interbank Settlement Date



The **Returned Interbank Settlement Amount** Min 1 – Max 1 and subsequent **Interbank Settlement Date** Min 1 – Max 1 are mandatory elements in the pac.004 *Payment Return*, these elements are used to capture the currency and amount being returned together with the settlement date of the *Payment Return*.



The **Returned Interbank Settlement Amount** may be a different amount than the **Original Interbank Settlement Amount** (amount received the Agent instructing the *Payment Return*) for example a charge may have been levied for processing the *Payment Return* or the *Payment Return* is a partial amount for overpayment or partial refund
In this case the **Returned Instructed Amount** should be equal to the **Interbank Settlement Amount**, on the first leg of the *Payment Return*. Charge levied should also be captured in the **Charge Information** element.

Transaction Information

Returned Interbank Settlement Amount

Interbank Settlement Date

pac.004 Payment Return – Settlement Priority, Time Indication & Request

The pac.004 message has two optional elements to capture the optional information related to the settlement of the instructions.

Min 0 – Max 1



The **Settlement Priority** provides an optional choice of embedded codes to indicate the instruction's settlement priority from the perspective of the Instructing Agent. This point-to-point information may be used by the Instructed Agent to identify the priority associated with the **Settlement Method** and should not be confused with the **Instruction Priority**.



Note: Where the **Settlement Method** of the pac.004 is 'INDA' (settled performed by the Instructed Agent) this indicates the Settlement Priority. Code 'INGA' implies settlement has already occurred for this point-to-point payment and therefore the Settlement Priority is not necessary.

Min 0 – Max 1



The **Settlement Time Indication** optionally captures the time settlement occurred at a transaction administrator such as a Market Infrastructure.

This DateTime can be captured in two nested elements, **Debit Date Time** and **Credit Date Time**.

pac.004 Payment Return – Returned Instructed Amount and Exchange Rate



Min 0 – Max 1

The **Returned Instructed Amount** captures currency and amount instructed by the **Debtor** in the **Return Chain**. This conditional element is required when the **Returned Interbank Settlement Amount** is not the same currency and/or amount as originally instructed by the **Debtor**. For example a charge is taken or the transactions is converted to another currency.

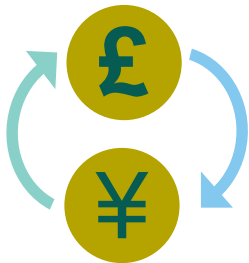

Min 0 – Max 1

The **Exchange Rate** capture the factor (rate) used to convert an amount from one currency into another. This reflects the currency pair price at which one currency was bought with another currency.

pac.004 Payment Return – Charge Bearer

Min 1 – Max 1

The pac.004 **Charge Bearer** element uses an embedded code that is used to specify which party/parties would bear any charges associated with processing the payment transaction. This element is comparable with MT Field 71A ‘Details of Charges’

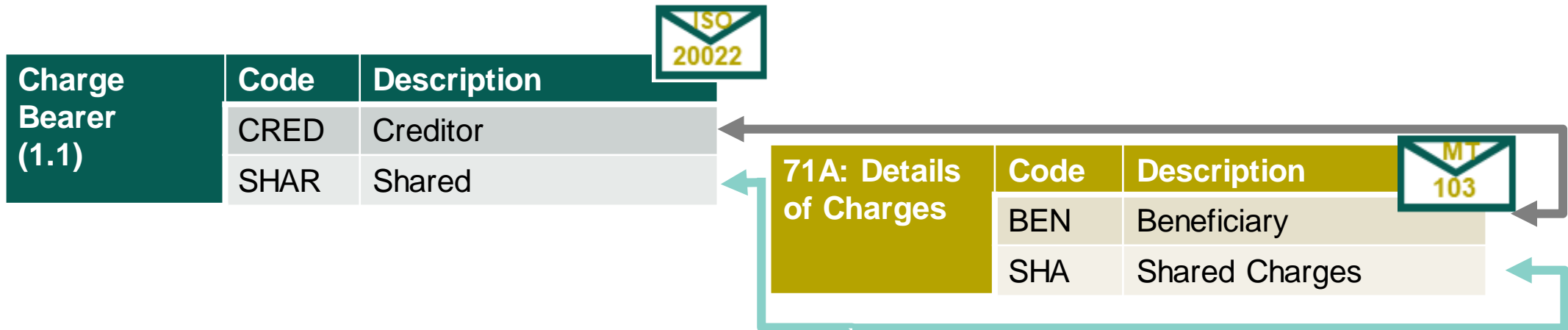

Note: *Charge Bearer* code DEBT (implying the **Return Chain, Debtor** will bear any charges) is removed from the CBPR+ pac.004. Should a non-CBPR+ Payment Return be received with Charge Bearer DEBT, it is recommended to use SHAR in any onward processed Payment Return.

pac004 Payment Return – Charge Information

Min 0 – Max *

The **Charges Information** element provides information on the return charges to be paid by the **Charge Bearer**. This element is comparable with MT Fields: 71F ‘Senders Charges’ and 71G ‘Receiver’s Charges’, although pre-paid charges (legacy 71G ‘Receiver’s Charges’ are an unlikely use case for Payment Returns

Min 0 – Max 1

Charge Information (0.*)	Amount	
	Currency	
	Agent	BICFI
		Name
Structured Postal Address		

In addition to the legacy MT message the pac004 *Charge Information* mandate the *Agent*, this represent the Agent who has taken a charge (deduct from the transaction) CBPR+ best practice recommends the use of the structured Agent BIC.

As the **Charges Information** element is repetitive it can capture charges related to previous legs of the Payment Return transaction chain.



Note: *Charge Information* element is required where a charge is taken on the Payment Return. A charge for returning an incomplete payment by the originator of the Payment Return (Return Chain Debtor) is common practice. It is encouraged that Agents who processed the original payment transaction consider the total operation cost when defining their payment cost recovery model. Whereby further charges on Return Payments should be avoided.

Transaction Information > Charge Information

pac004 Payment Return - Instructed and Instructing Agents

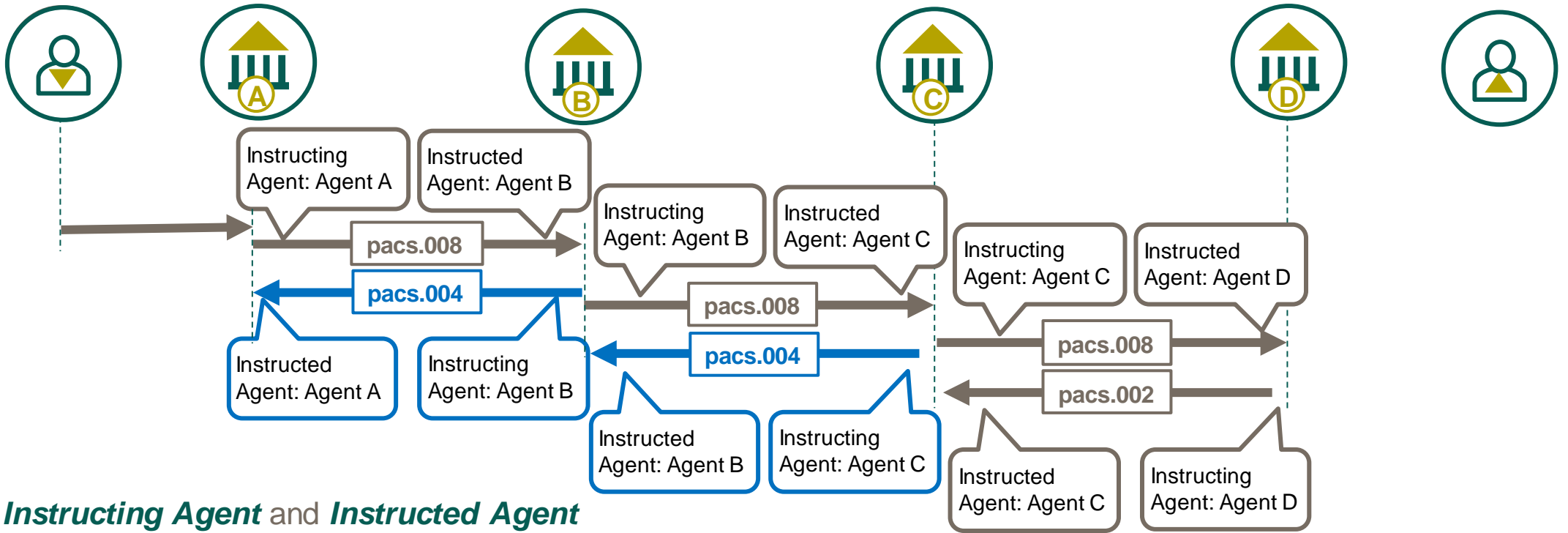

Instructing Agent and **Instructed Agent** represent the Agents involved in the pacs point-to-point message exchange. These roles therefore change on each payment leg.

Transaction Information

Instructing Agent

Instructed Agent



pacs.004 Payment Return – Returned Chain

Min 1 – Max 1

The mandatory **Return Chain** element captures all the parties involved in the return transaction, in much the same way the underlying payment message captures all the parties involved in a payment.

In this element the **role** of the various parties **change**, to reflect the fact the payment is now a *Payment Return*, for example, the *Creditor Agent* of the underlying payment may become the *Debtor Agent* of the *Payment Return*.

Although Ultimate Debtor and Ultimate Creditor are present in the Return chain it is extremely unlikely one of these Parties would be involved in the return chain and can only do so if present as an Ultimate Party in the original payment.

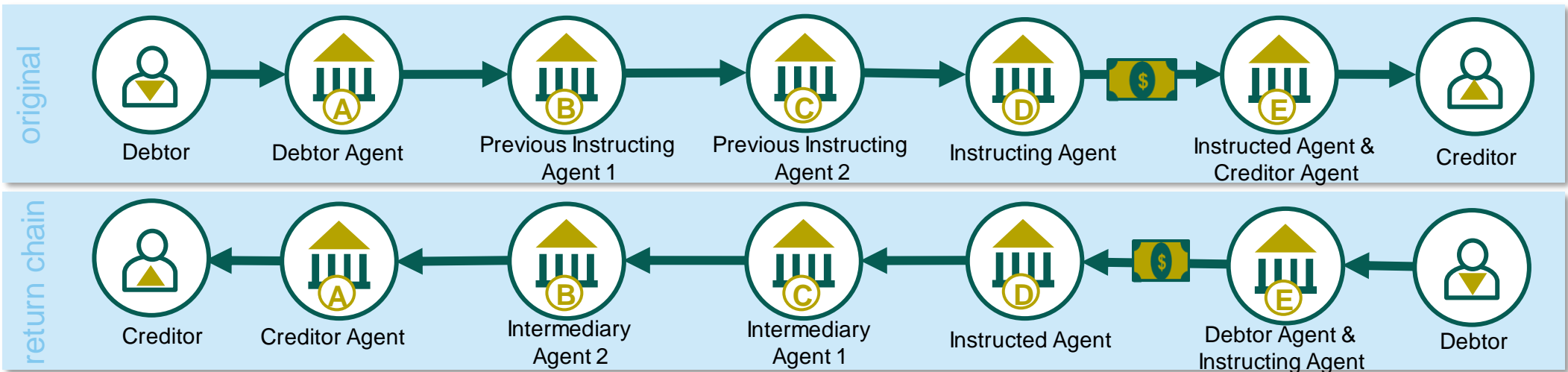

Note: the static Previous Instructing Agent roles in the original payment transition to Intermediary Agent roles in the return chain.

Account for parties in the return chain are not enable in version 9 of the pacs.004 therefore any Return Chain account TextualRules can be ignored

pacs.004 Payment Return – Returned Chain (continued)

Arguably the most common example of a Payment Return is where it is initiated by the Creditor Agent of the original payment, this Agent's role then becomes the mandatory Debtor in the **Return Chain** element (as they owe the money to the party the return is intended for).

Recognising that the original Creditor is not party to the return, for example, they might be a known customer of the original Creditor Agent whereby a reject or return code 'AC01' may be used. In this way the original Creditor was not involved in the Payment Return.

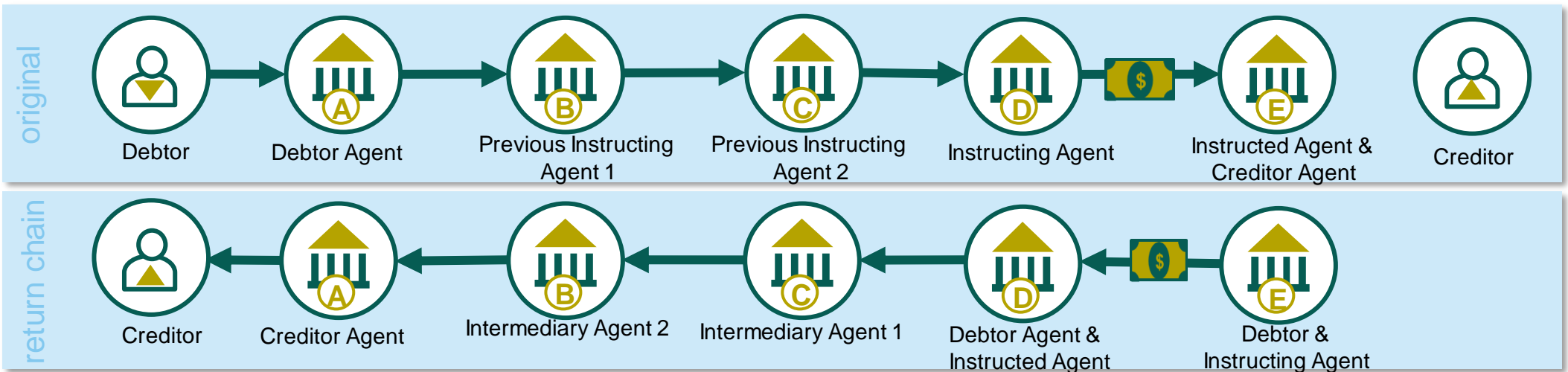

 Note: the static Previous Instructing Agent roles in the original payment transition to Intermediary Agent roles in the return chain

pacs.004 Payment Return – Returned Chain (continued)

Various other Payment Return use cases exist where the common principal is the initiator of the Payment Return becomes the mandatory Debtor in the **Return Chain** element (as they owe the money to the party the return is intended for). And the mandatory Creditor in the **Return Chain** element is the party the payment is being returned to.

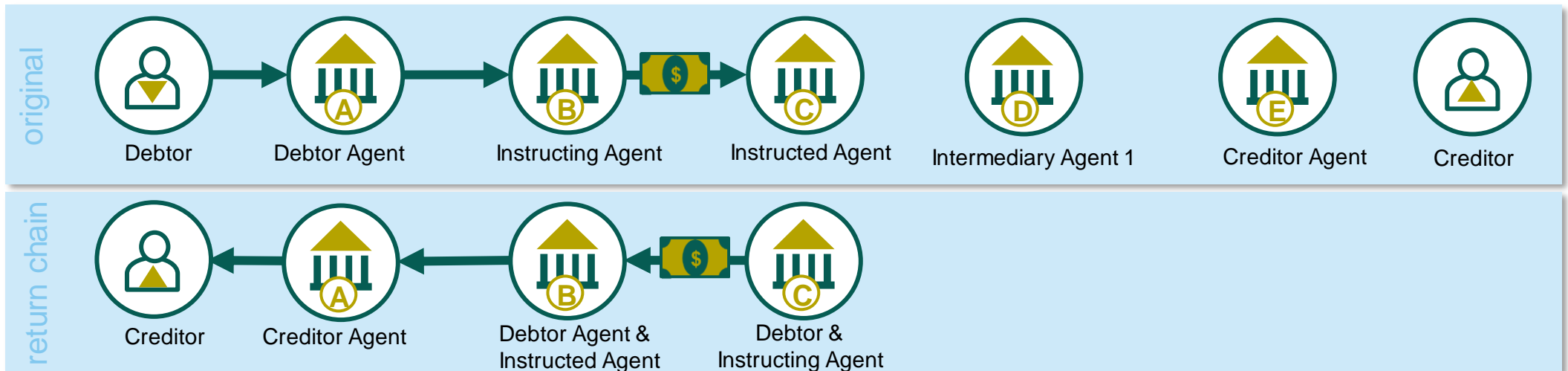

 Note: a party Rejecting the payment using a pacs.002 would not be considered to be involved in the Payment Return as they would not owe money to the party the return is intended for.

paces.004 Payment Return – Return Reason Information

Min 1 – Max 1

The **Return Reason Information** element captures detailed information on the return reason. Within this element:



- the **Originator** element helps identify the party who initiated the request to return the payment. This party would have been included in the underlying payment and may also be included the pacs.004 *Return Chain*.
- the **Reason** is mandatory and is represented by an externalised **Code** choice (↔)
- the **Additional Information** element may also be included to provide further details on the reason for return.

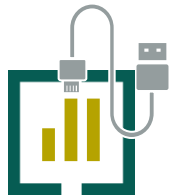

The code list representing the *Return Reason* is part of the ISO 20022 external code list



[Take me to the external code list section](#)

Transaction Information > Return Reason Information

> Originator

↔ Reason

Additional Information

paces.004 Payment Return - Return Reason Codes

Code	Name	ISO Definition	High Level Use Case
AC01	IncorrectAccountNumber	Format of the account number specified is not correct or Account number is missing	Sent by any Agent when a settlement account number is incorrect
AC02	InvalidDebtorAccountNumber	Debtor account number invalid or missing	Sent by any Agent when Debtor account number is incomplete
AC04	ClosedAccountNumber	Account number specified has been closed on the bank of account's books	Sent by Creditor Agent when the Creditor account number is closed
AC06	BlockedAccount	Account specified is blocked, prohibiting posting of transactions against it.	Sent by Creditor Agent when Creditor account is blocked from posting credit entries. Sent by any Agent when a settlement account is blocked
AC07	ClosedCreditorAccountNumber	Creditor account number closed	Sent by Creditor Agent when account number is closed. <i>CBPRplus recommend using AC04, but support AC07 to remain interoperable with other clearing systems.</i>
AC13	InvalidDebtorAccountType	Debtor account type is missing or invalid	Sent by any Agent when Debtor account type element is incorrect
AGNT	IncorrectAgent	Agent in the payment workflow is incorrect	Sent by any Agent when an agent in the payment transaction has an incorrect identification element
AG01	TransactionForbidden	Transaction forbidden on this type of account (formerly NoAgreement)	Sent by any Agent when the type of payment transaction is not allowed for the specified account
AG07	UnsuccessfulDirectDebit	Debtor account cannot be debited for a generic reason. Code value may be used in general purposes and as a replacement for AM04 if debtor bank does not reveal its customer's insufficient funds for privacy reasons	Sent by Debtor Agent of a Direct Debit message, when debtor account can not be debited.
AM02	NotAllowedAmount	Specific transaction/message amount is greater than allowed maximum	Sent by any Agent when payment amount is above an allowed amount. For example the clearing system with a upper amount threshold.

paces.004 Payment Return - Return Reason Codes

Code	Name	ISO Definition	High Level Use Case
AM03	NotAllowedCurrency	Specified message amount is a non processable currency outside of existing agreement	Sent by any Agent when the currency of the payment is not allowed within the existing business agreement
AM04	InsufficientFunds	Amount of funds available to cover specified message amount is insufficient.	Sent by any Agent when there is not sufficient funds to settle the payment transaction.
AM05	Duplication	Payment is a duplicate of another payment	Sent by any Agent when the payment is a duplicate. <i>CBPRplus recommend using DUPL, but support AM05 to remain interoperable with other clearing systems.</i>
AM06	TooLowAmount	Specified transaction amount is less than agreed minimum.	Sent by any Agent when the payment amount is below a minimum amount.
AM07	BlockedAmount	Amount specified in message has been blocked by regulatory authorities	Sent by any Agent when the payment amount is blocked by regulators
AM09	WrongAmount	Amount received is not the amount agreed or expected	Sent by any Agent when the payment amount is incorrect
BE01	InconsistenWithEndCustomer	Identification of end customer is not consistent with associated account number (formerly CreditorConsistency).	Sent by Creditor Agent when there is an inconsistency between the Creditor's identification and the account number
BE04	MissingCreditorAddress	Specification of creditor's address, which is required for payment, is missing/not correct (formerly IncorrectCreditorAddress).	Sent by any Agent when the Creditor's address is missing Sent by Creditor Agent when the Creditor's address is incorrect
BE05	UnrecognisedInitiatingParty	Party who initiated the message is not recognised by the end customer	Sent by Creditor Agent when the initiating party is unknown to the beneficiary
BE07	MissingDebtorAddress	Specification of debtor's address, which is required for payment, is missing/not correct.	Sent by any Agent when the address of the Debtor is missing or incorrect

paces.004 Payment Return - Return Reason Codes

Code	Name	ISO Definition	High Level Use Case
BE10	InvalidDebtorCountry	Debtor country code is missing or invalid	Sent by any Agent when the country code of the Debtor is missing or incorrect
BE11	InvalidCreditorCountry	Creditor country code is missing or invalid	Sent by any Agent when the country code of the Creditor is missing or incorrect
BE16	InvalidDebtorIdentificationCode	Debtor or Ultimate Debtor identification code missing or invalid	Sent by any Agent when the identification of the Debtor or Ultimate Debtor is missing or incorrect
BE17	InvalidCreditorIdentificationCode	Creditor or Ultimate Creditor identification code missing or invalid	Sent by the any Agent when the identification of the Creditor or Ultimate Creditor is missing or incorrect
CN01	AuthorisationCancelled	Authorisation is cancelled.	Sent by any Agent when a third party debit authorisation has been cancelled or is not in place.
CNOR	Creditor bank is not registered	Creditor bank is not registered under this BIC in the Clearing Settlement Mechanism (CSM)	Sent by any Agent when the Creditor Agent is not reachable in the Market Infrastructure (CSM) and an appropriate correspondent can not be determined.
CURR	IncorrectCurrency	Currency of the payment is incorrect	Sent by the Creditor Agent when the Interbank Settlement Amount Currency is not the same as the Creditor account currency and a currency conversion is not accepted on the Creditor's account.
CUST	RequestedByCustomer	Cancellation requested by the Debtor	Sent by any Agent upon request by Debtor. <i>CBPRplus recommend using FOCR, but support CUST to remain interoperable with other clearing systems.</i>
DT01	InvalidDate	Invalid date (eg, wrong or missing settlement date)	Sent by any Agent when the settlement date is in the past and an agreement is in place to reject rather than apply the next possible value date.
DT04	FutureDateNotSupported	Future date not supported	Sent by any Agent when a future settlement date is not supported or appear to be an error e.g. is the wrong year.

paces.004 Payment Return - Return Reason Codes

Definitions and High Level Use Cases

Code	Name	ISO Definition	High Level Use Case
DUPL	DuplicatePayment	Payment is a duplicate of another payment	Sent by any Agent when the payment is a duplicate
ERIN	ERIOptionNotSupported	The Extended Remittance Information (ERI) option is not supported.	Sent by any Agent when extended Remittance information (Related Remittance Information) is not supported or bilaterally/multilaterally agreed
ED05	SettlementFailed	Settlement of the transaction has failed.	Sent by any Agent when the settlement of payment has failed or been unsuccessful.
FF03	InvalidPaymentTypeInformation	Payment Type Information is missing or invalid. Generic usage if cannot specify Service Level or Local Instrument code	Sent by any Agent when the Payment Type Information (Instruction Priority, Clearing Channel) provided for the payment is incorrect or not supported.
FF04	InvalidServiceLevelCode	Service Level code is missing or invalid	Sent by any Agent when the Payment Type Information Service Level provided for the payment is incorrect or not supported
FF05	InvalidLocalInstrumentCode	Local Instrument code is missing or invalid	Sent by any Agent when the Payment Type Information Local Instrument provided for the payment is incorrect or not supported
FF06	InvalidCategoryPurposeCode	Category Purpose code is missing or invalid	Sent by any Agent when the Payment Type Information Category Purpose provided for the payment is incorrect or not supported
FF07	InvalidPurpose	Purpose is missing or invalid	Sent by any Agent when the Purpose provided for the payment is either missing or incorrect
FOCR	FollowingCancellationRequest	Return following a cancellation request	Sent by any Agent that has accepted a payment cancellation request (camt.056) and subsequently is rejecting the unsettled payment instruction.
FR01	Fraud	Returned as a result of fraud.	Sent by any Agent when the payment is identified as fraudulent.
MD01	NoMandate	No Mandate	Sent by any Agent when a Direct Debit message has no mandate in place.



pac004 Payment Return - Return Reason Codes

Code	Name	ISO Definition	High Level Use Case
MD02	MissingMandatoryInformationInMandate	Mandate related information data required by the scheme is missing.	Sent by any Agent when information required by the clearing scheme is missing.
MD05	CollectionNotDue	Creditor or creditor's agent should not have collected the direct debit	Sent by any Agent when a Direct Debit collection was not due
MD07	EndCustomerDeceased	End customer is deceased.	Sent by Creditor Agent when the Creditor or Ultimate Creditor is deceased
MS02	NotSpecifiedReasonCustomerGenerated	Reason has not been specified by end customer	Sent by Creditor Agent where instructed to reject by the Creditor, but no reason was specified
MS03	NotSpecifiedReasonAgentGenerated	Reason has not been specified by agent.	Sent by any Agent but no reason is specified
NARR	Narrative	Reason is provided as narrative information in the additional reason information.	Sent by any Agent the reason is provided as narrative information. Only to be used where no other code is appropriate! (i.e. exceptional circumstances)
NOAS	NoAnswerFromCustomer	No response from Beneficiary	Sent by any Agent when the Creditor did not respond to query for additional information in order that the payment could be credited e.g. currency control documentation.
NOCM	Not compliant (more generic)	Customer account is not compliant with regulatory requirements, for example FICA (in South Africa) or any other regulatory requirements which render an account inactive for certain processing.	Sent by any Agent when the Creditor account is not compliant with certain regulatory requirements.
RC01	BankIdentifierIncorrect	Bank Identifier code specified in the message has an incorrect format (formerly IncorrectFormatForRoutingCode).	Sent by any Agent when an incorrect BIC has been used in the payment
RC03	InvalidDebtorBankIdentifier	Debtor bank identifier is invalid or missing	Sent by any Agent when the Debtor Agent identification is incorrect or missing

paces.004 Payment Return - Return Reason Codes

Definitions and High Level Use Cases

Code	Name	ISO Definition	High Level Use Case
RC04	InvalidCreditorBankIdentifier	Creditor bank identifier is invalid or missing	Sent by any Agent when the Creditor Agent identification is incorrect or missing
RC08	InvalidClearingSystemMemberIdentifier	ClearingSystemMemberIdentifier is invalid or missing. Generic usage if cannot specify between debit or credit account	Sent by any Agent when the clearing system member identification for an Agent is incorrect
RC11	InvalidIntermediaryAgent	Intermediary Agent is invalid or missing	Sent by any Agent when the intermediary agent identification is incorrect
RF01	NotUniqueTransactionReference	Transaction reference is not unique within the message.	Sent by any Agent when the transaction reference (UETR and Instruction Identification) are not unique
RR01	Missing Debtor Account or Identification	Specification of the debtor's account or unique identification needed for reasons of regulatory requirements is insufficient or missing	Sent by any Agent when the Debtor identification or debtor account is missing, or the information provided are not sufficient
RR02	Missing Debtor Name or Address	Specification of the debtor's name and/or address needed for regulatory requirements is insufficient or missing.	Sent by any Agent since the Debtor name or Address is missing, or information provided is not sufficient
RR03	Missing Creditor Name or Address	Specification of the creditor's name and/or address needed for regulatory requirements is insufficient or missing.	Sent by any Agent since the Creditor name or Address is missing, or information provided is not sufficient
RR04	Regulatory Reason	Regulatory Reason	Sent by any Agent due to any unspecified regulatory reason
RR05	RegulatoryInformationInvalid	Regulatory or Central Bank Reporting information missing, incomplete or invalid.	Sent by any Agent when the reporting information required by the central bank or reporting authority is missing or not complete
RR06	TaxInformationInvalid	Tax information missing, incomplete or invalid.	Sent by any Agent where required tax information is missing, not valid or not complete



pac004 Payment Return - Return Reason Codes

Code	Name	ISO Definition	High Level Use Case
RR07	RemittanceInformationInvalid	Remittance information structure does not comply with rules for payment type.	Sent by any Agent since the remittance information is incorrect
RR08	RemittanceInformationTruncated	Remittance information truncated to comply with rules for payment type.	Sent by any Agent where the Structured Remittance Information has not been bilaterally or multilaterally agreed, which or has resulted in truncation
RR09	InvalidStructuredCreditorReference	Structured creditor reference invalid or missing.	Sent by any Agent when the structure of the creditor reference in the remittance information is invalid or missing
RR11	InvalidDebtorAgentServiceID	Invalid or missing identification of a bank proprietary service.	Sent by any Agent where the proprietary identification for the Debtor is invalid or not understood
RR12	InvalidPartyID	Invalid or missing identification required within a particular country or payment type.	Sent by any Agent where a proprietary party identification is considered invalid or not understood
RUTA	ReturnUponUnableToApply	Return following investigation request and no remediation possible.	Sent by any Agent that is unsatisfied with the outcome of the unable to apply request and is subsequently rejecting the payment instruction. Alternatively it can be used by the original Creditor Agent when the creditor is unable to apply the transaction
TM01	InvalidCut off time	Associated message, payment information block, or transaction was received after agreed processing cut-off time.	Sent by any Agent when the message was received after the agreed processing cut off time and an agreement is in place to reject rather than apply the next possible value date.
UPAY	UnduePayment	Payment is not justified.	Sent by any Agent the payment is undue

pac004 Payment Return – Original Transaction Reference

Min 0 – Max 1

The **Original Transaction Reference** optionally capture elements related to the original transactions. The inclusion of this element is particularly useful where the *Payment Return* includes an Agent not party to the original transaction, or where a significant time lapse has occurred between the original payment and the *Payment Return* i.e., information may have been archived by Agent in the Return chain. CBPR+ has two rules describing when the Original Transaction Reference should be used.

The *Amount* within the nesting of this Original Transaction Reference element only allows for the *Instructed Amount*, as instructed by the Debtor in the original payment initiation request. If the *Instructed Amount* was present in the original payment, populating this data is simple. However, we should also recognise the *Instructed Amount* is not always present (and in fact is not available in the pac009), whereby this value should represent the amount in the *Interbank Settlement Amount* of the pac message being returned. The use of *Instructed Amount* is best described in the pac008 [Currency and Amount section](#).



Note: the role of Parties and Agent in Original element remain unchanged unlike elements such as the Return chain

Transaction Information > Original Transaction Reference >

Payment Return (pacs.004) – Highlighting key considerations.

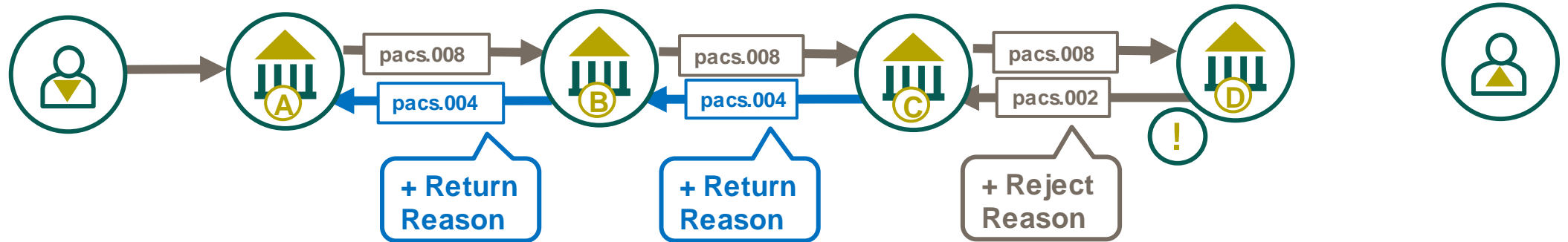

Within the Payment Return (pacs.004)

- the *Original Group Information* element is used to refer to original message for which the return relates to. e.g. based upon the above example pacs.008 as the original message would be included in the pacs.004
- the *Transaction Information > Original UETR* element would include UETR of the payment message received. i.e. the **same UETR is used on the Payment Return.**
- the *Original Transaction Reference* element includes detail from the *Original Message Name Identification* e.g. the *Debtor* of the original pacs.008.001.xx
- the *Return Chain* element includes the parties in the return payment chain, noting the parties reverse (i.e. change role) from the original payment whereby the *Debtor* of the original payment becomes the *Creditor* in the Return Chain.

Index of pacs.004 Use Cases

Use case should be considered as a principal example whereby use case may be cross referenced e.g. a use case involving a Market Infrastructure can apply the Market Infrastructure legs to other use cases.

Serial Customer Payments

Use Case p.4.1.1 – Payment Return (pacs.004) of an incomplete Customer Credit Transfer (pacs.008)

Use Case p.4.1.2 – Payment Return (pacs.004) of a complete Customer Credit Transfer (pacs.008)

Use Case p.4.1.2.a – Partial Payment Return (pacs.004) of a complete Customer Credit Transfer (pacs.008)

Use Case p.4.1.2.b – Refund Payment of a complete Customer Credit Transfer (pacs.008)

Use Case p.4.1.3 - Payment Return (pacs.004) of an incomplete Customer Credit Transfer (pacs.008) involving a Market Infrastructure

Serial Financial Institution Payments

Use Case p.4.2.1 - Payment Return (pacs.004) of an incomplete Financial Institution Credit Transfer (pacs.009)

Use Case p.4.2.2 - Payment Return (pacs.004) of a complete Financial Institution Credit Transfer (pacs.009)

Use Case p.4.2.3 - Payment Return (pacs.004) of an incomplete Financial Institution Credit Transfer (pacs.009) involving a Market Infrastructure

Cover Method Payments

Use Case p.4.3.1.a - Payment Return (pacs.004) of an incomplete payment using the cover method

Use Case p.4.3.1.b - Payment Return (pacs.004) of an incomplete payment using the cover method

Use Case p.4.3.2 - Payment Return (pacs.004) of a complete payment using the cover method

Use Case p.4.3.2.a - Payment Return (pacs.004) of a complete payment using the cover method

Use Case p.4.3.3 - Payment Return (pacs.004) of an incomplete cover payment

Payment Return (pacs.004) of an incomplete Customer Credit Transfer (pacs.008)

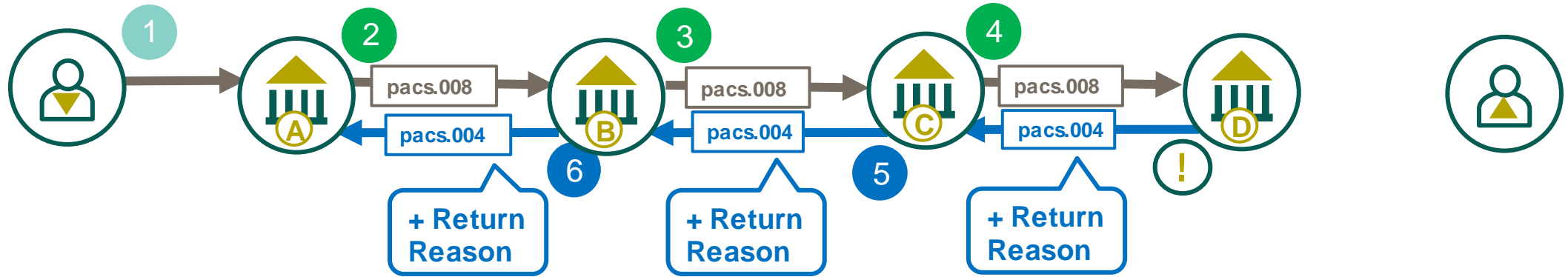

1 Debtor initiates a payment instruction to the Debtor Agent

2 Debtor Agent (A) initiates a serial payment towards the Creditor Agent (D) using Agents B & C as intermediaries

3 Agent B processes the payment on Agent C

4 Agent C processes the payment on Agent D

! Having received the payment Agent D recognises the payment can not be completed as requested e.g. the Creditor's account is closed. Agent D return the payment to Agent C (as the original payment had already settled) together with the return reason.

5 Agent C return funds to Agent B, together with the reason code for return.

6 Agent B return funds to Agent A, together with the reason code for return.

Payment Return (pacs.004) of a complete Customer Credit Transfer (pacs.008)

Use Case p.4.1.2

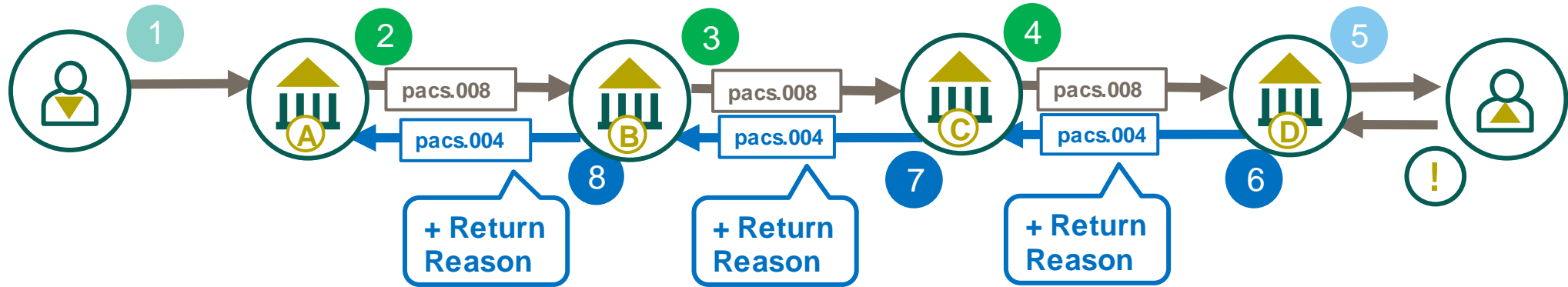

1 Debtor initiates a payment instruction to the Debtor Agent

2 Debtor Agent (A) initiates a serial payment towards the Creditor Agent (D) using Agents B & C as intermediaries

3 Agent B processes the payment on Agent C

4 Agent C processes the payment on Agent D

5 Agent D credits the account of the Creditor, and may optionally provide a notification e.g. credit notification in addition to an account statement (camt.053)

! Creditor determines that they wish to return the payment e.g. they are unable to apply, and instructs their bank (Agent D) to return the payment together with the reason.

6 Agent D returns the payment to Agent C using a Payment Return message (pacs.004) also including the return reason code.

7 Agent C return funds to Agent B, together with the reason code for return.

8 Agent B return funds to Agent A, together with the reason code for return.

Partial Payment Return (pacs.004) of a complete Customer Credit Transfer (pacs.008)

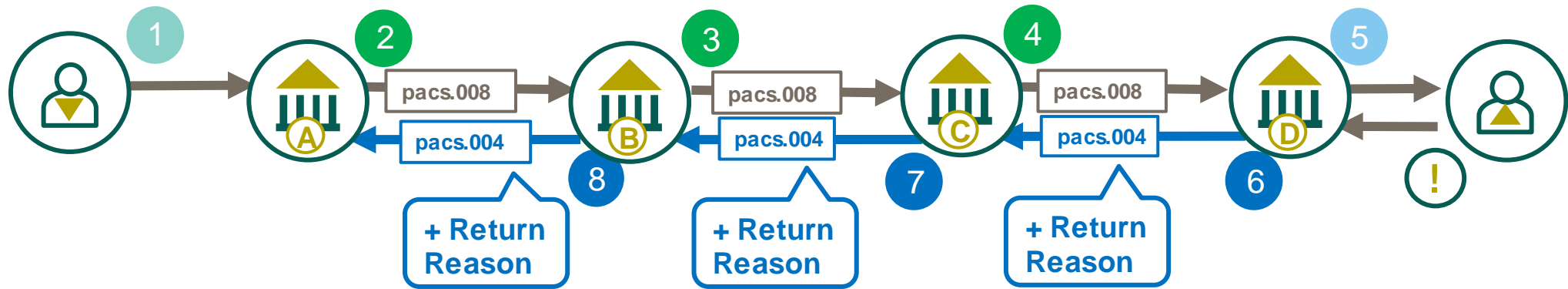

1 Debtor initiates a payment instruction to the Debtor Agent

2 Debtor Agent (A) initiates a serial payment towards the Creditor Agent (D) using Agents B & C as intermediaries

3 Agent B processes the payment on Agent C

4 Agent C processes the payment on Agent D

5 Agent D credits the account of the Creditor, and may optionally provide a notification e.g. credit notification in addition to an account statement (camt.053)

! Creditor determines that they wish to partially return the payment e.g. they were over paid or provide a partial refund, and instructs their bank (Agent D) to partially return the payment together with the reason.

6 Agent D returns the payment to Agent C using a Payment Return message (pacs.004) also including the return reason code.

7 Agent C return funds to Agent B, together with the reason code for return.

8 Agent B return funds to Agent A, together with the reason code for return.

Refund Payment of a complete Customer Credit Transfer (pacs.008)

Use Case p.4.1.2.b

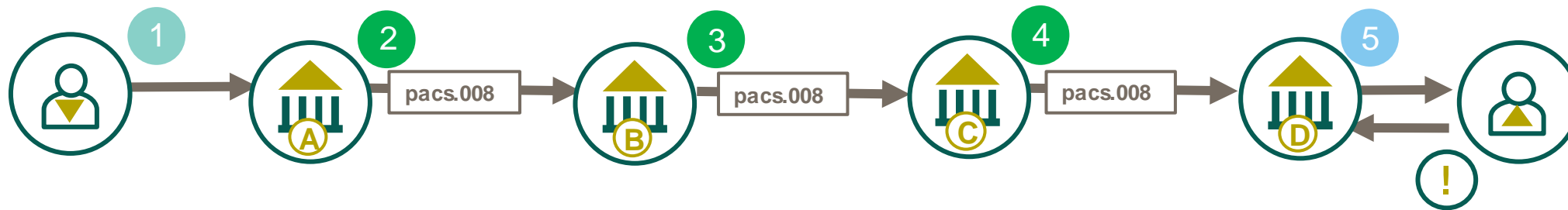

1

Debtor initiates a payment instruction to the Debtor Agent

2

Debtor Agent (A) initiates a serial payment towards the Creditor Agent (D) using Agents B & C as intermediaries

3

Agent B processes the payment on Agent C

4

Agent C processes the payment on Agent D

5

Agent D credits the account of the Creditor, and may optionally provide a notification e.g. credit notification in addition to an account statement (camt.053)

!

Creditor determines that they wish to refund the payment e.g. they could not provide the goods or services paid for. They instruct a new payment from their bank account.

In some circumstances the Creditor may take it upon themselves to provide a refund, using a new payment. Equally the period the original payment is store prior to data archive, particularly by the Creditor Agent, is not indefinite. Whereby a new payment may be used as a refund. Due to the nature of this refund not being identified as a Payment Return, reversal indicatory in the statement entry and reason codes describing the nature of the refund are unlikely.



Payment Return (pacs.004) of an incomplete Customer Credit Transfer (pacs.008) involving a Market Infrastructure

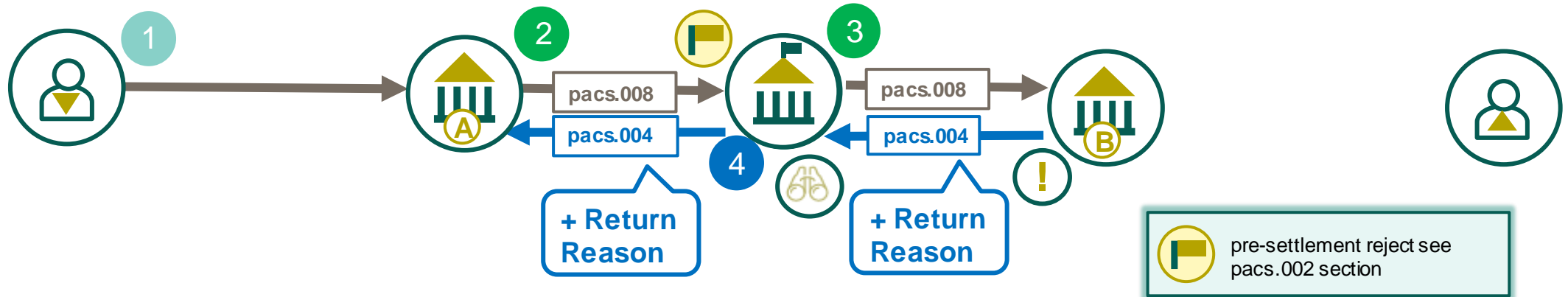

1 Debtor initiates a payment instruction to the Debtor Agent

2 Debtor Agent (A) initiates a serial payment towards the Creditor Agent (B) using the local currency ISO 2022 Market Infrastructure

3 The payment is **settled** via the local ISO 2022 Market Infrastructure, whereby the payment is forwarded to the Creditor Agent (B)

! Having received the payment Agent B recognises the payment can not be completed as requested e.g. the Creditor's account is closed. Agent B returns the payment to Agent A using a Payment Return message (pacs.004) also including the return reason code.

4 The Market Infrastructure returns the payment performing the necessary settlement posting between Agent B and Agent A.

pre-settlement reject see pacs.002 section

Payment Return (pacs.004) of an incomplete Financial Institution Credit Transfer (pacs.009)

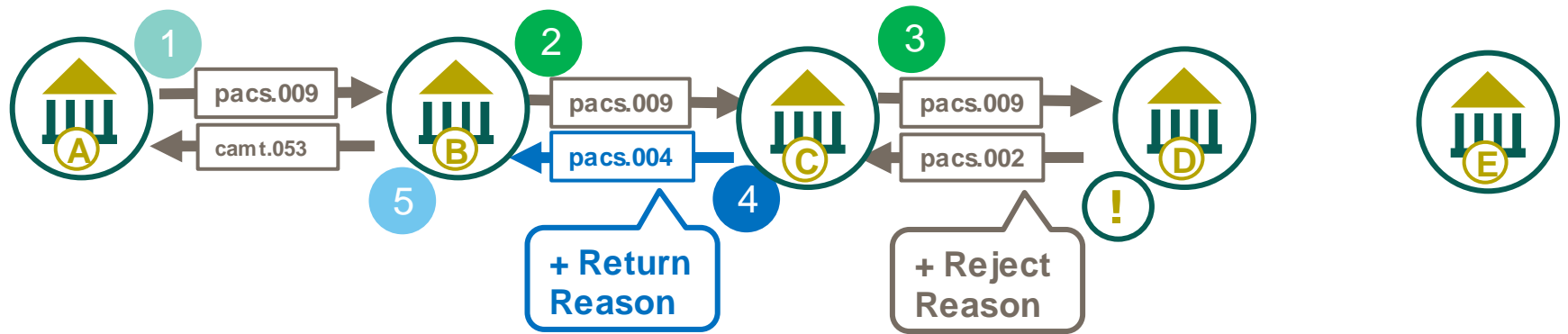

1 Agent A as the Debtor initiates a payment instruction to the Debtor Agent (Agent B)

3 Agent C processes the payment onto Agent D

! Having received the payment instruction Agent D recognises the payment can not be completed as requested e.g. the Creditor's account is closed. Agent D rejects the payment to Agent C using a Status Information message (pacs.002) also including the return reject code.

4 Agent C return funds to Agent B, together with the reason code for return.

2 Debtor Agent (B) debits the account of Agent A and initiates a serial payment towards the Creditor (Agent E) using Agents C as an intermediary.

5 Agent B advises Agent A of the return of payment together with the reason using the camt.053 and may optionally provide a notification e.g. credit notification.

Payment Return (pacs.004) of a complete Financial Institution Credit Transfer (pacs.009)

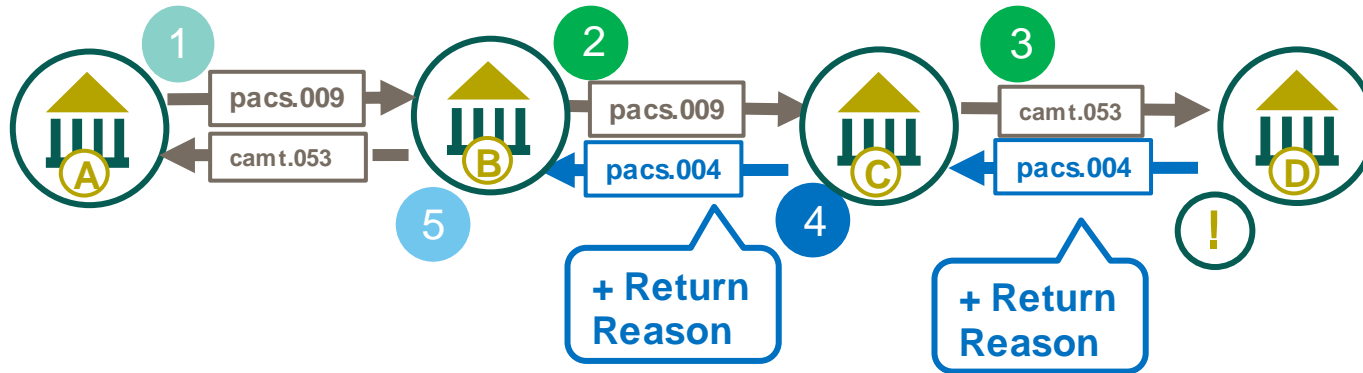

1 Agent A as the Debtor initiates a payment instruction to the Debtor Agent (Agent B)

2 Debtor Agent (B) debits the account of Agent A and initiates a serial payment towards the Creditor (Agent D) using Agents C as an intermediary.

3 Creditor Agent (C) credits the account of Agent D and may optionally provide a notification e.g. credit notification, in addition to an account statement (camt.053)

! Having received the payment Agent D recognises the payment is incorrect e.g. the wrong amount was received . Agent D sends a Payment Return to Agent C including the return reason.

4 Agent C return funds to Agent B, together with the reason code for return.

5 Agent B advises Agent A of the return of payment together with the reason using the camt.053 and may optionally provide a notification e.g. credit notification.

Payment Return (pacs.004) of an incomplete Financial Institution Credit Transfer (pacs.009) involving a Market Infrastructure

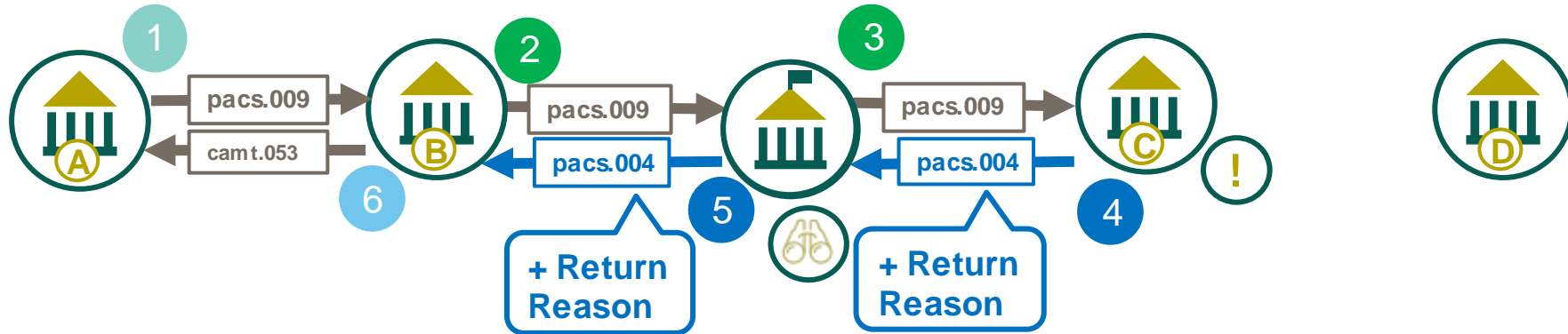

1 Agent A as the Debtor initiates a payment instruction to the Debtor Agent (Agent B)

2 Debtor Agent (B) debits the account of Agent A and initiates a serial payment towards the Creditor (Agent D) using the local currency ISO 2022 Market Infrastructure.

3 The payment is settled via the local ISO 2022 Market Infrastructure, whereby the payment is forwarded to the Creditor Agent (C)

! Having received the payment Agent C recognises the payment can not be completed as requested e.g. the Creditor's account is closed. Agent C returns the payment towards Agent B using a Payment Return message (pacs.004) also including the return reason code.

4 Agent C returns the payment to Agent B, together with the reason code for return via the local currency ISO 2022 Market Infrastructure.

5 The payment return is settled via the local ISO 2022 Market Infrastructure, whereby the payment return is forwarded to the Creditor Agent (B)

6 Agent B advises Agent A of the return of payment together with the reason using the camt.053 and may optionally provide a notification e.g. credit notification.



Market Infrastructure will either conform to HVPS+ guidelines or establish their own usage guidelines based on the ISO 2022 standard. 420

Payment Return (pacs.004) of an incomplete payment using the cover method

Use Case p.4.3.1.a

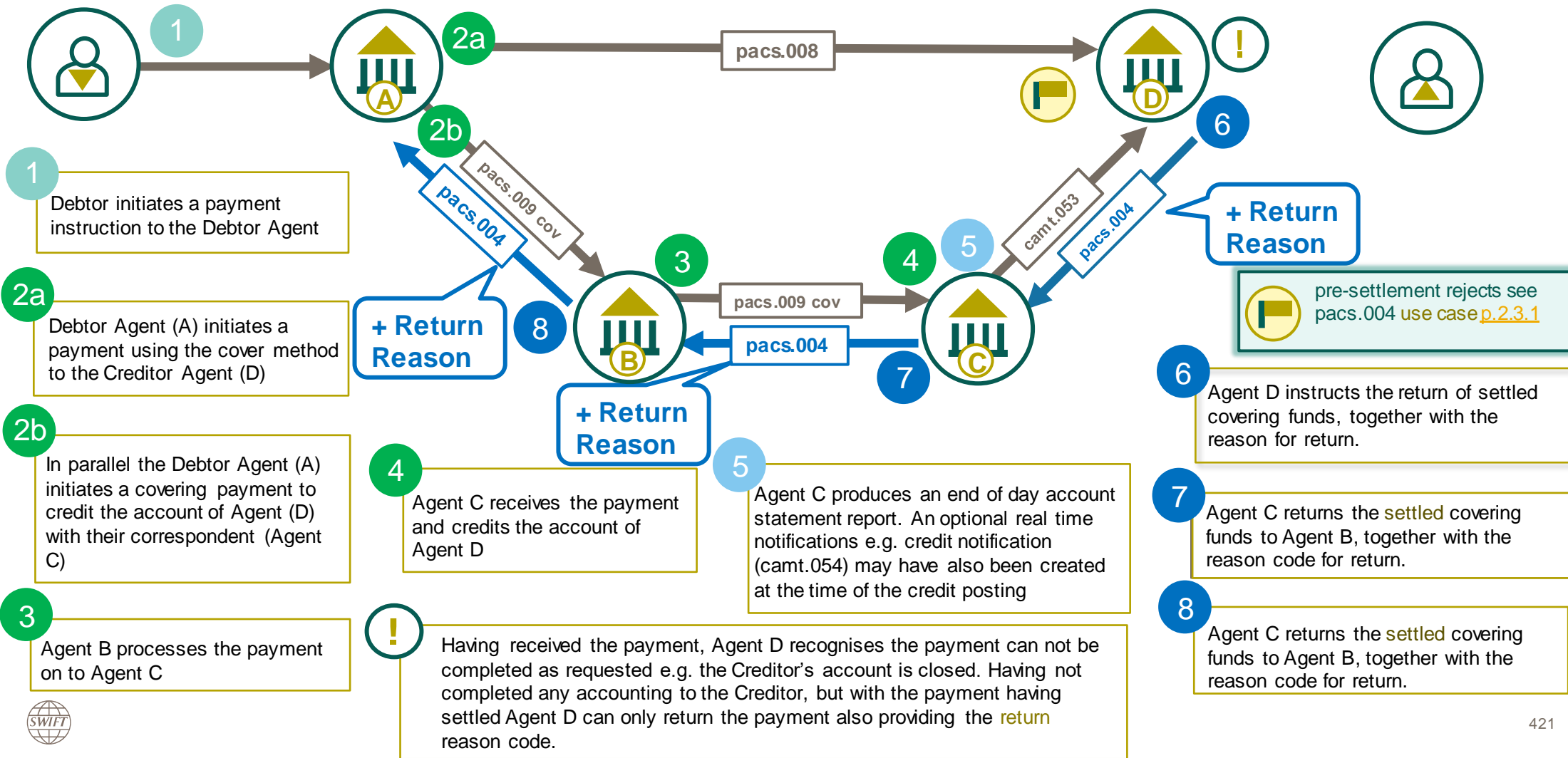

Payment Return (pacs.004) of an incomplete payment using the cover method

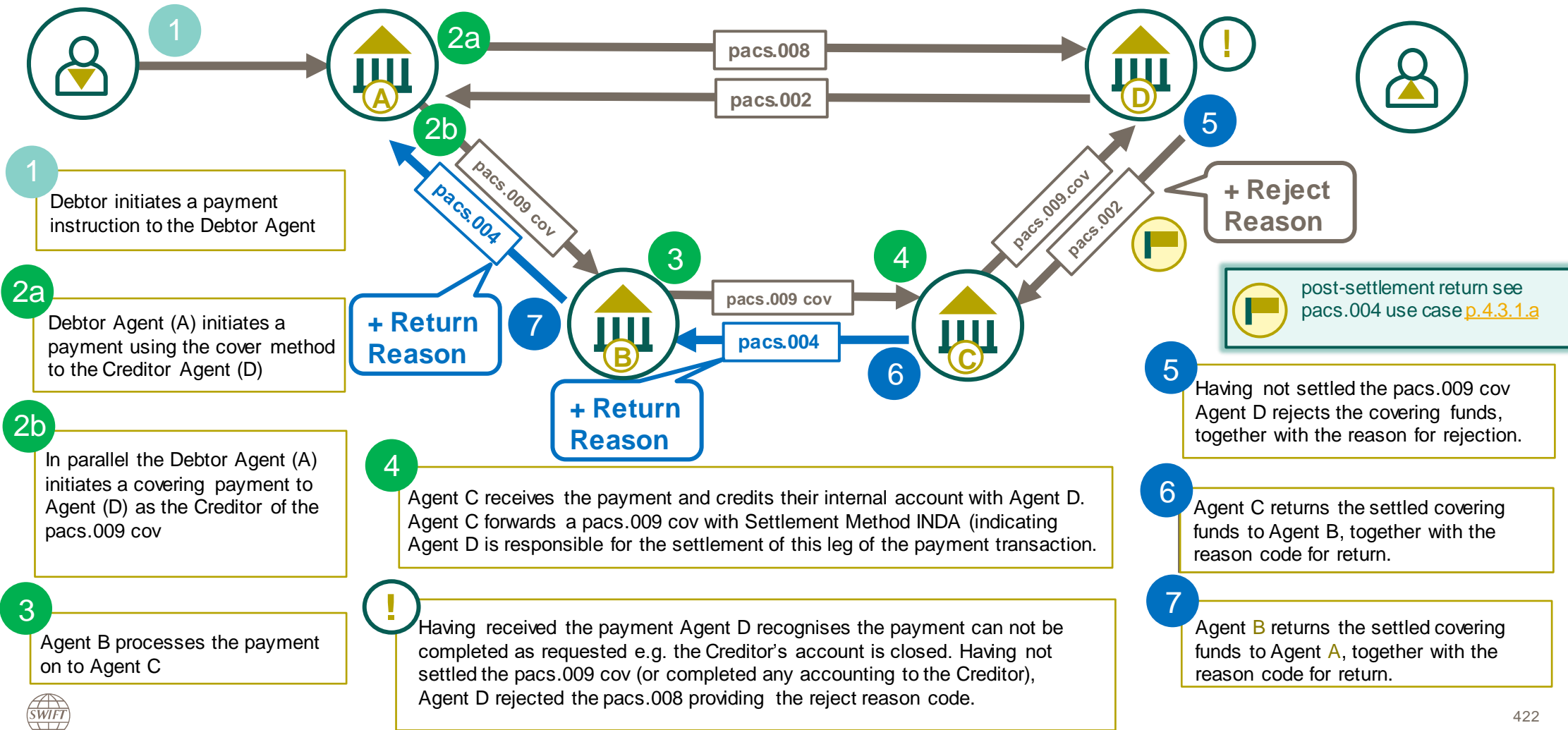

Payment Return (pacs.004) of a complete payment using the cover method

Use Case p.4.3.2

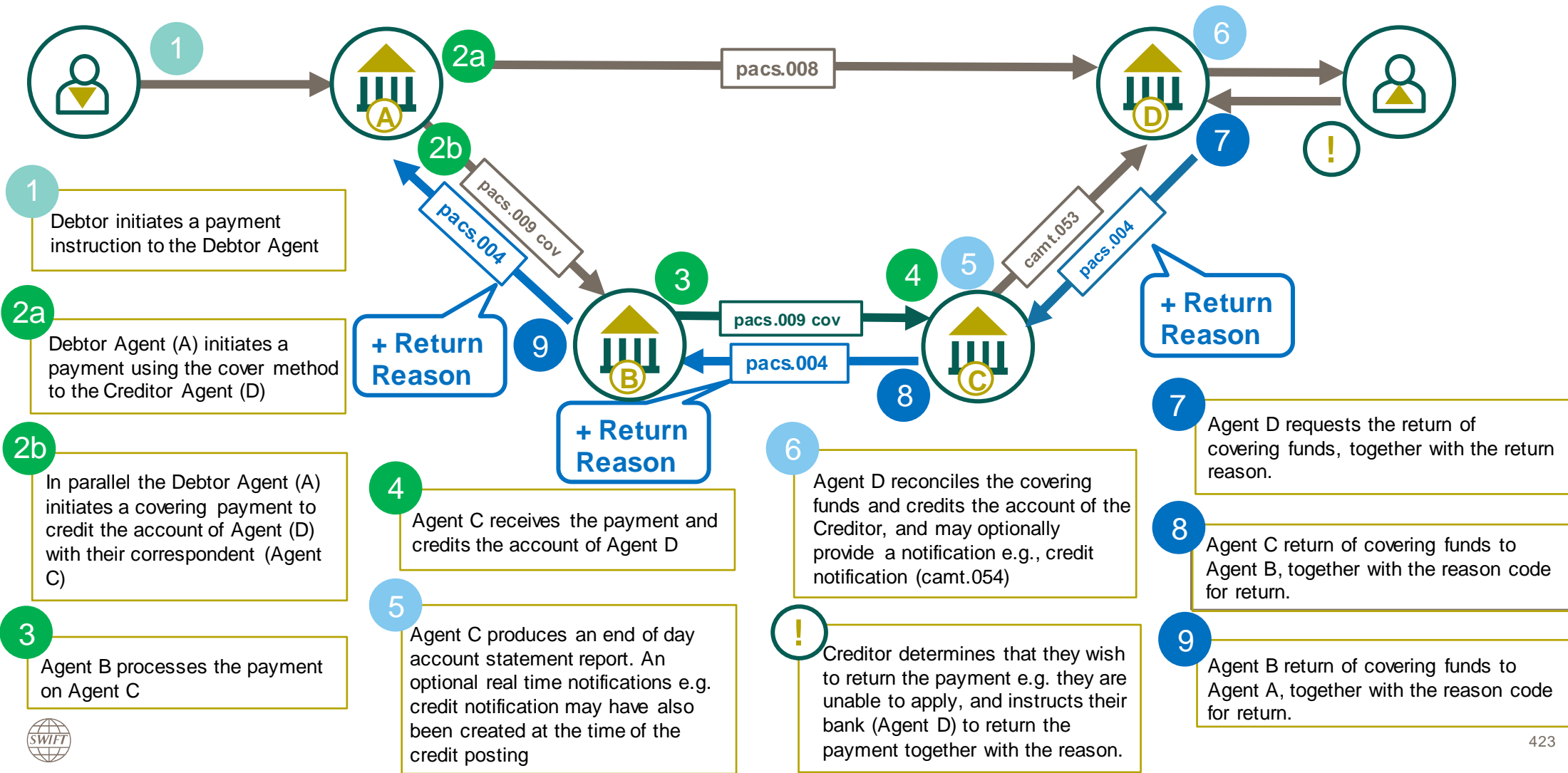

1 Debtor initiates a payment instruction to the Debtor Agent

2a Debtor Agent (A) initiates a payment using the cover method to the Creditor Agent (D)

2b In parallel the Debtor Agent (A) initiates a covering payment to credit the account of Agent (D) with their correspondent (Agent C)

3 Agent B processes the payment on Agent C

+ Return Reason

+ Return Reason

+ Return Reason

4 Agent C receives the payment and credits the account of Agent D

5 Agent C produces an end of day account statement report. An optional real time notifications e.g. credit notification may have also been created at the time of the credit posting

6 Agent D reconciles the covering funds and credits the account of the Creditor, and may optionally provide a notification e.g., credit notification (camt.054)

! Creditor determines that they wish to return the payment e.g. they are unable to apply, and instructs their bank (Agent D) to return the payment together with the reason.

7 Agent D requests the return of covering funds, together with the return reason.

8 Agent C return of covering funds to Agent B, together with the reason code for return.

9 Agent B return of covering funds to Agent A, together with the reason code for return.



Payment Return (pacs.004) of a complete payment using the cover method

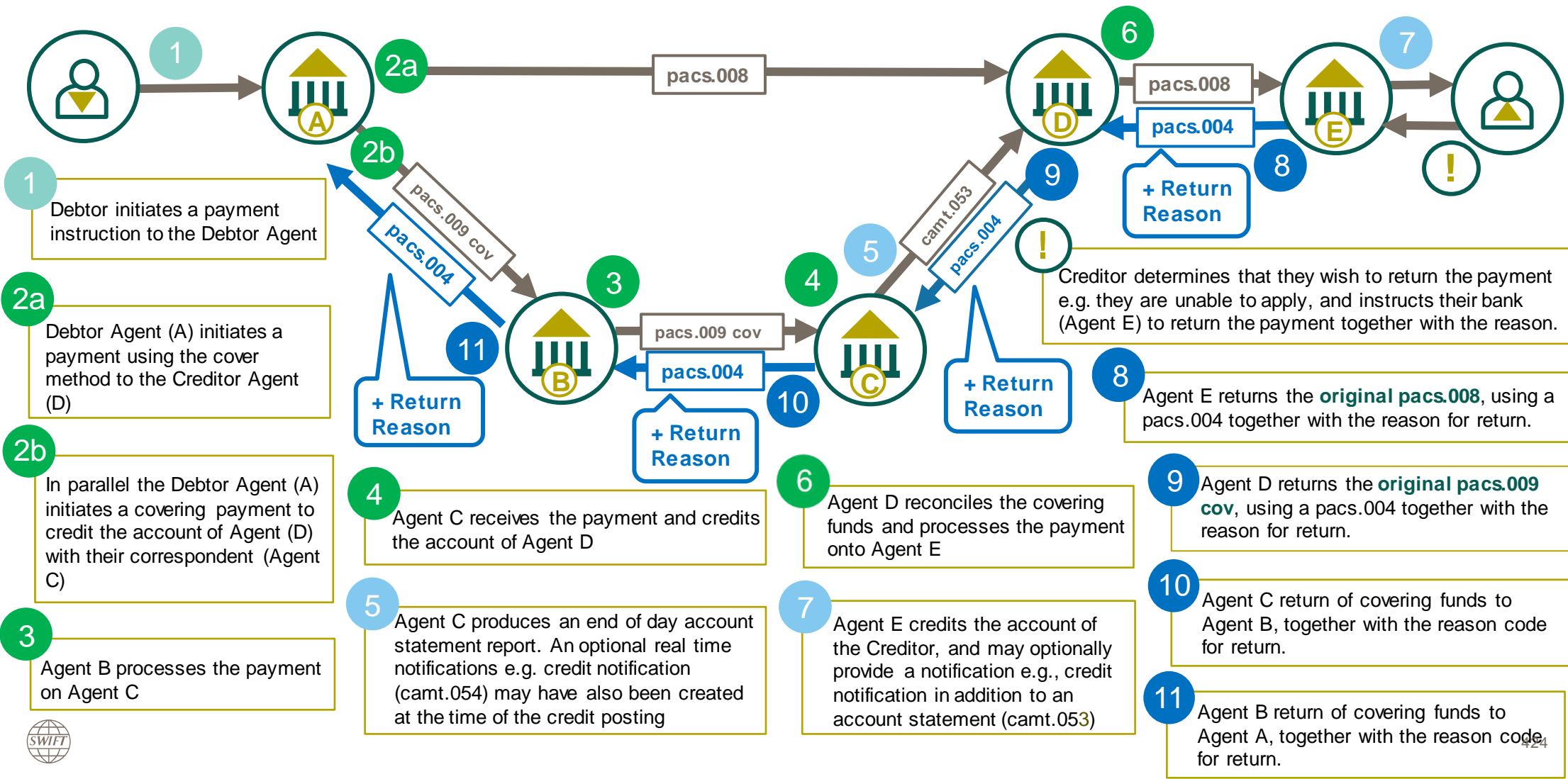

1 Debtor initiates a payment instruction to the Debtor Agent

2a Debtor Agent (A) initiates a payment using the cover method to the Creditor Agent (D)

2b In parallel the Debtor Agent (A) initiates a covering payment to credit the account of Agent (D) with their correspondent (Agent C)

3 Agent B processes the payment on Agent C

4 Agent C receives the payment and credits the account of Agent D

5 Agent C produces an end of day account statement report. An optional real time notifications e.g. credit notification (camt.054) may have also been created at the time of the credit posting

6 Agent D reconciles the covering funds and processes the payment onto Agent E

7 Agent E credits the account of the Creditor, and may optionally provide a notification e.g., credit notification in addition to an account statement (camt.053)

Creditor determines that they wish to return the payment e.g. they are unable to apply, and instructs their bank (Agent E) to return the payment together with the reason.

8 Agent E returns the **original pacs.008**, using a pacs.004 together with the reason for return.

9 Agent D returns the **original pacs.009 cov**, using a pacs.004 together with the reason for return.

10 Agent C return of covering funds to Agent B, together with the reason code for return.

11 Agent B return of covering funds to Agent A, together with the reason code for return.



Payment Return (pacs.004) of an incomplete cover payment

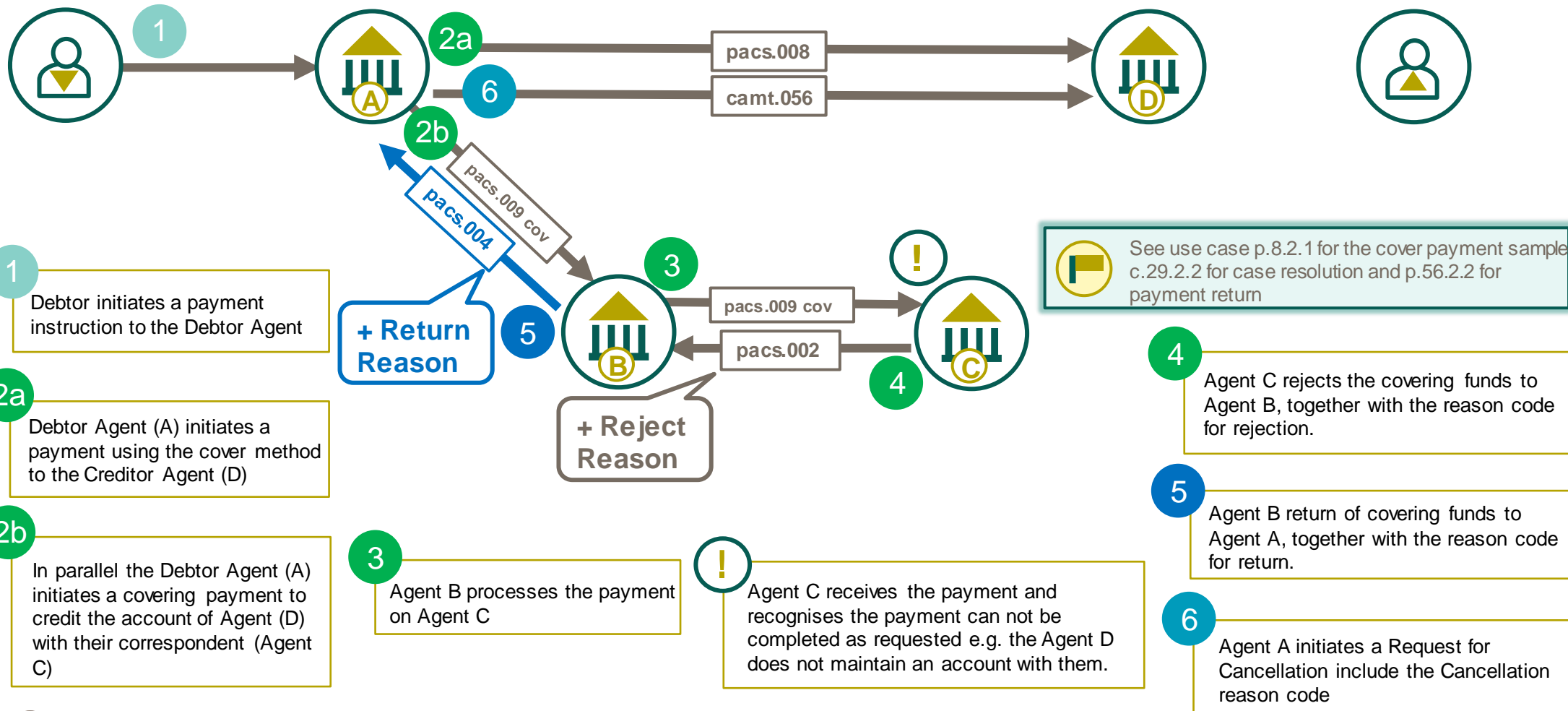

pacs.010

Financial Institution Direct Debit



pac010 Financial Institution Direct Debit

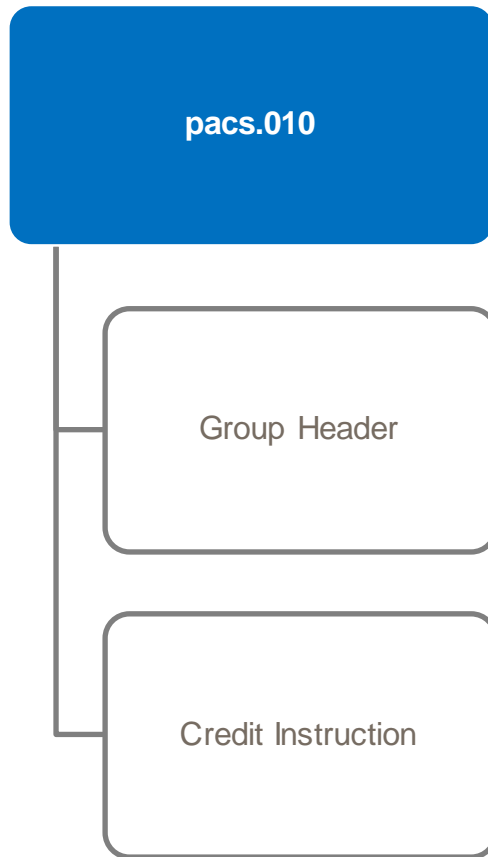

The pac010 has two core sets of nested elements:

- **Group Header** which contains a set of characteristics that relates to the transaction
- **Credit Instruction** which contains elements providing information specific to direct debit transaction information and credit instruction.



Typically a Direct Debit message in a many-to-many payment (FINplus service) would be considered a point-to-point message, successfully resulting in a payment transaction which may be exchange over various messages.

High Level message flow – book transfer

pacs.010

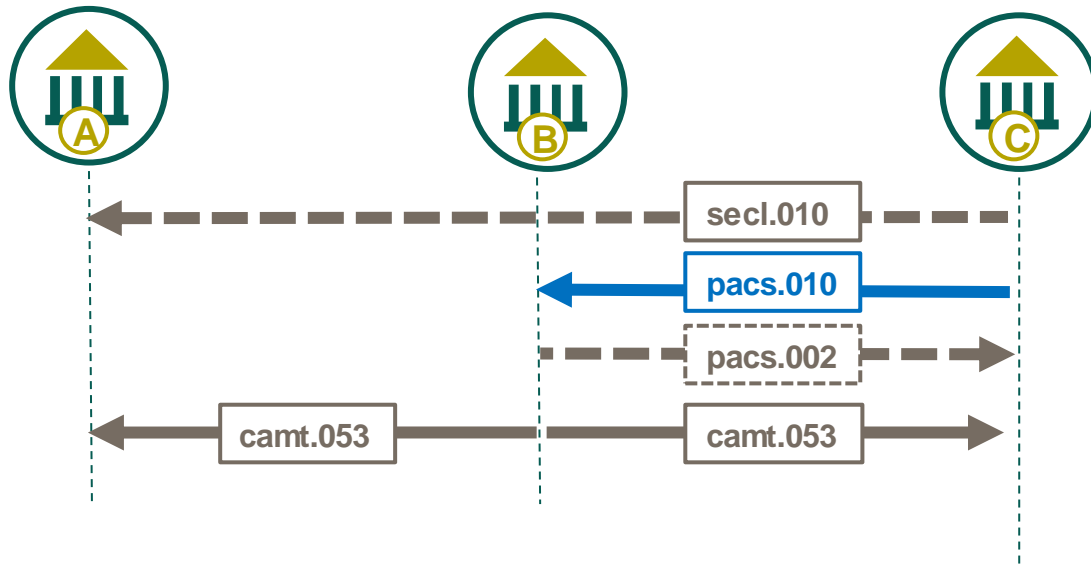

The Financial Institution Direct Debit message (pac.010) is sent by a Financial Institution, directly or through another agent, to the Debtor Agent. It is used to instruct the Debtor Agent to move funds from the Debtor's account to the Creditor, where both Debtor and Creditor are financial institutions.

High Level message flow – payment

pacs.010

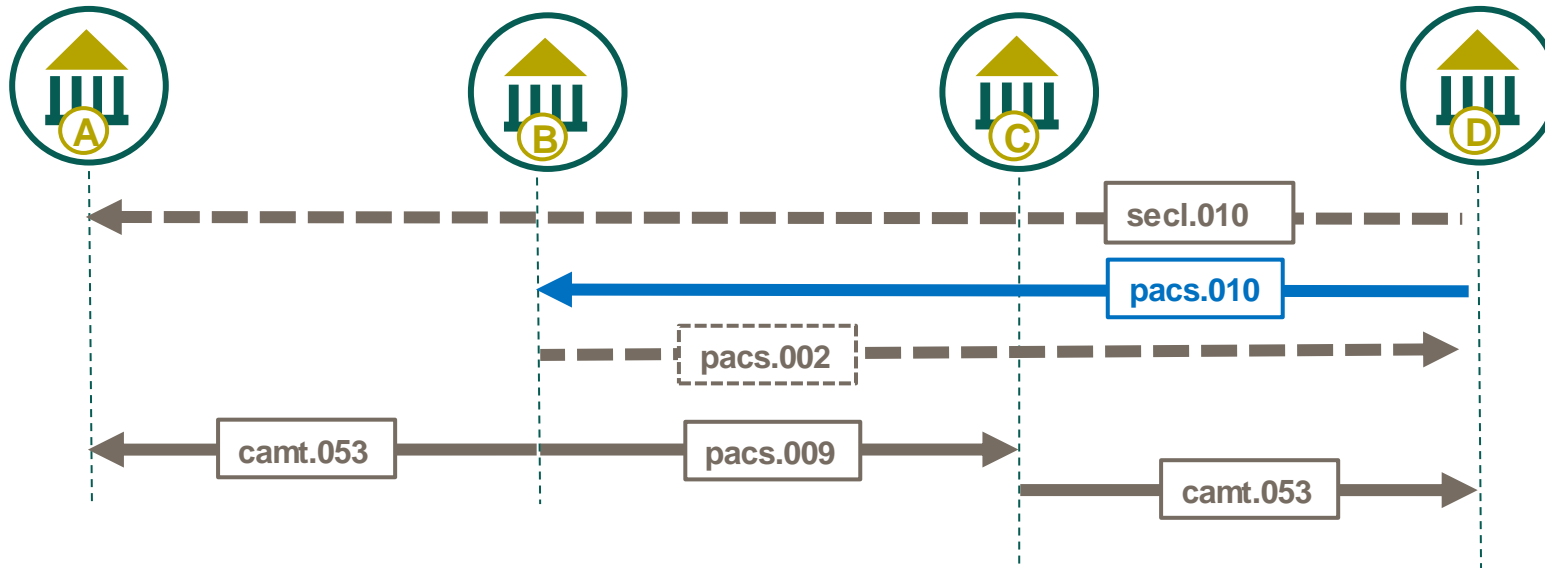

The Financial Institution Direct Debit message (pacs.010) is sent by a Financial Institution, directly or through another agent, to the Debtor Agent. It is used to instruct the Debtor Agent to move funds from the Debtor's account to the Creditor, where both Debtor and Creditor are financial institutions.

Group Header



pac.010 Financial Institution Direct Debit - Message Identification

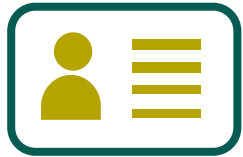

Min 1 – Max 1

Each ISO 20022 payment message has a **Message Identification** element, located in the Group Header. This **35 character** identifier is a point-to-point reference used to unambiguously identify the message.

For Payment Clearing and Settlement (pac) messages the Message Identification has no exact equivalent in the legacy MT payment message. However, the Sender's Reference (Field 20) could be considered a similar comparison where a pac message contains a single Transaction.

Group Header ➤ Message Identification

pac.010 Financial Institution Direct Debit – Creation Date Time

Min 1 – Max 1

The pac.010 message **Creation Date Time** captures the date and time which the message was created.

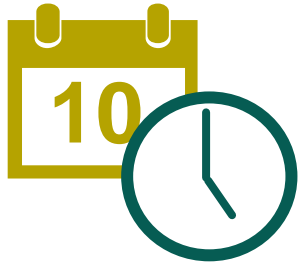

CBPR+ usage guidelines mandate the time zone that the time represents as an offset against Universal Time Coordinated (UTC):

Local time with UTC offset YYYY-MM-DDThh:mm:ss.sss+/-hh:mm

- For example: 2002-10-10T12:00:00-05:00 (noon/midday on 10 October 2002, Central Daylight Savings Time as well as Eastern Standard Time in the U.S.)



All CBPR+ time elements need offset against UTC. Milliseconds are optional.

Group Header ➤ Creation Date Time

pac.010 Financial Institution Direct Debit - Number of Transactions

Min 1 – Max 1

The pac.0010 message ***Number of Transactions*** captures the number of individual transaction contained within the message.



The number of transactions in CBPR+ payment usage guidelines is fixed to 1.



Single transactions in the CBPR+ payment usage guidelines enable a transaction to be managed and unlocks highly automated, frictionless, instant payments, supporting the next generation of innovation.

Group Header ➤ *Number of Transactions*

Credit Instruction



pac.010 Financial Institution Direct Debit – Credit Identification

Min 1 – Max 1

The Financial Institution Direct Debit **Credit Identification** provides a mandatory element to identify the Direct Debit instruction.



Unique reference assigned by the account servicer to unambiguously identify the account report. Directly comparable with the *Transaction Reference Number* (Field 20) of the legacy MT Financial Markets Direct Debit message.

Credit Instruction ➤ Credit Identifier

pacs.010 Financial Institution Direct Debit - Instructed and Instructing Agents

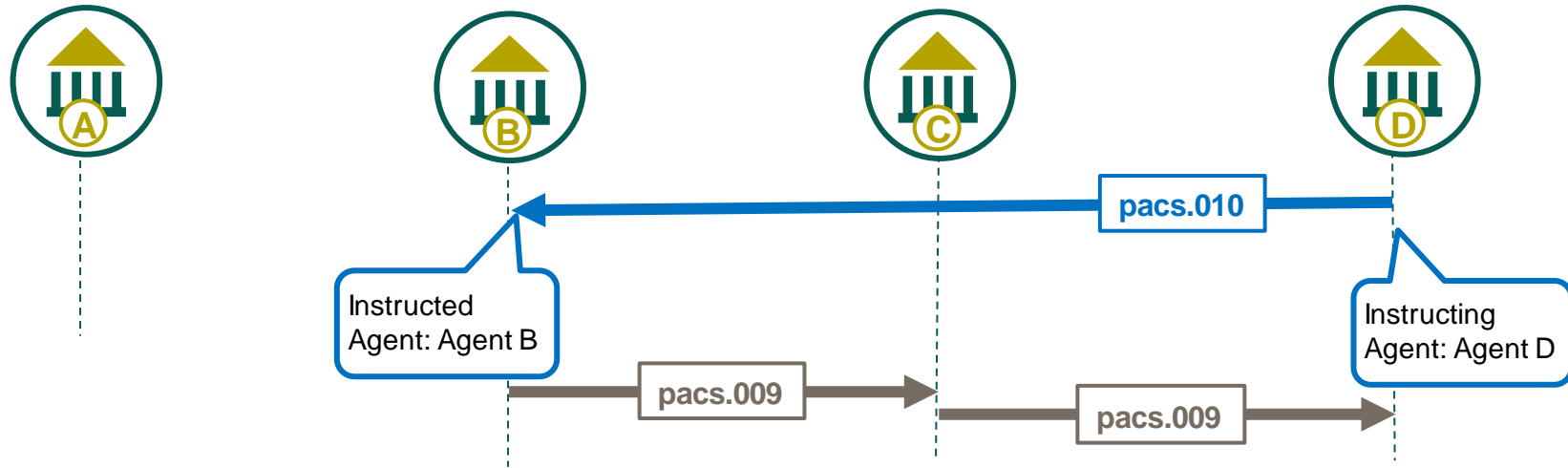

Instructing Agent and **Instructed Agent** represent the Agents involved in the pacs point-to-point message exchange. These roles therefore change on each message leg.



Instructing Agent and **Instructed Agent** elements are required in all pacs messages and is only available in the **Credit Instruction**.

Credit Instruction

Instructing Agent

Instructed Agent

pac010 Financial Institution Direct Debit – Creditor Agent & Creditor Agent Account

Min 0 – Max 1

The **Creditor Agent** is a static role in the pac010 messages. This agent maintains a relationship with their customer, the **Creditor**. Like the pac009 the Creditor Agent is optional, which covers the scenario where the Debtor and Creditor (as Financial Institutions) maintain a direct Nostro/Vostro account relationship, or where the Debtor Agent maintains the account of both the Debtor and Creditor.



Min 0 – Max 1

Where the **Creditor Agent** is utilised the **Creditor Agent Account** may optionally be used to capture the account of the Creditor Agent with the Agent immediate before them in the transaction chain (the Agent Serving their account)

This would only apply where the message includes a *Creditor Agent*, however CBPRplus does not recommend to use this element unless mandated within a community or bilaterally agreed.

Credit Instruction

Creditor Agent

Creditor Agent Account

pac.010 Financial Institution Direct Debit – Creditor

The ISO 2022 pac messages describe the Agent whose account is credited for a transaction as the **Creditor**. The *Creditor* sub elements describe the *Creditor* in greater detail.

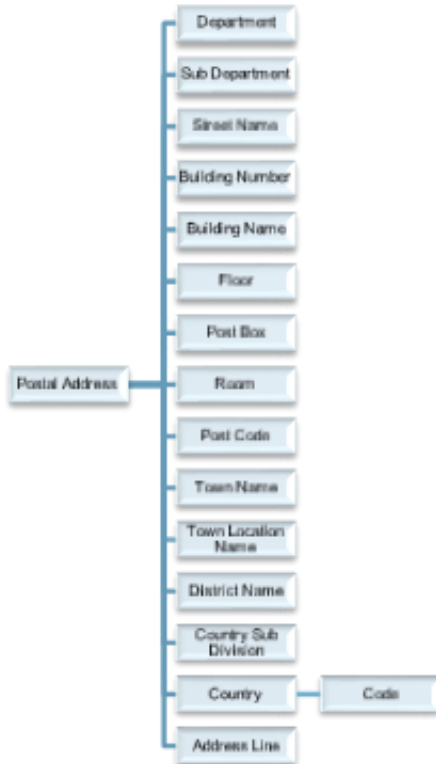

Information used to identify a Debtor by a clearing system identifier.

The BIC which identifies the *Creditor*

Legal entity identifier of the financial institution.

Name by which the Agent is known

Nested element capturing either structured or unstructured *Creditor* address details

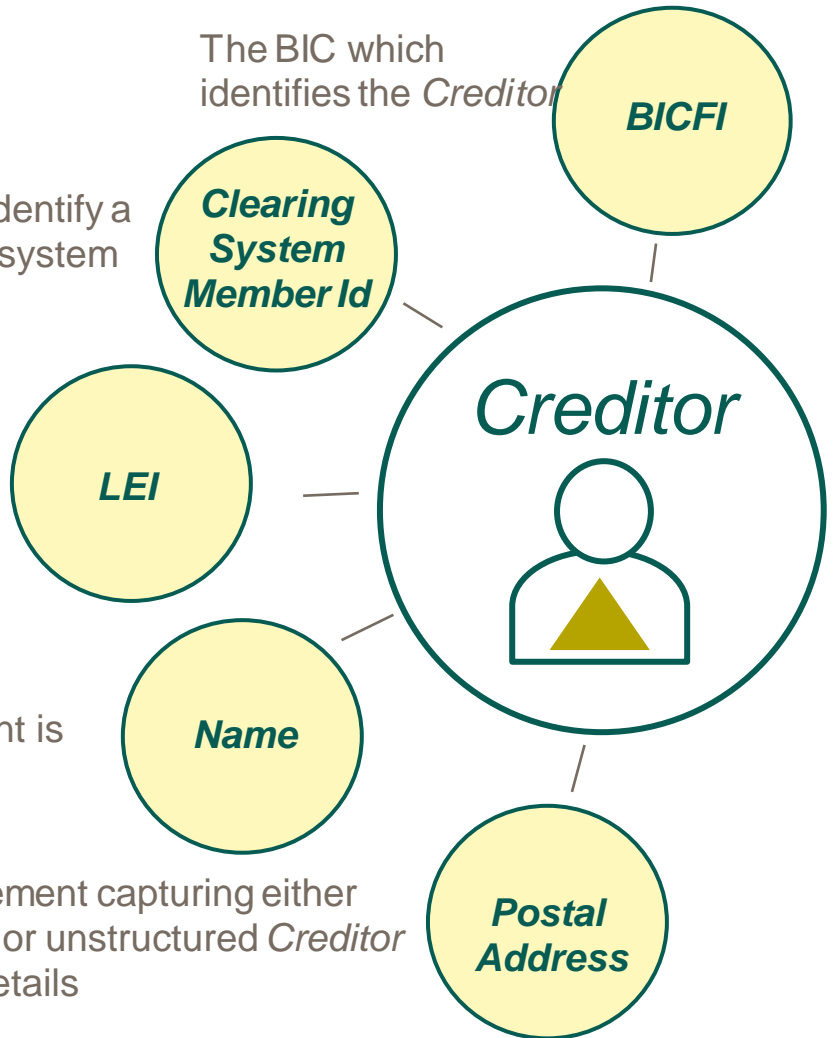

paces.010 Financial Institution Direct Debit – Creditor Account

Min 0 – Max 1

The Financial Institution Direct Debit **Creditor Account** provides an optional element to identify the Creditor's Account for which the Direct Debit instruction intends to instruct the movement of money to.

Min 1 – Max 1

a unique **Identification** for the account, between the Account Servicer and Account Owner. The element is further nested by choice of **IBAN** or **Other** to capture the account.

An element which may either use an external ISO **Cash Account Type code** or a proprietary code. It is used to identify a particular type of account.

The **Currency** for which the account is held. This is identified using the three characters **ISO currency code**.

The Name of the Account, as Assigned by the servicing institution.

A nested element which contains a Proxy Identifier together with the Proxy Type represented by either use an external ISO **Proxy Account Type code** or a proprietary code.

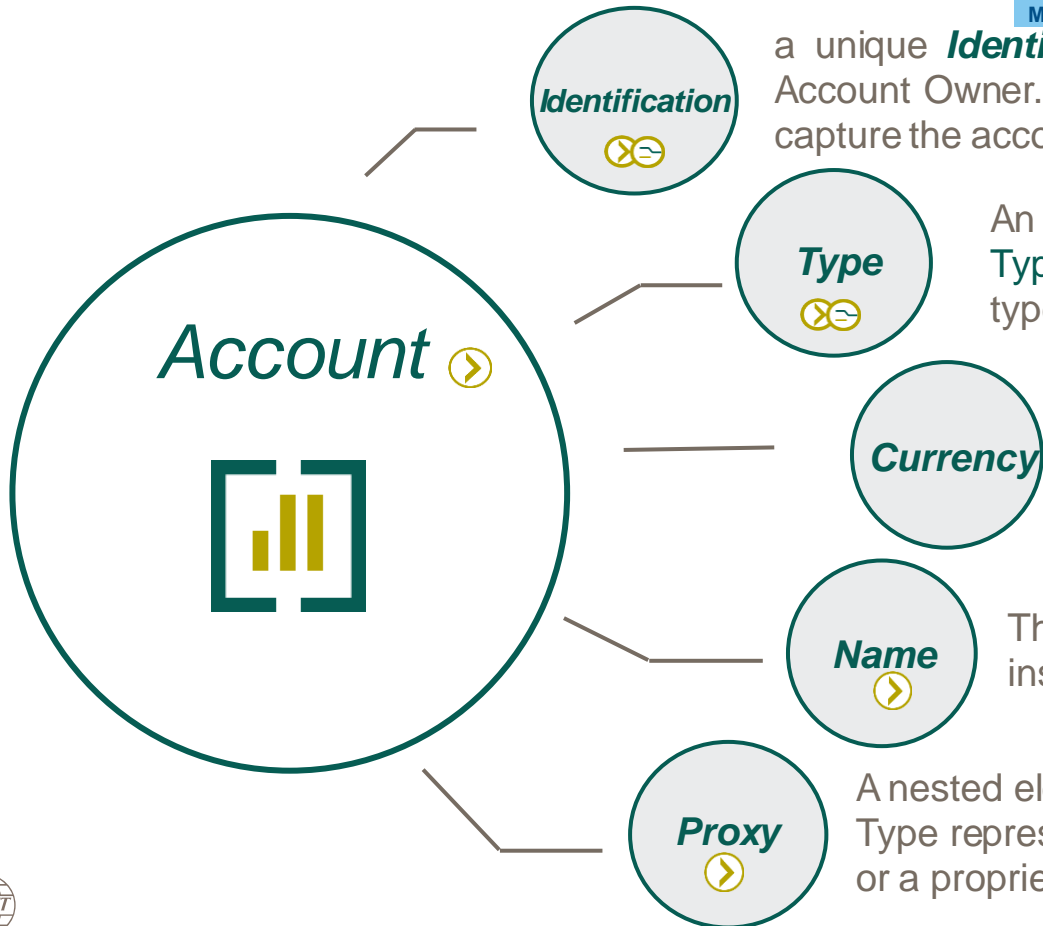

pac010 Financial Institution Direct Debit – Direct Debit Transaction Information

Min 1 – Max 1

The Financial Institution Direct Debit message **Direct Debit Transaction Information** nested element captures information related to the Debit part of the transaction, such as the Debtor, the amount and settlement date.



It is important to recognise that the data elements contained in this part of the Direct Debit message are identical to the pac009 Financial Institution Credit Transfer message which represents the next stage of the journey should the Direct Debit be accepted.



*From a business perspective authorisation of a direct debit instruction can be predetermined in a couple of ways (as CBPR+ is not operating a Direct Debit scheme). Either **third party debt authority** could be granted to the Agent instructing of the Direct Debit, or the **Payment Identification** could be used to capture a static or incremental value (i.e., a mandate) to determine if the Agent instructing the Direct Debit has been authorised to debit the account.*

Credit Instruction 

Direct Debit Transaction Information 

pacs.010 Financial Institution Direct Debit Margin Payment - Payment Identification

Min 1 – Max 1

The pacs message **Payment Identification** provides a set of elements to identify the payment, of which several are mandatory elements

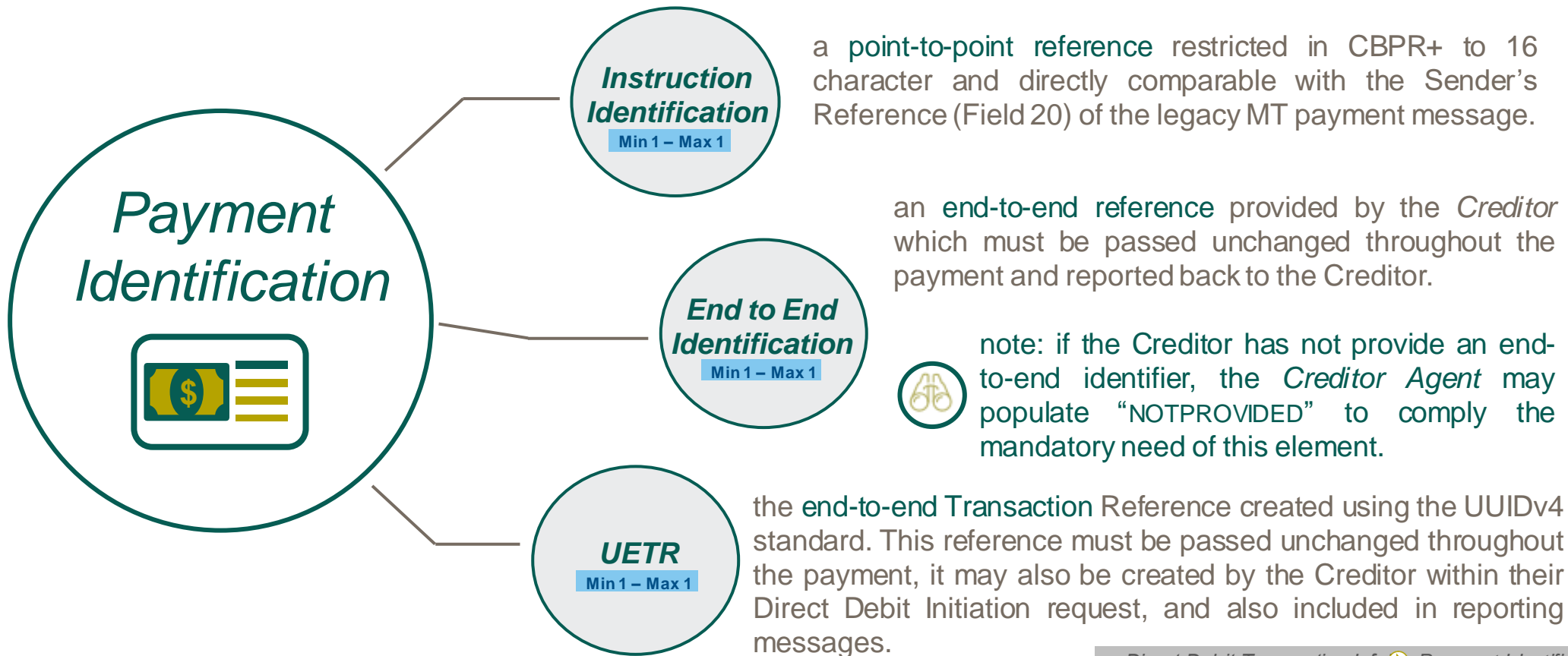

pac.010 Financial Institution Direct Debit Margin Payment - Payment Identification (continued)

The pac.010 message *Payment Identification* ^{Min 1 – Max 1} also provides a set of optional elements to identify the direct debit transaction.

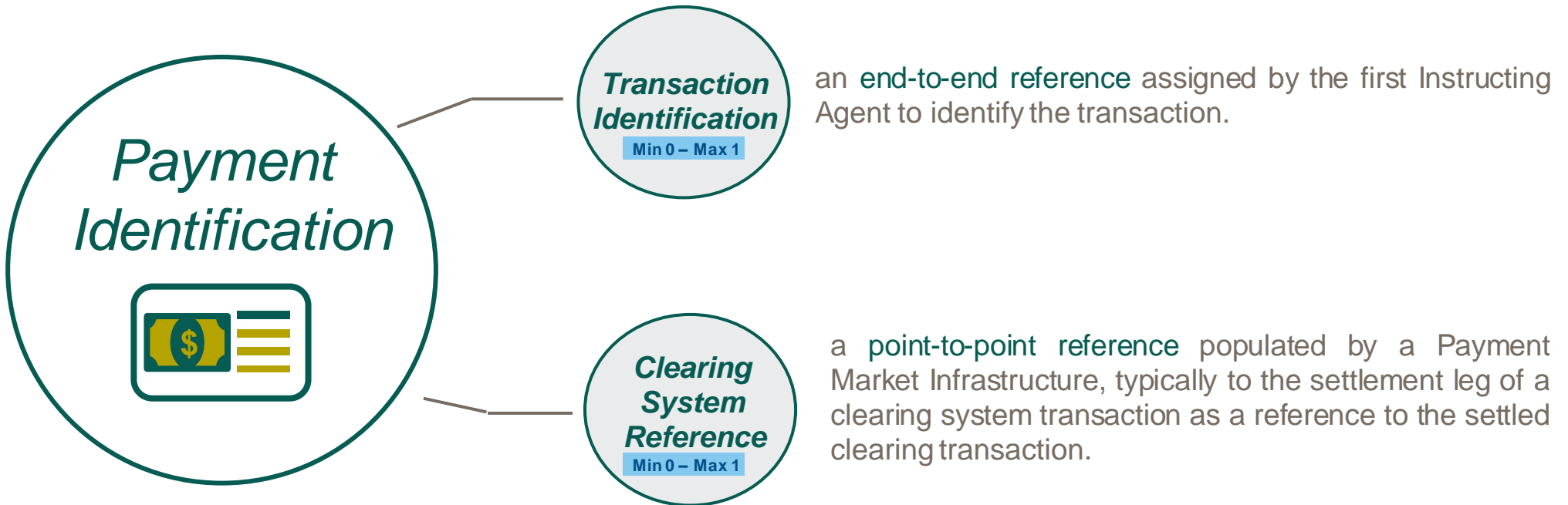

pacs.010 Financial Institution Direct Debit - Payment Type Information

The Financial Institution Direct Debit message **Payment Type Information** provides a set of optional elements where the payment type can be described.

a choice of imbedded codes representing the urgency considered by the Instructing Agent, this point-to-point information may be used by the Instructed Agent to differentiate the processing priority.

Instruction Priority

Min 0 – Max 1

Service Level

Min 0 – Max 3

Payment Type Information

Local Instrument

Min 0 – Max 1

Category Purpose

Min 0 – Max 1

A nested element which may either use an external ISO Service Level code or a proprietary code. It is used to identify a particular agreed service level which should be applied to the payment.

A nested element which may either use an external ISO Local Instrument code or a proprietary code. It is used to identify the type of payment local instrument such as a Standing Order.



Note: the ISO instrument codes are registered by specific community group (captured in the code list)

A nested element which may either use an external ISO Category Purpose code or a proprietary code. It is used to identify the category of payment. For example, SECU Transaction is the payment of securities.



Credit Instruction

Direct Debit Transaction Information

Payment Type Info'

pacs.010 Financial Institution Direct Debit – Currency and Amount

The pacs.010 message (unlike the pacs.008) has one element to capture the amount of the Transfer, **Interbank Settlement Amount**.

Min 1 – Max 1

**Interbank
Settlement
Amount**

A mandated currency amount moved between the *Instructing Agent* and the *Instructed Agent*. This therefore is the point-to-point currency amount exchanged, comparable with the MT Field 32



Note: the Financial Institution Direct Debit (pacs.010) has no *Instructed Amount* element, *Exchange Rate* or *Charger Bearer* (like the pacs.009) as the Instructed Settlement Amount is expected to be transferred across the end-to-end payment chain without any charges being applied or currency conversions.

Credit Instruction 

Direct Debit Transaction Information 

 Interbank Settlement Amount



pacs.010 Financial Institution Direct Debit – Interbank Settlement Date

Min 1 – Max 1

The Financial Institution Direct Debit message *Interbank Settlement Date* captures the *Date* the transaction is completed/effectuated.



This *Date* element use ISODate YYYY-MM-DD

For example: 2002-10-10 (10 October 2002)



Credit Instruction ✓

Direct Debit Transaction Information ✓

Interbank Settlement Date

pac010 Financial Institution Direct Debit – Settlement Time Request

Min 0 – Max 1

The Financial Institution Direct Debit message **Settlement Time Request** captures the requested settlement time as a choice of nested elements.

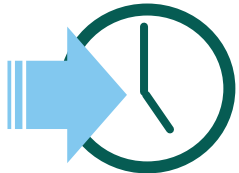

Where **Settlement Time Request** is used the nested:

- **CLS Time** Min 0 – Max 1
- **Till Time** Min 0 – Max 1
- **From Time** Min 0 – Max 1
- **Reject Time** Min 0 – Max 1

may be used to capture information related to this time.

Credit Instruction ✓

Direct Debit Transaction Information ✓

➤ Settlement Time Request

pac.010 Financial Institution Direct Debit – Debtor

The ISO 2022 pac messages describe the Agent whose account is debited for a transaction as the **Debtor**. The *Debtor* sub elements describe the *Debtor* in greater detail.

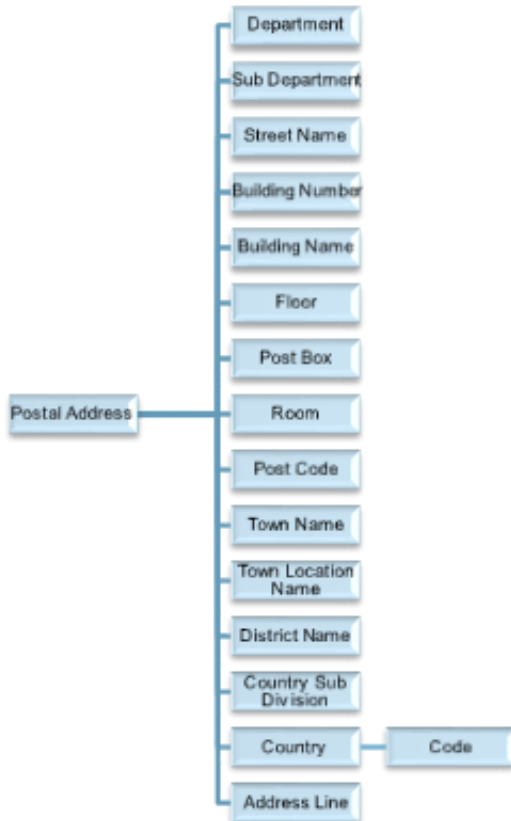

Information used to identify a Debtor by a clearing system identifier.

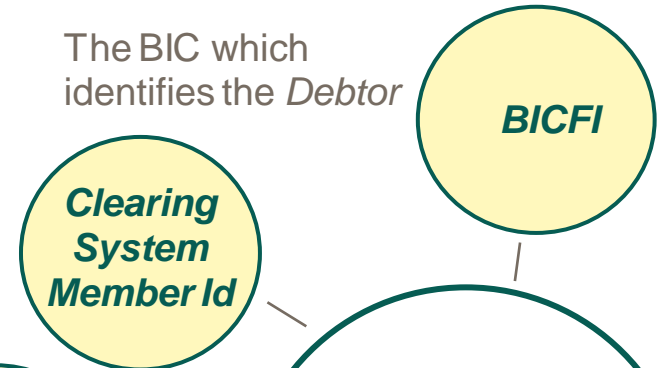

The BIC which identifies the *Debtor*

Legal entity identifier of the financial institution.

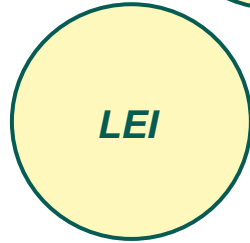

Name by which the Agent is known

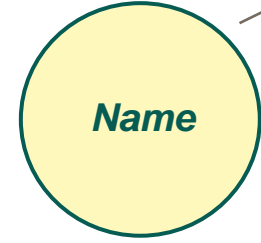

Nested element capturing either structured or unstructured *Debtor* address details



pacs.010 Financial Institution Direct Debit – Debtor Account

The Financial Institution Direct Debit message **Debtor Account** also provides an number of optional nested element to identify the account for which debit and credit entries have been made.

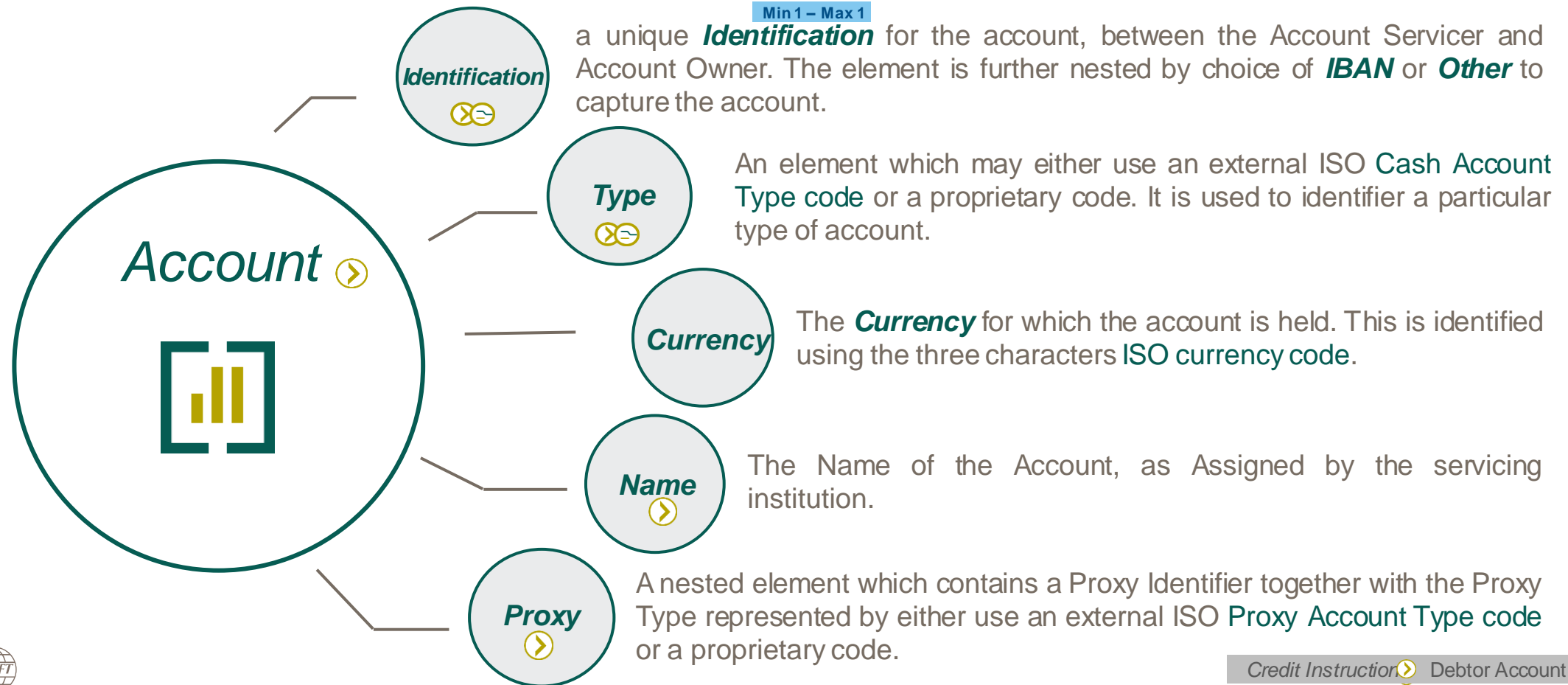

pacs.010 Financial Institution Direct Debit – Debtor Agent and Debtor Agent Account

Min 0 – Max 1

The **Debtor Agent** is a static role in the pacs messages. This agent maintain a relationship with their customer, the **Debtor**. Like the pacs.009 the Debtor Agent is optional, which cover the scenario where the Debtor and Creditor (as Financial Institutions) maintain a direct Nostro/Vostro account relationship, or where the Debtor Agent maintain the account of both the Debtor and Creditor.



Min 0 – Max 1

Where the **Debtor Agent** is utilised the **Debtor Agent Account** may optionally be used to capture the account of the Debtor Agent with the Agent immediate after them in the transaction chain (the Agent Serving their account)
This would only apply where the message includes a **Debtor Agent**, however CBPRplus does not recommend to use this element unless mandated within a community or bilaterally agreed.

Credit Instruction

Debtor Agent

Debtor Agent Account

pac.010 Financial Institution Direct Debit – Instruction For Debtor Agent

The *Instruction for Debtor Agent* elements within the pac.010 Financial Institution Direct Debit optionally provides information related to the processing of the direct debit instruction.



Min 0 – Max 1

The *Instruction for Debtor Agent* element offers a occurrence of free format information.

The use of this element should be **bilaterally** agreed with the *Debtor Agent* to maximize the ability to Straight Through Process the instruction.

pac.010 Financial Institution Direct Debit – Purpose

Min 0 – Max 1

The **Purpose** elements within the pac.010 Financial Institution Direct Debit capture the reason for the payment transaction which would result from a successful direct debit. This element may either use an external ISO **Purpose code** or a proprietary code.

The purpose is used by the capture the nature of the payment e.g. **CORT** Trade Settlement Payment, **CFEE** Cancellation Fees etc. and should not be confused with Regulatory Reporting codes.



The externalised Purpose code set is classified by the purpose, for example commercial, for which the numerous codes within the classification are each described by Name and Definition.

For example:

OTCD is classified within the Collateral categorisation, with the *Name* **OTC Derivatives** described as a **Cash collateral related to over-the-counter (OTC) Derivatives** - in general for example contracts which are traded and privately negotiated.

pacs.010 Financial Institution Direct Debit – Remittance Information

The optional **Remittance Information** element within the pacs.010 Financial Institution Direct Debit is nested to provide **Unstructured** information related to payment.

Min 0 – Max 1

Remittance Information enable the matching/reconciliation of an entry that the payment is intended to settle

Min 0 – Max 1

The **Unstructured** sub element captures free format *Remittance Information* which is restricted in CBPR+ to 140 characters to ensure backward compatibility with the legacy MT message during coexistence.



Note: like the pacs.009 *Remittance Information* can only be captured in an *Unstructured* element.

Remittance Information is however a dedicated element used both within the pacs and camt reporting messages, whereby this information can travel end-to-end using ISO 20022.

Credit Instruction > Remittance Information ✓

Unstructured

Index of pacs.010 Use Cases

Use case should be considered as a principal example whereby use case may be cross referenced e.g. a use case involving a Market Infrastructure can apply the Market Infrastructure legs to other use cases.

Financial Institution Direct Debit

Use Case p.10.1.1 - High Level Payment of a Financial Institution Direct Debit (pacs.010)

Use Case p.10.1.1.a - High Level Book movement of a Financial Institution Direct Debit (pacs.010)

Use Case p.10.1.2 - High Level Rejection of a Financial Institution Direct Debit (pacs.010)

High Level Payment Of A Financial Institution Direct Debit (pacs.010)

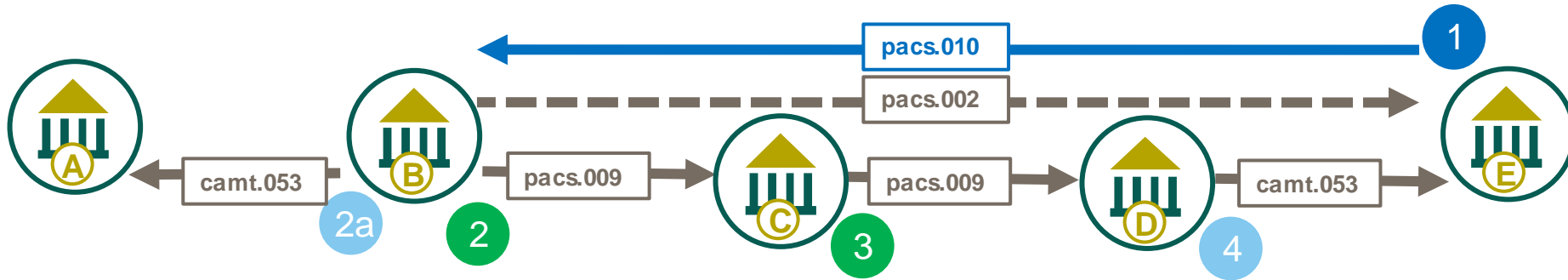

1 Agent E initiates a Direct Debit instruction to debit Agent A's account

2 Debtor Agent (B) initiates a serial payment towards the Creditor Agent (E) using Agents B & C as intermediaries

2a Debtor Agent (B) debits the Debtor (Agent A) optionally provide a notification e.g. credit notification in addition to an account statement (camt.053)

3 Agent C processes the payment on Agent D

4 Agent D credits the account of the Creditor (Agent E), and may optionally provide a notification e.g. credit notification in addition to an account statement (camt.053)

High Level Book movement of a Financial Institution Direct Debit (pacs.010)

Use Case p.10.1.1.a

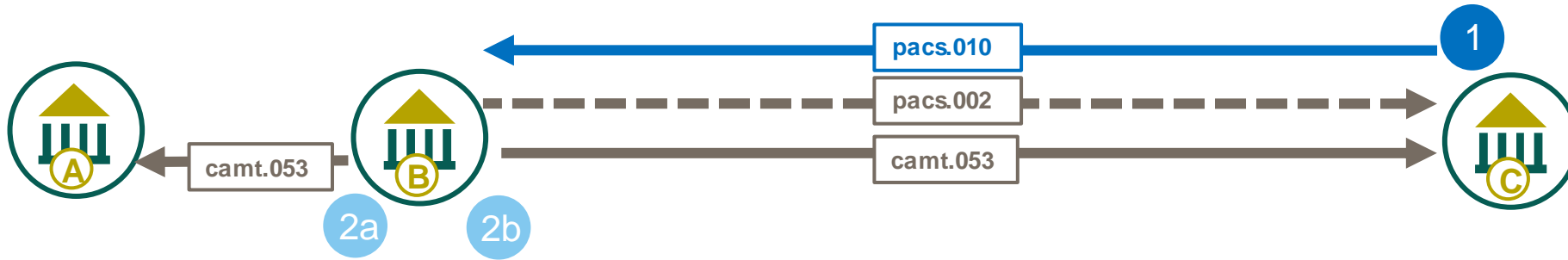

1

Agent E initiates a Direct Debit instruction to debit Agent A's account

2a

Debtor Agent (B) debits the Debtor (Agent A) optionally provide a notification e.g. credit notification in addition to an account statement (camt.053)

2b

Agent B credits the account of the Creditor (Agent C), and may optionally provide a notification e.g. credit notification in addition to an account statement (camt.053)

High Level Rejection Of A Financial Institution Direct Debit (pacs.010)

Use Case p.10.1.2

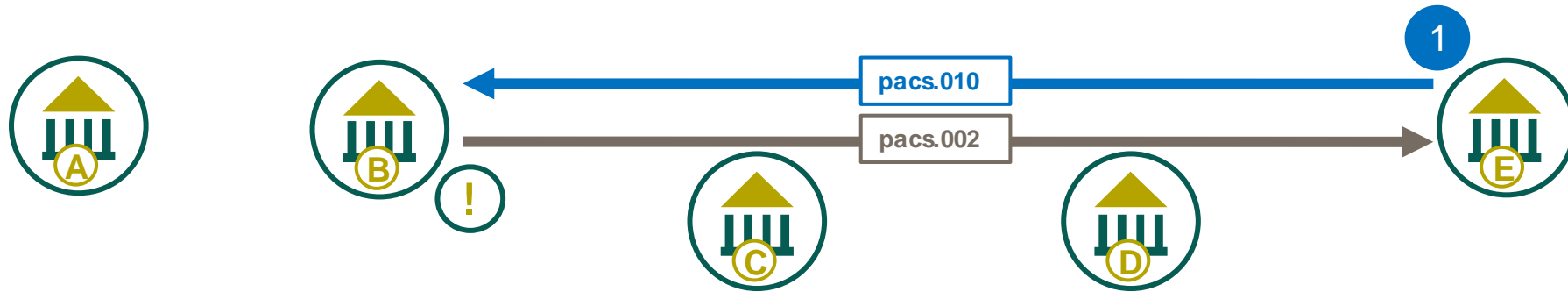

1

Agent D initiates a Direct Debit instruction to debit Agent A's account

!

Debtor Agent (B) rejects the instruction, using a pacs.002, as no mandate agreement is in place.



Financial Institution Direct Debit – Margin Collection

pac010 Financial Institution Direct Debit Margin Payment

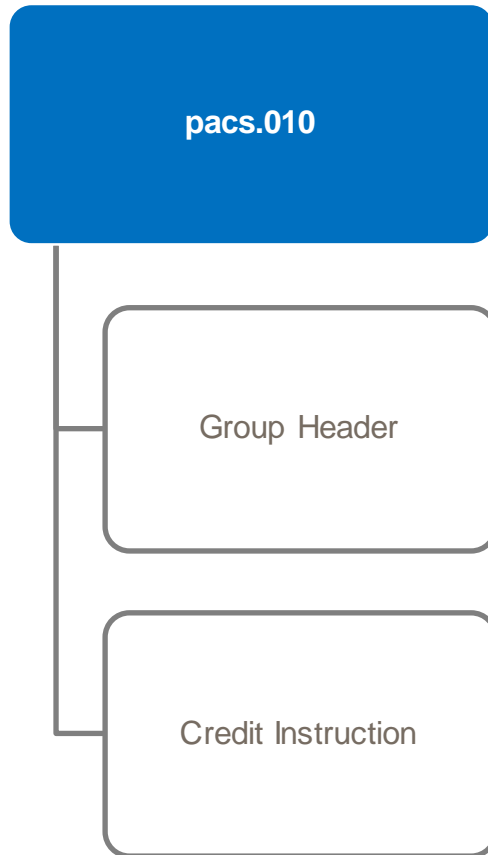

The pac010 has two core sets of nested elements:

- **Group Header** which contains a set of characteristics that relates to the transaction
- **Credit Instruction** which contains elements providing information specific to direct debit transaction information and credit instruction.

The Financial Institution Direct Debit Margin Collection is designed to allow a Central Counterparty to collect money by triggering a payment. Whereby the pac010 Debit transfer the money to the Creditor using a pac009. Unlikely the pac010 Financial Institution Direct Debit additional Credit Instruction elements are allowed in this Usage Guideline.

The Financial Institution Direct Debit Margin Collection can be used for collection using the same message model.



High Level message flow

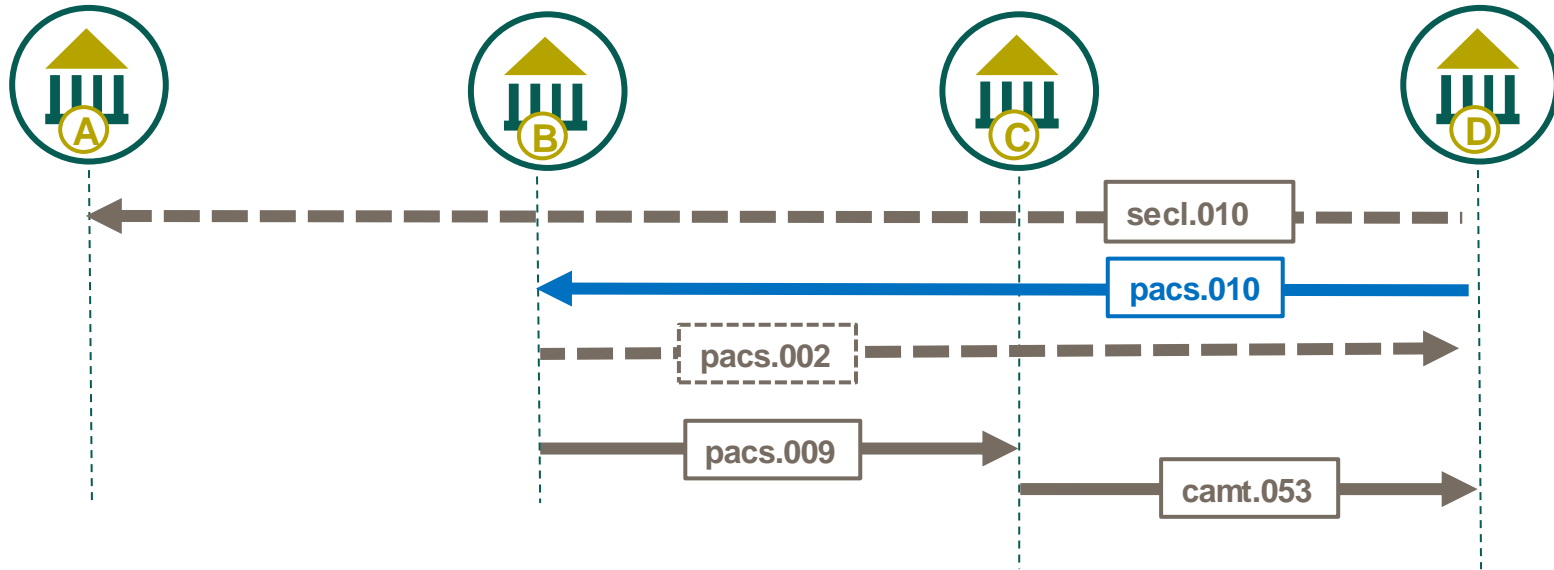

The Financial Institution Direct Debit message (pac.010) is sent by a Financial Institution, directly or through another agent, to the Debtor Agent. It is used to instruct the Debtor Agent to move funds from the Debtor's account to the Creditor, where both Debtor and Creditor are financial institutions.

Group Header



pac010 Financial Institution Direct Debit Margin Payment - Message Identification

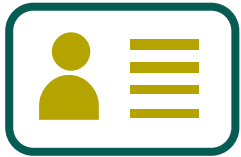

Min 1 – Max 1

Each ISO 20022 payment message has a **Message Identification** element, located in the Group Header. This **35 character** identifier is a point-to-point reference used to unambiguously identify the message.

For Payment Clearing and Settlement (pac0) messages the Message Identification has no exact equivalent in the legacy MT payment message. However, the Sender's Reference (Field 20) could be considered a similar comparison where a pac0 message contains a single Transaction.

Group Header → Message Identification

pac010 Financial Institution Direct Debit Margin Payment – Creation Date Time

Min 1 – Max 1

The pac010 message **Creation Date Time** captures the date and time which the message was created.

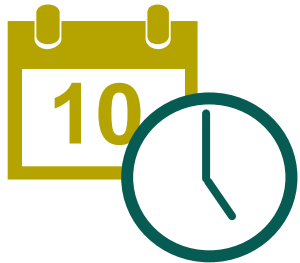

CBPR+ usage guidelines mandate the time zone that the time represents as an offset against Universal Time Coordinated (UTC):

Local time with UTC offset `YYYY-MM-DDThh:mm:ss.sss+/-hh:mm`

- For example: `2002-10-10T12:00:00-05:00` (noon/midday on 10 October 2002, Central Daylight Savings Time as well as Eastern Standard Time in the U.S.)



All CBPR+ time elements need offset against UTC. Milliseconds are optional.

Group Header ➤ Creation Date Time

pac010 Financial Institution Direct Debit Margin Payment - Number of Transactions

Min 1 – Max 1

The pac010 message **Number of Transactions** captures the number of individual transaction contained within the message.



The number of transactions in CBPR+ payment usage guidelines is fixed to 1.



Single transactions in the CBPR+ payment usage guidelines enable a transaction to be managed and unlocks highly automated, frictionless, instant payments, supporting the next generation of innovation.

Group Header ▶ Number of Transactions

Credit Instruction



pacs.010 Financial Institution Direct Debit Margin Payment – Credit Identification

Min 1 – Max 1

The Financial Institution Direct Debit **Credit Identification** provides a mandatory element to identify the Direct Debit instruction.



Unique reference assigned by the account servicer to unambiguously identify the account report. Directly comparable with the *Transaction Reference Number* (Field 20) of the legacy MT Financial Markets Direct Debit message.

Credit Instruction ➤ Credit Identifier

pac010 Financial Institution Direct Debit Margin Payment – Credit Identification

Min 0 – Max 1

The pac0 message **Payment Type Information** provides a set of optional elements where the payment type can be described. These elements are applied to the pac009 which results from this message.

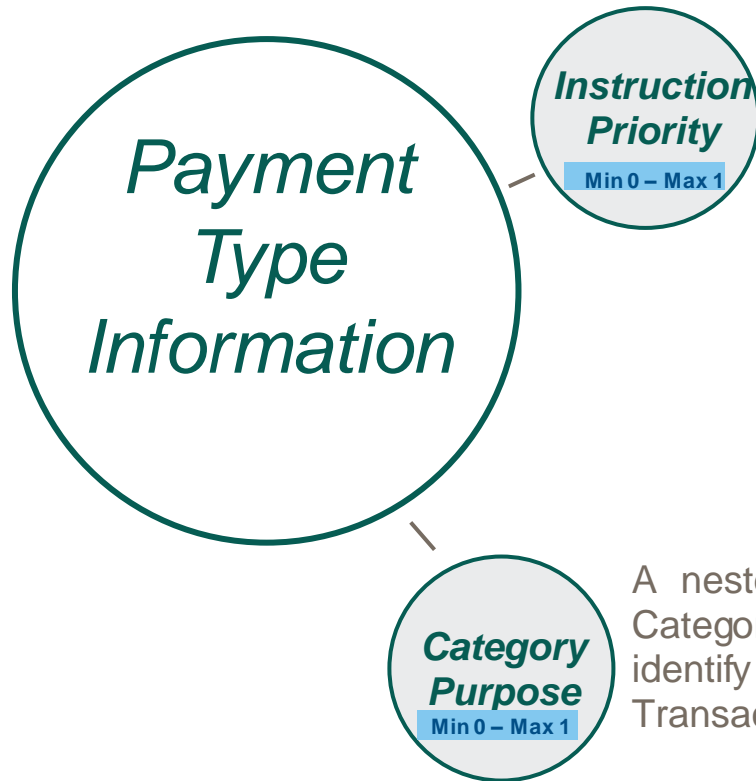

a choice of imbedded codes representing the urgency considered by the Instructing Agent, this point-to-point information may be used by the Instructed Agent to differentiate the processing priority.

A nested element which may either use an external ISO Category Purpose code or a proprietary code. It is used to identify the category of payment. For example, SECU Transaction is the payment of securities.



pacs.010 Financial Institution Direct Debit Margin Payment - Instructed and Instructing Agents

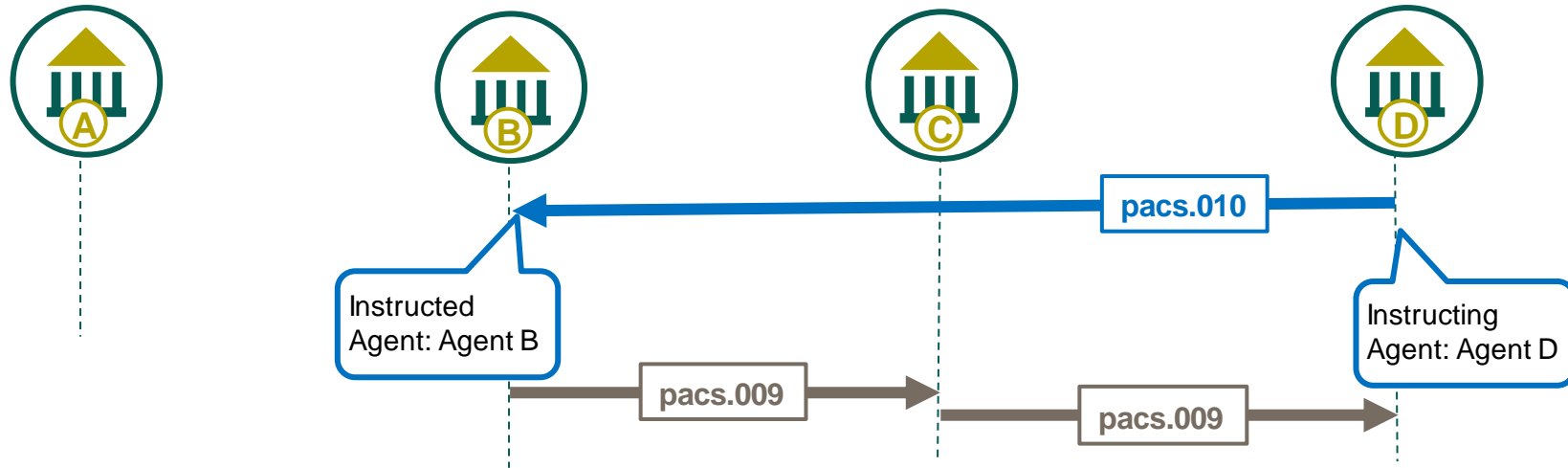

Instructing Agent and **Instructed Agent** represent the Agents involved in the pacs point-to-point message exchange. These roles therefore change on each message leg.



Instructing Agent and **Instructed Agent** elements are required in all pacs messages and is only available in the **Credit Instruction**.

Credit Instruction

Instructing Agent

Instructed Agent

paces.010 Financial Institution Direct Debit Margin Payment – Intermediary Agents

The pacs message can capture up to 3 Intermediary Agents, which play a dynamic role in the payment between the Debtor Agent and Creditor Agent.

Min 0 – Max 1

The **Intermediary Agent 1** captures the first Intermediary Agent between the Debtor Agent and Creditor Agent for who the Instructed Agent attempt to instruct the payment on to. This optional element is comparable with the Field 56a in the legacy FIN message.



Min 0 – Max 1

The **Intermediary Agent 1 Account** captured the account related to this Intermediary Agent, with the Instructed Agent. This element can be compared to the Party Identifier of the legacy Field 56a.

Min 0 – Max 1

The **Intermediary Agent 2** captures the second Intermediary Agent between the Intermediary Agent 1 and the Creditor Agent. This optional element has not comparable field in the legacy FIN message.



Min 0 – Max 1

The **Intermediary Agent 2 Account** captured the account related to this Intermediary Agent, with the Intermediary Agent 1. This optional element has not comparable field in the legacy FIN message.

Min 0 – Max 1

The **Intermediary Agent 3** captures the third Intermediary Agent between the Intermediary Agent 2 and the Creditor Agent. This optional element has not comparable field in the legacy FIN message.



Min 0 – Max 1

The **Intermediary Agent 3 Account** captured the account related to this Intermediary Agent, with the Intermediary Agent 2. This optional element has not comparable field in the legacy FIN message.



Debtor Agent and Creditor Agent elements must be present before the Intermediary Agent 1 element can be used

pacs.010 Financial Institution Direct Debit Margin Payment – Creditor Agent & Creditor Agent Account



Min 0 – Max 1

The **Creditor Agent** is a static role in the pacs messages. This agent maintain a relationship with their customer, the **Creditor**. Like the pacs.009 the Creditor Agent is optional, which cover the scenario where the Debtor and Creditor (as Financial Institutions) maintain a direct Nostro/Vostro account relationship, or where the Debtor Agent maintain the account of both the Debtor and Creditor.



Min 0 – Max 1

Where the **Creditor Agent** is utilised the **Creditor Agent Account** may optionally be used to capture the account of the Creditor Agent with the Agent immediate before them in the transaction chain (the Agent Serving their account)

This would only apply where the message includes a *Creditor Agent*, however CBPRplus does not recommend to use this element unless mandated within a community or bilaterally agreed.

Credit Instruction

Creditor Agent

Creditor Agent Account



pac.010 Financial Institution Direct Debit Margin Payment – Creditor

The ISO 2022 pac messages describe the Agent whose account is credited for a transaction as the **Creditor**. The *Creditor* sub elements describe the *Creditor* in greater detail.

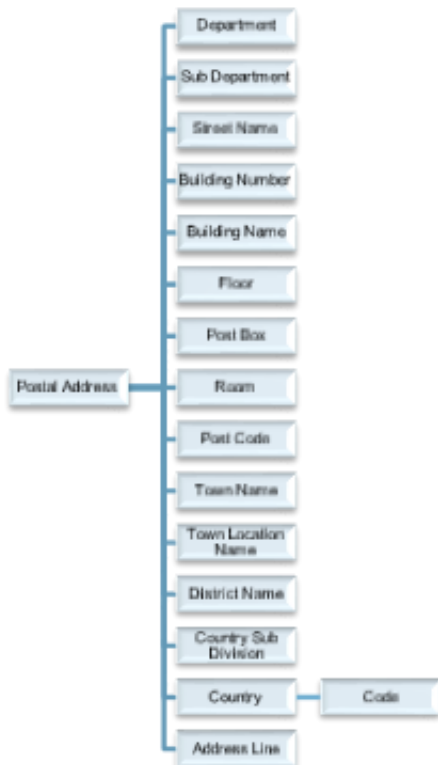

Information used to identify a Debtor by a clearing system identifier.

The BIC which identifies the *Creditor*

Legal entity identifier of the financial institution.

Name by which the Agent is known

Nested element capturing either structured or unstructured *Creditor* address details

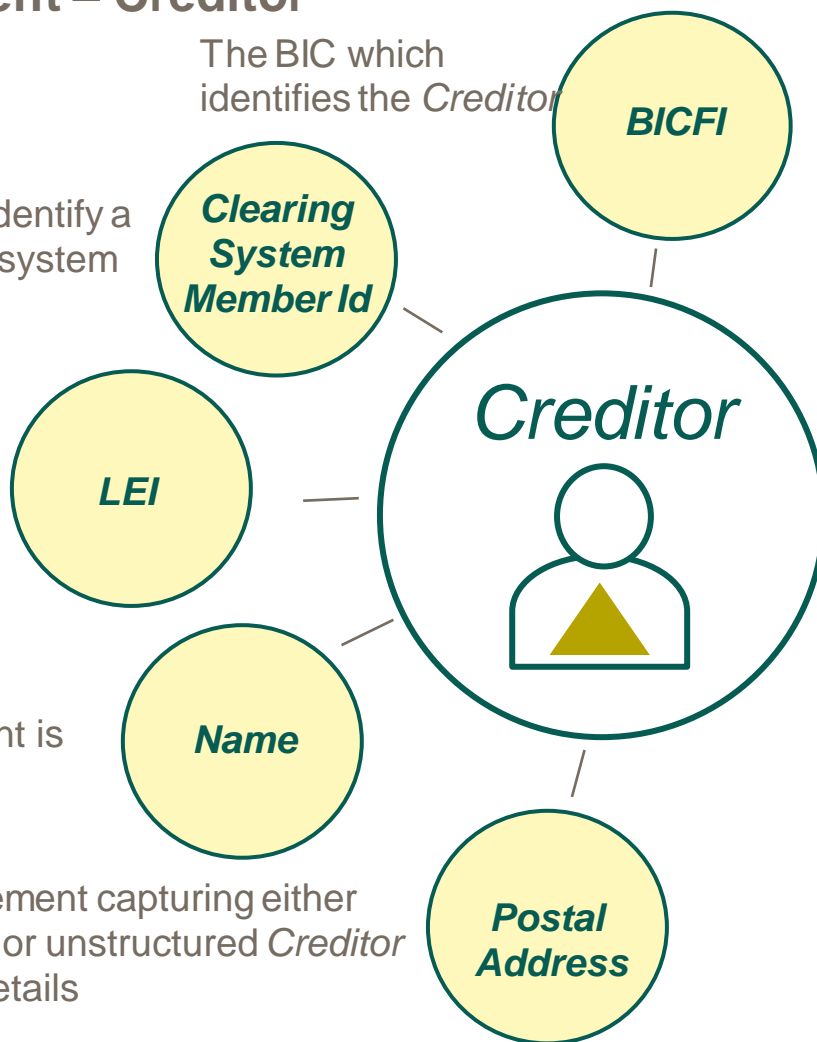

pacs.010 Financial Institution Direct Debit Margin Payment – Creditor Account

The Financial Institution Direct Debit **Creditor Account** provides an optional element to identify the Creditor's Account for which the Direct Debit instruction intends to instruct the movement of money to.

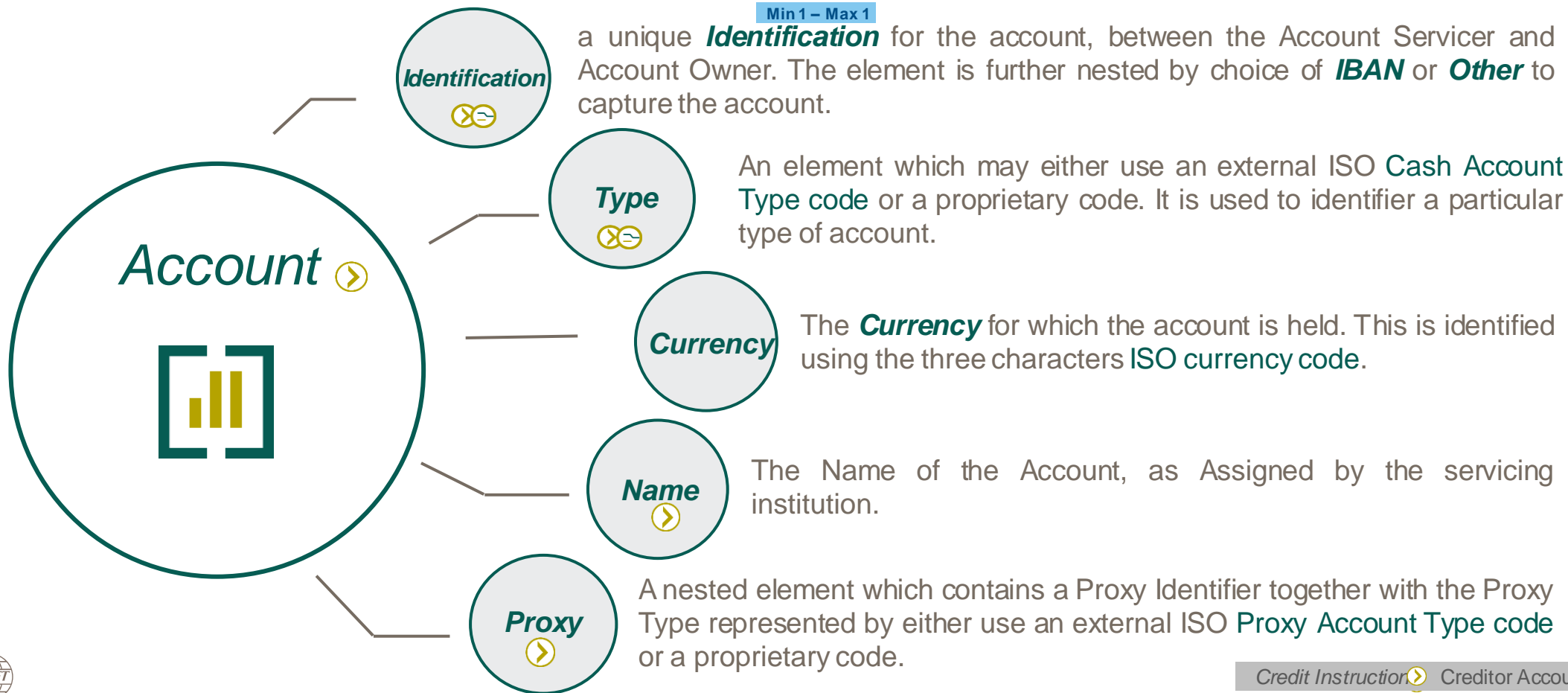

pacs.010 Financial Institution Direct Debit Margin Payment – Direct Debit Transaction Information

Min 1 – Max 1

The Financial Institution Direct Debit message **Direct Debit Transaction Information** nested element captures information related to the Debit part of the transaction, such as the Debtor, the amount and settlement date.



It is important to recognise that the data elements contained in this part of the Direct Debit message are identical to the pacs.009 Financial Institution Credit Transfer message which represents the next stage of the journey should the Direct Debit be accepted.



*From a business perspective authorisation of a direct debit instruction can be predetermined in a couple of ways (as CBPR+ is not operating a Direct Debit scheme). Either **third party debt authority** could be granted to the Agent instructing of the Direct Debit, or the **Payment Identification** could be used to capture a static or incremental value (i.e., a mandate) to determine if the Agent instructing the Direct Debit has been authorised to debit the account.*

Credit Instruction 

Direct Debit Transaction Information 

pacs.010 Financial Institution Direct Debit Margin Payment - Payment Identification

Min 1 – Max 1

The pacs message **Payment Identification** provides a set of elements to identify the payment, of which several are mandatory elements

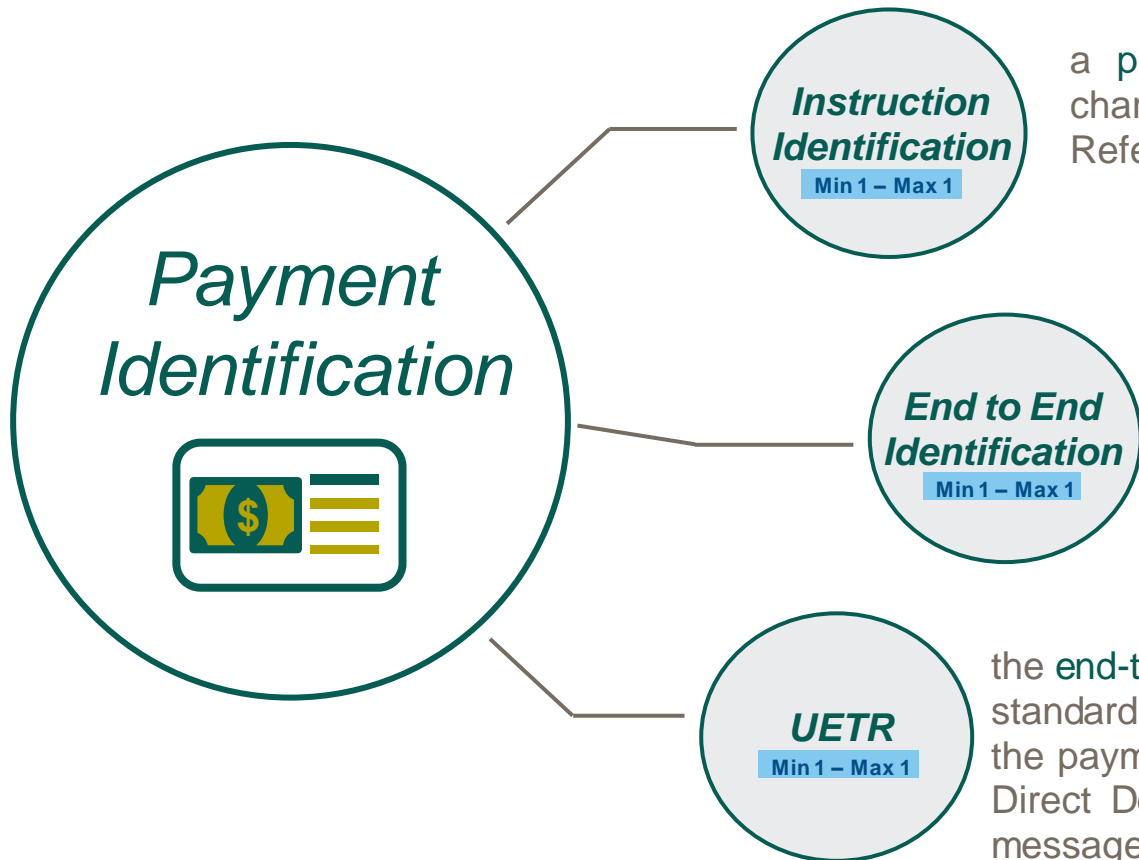

a **point-to-point reference** restricted in CBPR+ to 16 character and directly comparable with the Sender's Reference (Field 20) of the legacy MT payment message.

an **end-to-end reference** provided by the *Creditor* which must be passed unchanged throughout the payment and reported back to the Creditor.



note: if the Creditor has not provide an end-to-end identifier, the *Creditor Agent* may populate "NOTPROVIDED" to comply the mandatory need of this element.

the **end-to-end Transaction Reference** created using the UUIDv4 standard. This reference must be passed unchanged throughout the payment, it may also be created by the Creditor within their Direct Debit Initiation request, and also included in reporting messages.

pac010 Financial Institution Direct Debit Margin Payment - Payment Identification (continued)

The pac010 message **Payment Identification** ^{Min 1 – Max 1} also provides a set of optional elements to identify the direct debit transaction.

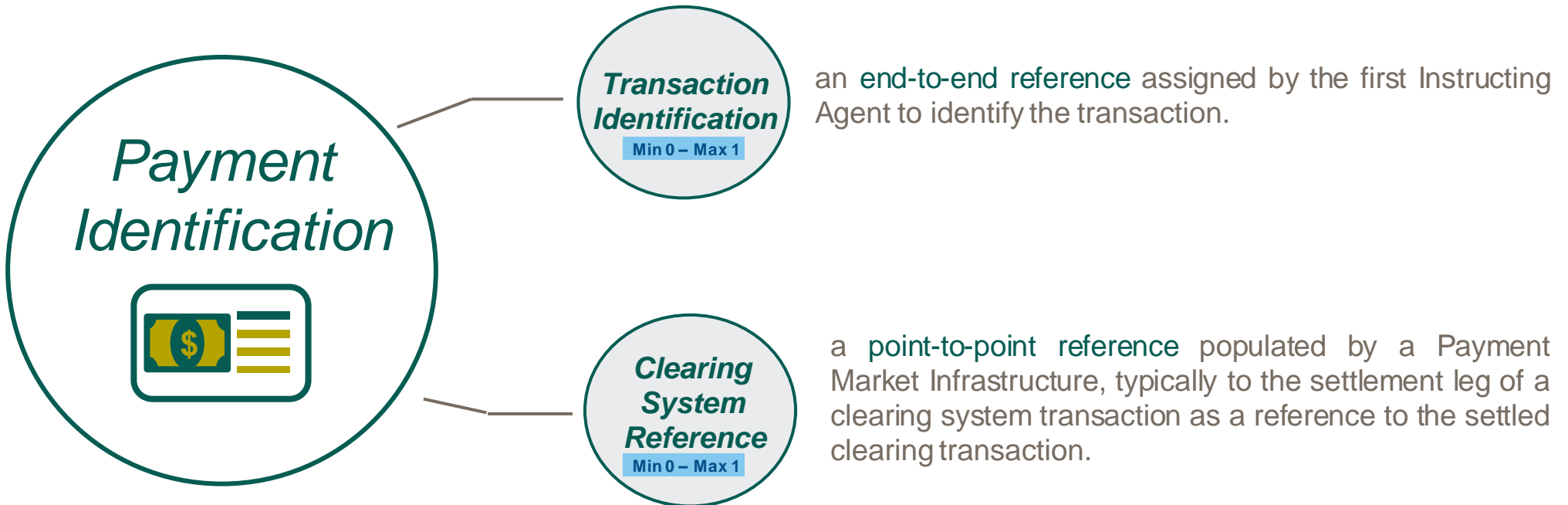

pacs.010 Financial Institution Direct Debit Margin Payment - Payment Type Information

The Financial Institution Direct Debit message **Payment Type Information** provides a set of optional elements where the payment type can be described. These elements apply to the debit transaction, whereby the Credit Instruction has its own Payment Type Information.

a choice of imbedded codes representing the urgency considered by the Instructing Agent, this point-to-point information may be used by the Instructed Agent to differentiate the processing priority.

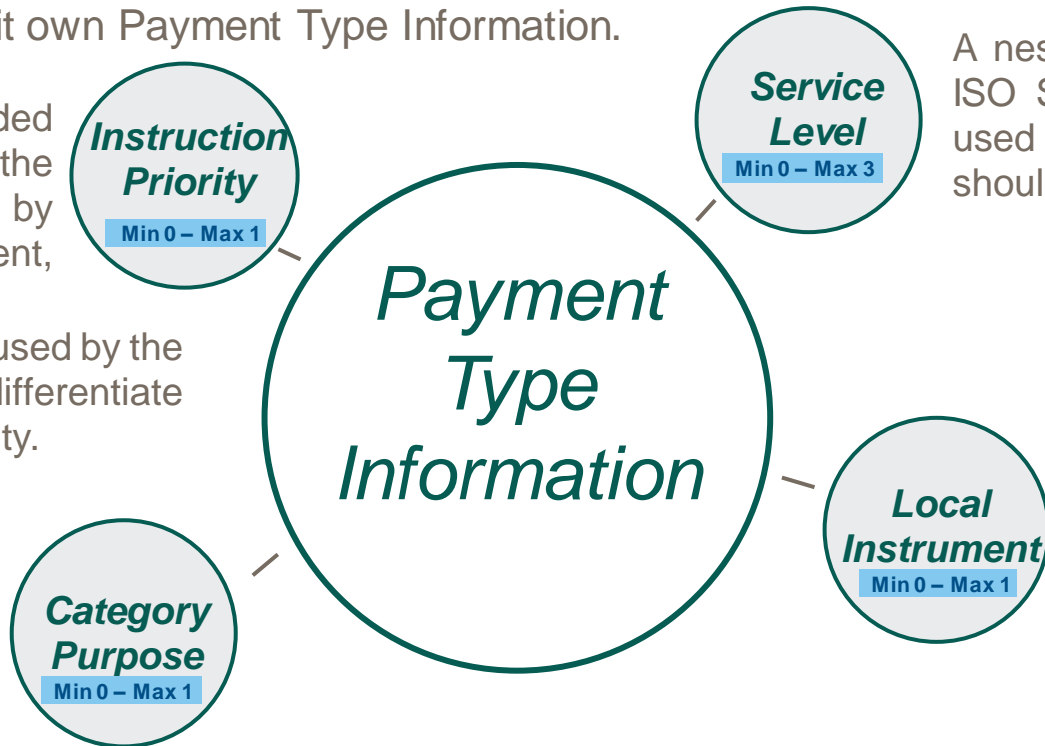

A nested element which may either use an external ISO Service Level code or a proprietary code. It is used to identify a particular agreed service level which should be applied to the payment.

A nested element which may either use an external ISO Local Instrument code or a proprietary code. It is used to identify the type of payment local instrument such as a Standing Order.



Note: the ISO instrument codes are registered by specific community group (captured in the code list)

A nested element which may either use an external ISO Category Purpose code or a proprietary code. It is used to identify the category of payment. For example, SECU Transaction is the payment of securities.

Credit Instruction

Direct Debit Transaction Information

Payment Type Info'



pac010 Financial Institution Direct Debit Margin Payment – Currency and Amount

The pac010 message (unlike the pac008) has one element to capture the amount of the Transfer, **Interbank Settlement Amount**.

Min 1 – Max 1

**Interbank
Settlement
Amount**

A mandated currency amount moved between the *Instructing Agent* and the *Instructed Agent*. This therefore is the point-to-point currency amount exchanged, comparable with the MT Field 32



Note: the Financial Institution Direct Debit (pac010) has no *Instructed Amount* element, *Exchange Rate* or *Charger Bearer* (like the pac009) as the Instructed Settlement Amount is expected to be transferred across the end-to-end payment chain without any charges being applied or currency conversions.

Credit Instruction

Direct Debit Transaction Information

Interbank Settlement Amount



pacs.010 Financial Institution Direct Debit Margin Payment – Interbank Settlement Date

Min 1 – Max 1

The Financial Institution Direct Debit message *Interbank Settlement Date* captures the *Date* the transaction is completed/effected.



This *Date* element use ISODate YYYY-MM-DD

For example: 2002-10-10 (10 October 2002)



Credit Instruction ✓

Direct Debit Transaction Information ✓

Interbank Settlement Date

pac010 Financial Institution Direct Debit Margin Payment – Settlement Time Request

Min 0 – Max 1

The Financial Institution Direct Debit message **Settlement Time Request** captures the requested settlement time as a choice of nested elements.

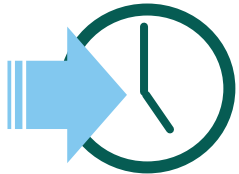

Where **Settlement Time Request** is used the nested:

- **CLS Time** Min 0 – Max 1
- **Till Time** Min 0 – Max 1
- **From Time** Min 0 – Max 1
- **Reject Time** Min 0 – Max 1

may be used to capture information related to this time.

Credit Instruction ✓

Direct Debit Transaction Information ✓

➤ Settlement Time Request

pac.010 Financial Institution Direct Debit Margin Payment – Debtor

The ISO 2022 pac messages describe the Agent whose account is debited for a transaction as the **Debtor**. The *Debtor* sub elements describe the *Debtor* in greater detail.

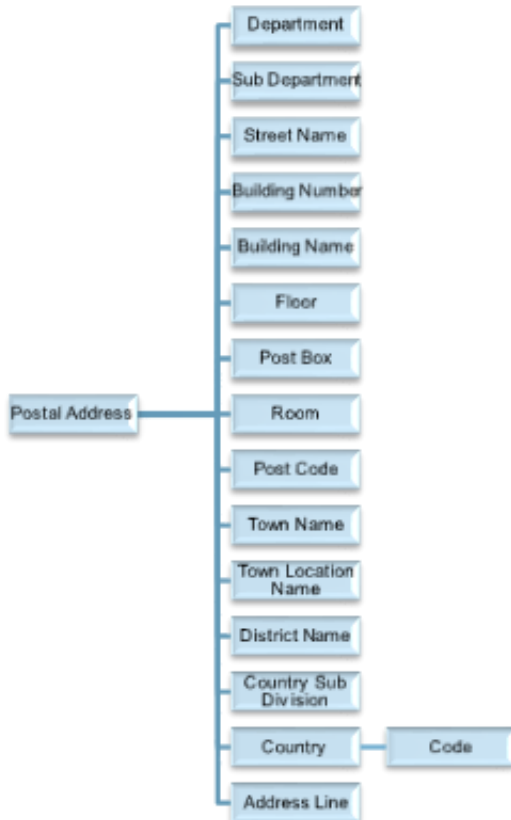

Information used to identify a Debtor by a clearing system identifier.

The BIC which identifies the *Debtor*

Legal entity identifier of the financial institution.

Name by which the Agent is known

Nested element capturing either structured or unstructured *Debtor* address details

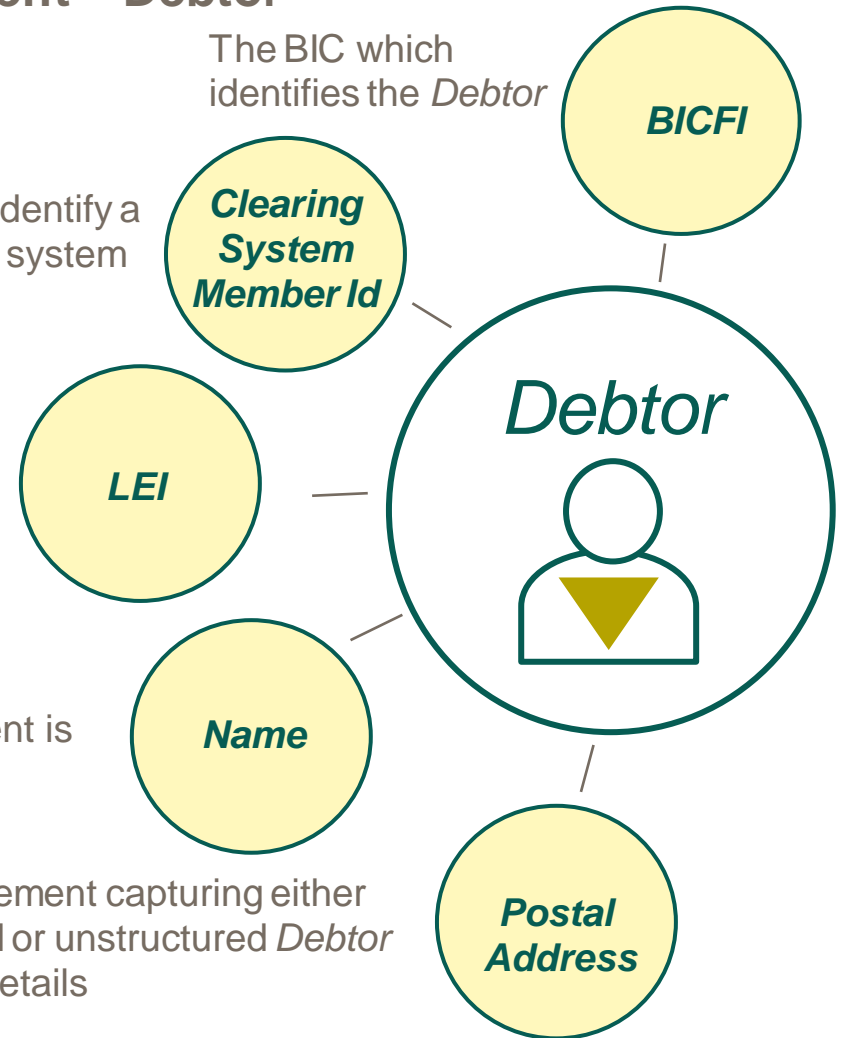

pacs.010 Financial Institution Direct Debit Margin Payment – Debtor Account

The Financial Institution Direct Debit message **Debtor Account** also provides an number of optional nested element to identify the account for which debit and credit entries have been made.

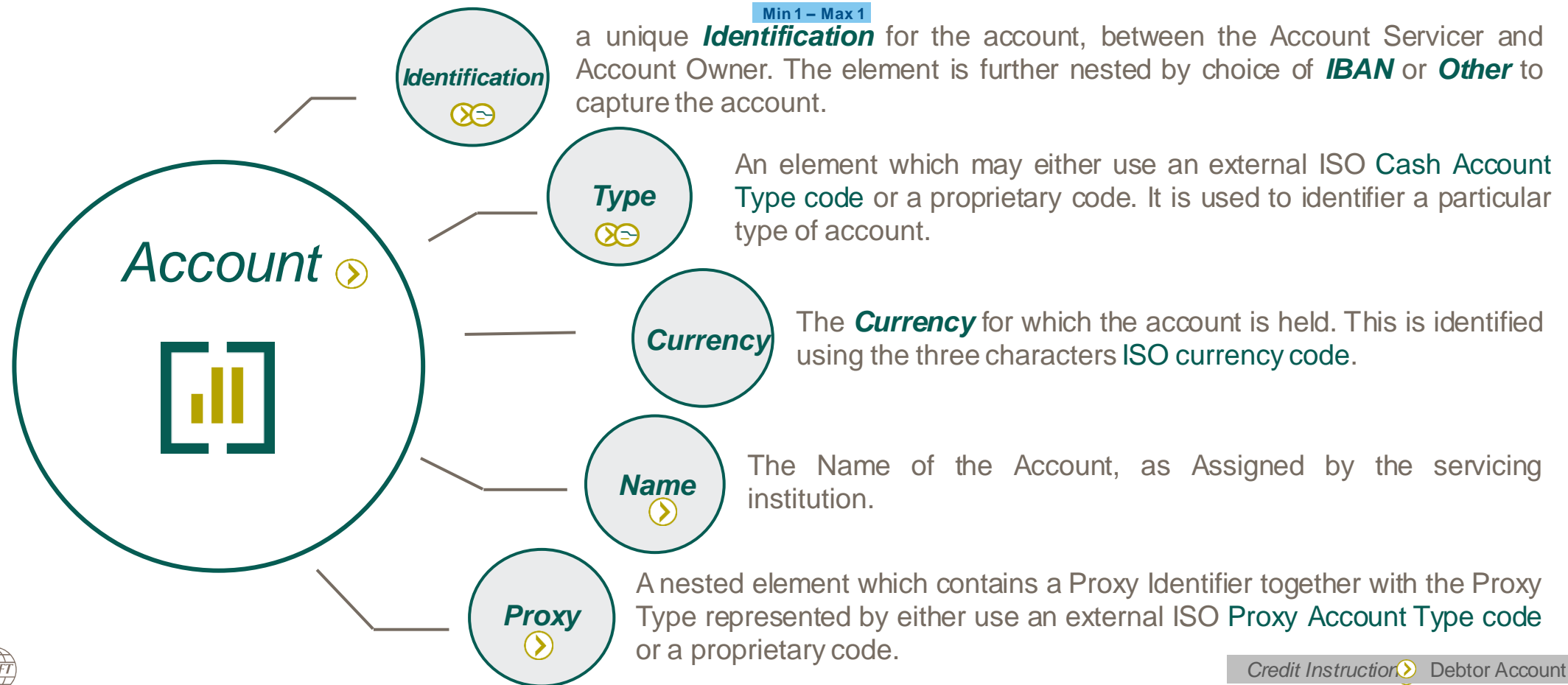

pacs.010 Financial Institution Direct Debit Margin Payment – Debtor Agent and Debtor Agent Account



Min 0 – Max 1

The **Debtor Agent** is a static role in the pacs messages. This agent maintain a relationship with their customer, the **Debtor**. Like the pacs.009 the Debtor Agent is optional, which cover the scenario where the Debtor and Creditor (as Financial Institutions) maintain a direct Nostro/Vostro account relationship, or where the Debtor Agent maintain the account of both the Debtor and Creditor.



Min 0 – Max 1

Where the **Debtor Agent** is utilised the **Debtor Agent Account** may optionally be used to capture the account of the Debtor Agent with the Agent immediate after them in the transaction chain (the Agent Serving their account)
This would only apply where the message includes a **Debtor Agent**, however CBPRplus does not recommend to use this element unless mandated within a community or bilaterally agreed.

Credit Instruction

Debtor Agent

Debtor Agent Account



pac.010 Financial Institution Direct Debit Margin Payment – Instruction For Debtor Agent

The ***Instruction for Debtor Agent*** elements within the pac.010 Financial Institution Direct Debit optionally provides information related to the processing of the direct debit instruction.



Min 0 – Max 1

The ***Instruction for Debtor Agent*** element offers a occurrence of free format information.

The use of this element should be **bilaterally** agreed with the *Debtor Agent* to maximize the ability to Straight Through Process the instruction.

paces.010 Financial Institution Direct Debit Margin Payment – Purpose

Min 0 – Max 1

The **Purpose** elements within the paces.010 Financial Institution Direct Debit capture the reason for the payment transaction which would result from a successful direct debit. This element may either use an external ISO **Purpose code** or a proprietary code.

The purpose is used by the capture the nature of the payment e.g. **CCPC** CCP Cleared Initial Margin and should not be confused with Regulatory Reporting codes.



The externalised Purpose code set is classified by the purpose, for example commercial, for which the numerous codes within the classification are each described by Name and Definition.

For example:

OTCD is classified within the Collateral categorisation, with the *Name* **OTC Derivatives** described as a **Cash collateral related to over-the-counter (OTC) Derivatives** - in general for example contracts which are traded and privately negotiated.

pacs.010 Financial Institution Direct Debit Margin Payment – Remittance Information

The optional **Remittance Information** element within the pacs.010 Financial Institution Direct Debit is nested to provide **Unstructured** information related to payment.

Min 0 – Max 1

Remittance Information enable the matching/reconciliation of an entry that the payment is intended to settle

Min 0 – Max 1

The **Unstructured** sub element captures free format *Remittance Information* which is restricted in CBPR+ to 140 characters to ensure backward compatibility with the legacy MT message during coexistence.



Note: like the pacs.009 *Remittance Information* can only be captured in an *Unstructured* element.

Remittance Information is however a dedicated element used both within the pacs and camt reporting messages, whereby this information can travel end-to-end using ISO 20022.

Credit Instruction > Remittance Information ✓

Unstructured

Index of pacs.010 Use Cases

Use case should be considered as a principal example whereby use case may be cross referenced e.g. a use case involving a Market Infrastructure can apply the Market Infrastructure legs to other use cases.

Financial Institution Direct Debit

Use Case p.10.2.1 - High Level Payment Of A Financial Institution Direct Debit (pacs.010)

Use Case p.10.2.2 - High Level Rejection Of A Financial Institution Direct Debit (pacs.010)

High Level Payment Of A Financial Institution Direct Debit Margin Payment (pacs.010)

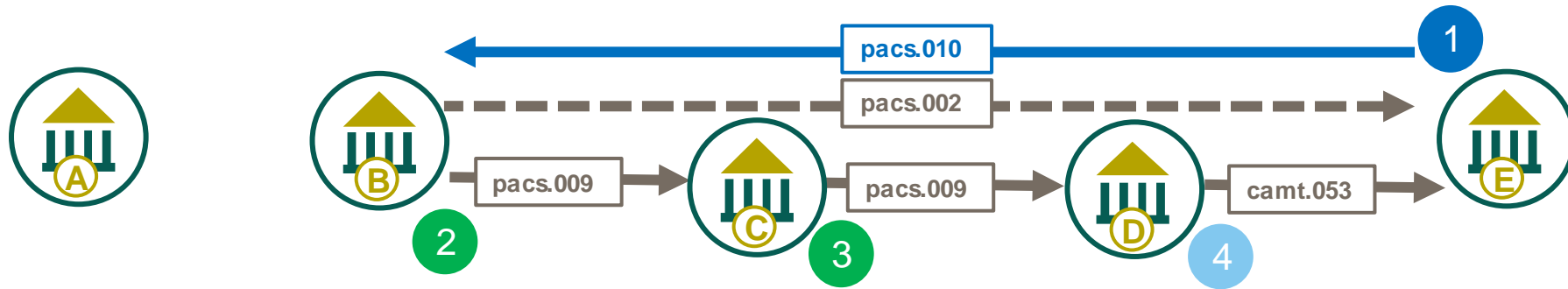

1

Agent E initiates a Direct Debit instruction to debit Agent A's account

2

Debtor Agent (B) initiates a serial payment towards the Creditor Agent (E) using Agents B & C as intermediaries

3

Agent C processes the payment on Agent D

4

Agent D credits the account of the Creditor (Agent E), and may optionally provide a notification e.g. credit notification in addition to an account statement (camt.053)

High Level Rejection Of A Financial Institution Direct Debit Margin Payment (pacs.010)

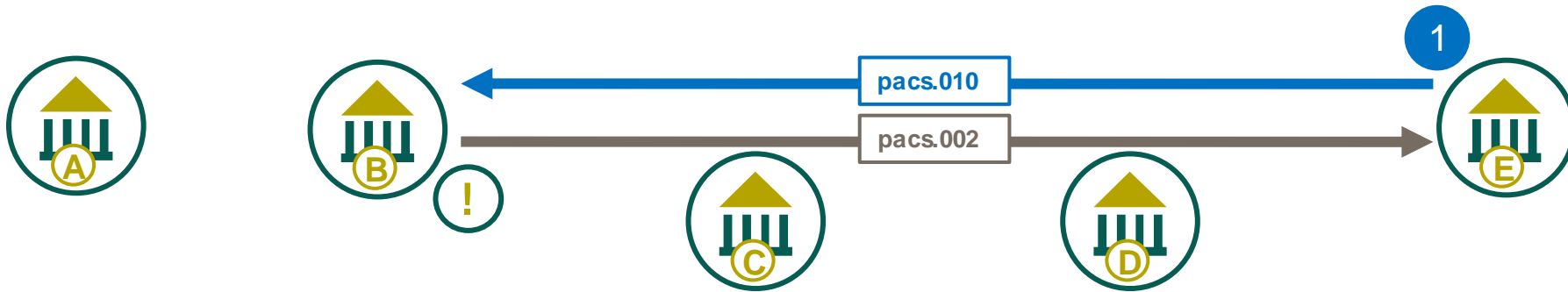

1

Agent D initiates a Direct Debit instruction to debit Agent A's account

!

Debtor Agent (B) rejects the instruction, using a pacs.002, as no mandate agreement is in place.

pacs.003



Financial Institution to Financial Institution Customer Direct Debit



pac.003 FI to FI Customer Direct Debit

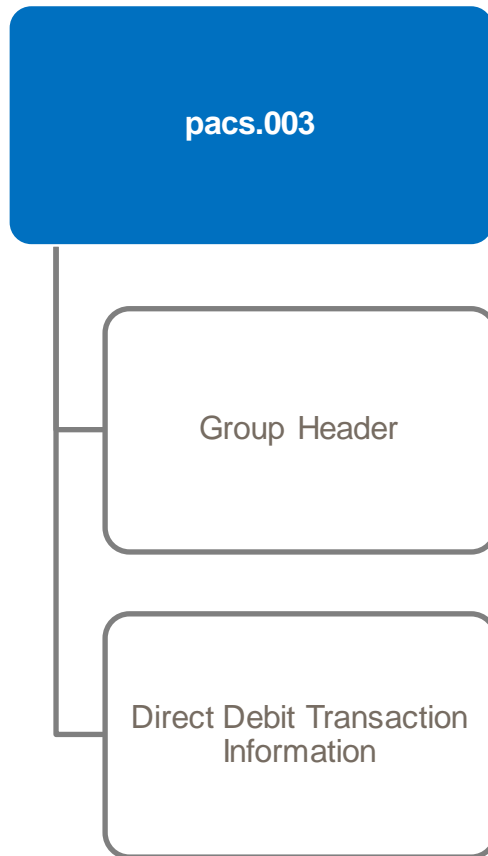

The pac.003 has two core sets of nested elements:

- **Group Header** which contains a set of characteristics that relates to all individual transaction
- **Direct Debit Transaction Information** which contains elements providing information specific to the individual direct debit transaction.



Payment messages in a many-to-many payment are considered as a single transaction.

High Level serial message flow

pac.s.003

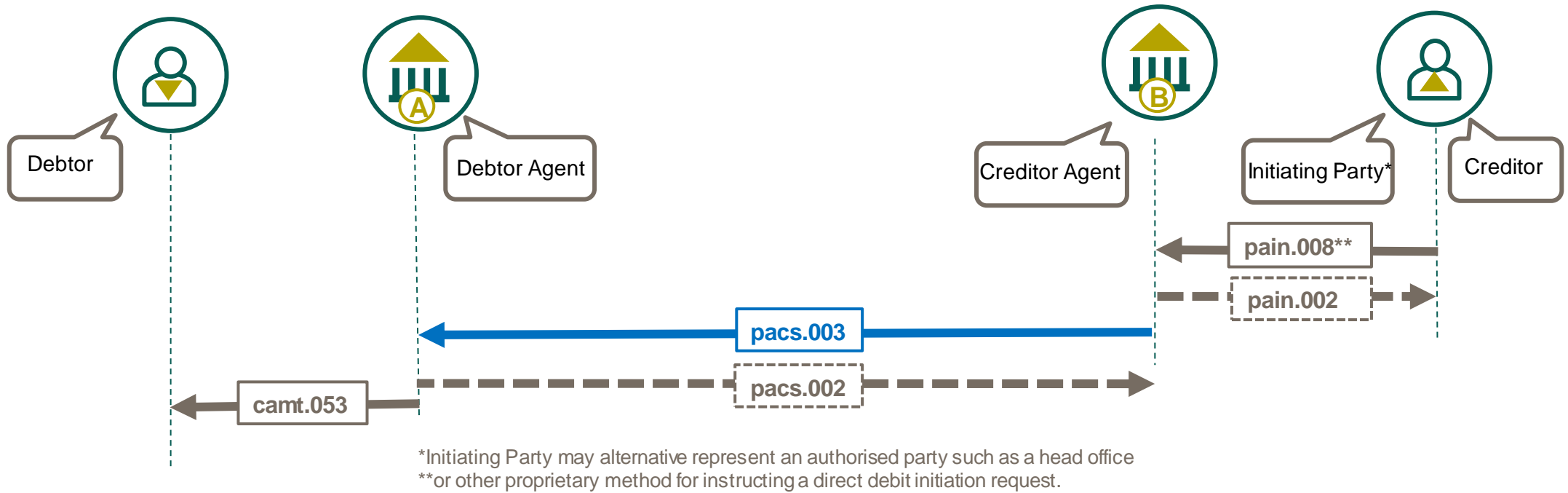

The Financial Institution To Financial Institution Customer Direct Debit message is sent by the Creditor Agent to the Debtor Agent, directly or through other agents and/or a payment clearing and settlement system. It is used to collect funds from a Debtor account for a Creditor, whereby one or both of these Parties are non-Financial Institutions.



*Noting in CGI-MP pain.008 may also be sent by the Initiating Party/Creditor directly to the Creditor Agent which is outside of the scope of CBPR+.

Group Header



pac.003 FI to FI Customer Direct Debit – Message Identification

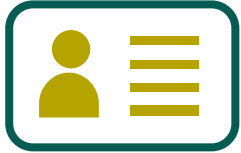

Min 1 – Max 1

Each ISO 20022 payment message has a **Message Identification** element, located in the Group Header. This **35 character** identifier is a point-to-point reference used to unambiguously identify the message.

For Payment Clearing and Settlement (pac) messages the Message Identification has no exact equivalent in the legacy MT payment message. However, the Sender's Reference (Field 20) could be considered a similar comparison where a pac message contains a single Transaction.



Each transaction's *Direct Debit Transaction Information* contains a variety of nested *Payment Identification* elements to capture reference related to the individual transaction such as a UETR (Unique End-to-end Transaction Reference)

Group Header ➤ Message Identification

pacs.003 FI to FI Customer Direct Debit – Creation DateTime

Min 1 – Max 1

The pacs.003 message **Creation Date** captures the date and time which the message was created.

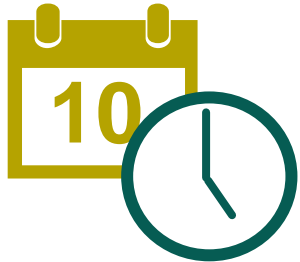

CBPR+ usage guidelines mandate the time zone that the time represents as an offset against Universal Time Coordinated (UTC):

Local time with UTC offset `YYYY-MM-DDThh:mm:ss.sss+/-hh:mm`

- For example: `2002-10-10T12:00:00-05:00` (noon/midday on 10 October 2002, Central Daylight Savings Time as well as Eastern Standard Time in the U.S.)



All CBPR+ time elements need offset against UTC. Milliseconds are optional.

Group Header ➤ Creation Date Time

pac.003 FI to FI Customer Direct Debit – Number of Transactions

Min 1 – Max 1

The pac.003 message ***Number of Transactions*** captures the number of individual transaction contained within the message.

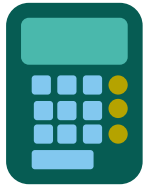

The number of transactions in CBPR+ payment usage guidelines is fixed to 1.



Single transactions in the CBPR+ payment usage guidelines enable a transaction to be managed and unlocks highly automated, frictionless, instant payments, supporting the next generation of innovation.

Group Header ➤ *Number of Transactions*

pac.003 FI to FI Customer Direct Debit – Settlement Information

Min 1 – Max 1

The pac.003 **Settlement Method** element within the Group Header **Settlement Information**, includes one of the embedded codes to indicate how the payment message will be settled.

The **Settlement Method** element in the pac.003 allows a choice of an embedded code.

INDA indicate this Customer Direct Debit will be settled by the Instructed Agent (as the Account Servicing Institution) The account held at the Instructed Agent may captured in the dedicated **Settlement Account** element.



INGA indicate this Customer Direct Debit has already been settled by the Instructing Agent, who has credited the Account they service for the Instructed Agent (as an Account Owner). The account held by the Instructed Agent with the Instructing Agent may captured in the dedicated **Settlement Account** element.



Settlement Method code **CLRG** is not part of CBPR+ specifications but instead used in Market Infrastructure specification



In the context of customer direct debit, INDA is a logical choice for the settlement with the customer because the INDA is the agent that owns the account of the Debtor, and the debit must be made first.



pacs.003 FI to FI Customer Direct Debit – Settlement Account

The pacs.003 message **Settlement Account** is a nested element as part of **Settlement Information**, this element identifies information related to an account used to settle the direct debit instruction.

Min 0 – Max 1

The **Settlement Account** identifies the account details maintained at the account servicing institution (Agent responsible for the settlement of the instruction as indicated in the **Settlement Method**)



Min 1 – Max 1 Identification identifies the account maintained at the Debtor Agent (Account Servicing Institution)

Min 0 – Max 1 Type uses the external Cash Account Type code list to identify the type of account

Min 0 – Max 1 Currency identifies the currency if the account

Min 0 – Max 1 Name identifies the name of the account as assigned by the Account Servicing Institution

Min 0 – Max 1 Proxy captures an alternative identification of the account number such as an email address. This element has further nested **Type** which is a choice of external code list or proprietary code and **Identification** which are both mandatory where the Proxy element is used.

Direct Debit Transaction Information



pacs.003 FI to FI Customer Direct Debit – Payment Identification

Min 1 – Max 1

The pacs message **Payment Identification** provides a set of elements to identify the payment, of which several are mandatory elements

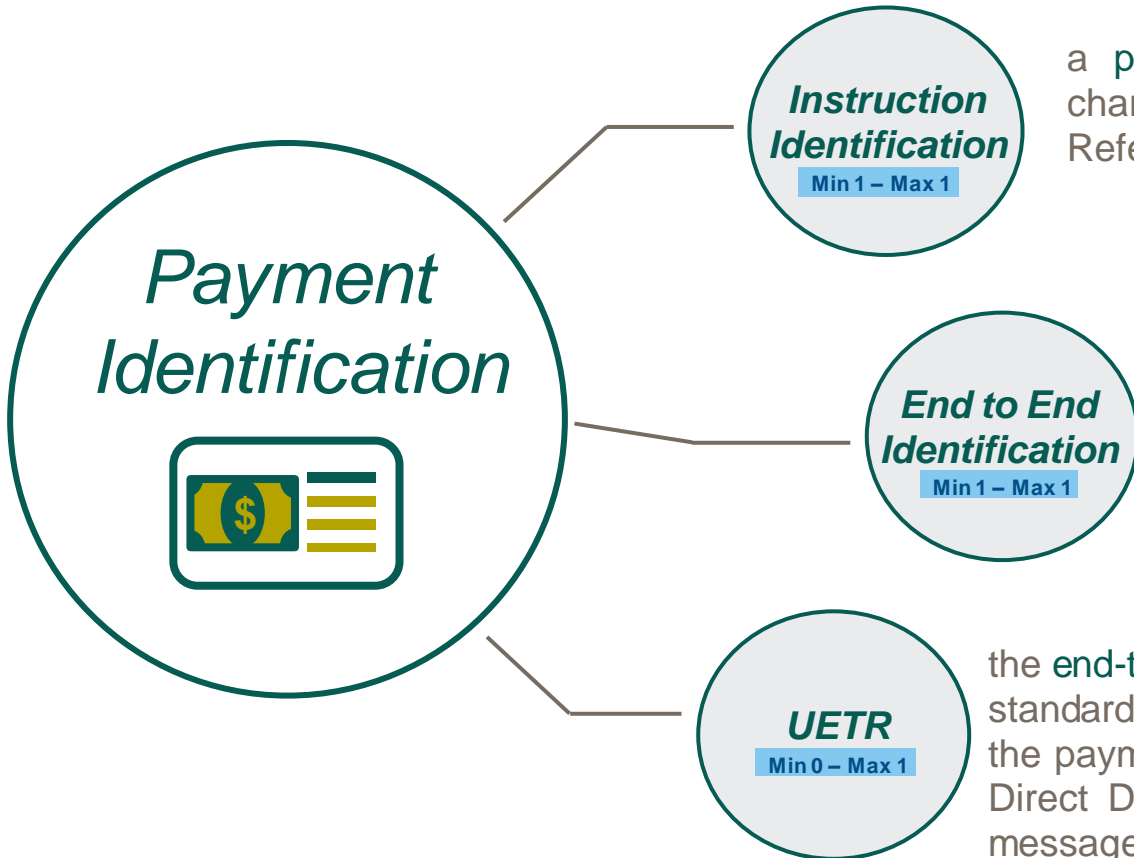

a **point-to-point reference** restricted in CBPR+ to 16 character and directly comparable with the Sender's Reference (Field 20) of the legacy MT payment message.

an **end-to-end reference** provided by the *Creditor* which must be passed unchanged throughout the payment and reported back to the Creditor.



note: if the Creditor has not provide an end-to-end identifier, the *Creditor Agent* may populate "NOTPROVIDED" to comply the mandatory need of this element.

the **end-to-end Transaction Reference** created using the UUIDv4 standard. This reference must be passed unchanged throughout the payment, it may also be created by the Creditor within their Direct Debit Initiation request, and also included in reporting messages.



pac003 FI to FI Customer Direct Debit – Payment Identification (continued)

The pac003 message **Payment Identification** ^{Min 1 – Max 1} also provides a set of optional elements to identify the direct debit transaction.

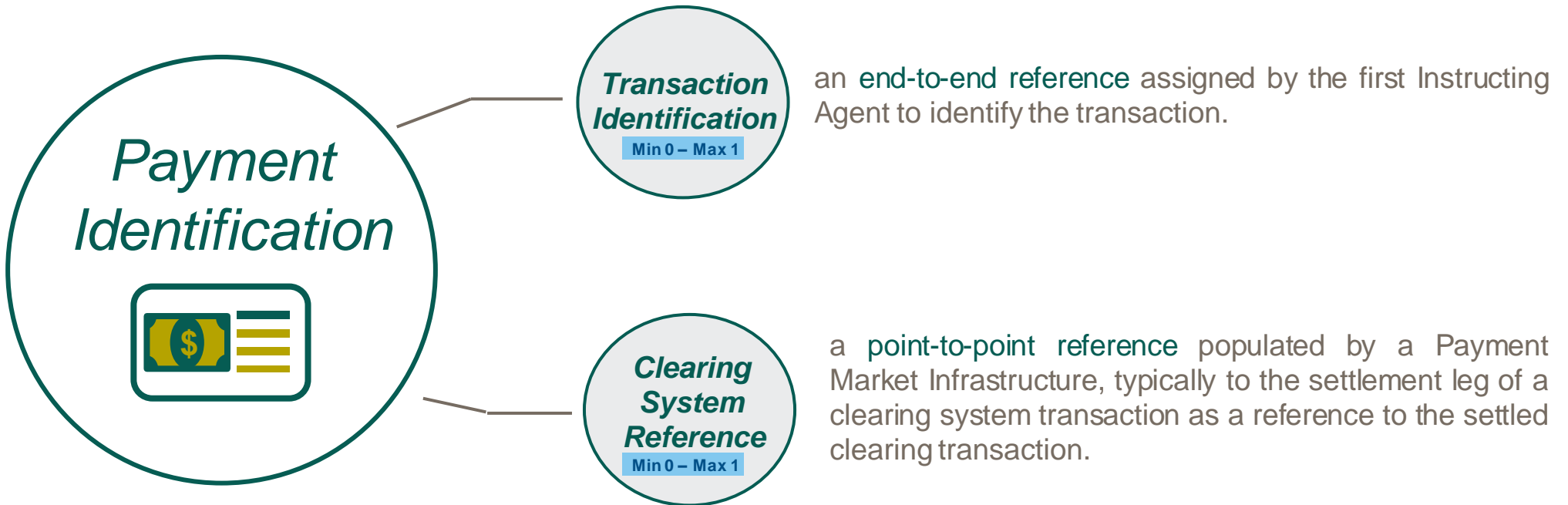

pacs.003 FI to FI Customer Direct Debit – Payment Type Information

Min 0 – Max 1

The pacs message **Payment Type Information** provides a set of optional elements where the payment type can be described.

a choice of imbedded codes representing the urgency considered by the Instructing Agent, this point-to-point information may be used by the Instructed Agent to differentiate the processing priority.

a choice of imbedded codes representing the clearing channel to be used to process direct debits.

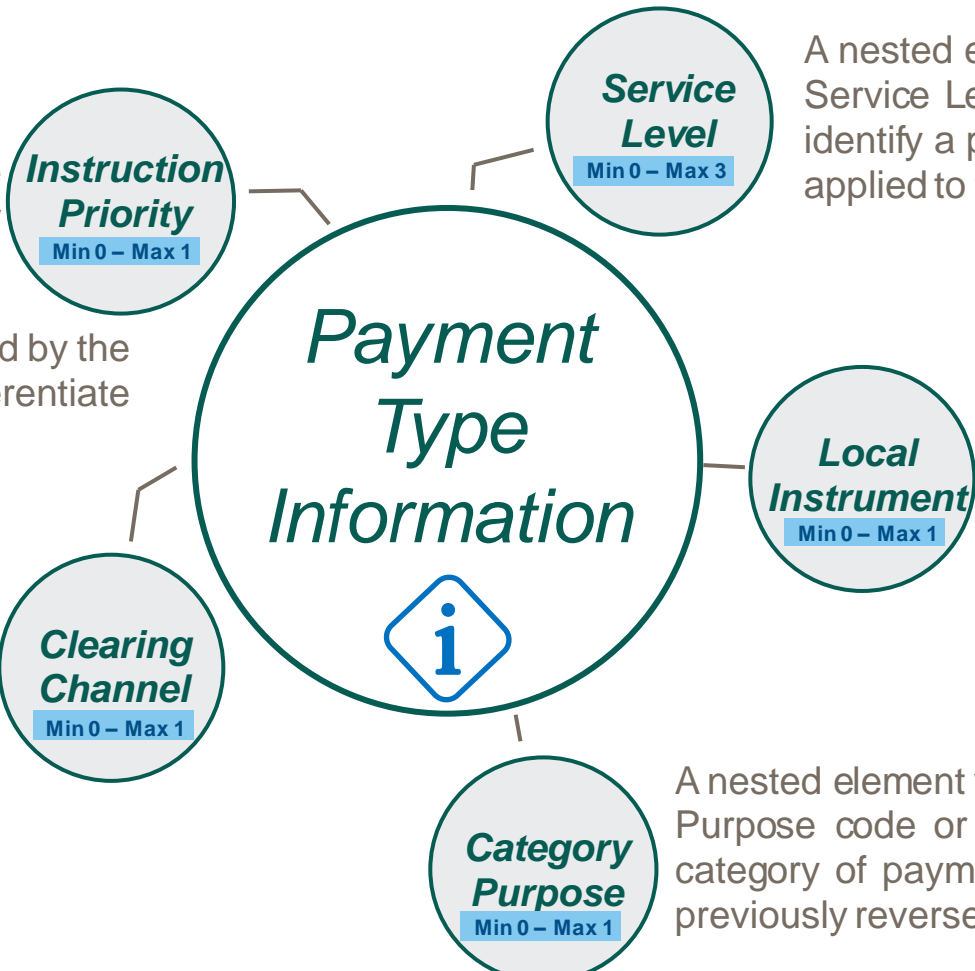

A nested element which may either use an external ISO Service Level code* or a proprietary code. It is used to identify a particular agreed service level which should be applied to the payment.

A nested element which may either use an external ISO Local Instrument code or a proprietary code. It is used to identify the type of payment local instrument such as a Standing Order.

 Note: the ISO instrument codes are registered by specific community group (captured in the code list)

A nested element which may either use an external ISO Category Purpose code or a proprietary code. It is used to identify the category of payment. For example, RPRES means to re-present previously reversed or returned direct debit transaction.



*note - where a service level is not bilaterally agreed, it may be ignored.

pacs.003 FI to FI Customer Direct Debit – Interbank Settlement Amount and Date

The pacs.003 message has two key elements to capture the amount of the Credit Transfer, **Interbank Settlement Amount** and **Interbank Settlement Date**.

Min 1 – Max 1

Min 1 – Max 1



Interbank Settlement Amount

A mandated currency amount moved between the *Instructing Agent* and the *Instructed Agent*. This therefore is the point-to-point currency amount exchanged, comparable with the MT Field 32B

Interbank Settlement Date

A mandated date on which the *Interbank Settlement* should be executed between the *Instructing Agent* and the *Instructed Agent*. This therefore is the value date comparable with the MT Field 30



Note: the relationship between Interbank Settlement Amount and Instructed Amount is an important one. Instructed Amount relates to the amount Instructed to be debited from the Debtor's account and only need to be captured in the Instructed Amount where the Interbank Settlement Amount is not the same currency amount.



Direct Debit Transaction Information

➤ Interbank Settlement Amount

➤ Instructed Amount

pac.003 FI to FI Customer Direct Debit – Settlement Priority & Settlement Time Indication

The pac.003 message has two optional elements to capture the information related to the settlement of the instructions.

Min 0 – Max 1



The **Settlement Priority** provides an optional choice of embedded codes to indicate the instruction's settlement priority from the perspective of the Instructing Agent. This point-to-point information may be used by the Instructed Agent to identify the priority associated with the **Settlement Method** and should not be confused with the **Instruction Priority**.



Note: where **Settlement Priority** of the pac.003 is 'URGT' (Urgent) means the highest priority possible to process the direct debit settlement and the amount of money becomes available to the Creditor Agent.

Min 0 – Max 1



The **Settlement Time Indication** optionally captures the time settlement occurred at a transaction administrator such as a Market Infrastructure.

This DateTime can be captured in two nested elements, **Debit Date Time** and **Credit Date Time**.



Direct Debit Transaction Information

Settlement Priority

Settlement Time Indication

pac.003 FI to FI Customer Direct Debit – Instructed Amount and Exchange Rate



Min 0 – Max 1

The **Instructed Amount** captures currency and amount instructed by the Creditor. This conditional element is required when the **Interbank Settlement Amount** is not the same currency and/or amount as originally instructed by the *Creditor*. For example, a charge is taken, or the transactions is converted to another currency. This element is comparable with the legacy Field 33B.

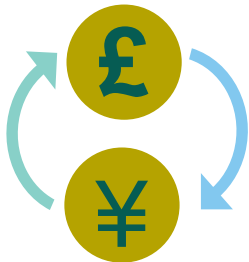

Min 0 – Max 1

The **Exchange Rate** captures the factor (rate) used to convert an amount from one currency into another. This reflects the currency pair price at which one currency was bought with another currency.



Note: a number of Cross Element Rules exist which relate to the **Instructed Amount** element. For example, if the **Instructed Amount** is present and the currency is different from the currency in **Interbank Settlement Amount**, then **Exchange Rate** must be present.



Direct Debit Transaction Information

Instructed Amount

Exchange Rate

pacs.003 FI to FI Customer Direct Debit – Charge Bearer

Min 1 – Max 1

The mandated **Charge Bearer** element uses an embedded code that is used to specify which party/parties would bear any charges associated with processing the payment transaction. This element is comparable with MT Field 71A ‘Details of Charges’

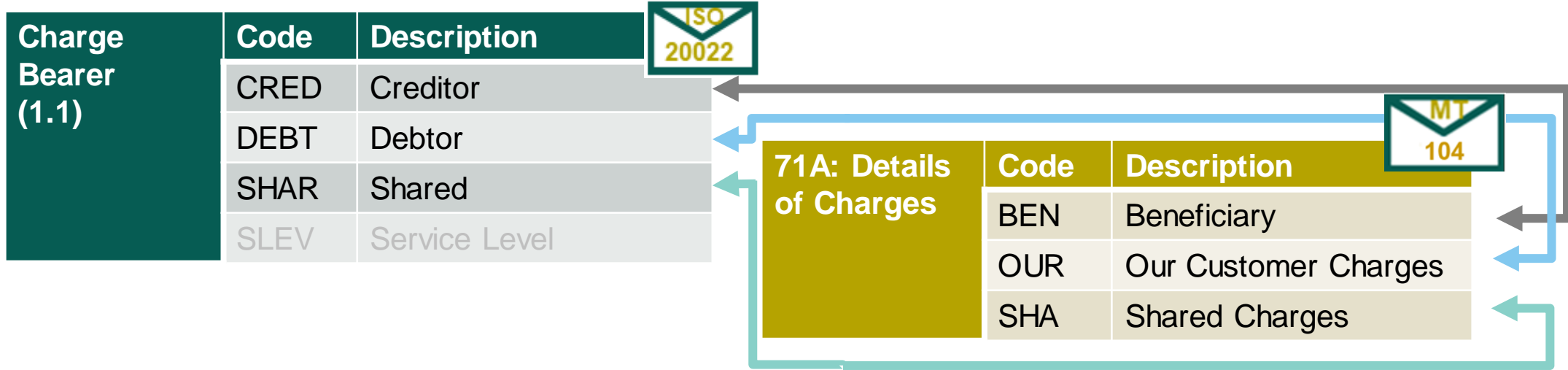

Note: SLEV is removed from CBPR+ usage guideline specifications.



pac.003 FI to FI Customer Direct Debit – Charges Information

Min 0 – Max *

Min 1 – Max 1

The **Charges Information** element provides information on the charges to be paid by the **Charge Bearer**. This element is comparable with MT Fields: 71F ‘Senders Charges’ and 71G ‘Receiver’s Charges’

Charge Information (0.*)	Amount	
	Currency	
	Agent	BICFI
		Name
Structured Postal Address		

In addition to the legacy MT message the pac.003 *Charge Information* mandate the *Agent*, this represent the Agent for who the Charges are either; due (pre-paid charges) or has taken a charge (deduct from the transaction)



CBPR+ best practice recommends the use of the structured Agent BIC.

As the **Charges Information** element is repetitive it can capture charges related to previous legs of the payment transaction.



Note: As the *Charge Information* element has the capability to capture both charges deducted and charges included i.e. pre-paid charges, the use of the *Interbank Settlement Amount* and *Instructed Amount* elements play an important role.



pac.003 FI to FI Customer Direct Debit – Requested Collection Date

Min 1 – Max 1

The pac.003 message mandatory **Requested Collection Date** element, captures the date on which the creditor requests that the amount of money is to be collected from the debtor.



It is defined by **ISO Date** expressed in the **YYYY-MM-DD format**.



Direct Debit Transaction Information

Requested Collection Date

paces.003 FI to FI Customer Direct Debit – Direct Debit Transaction



Min 0 – Max 1

The pacs.003 **Direct Debit Transaction** component provides information specific to the direct debit mandate.

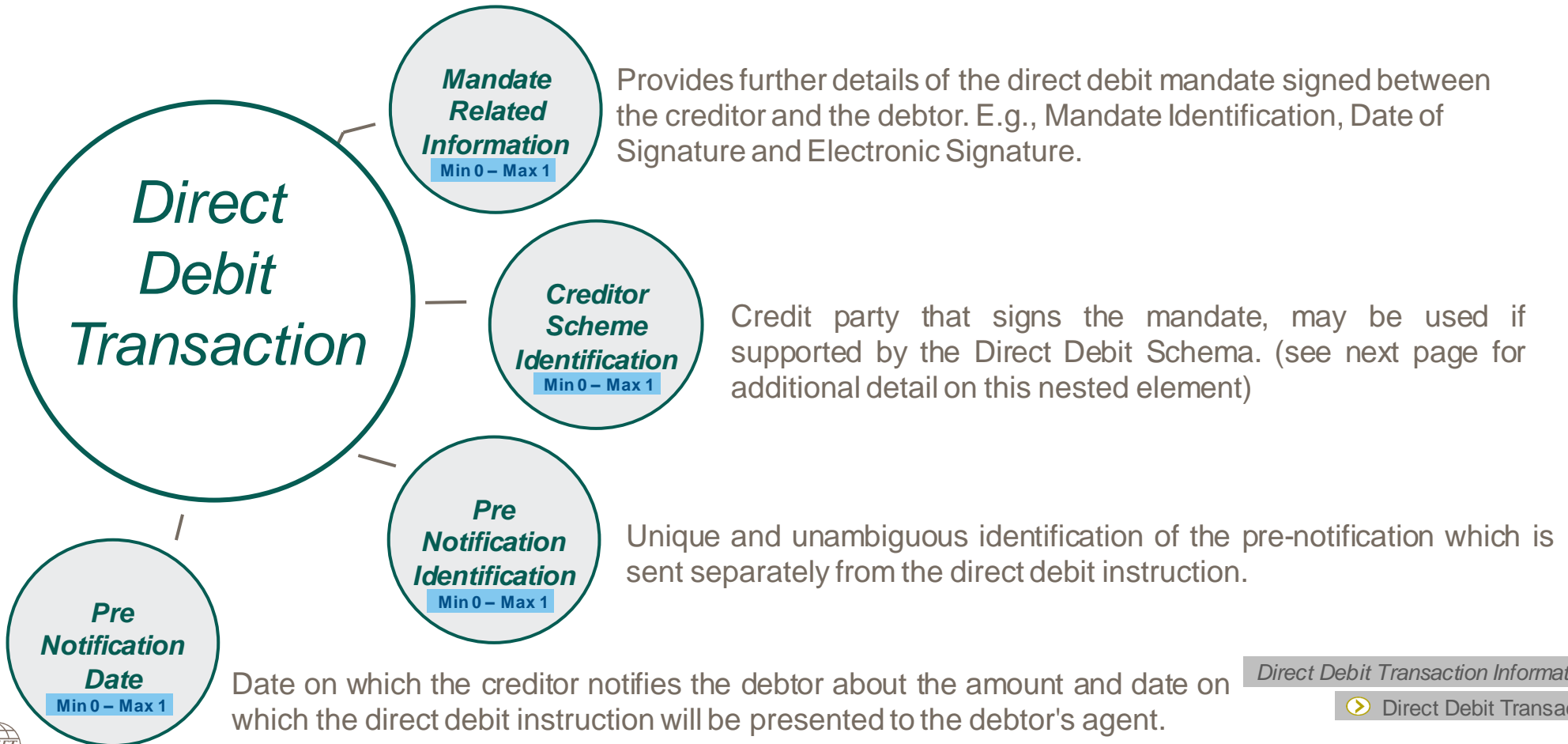

pac.003 FI to FI Customer Direct Debit – Creditor Scheme Identification

Min 0 – Max 1

The **Creditor Scheme Identification** element within the pac.003 message optionally provides information related to the credit party that signs the mandate who is different from the Creditor.



The **Creditor Scheme Identification** element offers the following options:

- Name
- Postal Address: Not used often
- Identification
- Country of Residence
- Contact Details



CGI-MP: recommends the use of Creditor Scheme Identification only if supported by the Direct Debit Scheme.



Direct Debit Transaction Information 

 Direct Debit Transaction

 Creditor Scheme Identification

pacs.003 FI to FI Customer Direct Debit – Creditor

The ISO 20022 pacs messages describe the party credited for a transaction as the **Creditor**. The **Creditor** sub elements describe the *Creditor* in greater detail. Min 1 – Max 1

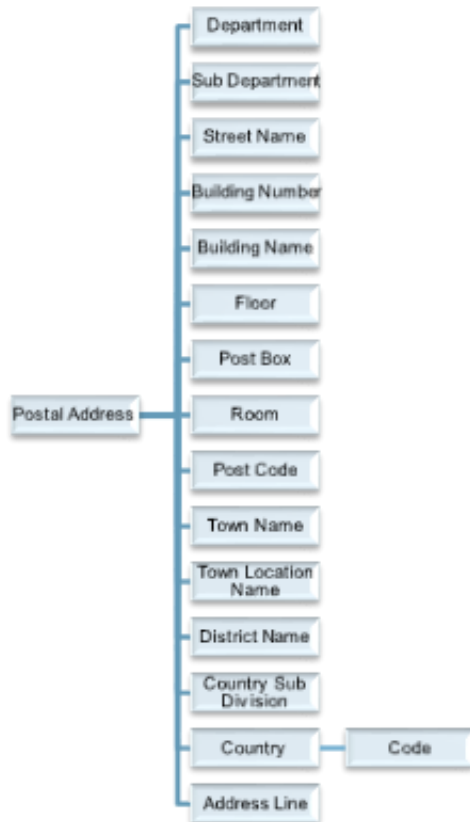

Nested element capturing either structured or unstructured **Creditor** address details

Nested element capturing the various types of identifiers for the party e.g. BIC, LEI etc.

Mandatory **Name**, where a BIC identifier is not provided, by which the party is known

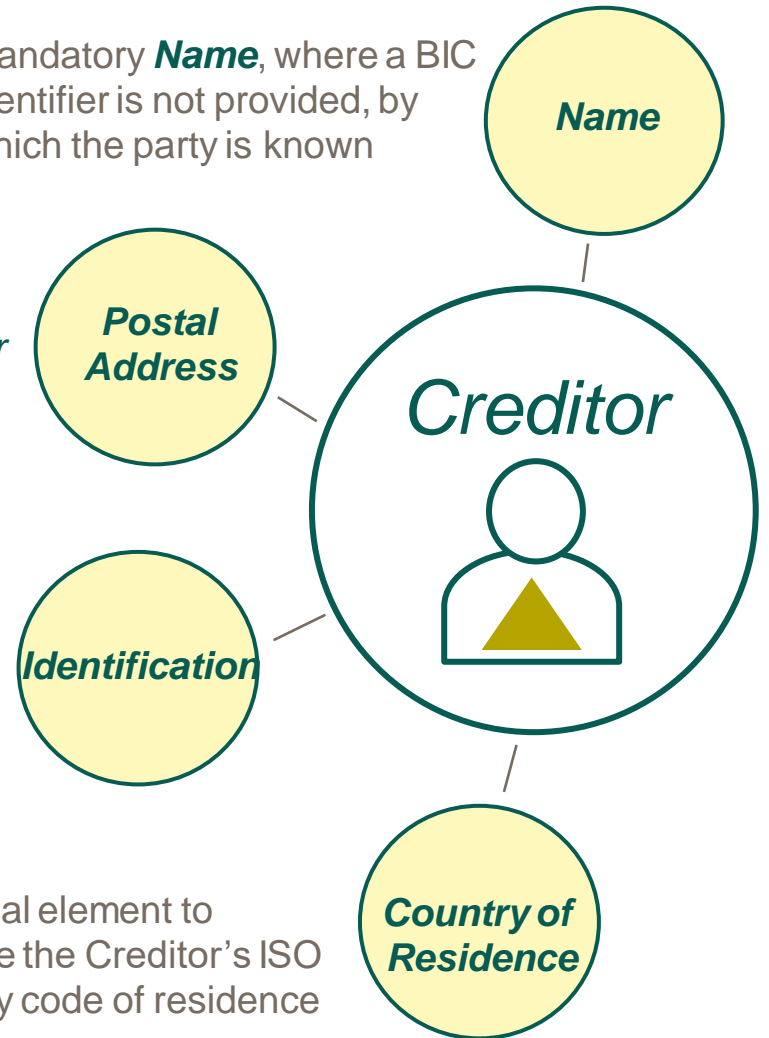

Optional element to capture the Creditor's ISO country code of residence



pac.003 FI to FI Customer Direct Debit – Creditor Account

Min 0 – Max 1

The pac.003 **Creditor Account** is used to capture the account information for which a credit entry is intended to be applied to the Creditor's account, which are also reflected in their account Statement.

The **Creditor Account** uses a variety of nested elements to capture information related to the account.



Min 1 – Max 1 Identification identifies the account maintained at the Creditor Agent (Account Servicing Institution)

Min 0 – Max 1 Type uses the external Cash Account Type code list to identify the type of account

Min 0 – Max 1 Currency identifies the currency of the account

Min 0 – Max 1 Name identifies the name of the account as assigned by the Creditor Agent (Account Servicing Institution)

Min 0 – Max 1 Proxy captures an alternative identification of the account number such as an email address. This element has further nested **Type** which is a choice of external code list or proprietary code and **Identification** which are both mandatory where the Proxy element is used.

pac.003 FI to FI Customer Direct Debit – Debtor Agent and Creditor Agent

Min 1 – Max 1

Min 1 – Max 1

The **Debtor Agent** and **Creditor Agent** are static roles in the pac.003 FI to FI Customer Direct Debit. These agent maintain a relationship with their customers; the *Debtor* and *Creditor*.



Note: Although the **Debtor Agent**, **Creditor Agent**, **Debtor** and **Creditor** all maintain static roles in the pac messages, the description of these parties change in the reporting messages (camt) where the Debtor Agent and Creditor Agent become the Statement Account Servicer and the Debtor and Creditor become the Statement Account Owner. This will be explored further in the camt Cash Management Reporting section.

Direct Debit Transaction Information 

 Debtor Agent

 Creditor Agent

pac.003 FI to FI Customer Direct Debit – Debtor Agent Account and Creditor Agent Account

Min 0 – Max 1

The pac.003 **Debtor Agent Account** and **Creditor Agent Account** are used to capture the account information related to these Agents. The nature of this element implies there is an Agent or Agent in between the Debtor Agent and Creditor Agent in the direct debit transaction.

The **Debtor Agent Account** and **Creditor Agent Account** use a variety of nested elements to capture information related to the account.



Min 1 – Max 1

Identification identifies the account maintained at the Account Servicing Institution

Min 0 – Max 1

Type uses the external Cash Account Type code list to identify the type of account

Min 0 – Max 1

Currency identifies the currency of the account

Min 0 – Max 1

Name identifies the name of the account as assigned by the Account Servicing Institution

Min 0 – Max 1

Proxy captures an alternative identification of the account number such as an email address. This element has further nested **Type** which is a choice of external code list or proprietary code and **Identification** which are both mandatory where the Proxy element is used.



Debtor Agent and Creditor Agent are a Financial Institution, therefore the nested elements **Name** and **Proxy** are unlikely to be used.



pacs.003 FI to FI Customer Direct Debit – Ultimate Debtor and Ultimate Creditor

The pacs.003 message introduces ultimate parties to the FI to FI Customer Direct Debit message. The **Ultimate Creditor** element should not be confused with an **Initiating Party** who may send a direct debit initiation request on behalf of the Creditor. (see dedication section on *Initiating Party*)

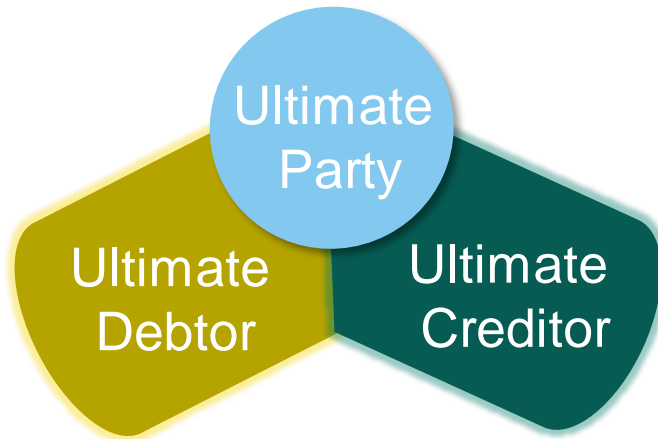

- CBPR+ premise is that an **Ultimate Debtor** ^{Min 0 – Max 1} has no financial regulated direct account relationship with the corresponding *Debtor*.
- CBPR+ premise is that an **Ultimate Creditor** ^{Min 0 – Max 1} has no financial regulated direct account relationship with the corresponding *Creditor*.

An account is often used a term to recognise an ongoing customer relationship. Non Agent payment provider are typically not bound by the same regulatory oversight as an Agent (Financial Institution). They would therefore be classed as a Party to a payment, where the account relationship with their customer would classify their customer as an Ultimate (Debtor or Creditor depending on the payment scenario)

Note: *Ultimate Debtor* and *Ultimate Creditor* are removed from the pacs.010 Financial Institution Direct Debit.

Direct Debit Transaction Information

Ultimate Creditor

Ultimate Debtor



pacs.003 FI to FI Customer Direct Debit – Initiating Party

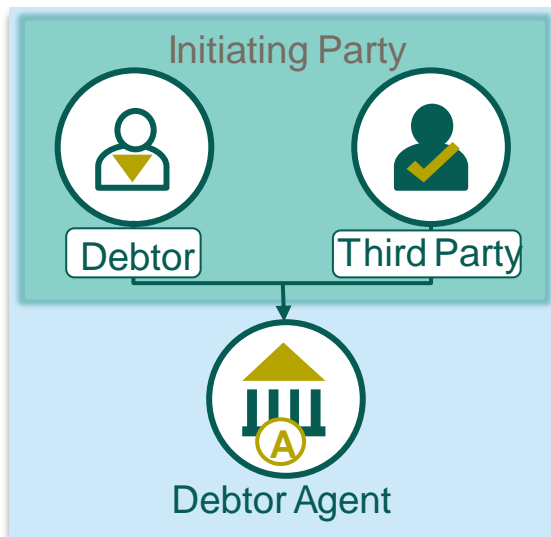

Min 0 – Max 1

The **Initiating Party** of a direct debit is often the **Creditor** themselves and therefore this optional element is not necessary. More often the *Initiating Party* is a third party providing direct debit collection services on behalf of the *Creditor* (often referred to as a Third Party Provider) whereby the *Creditor* maintains an account with the Creditor Agent but the Third Party Provider has authority to initiate collection on behalf of the *Creditor*. This is distinctly different from an Ultimate Party (such as *Ultimate Creditor*) who instructs the *Creditor* to initiate a collection on their behalf.

Min 1 – Max 1



In the context of a Direct Debit (pacs.003) or Request to Payment (pain.013) the *Initiating Party* is often the *Creditor*, however the same context of a Third Party Provider can exist where the third party is responsible for collecting funds on behalf of the *Creditor*.

pac.003 FI to FI Customer Direct Debit – Instructed and Instructing Agents

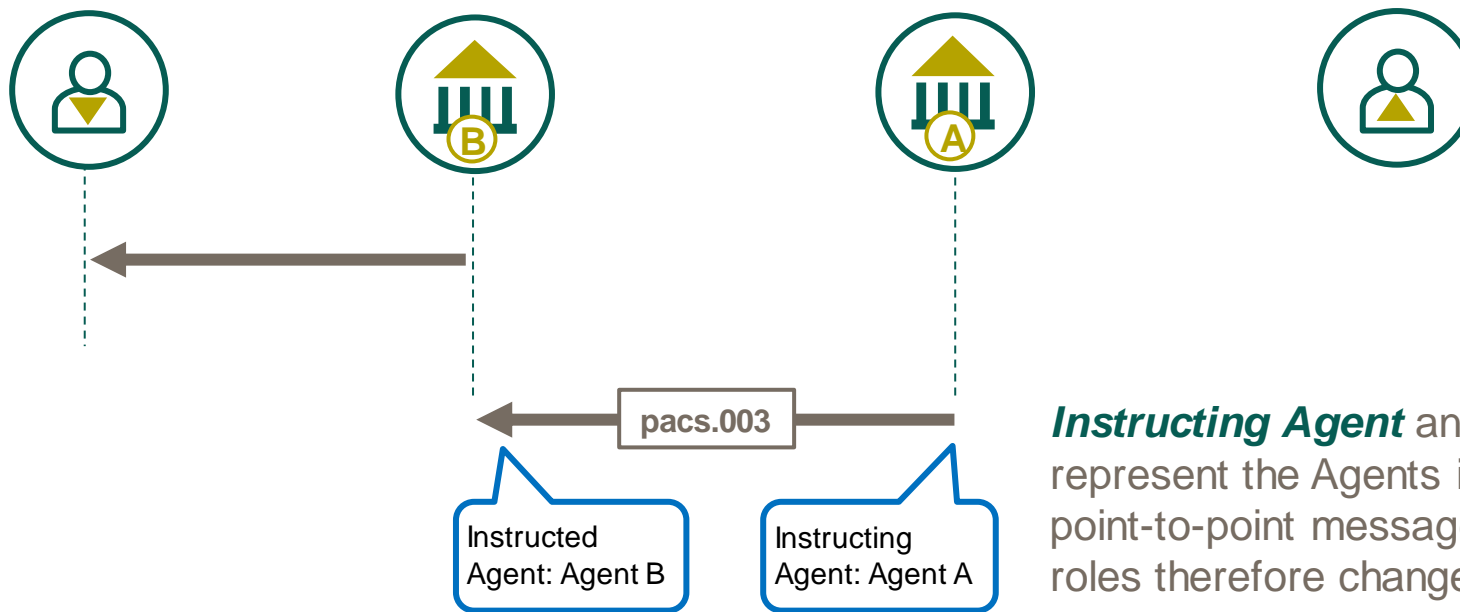

Instructing Agent and **Instructed Agent** represent the Agents involved in the pac.003 point-to-point message exchange. These roles therefore change on each payment leg.



Instructing Agent and **Instructed Agent** elements are required in all pac.003 messages and are available in the **Direct Debit Transaction Information**

Direct Debit Transaction Information

Instructing Agent

Instructed Agent



paces.003 FI to FI Customer Direct Debit – Intermediary Agents

The pacs message can capture up to 3 Intermediary Agents, which play a dynamic role in the payment between the Debtor Agent and Creditor Agent.

Min 0 – Max 1

The **Intermediary Agent 1** captures the first Intermediary Agent between the Debtor Agent and Creditor Agent for who the Instructed Agent attempt to instruct the payment on to. This optional element is comparable with the Field 56a in the legacy FIN message.



Min 0 – Max 1

The **Intermediary Agent 1 Account** captured the account related to this Intermediary Agent, with the Instructed Agent. This element can be compared to the Party Identifier of the legacy Field 56a.

Min 0 – Max 1

The **Intermediary Agent 2** captures the second Intermediary Agent between the Intermediary Agent 1 and the Creditor Agent. This optional element has not comparable field in the legacy FIN message.



Min 0 – Max 1

The **Intermediary Agent 2 Account** captured the account related to this Intermediary Agent, with the Intermediary Agent 1. This optional element has not comparable field in the legacy FIN message.

Min 0 – Max 1

The **Intermediary Agent 3** captures the third Intermediary Agent between the Intermediary Agent 2 and the Creditor Agent. This optional element has not comparable field in the legacy FIN message.



Min 0 – Max 1

The **Intermediary Agent 3 Account** captured the account related to this Intermediary Agent, with the Intermediary Agent 2. This optional element has not comparable field in the legacy FIN message.



pac003 FI to FI Customer Direct Debit – Debtor

The ISO 2022 pac003 messages describe the party debited for a transaction as the **Debtor**. The **Debtor** sub elements describe the **Debtor** in greater detail. Min 1 – Max 1

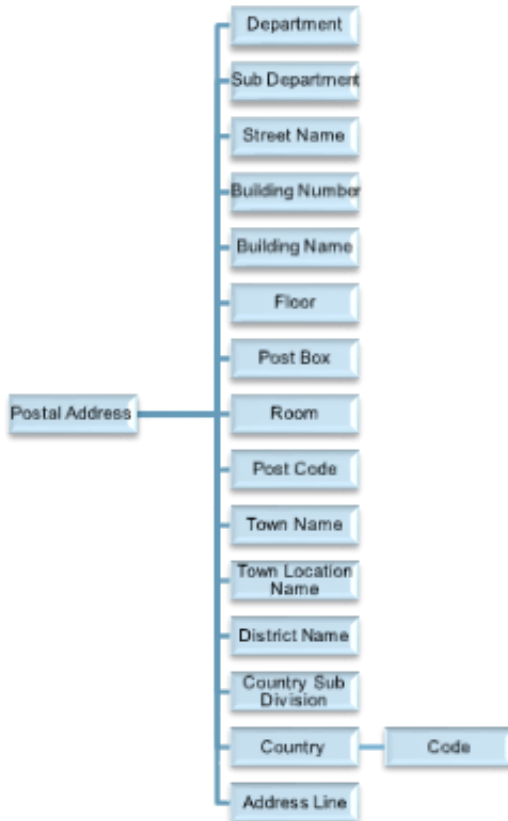

Nested element capturing either structured or unstructured **Debtor** address details

Nested element capturing the various types of identifiers for the party e.g. BIC, LEI etc.

Mandatory **Name** (where a BIC identifier is not provided) by which the party is known

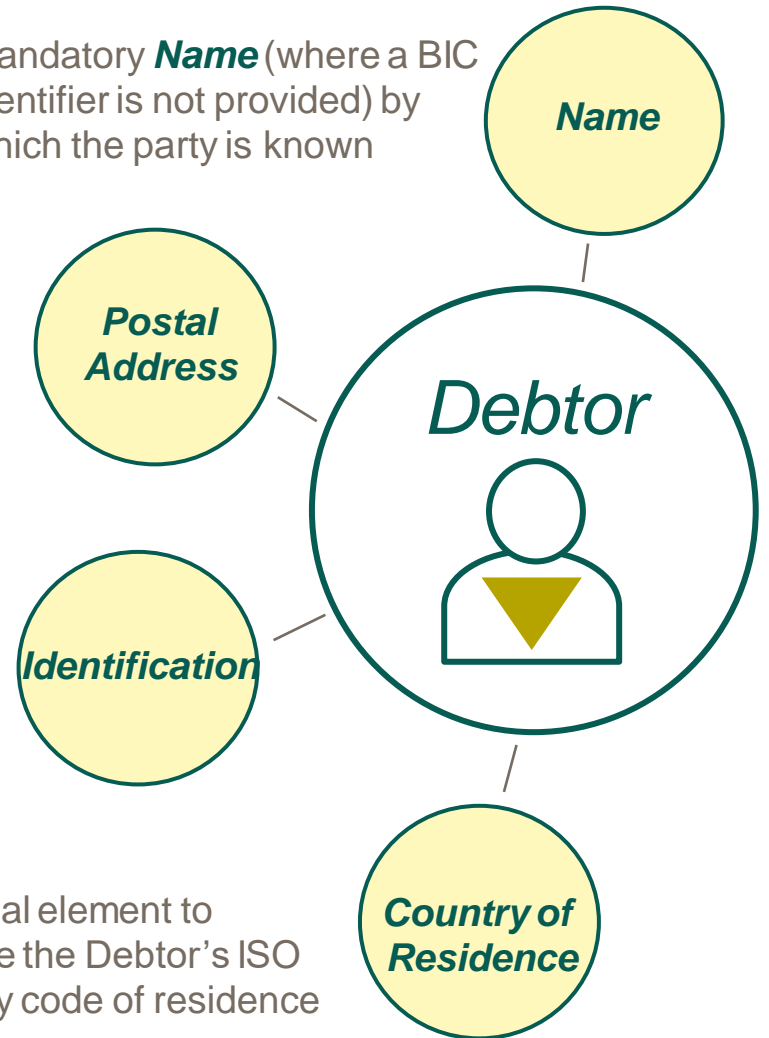

Optional element to capture the Debtor's ISO country code of residence



pac.003 FI to FI Customer Direct Debit – Debtor Account

Min 1 – Max 1

The pac.003 mandatory **Debtor Account** is used to capture the account information for which debit entry is/has been applied to the Debtor's account, which are also reflected in their account Statement.

The **Debtor Account** uses a variety of nested elements to capture information related to the account.



Min 1 – Max 1 Identification identifies the account maintained at the Debtor Agent (Account Servicing Institution)

Min 0 – Max 1 Type uses the external Cash Account Type code list to identify the type of account

Min 0 – Max 1 Currency identifies the currency of the account

Min 0 – Max 1 Name identifies the name of the account as assigned by the Debtor Agent (Account Servicing Institution)

Min 0 – Max 1 Proxy captures an alternative identification of the account number such as an email address. This element has further nested **Type** which is a choice of external code list or proprietary code and **Identification** which are both mandatory where the Proxy element is used.

pacs.003 FI to FI Customer Direct Debit – High Level Use Case involving an Ultimate Debtor

A children sports clubs (Creditor), collects its monthly membership fee via direct debit, against the parents (Debtor) of one of its members (Ultimate Debtor).

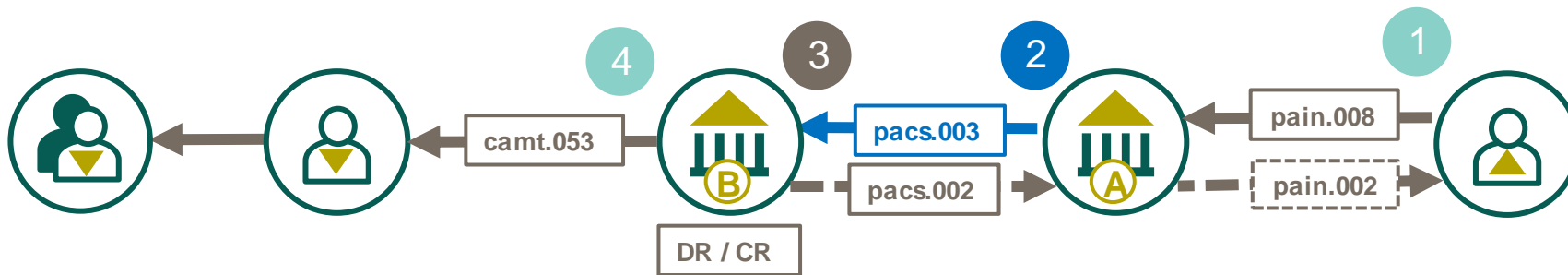

1

Sports club, the Creditor who has a mandate* with the Debtor, initiates a direct debit instruction by sending a pain.008 message to their bank, Creditor Agent (A).

2

Agent A, the Creditor Agent, initiates a direct debit instruction by sending a pacs.003 message to the Debtor Agent (B).

3

Debtor Agent (B) debits the account of the Debtor, credits the account of the Creditor Agent and confirms the direct debit status using a pain.002.

4

Debtor, receives a statement from their bank confirming the monthly Debt Debit, for their child (Ultimate Debtors) sports club membership fee, has debited either account,



*Mandate: the Creditor has a mandate, the right to collect funds from the Debtor's account which is pre-defined for debits.

pac.003 FI to FI Customer Direct Debit – Purpose

Min 0 – Max 1

The **Purpose** element within the pac.003 FI to FI Customer Direct Debit captures the reason for the direct debit transaction which may either use an external ISO **Purpose code** or a proprietary code.

The purpose is used to capture the nature of the payment e.g. **IVPT** Invoice Payment, **FEES** Payment of Fees etc. and should not be confused with Regulatory Reporting codes. By definition this information is typically defined by the Creditor.



The externalised Purpose code set is classified by the purpose, for example commercial, for which the numerous codes within the classification are each described by Name and Definition.

For example, **LOAR** is classified within the Finance categorisation, with the *Name* **Loan Repayment** described as a repayment of loan to lender.



Category Purpose also captures a high level purpose, which unlike **Purpose** is less granular but can trigger special processing e.g. Category Purpose code SALA 'Salary Payment' may trigger a reporting process which restricts sensitive data i.e., individual salary names.

Direct Debit Transaction Information 

 Purpose

pac.003 FI to FI Customer Direct Debit – Regulatory Reporting

Min 0 – Max 10

The **Regulatory Reporting** element within the pac.003 FI to FI Customer Direct Debit is nested to capture regulatory and statutory information needed to report to the appropriate authority/s.



Min 0 – Max 1

The **Debit Credit Reporting Indicator** utilises an embedded choice of code to indicate whether the regulatory reporting information applies to the:

- DEBT (debit)
- CRED (credit) or
- BOTH

Min 0 – Max 1

The **Authority** element captures the **Name** and **Country** code of the Authority/Entity requiring the regulatory reporting information.

Min 0 – Max *

The **Details** element provides the detail on the regulatory reporting information.

Direct Debit Transaction Information > Regulatory Reporting ✓

⊗ Debit Credit Reporting Indicator

> Authority

> Details

521

pac.003 FI to FI Customer Direct Debit – Related Remittance Information

Min 0 – Max 1

The **Related Remittance Information** element within the pac.003 FI to FI Customer Direct Debit is nested to provide information related to the handling of remittance information. This information is typically provided by the Creditor in the direct debit initiation request.

Min 0 – Max 1

The **Remittance Identification** captures a unique reference assigned by the initiating party of the collection to identify the remittance information sent separately from the direct debit instruction.

Min 0 – Max 2

The **Remittance Location Details** uses a set of nested elements to provide information on either the location of or the delivery of remittance information.

- **Method** requires a code from an embedded list to detail the method used to deliver the remittance advise information e.g. EMAL (email)
- **Electronic Address** provides an electronic address for which an agent is to send the remittance information to e.g. the email address. It may also reference a URL where remittance information may be deposited or retrieved.
- **Postal Address** provides the postal address to which an agent is to send the remittance information



Remittance advices are typically considered as a traditional value added service provided by the Creditor Agent to the Creditor, in order to facilitate reconciliation for the Creditor. By nature this element can travel end-to-end within the pain, pac.003 and camt reporting messages.

Remittance Information is a dedicated element used both within the pac.003 and camt reporting messages, whereby this information can travel end-to-end using ISO 20022. *Related Remittance Information* and *Remittance Information* are mutually exclusive (can't both be present)

Business examples are emerging where information is externalised using a URL repository solution.



Direct Debit Transaction Info  Related Remittance Information 

Remittance Identification 

 Remittance Location Details

pacs.003 FI to FI Customer Direct Debit – Remittance Information

The optional **Remittance Information** element within the pacs.003 FI to FI Customer Direct Debit is nested to provide either **Structured** or **Unstructured** information related to direct debit collections, such as invoices.

Min 0 – Max 1

Remittance Information enable the matching/reconciliation of an entry that the direct debit is intended to settle



Min 0 – Max 1

The **Unstructured** sub element captures free format *Remittance Information* which is restricted in CBPR+ to 140 characters to ensure backward compatibility with the legacy MT message during coexistence.

Min 0 – Max *

The **Structured** element is nested capturing rich structured *Remittance Information*, and is unlimited in its multiplicity, but must not exceed 9,000 characters of business information (does not include the xml element identification)

The use of this nested element should be **bilaterally/multilaterally** agreed, to ensure end-to-end transportation of this data.



Related Remittance Information and Remittance Information are mutually exclusive (can't both be present)

Direct Debit Transaction Info > Remittance Information ✓

> Structured

Unstructured



pacs.003 FI to FI Customer Direct Debit – Structured Remittance Information

The bilaterally/multilaterally agreed **Remittance Information** which is **Structured** must not exceed 9,000 characters of business content (i.e. the information). This nested element is used to capture a variety of structured remittance information.



example of *Structured* invoice information

The **Creditor Remittance Information** is provided to the **Creditor** in the Cash Management Reporting messages' Remittance Information component, for example, the camt.053 Bank to Customer Statement.

Structured			
Reference Document Information	<RfrdDocInf>	xml tag business information	
Type	<Tp>		
Code Or Proprietary	<CdOrPrtry>		
Code	<Cd>		CINV
Number	<Nb>		A0000101
Related Date	<Dt>		2019-10-29



In this example Referred Document Information and its nested elements has multiplicity which support up to 9,000 character of information. Whereby this element can be repeated to include more coded information such as another invoice.

Direct Debit Transaction Information

Remittance Information

Structured

Index of pacs.003 Use Cases

Use case should be considered as a principal example whereby use case may be cross referenced e.g. a use case involving a Market Infrastructure can apply the Market Infrastructure legs to other use cases.

Serial Financial Institution to Financial Institution Customer Direct Debit

Use Case p.3.1.1 – High Level FI to FI Customer Direct Debit (pacs.003) successful settlement

Use Case p.3.1.2 – High Level FI to FI Customer Direct Debit (pacs.003) unsuccessful settlement

High Level FI to FI Customer Direct Debit (pacs.003) successful settlement

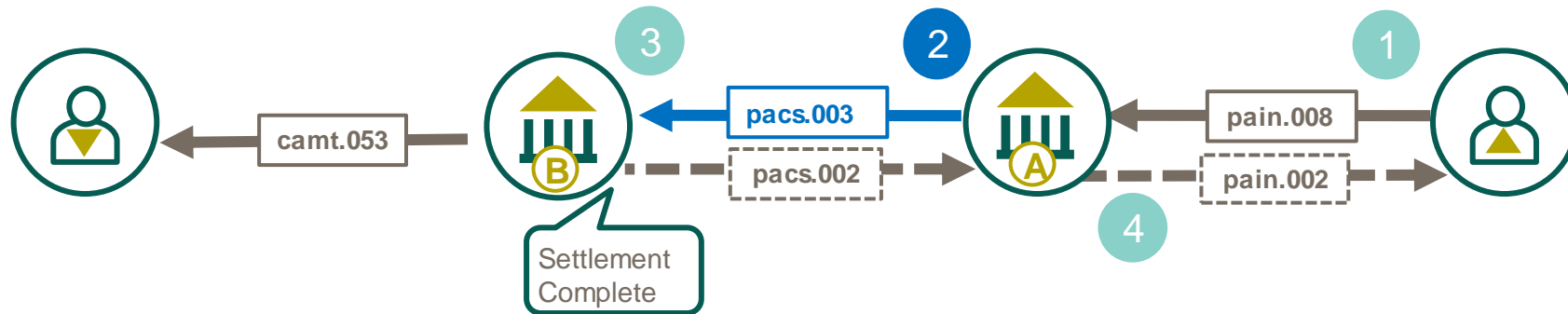

1 Creditor initiates a direct debit instruction to the Creditor Agent

2 Creditor Agent (A) initiates a direct debit collection by sending a pacs.003 message to the Debtor Agent with the settlement method "INDA"

3 The Debtor Agent debits the account of the Debtor, and may optionally provide a notification e.g. debit notification in addition to an account statement (camt.053). The Debtor Agent also provides a status update ACSC (accepted settlement completed) to the Creditor Agent.

4 Creditor Agent (A) relays the status ACSC (accepted settlement completed) to the Initiating Party, based upon a bilateral agreement

High Level FI to FI Customer Direct Debit (pacs.003) unsuccessful settlement

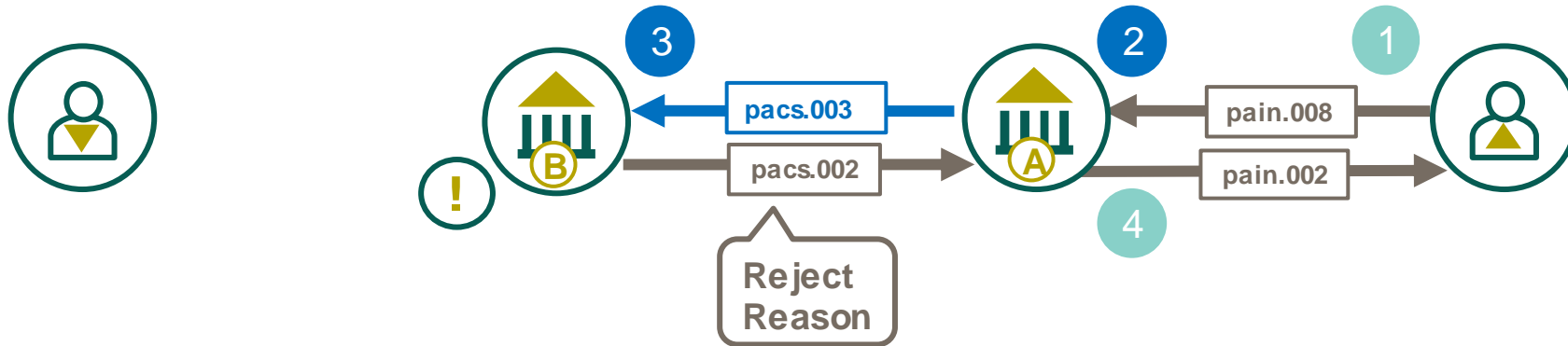

1 Creditor initiates a direct debit instruction to the Creditor Agent

2 Creditor Agent (A) initiates a direct debit collection by sending a pacs.003 message to the Debtor Agent with the settlement method "INDA"

3 The Debtor Agent fails to debit the account of the Debtor (e.g., account is closed). The Debtor Agent provides a status update RJCT (Rejected) with the rejection reason information.

4 Creditor Agent (A) relays the status RJCT (Rejected) to the Initiating Party with the rejection reason information

Cash Management Reporting (camt) messages



Cash Management Reporting - Messages index



Cash Management Reporting

[camt.052 - Bank to Customer Account Report](#)

[camt.053 - Bank to Customer Statement](#)

[camt.054 - Bank to Customer Debit Credit Notification](#)

[camt.057 – Notification To Receive](#)

[camt.058 – Notification To Receive Cancellation Advice](#)

[camt.060 – Account Report Request](#)

camt.052

Bank to Customer Account Report



camt.052 Bank to Customer Account Report

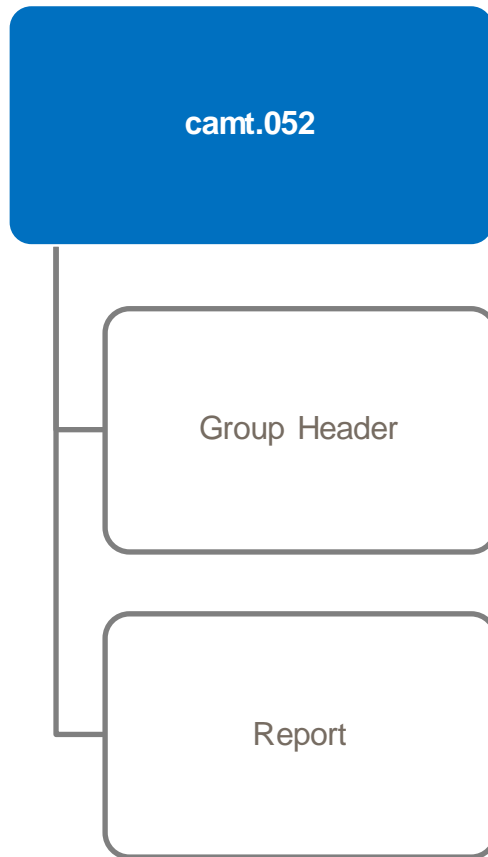

The *Bank To Customer Account Report* message is sent by the account servicer to an account owner or to a party authorised by the account owner to receive the message. It can be used to inform the account owner, or authorised party, of:

- entries reported to the account (Intraday Statement)
- account balance information (Account Balance Report)
- or both.

for a given point in time.



The Bank to Customer Account Report is restricted to a single account statements per InterAct message (100,000 bytes)
This message must be bilaterally agreed between the Account Servicing Institution and the Account owner, and is established by an RMA business profile.

High Level Bank to Customer Account Report (camt.052)

camt.052

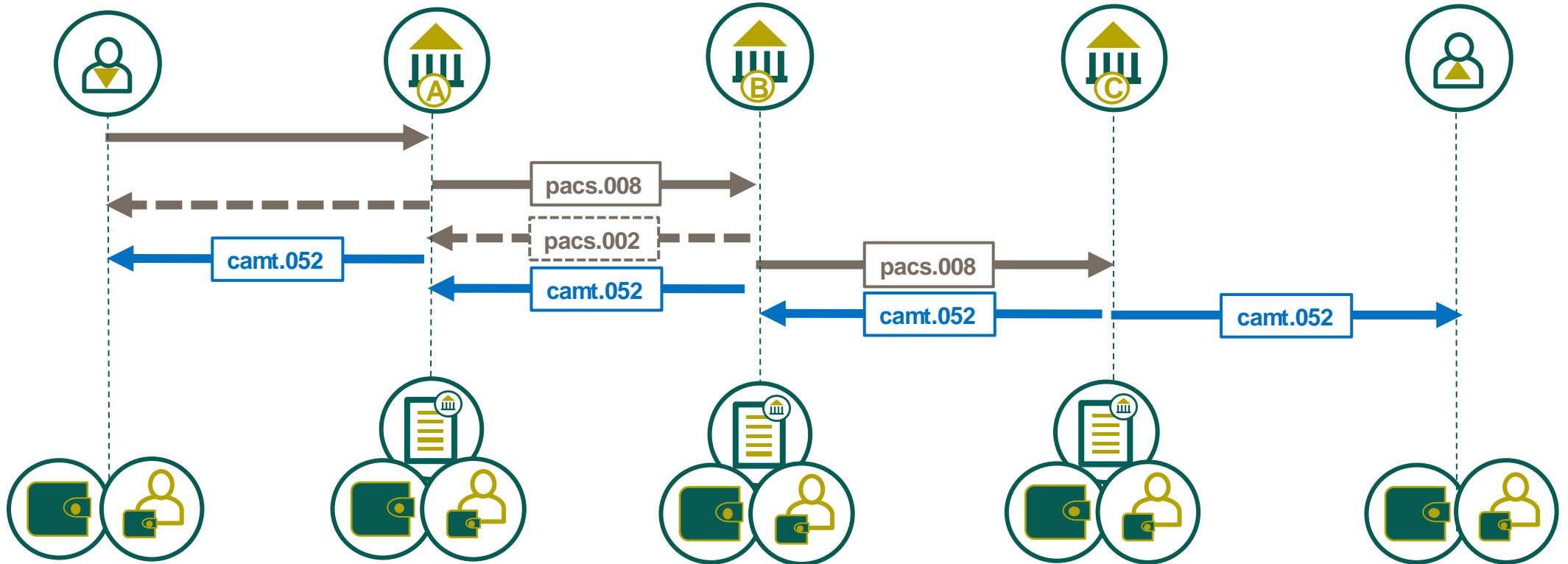

Role of the Creditor Agent and Creditor in the payment changes by description in the Bank to Customer Account Report message to Account Servicer and Account Owner. Whereby the report is send by the Account Servicer to the Account Owner and or authorised party. This message is used to inform the account owner, or authorised party, of the entries reported to the account, and/or to provide the owner with balance information on the account at a given point in time.

Group Header



camt.052 Bank to Customer Account Report - Message Identification



Each ISO 20022 cash management reporting message has a *Message Identification* element, located in the Group Header. This **35 character** identifier is a point-to-point reference used to unambiguously identify the message.

For Cash Management (camt) messages the *Message Identification* has no exact equivalent in the legacy MT Customer Statement message. However, the *Transaction Reference Number* (Field 20) could be considered a similar comparison.

Group Header ➤ Message Identification

camt.052 Bank to Customer Account Report – Creation DateTime

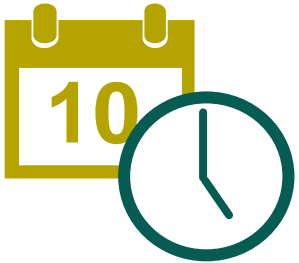

CBPR+ usage guidelines mandate the time zone that the time represents as an offset against Universal Time Coordinated (UTC):

Local time with UTC offset YYYY-MM-DDThh:mm:ss.sss+/-hh:mm

- For example: 2002-10-10T12:00:00-05:00 (noon/midday on 10 October 2002, Central Daylight Savings Time as well as Eastern Standard Time in the U.S.)



All CBPR+ time elements need offset against UTC. Milliseconds are optional.

Group Header ▶ Creation Date Time

camt.052 Bank to Customer Account Report – Message Recipient

Min 0 – Max 1

The Bank to Customer Account Report **Message Recipient** nested element provides details of the party authorised by the *Account Owner* to receive the Account Report.

This element **should only** be used to identify the *Message Recipient* when different from the account owner, which is implied by the usage of **COPY** in the *Copy Duplicate Indicator* within the nested **Statement** element.



Where **Message Recipient** is used the nested:

- **Name** Min 0 – Max 1
- **Postal Address** Min 0 – Max 1
- **Identification** Min 0 – Max 1
- **Contact Details** Min 0 – Max 1

may be used to capture information related to this party.

Group Header ▶ Message Recipient ▼

Name

▶ Postal Address

⊗ Identification

▶ Contact Details

536

camt.052 Bank to Customer Account Report – Original Business Query

The Bank to Customer Account Report **Original Business Query** ^{Min 0 – Max 1} element identifies a query to generate a report, for example a camt.060 Account Reporting Request.



Where **Original Business Query** is used the original **Message identification** ^{Min 1 – Max 1} (i.e., the message identification of the camt.060 message) is required. Original **Message Name identification** and Original **Creation Date Time** ^{Min 0 – Max 1} may also be provided. ^{Min 0 – Max 1}

Group Header ▶ Original Business Query ▼

Message Identification

Message Name Identification

Creation Date Time 537

camt.052 Bank to Customer Account Report – Additional Information

Min 0 – Max 1

The Bank to Customer Account Report **Additional Information** element represents further details related to the account statement.



In accordance to the usage in the camt.053 this element could be used to describe additional information to distinguish the different camt.052 usage i.e., where the report is only reporting an intraday balance, intraday entries or both. Unlike the camt.053 there is no recommended identification string to represent usage.



Additional Information is a textual element restricted in CBPR+ to 500 characters.

Group Header  Additional Information

Report



camt.052 Bank to Customer Account Report - Report

Min 1 – Max 1

The Bank to Customer Account Report **Report** element provides information related to an account, most typically associated with intraday account entries and or accounting balances (where entries have been processed on the account). The report element can be used to advise entries reported to the account (Intraday Statement), account balance information (Account Balance Report) or both.

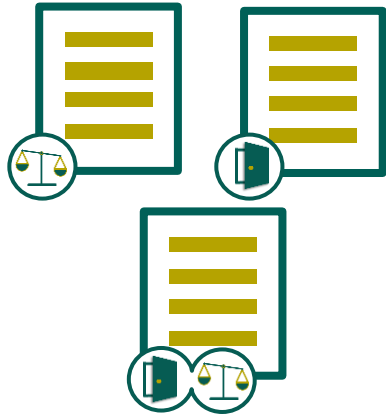

The *Report* element has been restricted to one account report. To report additional accounts to the Account Owner this would need to occur via a separate message in a similar way to the legacy MT 942.



It should also be noted the Account Report message is modelled identically to the Account Statement (camt.053) therefore where used as an intraday transaction report the content can be capture identically to the statement at the close of the business day, in the Account Statement (camt.053)

Report >

camt.052 Bank to Customer Account Report – Report sent over multiple messages

Similar to the legacy MT Intraday Reporting message (i.e., 942) the camt.052 Bank to Customer Account Report is constrained in CBPR+ by the FINplus service's message size. Consideration therefore need to be given (when reporting transactional information) to identifying; the **report order**, the **report correlation** and the **last report page**.

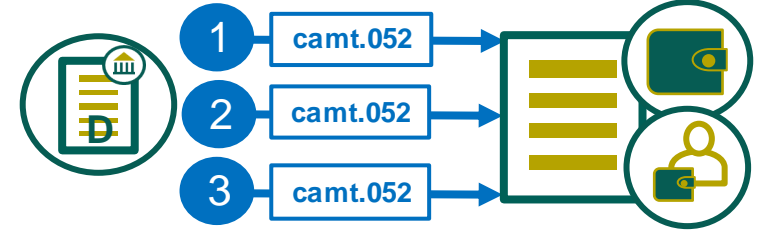

1 Report Pagination
Page 1
Last Page No

¹₄³₅ Electronic Sequence Number 16
Legal Sequence Number 3

Account
Id 12345
Currency EUR

Entry
.....

2 Report Pagination
Page 2
Last Page No

¹₄³₅ Electronic Sequence Number 16
Legal Sequence Number 3

Account
Id 12345
Currency EUR

Entry
.....

3 Report Pagination
Page 3
Last Page Yes

¹₄³₅ Electronic Sequence Number 16
Legal Sequence Number 3

Account
Id 12345
Currency EUR

Balance
ITAV Interim Available

Entry
.....

Report Order: identifying the order in which statements should be processed or reconstituted. Options:

Report Pagination

Report Correlation: identifying statement which relate to each other for a given statement period. Options:

Legal Sequence Number
¹₄³₅ Electronic Sequence Number
 Account (Identifier and Currency)

Last Report: identifying when no further statements for a given period are expected i.e. period statement in finalised. Options:

Report Pagination, Last Page Indicator
 Balance Type ITAV (where balance information is also reported)



When reporting the *Balance* together with Transaction entries, it is recommended to include the balance detail/s on the last report. Of course, where reporting only balance/s i.e. only a balance report (no entries) the data content will be contain in a single message.

camt.052 Bank to Customer Account Report - Identification

Min 1 – Max 1

The Bank to Customer Account Report message **Identification** provides a mandatory element to identify the statement



Unique reference assigned by the account servicer to unambiguously identify the account report. Directly comparable with the *Transaction Reference Number* (Field 20) of the legacy MT statement message.

Report  Identifier

camt.052 Bank to Customer Account Report – Report Pagination

The Bank to Customer Account Report message **Report Pagination** ^{Min 1 – Max 1} element provides the page number of the report.



Report Pagination ^{Min 1 – Max 1} includes the **Page Number** ^{Min 1 – Max 1} and **Last Page indicator** ^{Min 1 – Max 1} elements.

For example, a *Page Number* of 2 represents the current account report, being the second page of the and implying a previous account report page had been sent. The *Last Page indicator* further implies whether more pages are expected



Noted: as **Report Pagination** is required, even if there is only one page to the report being sent. Both the **Page Number** and **Last Page indicator** will need to be provided i.e., 1 and Yes.

Report > Report Pagination ✓

Page Number

Last Page indicator



camt.052 Bank to Customer Account Report - Electronic Sequence Number

Min 0 – Max 1

The Bank to Customer Account Report message **Electronic Sequence Number** allows the *Account Servicer* to assign a number to each Report which should increment by 1 for each electronic statement report sent.



This element allows easy recognition of the Report order, equivalent to the legacy Field 28C Statement Number. The sequence should increment for each camt.052 message sent to the Account Owner or Authorised Party this number must be the same value where the statement continues over multiple pages (*Report Pagination*) of the report for a give account.

Should this sequence number be reset by the *Account Servicer*, this should not occur more frequently than once a day. Likewise, this 18 digit counter could be incremented to its maximum value before it's reset.



The use of Electronic Sequence Number and the sequence reset logic should be bilaterally agreed between the *Account Servicer* and the *Account Owner*. Either **Electronic Sequence Number** or **Legal Sequence Number** Should be provided to enable the identification of a statement number.

Report  Electronic Sequence Number

camt.052 Bank to Customer Account Report - Reporting Sequence

The Bank to Customer Account Report message **Reporting Sequence** ^{Min 0 – Max 1} specifies the choice of identification sequences. This can be used as an alternative to the **Report Pagination** or **Electronic Sequence Number** as a way to identify the report order, which is not confined to numeric values.

Where used the **Reporting Sequence** mandate a choice of nested element:

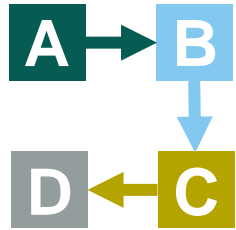

- **From Sequence** identifies the start of a sequence range. ^{Min 1 – Max 1}
- **To Sequence** identifies the end of a sequence range. ^{Min 1 – Max 1}
- **From To Sequence** identifies the start and end of a sequence range. ^{Min 1 – Max *}
- **Equal Sequence** identifies a sequence. ^{Min 1 – Max *}
- **Not Equal Sequence** identifies a sequence to be excluded. ^{Min 1 – Max *}

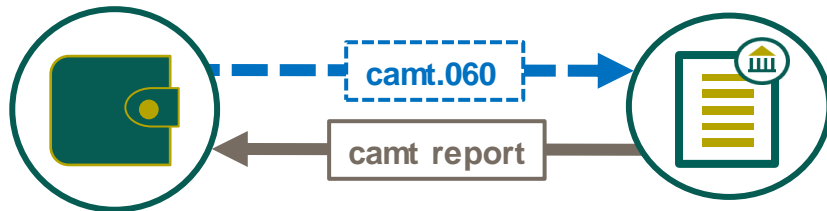

The Reporting Sequence may be provided in the camt.060 Account Reporting request to specify, for example, a range of Statements to be sent. Alternatively, Account Reports can often be produced on a bilaterally agreed period basis.

Report Report Sequence

camt.052 Bank to Customer Account Report - Legal Sequence Number

Min 0 – Max 1

The Bank to Customer Account Report message **Legal Sequence Number** allows the *Account Servicer* to assign a number to each report which should increment by 1 for each Report sent.



Where the Intraday Account Report uses multiple camt.052 messages for a given report period the **Legal Sequence Number** must be the same number in each report message during that reporting period. This element can be considered an equivalent to the legacy Field 28C Statement Number



Either **Electronic Sequence Number** or **Legal Sequence Number** should be provided to enable the identification of a report number.

Report  Legal Sequence Number

camt.052 Bank to Customer Account Report - Creation Date Time

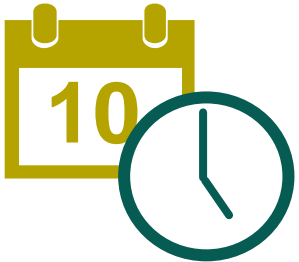

CBPR+ usage guidelines mandate the time zone that the time represents as an offset against Universal Time Coordinated (UTC):

Local time with UTC offset `YYYY-MM-DDThh:mm:ss.sss+/-hh:mm`

- For example: `2002-10-10T12:00:00-05:00` (noon/midday on 10 October 2002, Central Daylight Savings Time as well as Eastern Standard Time in the U.S.)



All CBPR+ time elements need offset against UTC. Milliseconds are optional.

camt.052 Bank to Customer Account Report – From To Date

Min 0 – Max 1

The Bank to Customer Account Report message **From to Date** allows the *Account Servicer* to specify the start date time and end date time applicable to the intraday account entries and or accounting balances being reported.

For intraday account reports this is an important attribute that allows the account owner to understand the period for which the report applies. The element is not mandatory as the report may only contain the balance, whereby the report **Creation DateTime** may be used to identify the date and time associated to the balance.

Min 1 – Max 1

Min 1 – Max 1

Where **From to Date** is used the **From Date Time** and **To Date Time** become mandatory elements.

CBPR+ usage guidelines mandate the time zone that the time represents as an offset against Universal Time Coordinated (UTC):

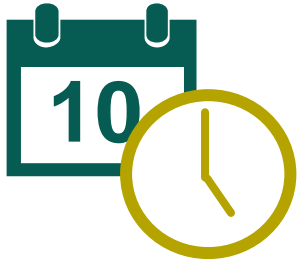

Local time with UTC offset YYYY-MM-DDThh:mm:ss.sss+/-hh:mm

- For example: 2002-10-10T12:00:00-05:00 (noon/midday on 10 October 2002, Central Daylight Savings Time as well as Eastern Standard Time in the U.S.)



All CBPR+ time elements need offset against UTC. Milliseconds are optional.

Report 

From to Date

To Date Time



camt.052 Bank to Customer Account Report – Copy Duplicate Indicator

Min 0 – Max 1

The Bank to Customer Account Report message **Copy Duplicate Indicator** is used as a choice to identify additional reports from the original sent to the Account Owner.

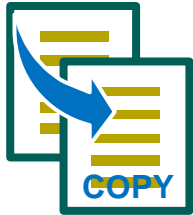

COPY is used when a copy of the report is sent to an Authorised Third Party, such as a company head office, parent entity, or an institution providing additional service.

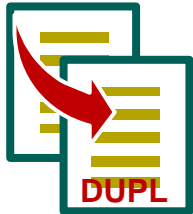

DUPL is used when a duplicate of the report is sent to the Account Owner, this resubmission may have been requested using the camt.060 or an alternative channel such as via internet banking or customer service request.

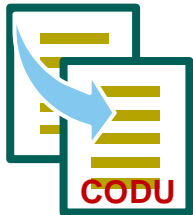

CODU is used when a duplicate of a report copy is sent to an Authorised Third Party, this resubmission may have been requested using the camt.060 or an alternative channel such as via internet banking or customer service request. It may also be requested by the Account Owner on behalf of the Authorised Third Party, depending on the arrangement in place with the Account Servicer.

Report  Copy Duplicate Indicator 

camt.052 Bank to Customer Account Report – Reporting Source

Min 0 – Max 1

The Bank to Customer Account Report message **Reporting Source** allows the *Account Servicer* to define the source of the intraday account entry and or account balance report, typically associated with an application.

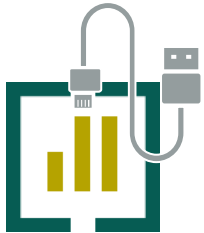

Reporting Source utilises the external Reporting Source code list. For example **ACCT** represents a statement or report based on accounting data, whereas **DEPT** represents a cash or deposit system.

Where the source of the statement is functionally required by the consumer of the statement i.e., the *Account Owner* or *authorised Third Party*, the codes used should be bilaterally agreed.

Report > Reporting Source <

camt.052 Bank to Customer Account Report - Account

The Bank to Customer Account Report message **Account** provides nested elements to identify the account for which debit and credit entries have been made. The following two mandatory elements are nested beneath *Account*.

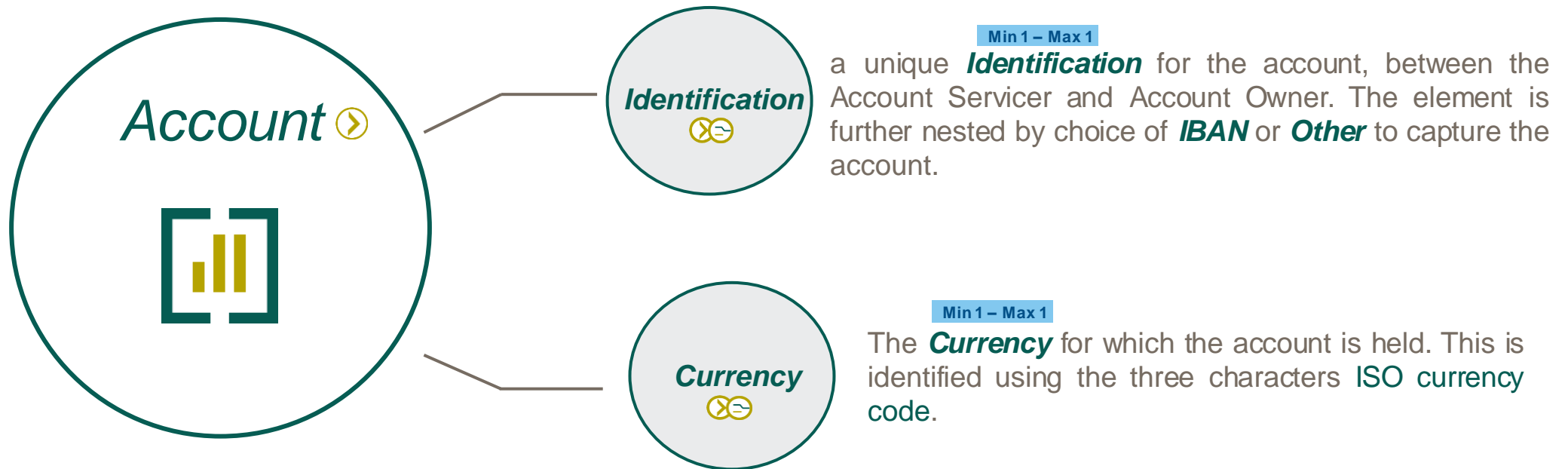

Report > Account >

camt.052 Bank to Customer Account Report - Account (continued)

Min 1 – Max 1

Min 0 – Max 1

The Bank to Customer Account Report message mandatory **Account** also provides a number of optional nested element to identify the account for which debit and credit entries have been made.

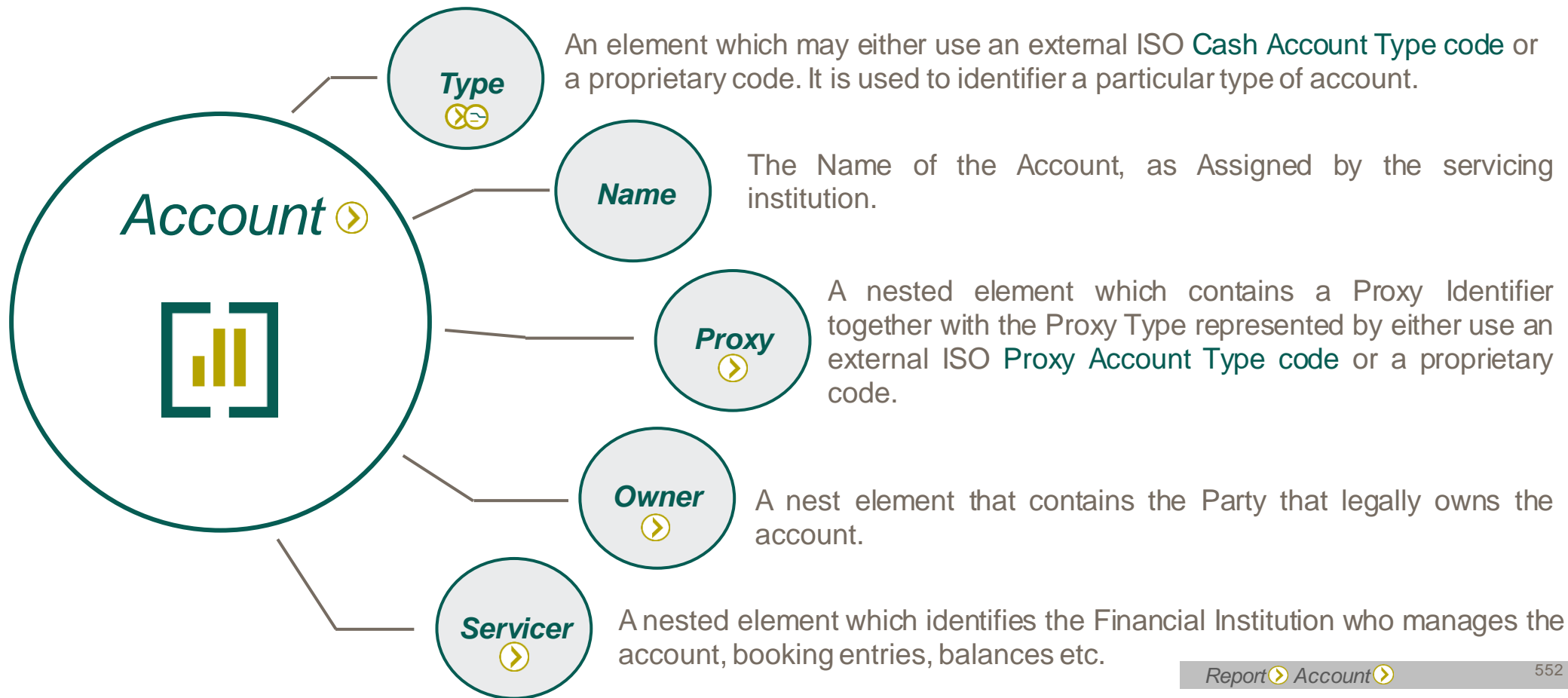

camt.052 Bank to Customer Account Report – Related Account

Min 0 – Max 1

The Bank to Customer Account Report message **Related Account** allows the identification of a related parent account for the account report. For example sweeping, pooling or virtual account for which the report is produced can identify the parent account they hierarchically relate to.



When **Related Account** is utilized, like **Account**, the **Identification** and **Currency** element become mandatory.

Min 1 – Max 1

Min 1 – Max 1

Additionally, the nested **Type** element, **Name** and nested **Proxy** element are optionally available.

Min 0 – Max 1

Min 0 – Max 1

Min 0 – Max 1



Related Account uses a variety of common elements described in more detail within the **Account** section.

Report > Related Account

Identification

Type

Currency

Name

553

Proxy

camt.052 Bank to Customer Account Report – Interest

Min 0 – Max *

The Bank to Customer Account Report message **Interest** provides interest information that applies to the account.

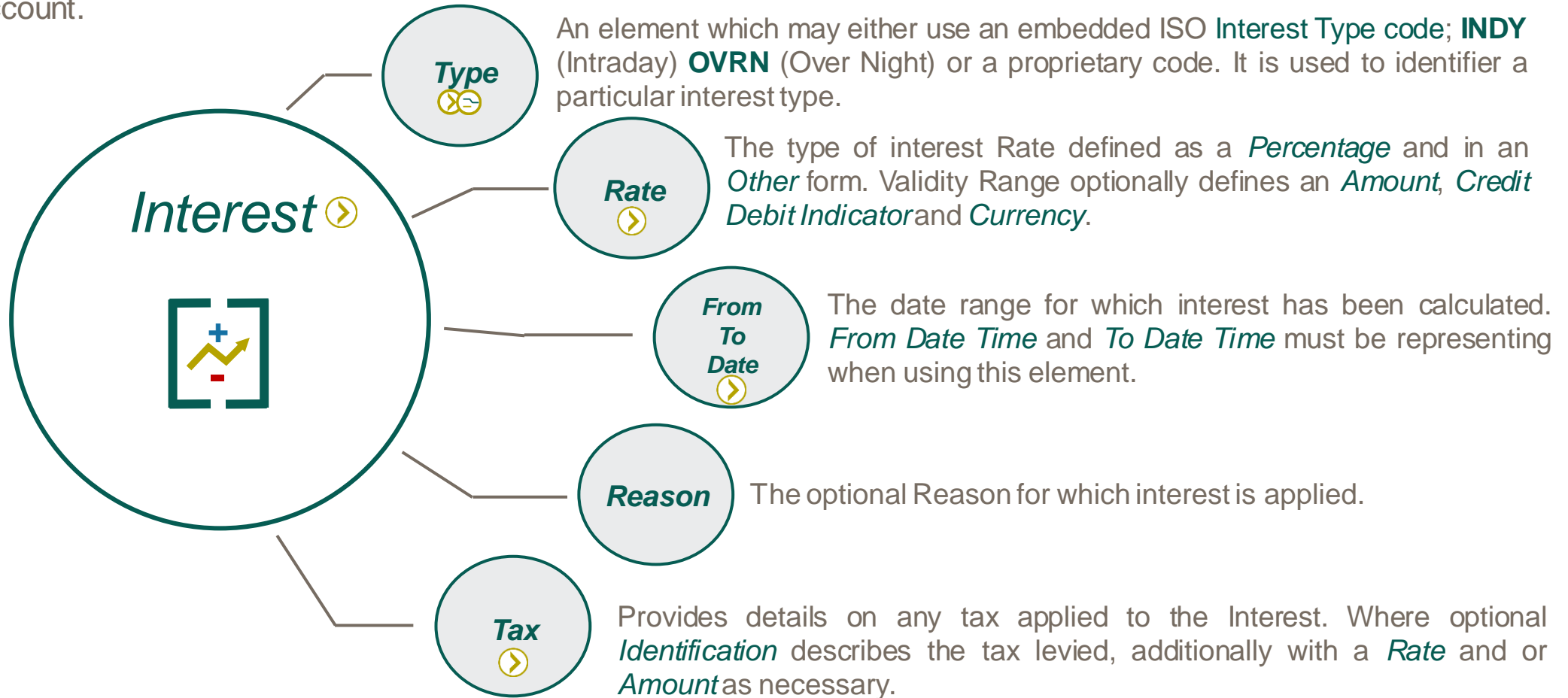

camt.052 Bank to Customer Account Report - Balance

The Bank to Customer Account Report message optional **Balance** is a nested element to define the account balance at a specific point in time. The following four elements nested beneath **Balance** are mandatory

Min 0 – Max *

Min 1 – Max 1

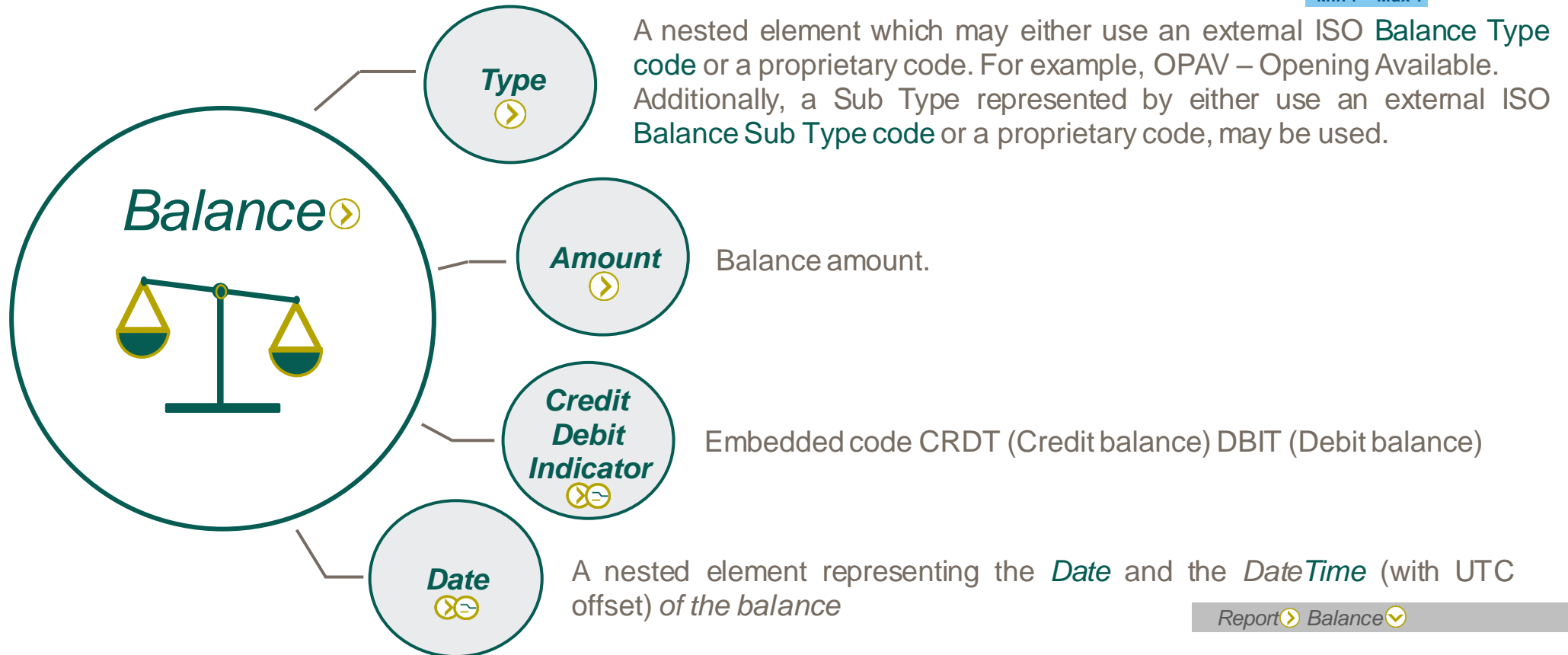

Report > Balance >



The Balance element is unlimited (Max *) whereby more than one Type of balance may be reported

camt.052 Bank to Customer Account Report – Balance Type code

Balance Type code are used within the nested *Balance* element to represent the type/s of balance being reported. In comparison the legacy MT 941 utilizes different Fields and Tag options to represent a number of these Balance Types. The below extract from the externalised ISO *Balance Type* code list compares the code with the population of the equivalent information in the Legacy MT 941 Balance Report.

Code	Name	Definition	MT 941 Comparison
CLAV	ClosingAvailable	Closing balance of amount of money that is at the disposal of the account owner on the date specified.	Field 64
CLBD	ClosingBooked	Balance of the account at the end of the pre-agreed account reporting period. It is the sum of the opening booked balance at the beginning of the period and all entries booked to the account during the pre-agreed account reporting period.	Field 62F
FWAV	ForwardAvailable	Forward available balance of money that is at the disposal of the account owner on the date specified.	Field 65
INFO	Information	Balance for informational purposes.	No equivalent
ITAV	InterimAvailable	Available balance calculated in the course of the account servicer's business day, at the time specified, and subject to further changes during the business day. The interim balance is calculated on the basis of booked credit and debit items during the calculation time/period specified.	Field 64
ITBD	InterimBooked	Balance calculated in the course of the account servicer's business day, at the time specified, and subject to further changes during the business day. The interim balance is calculated on the basis of booked credit and debit items during the calculation time/period specified.	Field 62F
OPAV	OpeningAvailable	Opening balance of amount of money that is at the disposal of the account owner on the date specified.	No equivalent
OPBD	OpeningBooked	Book balance of the account at the beginning of the account reporting period. It always equals the closing book balance from the previous report.	Field 60F
PRCD	PreviouslyClosedBooked	Balance of the account at the previously closed account reporting period. The opening booked balance for the new period has to be equal to this balance. Usage: the previously booked closing balance should equal (inclusive date) the booked closing balance of the date it references and equal the actual booked opening balance of the current date.	No equivalent
XPCD	Expected	Balance, composed of booked entries and pending items known at the time of calculation, which projects the end of day balance if everything is booked on the account and no other entry is posted.	No equivalent



[Take me to an implementation example involving *Balance Type* codes](#)

camt.052 Bank to Customer Account Report – Balance (continued)

Min 1 – Max *

The Bank to Customer Account Report message mandatory **Balance** also provides the optional set of nested element to define a **Credit Line**

Min 0 – Max *

The true/false Boolean of **Included** to clearly determine whether the Credit Line Amount is included in the balance is mandatory in the set of Credit Line element.

Additionally, the following optional nested element may be used to identify:

- The **Type** of Credit Line, which may either use an external ISO Credit Line Type code or a proprietary code.
- A set of elements to provide **Credit Line** details
- The **Amount** (Currency and Amount) of the Credit Line
- The **Date** (nested as Date, DateTime) of the Credit Line, provided to distinguish where multiple Credit Line exist.



The final optional nested element within **Balance** is the **Availability** of the booked amount i.e., when it is available to be accessed.



The **Credit Line** element is unlimited (Max *) whereby more than one **Credit Line** may be reported, the **Date** becomes an important element to distinguish between different Credit Lines.

Report	Balance
Type	
Credit Line	
Amount	
Credit Debit Indicator	
Date	
Availability	

camt.052 Bank to Customer Account Report – Transaction Summary

Min 0 – Max 1

The Bank to Customer Account Report message optional **Transaction Summary** provides a set of nested element to summarize entry information. Where the intraday account entries and or accounting balances are reported using multiple camt.052 messages for a given reporting period the *Transaction Summary* should only be included on the first Report message (*Balance Type* OPBD with no *Balance Sub Type*) summarizing the whole Statement Report (entire statement period) This aligns with the Common Global Implementation (CGI) where a *Transaction Summary*, if provided, would appear before the first *Entry* elements.



Each of the following element allow an optional total of entries either as a **Number of Entries** and or as a **Sum**.

- **Total Entries**
- **Total Credit Entries**
- **Total Debit Entries**
- **Total Entries Per Bank Transaction Code**

Min 0 – Max *

In addition to the **Number of Entries** and **Sum**, the **Total Entries Per Bank Transaction Code** requires the **Bank Transaction Code** element and optionally allows a variety of other optional elements.

Min 1 – Max 1



The **Total Entries Per Bank Transaction Code** element is unlimited (Max *) whereby more that one *Bank Transaction Code* may be summarised.

Report ▶ Transaction Summary ▼

Total Entries ▶

Total Credit Entries ▶

Total Debit Entries ▶

Total Entries per Bank Transaction Code ▶

camt.052 Bank to Customer Account Report – Entry

The Bank to Customer Account Report message optional **Entry** provides a significant variety of nested elements to represent the details associated with each **Entry**. For active accounts which have intraday entries posted across them, this set of nested elements is arguably the most relevant for the account owner and in many way is comparable with the MT 942 Field 61 Statement Line.

Unlike the legacy MT Interim Transaction Report message, the camt.052 has a number of dedicated elements to capture a variety of entry level data. It also has a number of enhancements on the legacy MT Interim Transaction Report message where parties in the payment and customer remittance information, as examples, can be provided to the *Account Owner*.

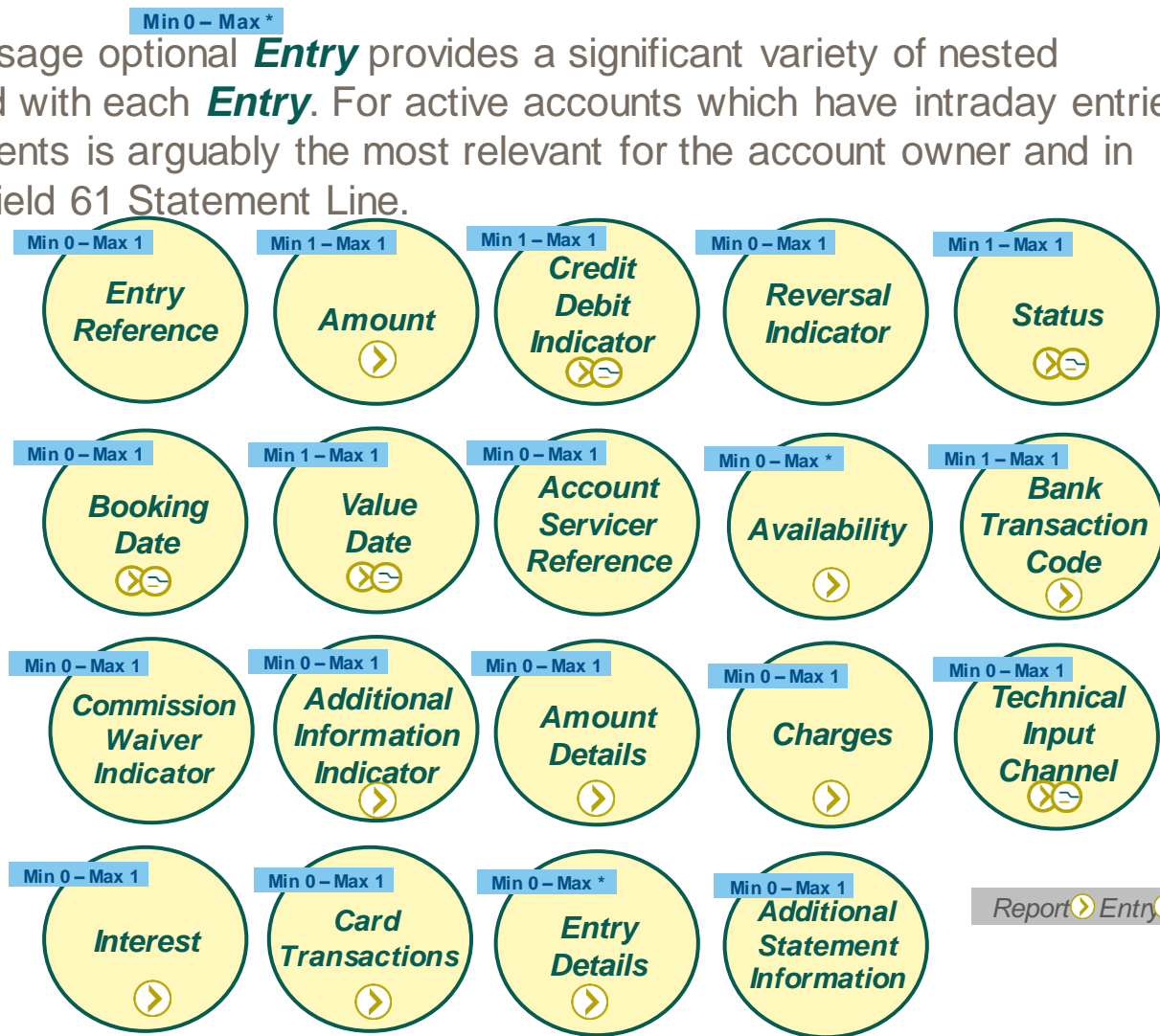

Report ➤ Entry ➤

camt.052 Bank to Customer Account Report – Entry (continued)

Min 0 – Max 1

Entry Reference

Unique reference for the booking entry, created by the Account Servicing Institution as a reference they assign to identify the entry posted to the account.

Min 1 – Max 1

Amount

Mandatory element representing the currency and amount of the entry. This can be compared to Field 61 subfield 4 and 5 of the legacy MT 942.

Min 1 – Max 1

Credit Debit Indicator

Mandatory element indicating whether the **Amount** entry is a **DBIT** (Debit) or **CRDT** (Credit) to the account. This can be compared to Field 61 subfield 3 of the legacy MT 942.

Min 0 – Max 1

Reversal Indicator

Indicates whether the entry is a result of a reversal. For example, an entry related to a pacs.004 Payment Return or reverses an error such as an incorrect value date applied to the entry. Where the **Reversal Indicator** is **Yes**, the **Credit Debit Indicator** should be the opposite of the original entry, for example original **Credit Debit Indicator** of **CRDT** would expect a reversal entry **Credit Debit Indicator** of **DBIT**. This can be compared to Field 61 subfield 3 of the legacy MT 942 where a reversal code may be used.



camt.052 Bank to Customer Account Report – Entry (continued)

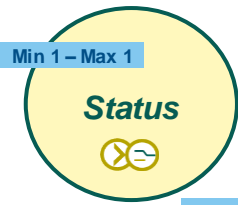

Mandatory element representing the status using an external ISO **Entry Status** code for example BOOK is used to confirm the entry is booked.



Status BOOK is the only status that can be reversed using the **Reverse Indicator**

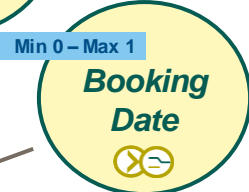

Mandatory choice of **Date** or **Date Time** the entry was posted to the **Account**. This can be compared to Field 61 subfield 2 of the legacy MT 942.

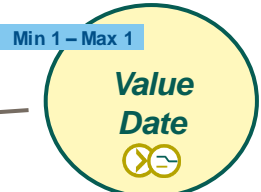

Mandatory choice of **Date** or **Date Time** the entry become available. This can be compared to Field 61 subfield 1 of the legacy MT 942.



Noting CBPR+ usage guidelines mandate the time zone that the **Date Time** represents as an offset against Universal Time Coordinated (UTC)

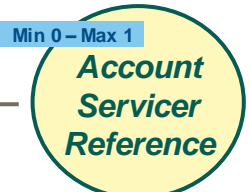

Additional optional Reference typically assigned by the Account Servicer's payment engine or accounting platform. This reference would be used to query an entry. This can be compared to Field 61 subfield 8 of the legacy MT 942.

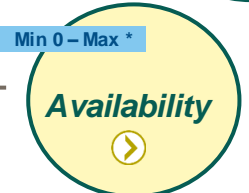

Indicates when the booked amount is available i.e., when it is available to be accessed.



camt.052 Bank to Customer Account Report – Entry (continued)

Min 1 – Max 1

Bank Transaction Code



The **Bank Transaction Code** is designed to deliver a harmonized set of codes, which should be applied in bank-to-customer cash account reporting information. The bank transaction code information allows the **account servicer** to correctly report a transaction, which in its turn will help **account owners** to perform their cash management and reconciliation operations.

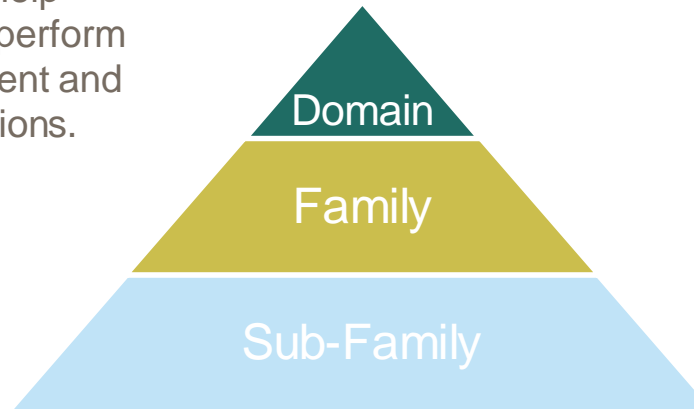

The structure of the Bank Transaction Code has three levels:

Domain: Highest definition level to identify the sub-ledger. The domain defines the business area of the underlying transaction e.g., payment, securities etc.)

Family: Medium definition level e.g. type of payment; credit transfer, direct debit etc.

Sub-family: Lowest definition level e.g. type of cheques; draft etc.

Bank Transaction Codes are an external code set defined in the *Bank Transaction Code combinations* external code sets.

Report > Entry > Bank Transaction Code

Domain

Family 562

Sub Family



camt.052 Bank to Customer Account Report – Bank Transaction Code descriptions

Min 1 – Max 1

Payments Domain Families		
1. Received Credit Transfers	Receivable Credit Transfers are instructions to receive an amount of money from a del the account owner. The receivable credit transfers are related to transactions received t account owner.	
2. Issued Credit Transfers	Payable Credit Transfers are instructions to transfer an amount of money by the accou to a creditor. The payable credit transfers are related to instructions sent by the accoun	
3. Received Cash Concentration	Transaction is related to incoming cash movements that are related to cash managemen activities initiated by the owner of the sending account to optimise the return on the av funds.	
4. Issued Cash Concentration	Transaction is related to outgoing cash movements that are related to cash managemen activities initiated by the owner of the account to optimise the return on the available f	
5. Received Direct Debits	The Received Direct Debit transactions are related to instructions received by the acco to debit the account.	
6. Issued Direct Debits	The Issued Direct Debit transactions are related to instructions sent by the account owi collect an amount o	
7. Received Cheques	Transaction is relat from the cheque dr:	
8. Issued Cheques	Transaction is relat	
Sub-Families for both Received and Issued Credit Transfers		
	Sub-Family	Definition
	Internal Book Transfer	Transaction is a transfer between –two different accounts within the same bank.
	Standing Order	Transaction is a standing order. A standing order is an instruction given by a party having authority on the debtor’s account to debit, i.e. either debit account owner or originating p; account servicer, to process credit transfers at specified intervals during an implicit or exp period of time. It is given once, and is valid for an open or closed period of time.
	Cross-Border Standing Order	Transaction is a cross-border standing order
	SEPA Credit Transfer	Transaction is a SEPA credit transfer
	Domestic Credit Transfer	Transaction is a in-country domestic currency credit transfer
	Cross-Border Credit Transfer	Transaction is a cross-border credit transfer
	Credit Transfer with agreed Commercial Information	Transaction is a credit transfer including commercial information, i.e. additional informat agreed between the sender and the receiver.
	Financial Institution Credit Transfer	Transaction is a financial institution credit transfer, i.e. the debtor and creditor are financi institutions.
	Priority Credit Transfer	Transaction is a credit transfer defined with higher priority, eg a PRIEURO credit transfe:
	Payroll/Salary Payment	Transaction is related to the payment of a payroll salary
	Cross-border	Transaction is related to the payment of a cross-border payroll salary

The description of **Bank Transaction Codes** are available to download from the ISO20022.org external code list page. These include the descriptions for Payments Domain Families and sub-families for both Received and Issued Credit Transfers.

https://www.iso20022.org/external_code_list.page



camt.052 Bank to Customer Account Report – Bank Transaction Code combinations

Bank Transaction Code - all permitted combinations of the BTC code sets							
All codes in light grey are defined as the generic codes available for all Domains and Families							
Domain	Family	SubFamily	Domain Code	Family Code	SubFamily Code	Status	Status Date
Payments	Issued Credit Transfers	Cross-Border Credit Transfer	PMNT	ICDT	XBCT	New	27/4/2009
Payments	Received Credit Transfers	Cross-Border Credit Transfer	PMNT	RCDT	XBCT	New	27/4/2009

Bank Transaction Codes are an external code set defined in the *Bank Transaction Code combinations* external code sets.

As an example a debit statement transaction which relates to a cross-border payment initiated from an account would be represented by:

Domain	Family	Sub-Family
PMNT (Payment)	ICDT (Issued Credit Transfer)	XBCT (Cross-Border Credit Transfer)



camt.052 Bank to Customer Account Report – Entry (continued)

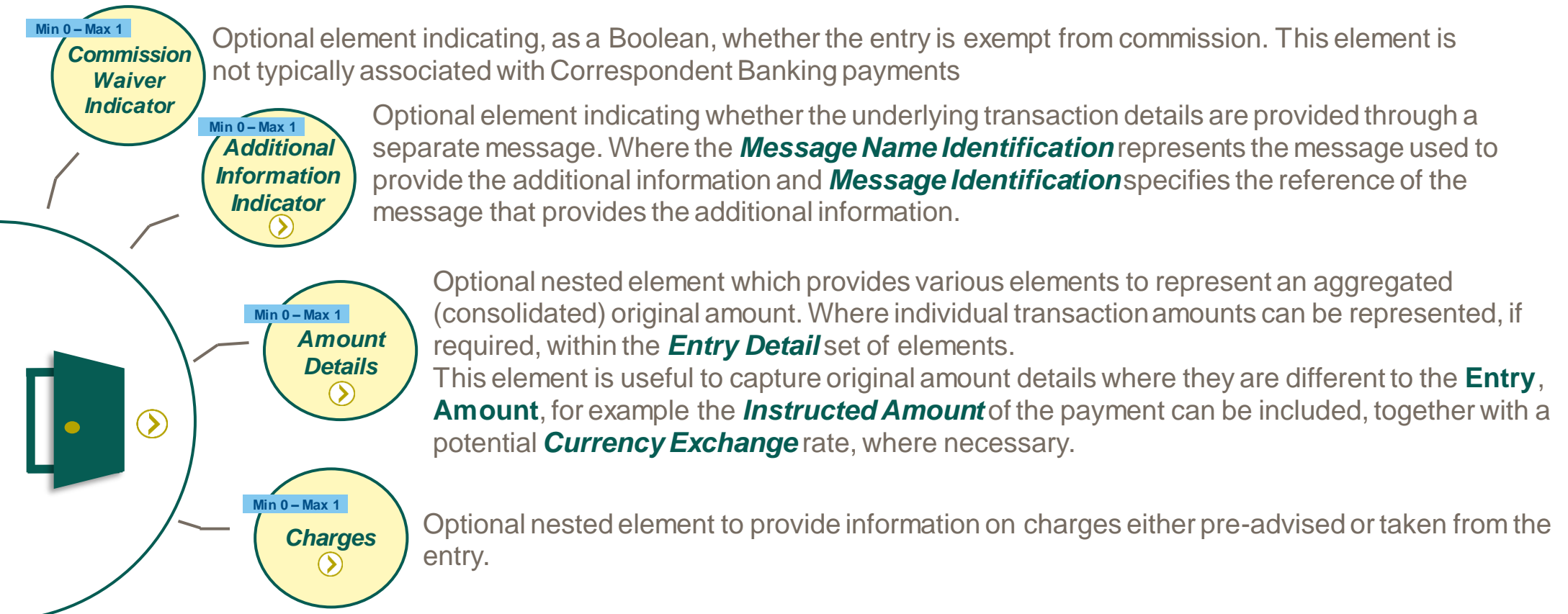

camt.052 Bank to Customer Account Report – Entry (continued)

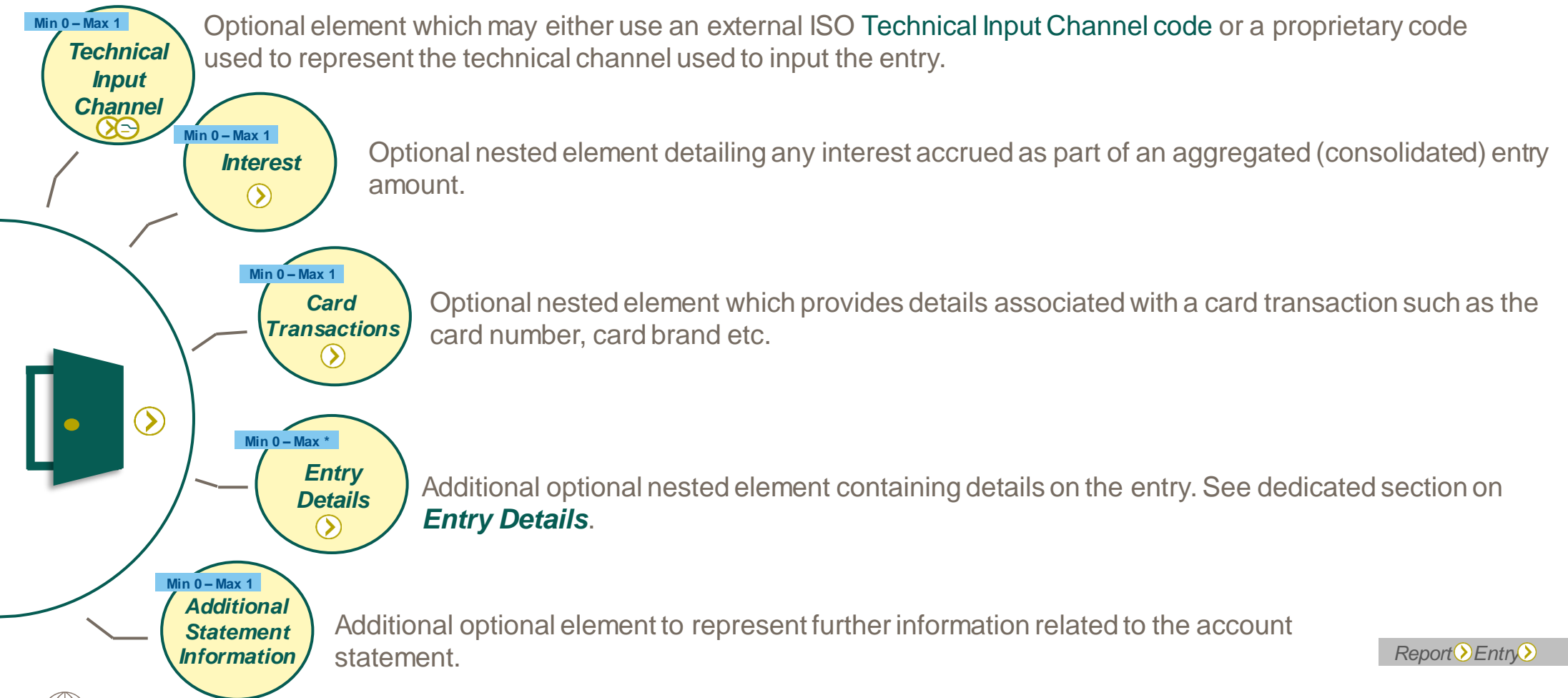

camt.052 Bank to Customer Account Report – Entry Details

The Bank to Customer Account Report message optional **Entry Details** provides a variety of nested elements to represent the details associated with each **Entry**.

Min 0 – Max *



Batch provides details on batched transactions such as the total **Number of Transactions** the batched entry (sometimes referred to as a consolidated entry) represents.

Transaction Details is a significant nested element which represents information on the underlying transaction.



Report ▶ Entry ▶ Entry Details ▼

Batch ▶

Transaction Details ▶

camt.052 Bank to Customer Account Report – Transaction Details

When the Bank to Customer Account Report message optional **Entry Details** is utilized the nested **Transaction Details** element is mandatory.

Transaction Details has a variety of nested elements closely associated with **Entry** level elements. The **References** element however is nested to include a variety of references related to the entry including for example the **UETR**

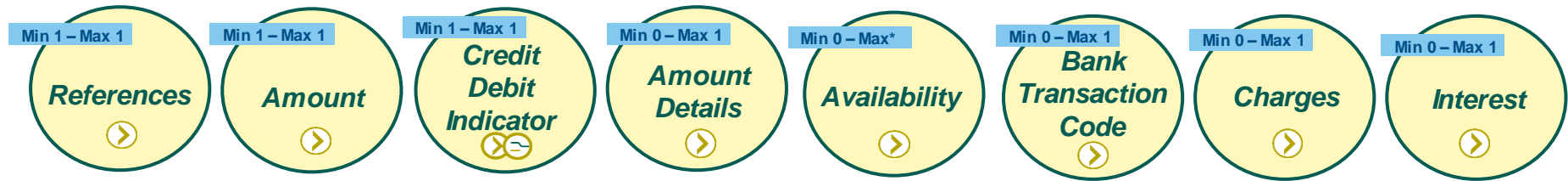

Additionally, **Transaction Details** also has a variety of elements capturing details from the underlying transaction, which amongst other business transactions includes payment transaction data. For example, **Remittance Information** and **Related Parties**

Report > Entry > Entry Details > Transaction Details >

camt.052 Bank to Customer Account Report – Related Parties & Related Agents

Min 0 – Max 1

Min 0 – Max 1

The Bank to Customer Account Report message **Related Parties** and **Related Agents** represents a set of optional nested elements related to the underlying transaction. Where the **Entry Details** (the set of elements **Related Parties/Agents** belongs to) relate to a Payment, Clearing and Settlement (pacs) message, parties in the pacs messages can be transferred into the Cash Management (camt) message.



These **Related Parties** include :

- *Instructing Party*
- *Debtor*
- *Debtor Account*
- *Ultimate Debtor*
- *Creditor*
- *Creditor Account*
- *Ultimate Creditor*

These **Related Agents** include :

- *Instructing Agent*
- *Instructed Agent*
- *Debtor Agent*
- *Creditor Agent*
- *Intermediary Agent 1*
- *Intermediary Agent 2*
- *Intermediary Agent 3*



Trading Party is also present in the **Related Parties** elements, and the following are present in the **Related Agents** elements: **Receiving Agents, Delivering Agent, Issuing Agent and Settlement Place**. Although these elements are not directly associated with a payment, as a Customer receiving an Account Report related to other Business Domains e.g. a Security Settlement, it could be conceivable that these optional CBPR+ element may be populated



Report ▶ Entry ▶ Entry Details ▶ Transaction Details ▼

Related Parties ▼

Related Agents ▶

camt.052 Bank to Customer Account Report – other underlying data

The Bank to Customer Account Report message **Entry Details** have a number of additional elements beyond **Related Parties** and **Related Agents** to capture information from the underlying payment.

These are:

- *Local Instrument*
- *Purpose*
- *Related Remittance Information*
- *Remittance Information*
- *Related Dates* such as the *Interbank Settlement Date*
- *Tax*

For *Payment Return* (pacs.004) it is also possible to capture **Return Information** which includes:

- The *Original Bank Transaction Code* of the original Entry
- The *Originator* of the return from the pacs.004
- And the *Reason* code.

Remittance Information as an end-to-end element should be passed unaltered from Payment Initiation (pain) into the Payment, Clearing and Settlement (pacs) message and onto the Bank to Customer Account Statement/Account Report (camt) The *Remittance Information* element is common to these message sets.



camt.052 Bank to Customer Account Report – other underlying data (continued)

It should also be mentioned that the Bank to Customer Account Report message **Entry Details** have a number of additional elements which capture information from transactions in other business domains beyond payments, as well as have an element to capture **Additional Transaction Information**.



These are:

- *Related Quantity*
- *Financial Instrument Identification*
- *Corporate Action*
- *Safekeeping Account*
- *Cash Deposit*
- *Card Transactions*

Index of camt.052 Use Cases

Use case should be considered as a principal example whereby use case may be cross referenced

Bank to Customer Reports

Use Case c.52.1.a – Bank to Customer Account Balance Report produced by the Creditor Agent

Use Case c.52.1.b – Bank to Customer Account Intraday Transaction Report produced by the Creditor Agent

Use Case c.52.1.b.1 – Bank to Customer Account Intraday Transaction Report/s and Account Statement produced by the Creditor Agent

Use Case c.52.1.c – Bank to Customer Account Intraday Transaction and Balance Report produced by the Creditor Agent



Use Case camt.060 for requesting a Bank to Customer report



Use Case for copy or duplicate reports refer to camt.053 use cases

Bank to Customer Account Balance Report produced by the Creditor Agent

Use Case c.52.1.a

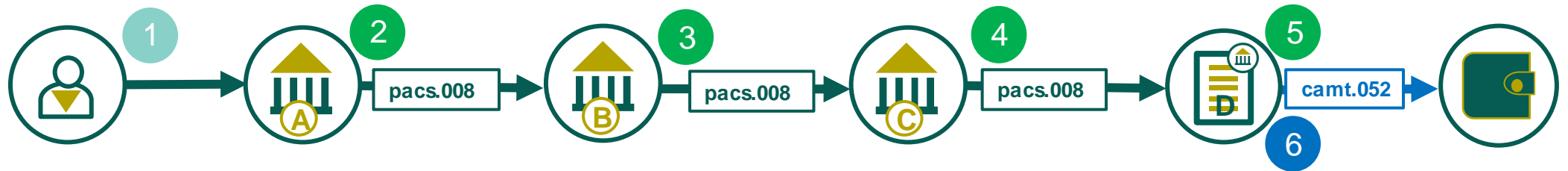

1

Debtor initiates a payment instruction to the Debtor Agent

2

Debtor Agent (A) initiates a serial payment towards the Creditor Agent (D) using Agents B & C as intermediaries

3

Agent B processes the payment on Agent C

4

Agent C processes the payment on Agent D

5

Creditor Agent credits the account of the Creditor

6

Creditor Agent as the Account Servicer produces and sends a balance report to either the Account Owner, or an authorised third party.

Bank to Customer Account Intraday Transaction Report produced by the Creditor Agent

Use Case c.52.1.b

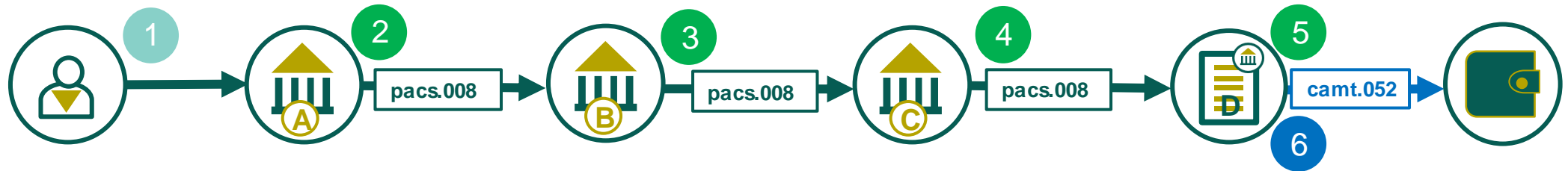

1 Debtor initiates a payment instruction to the Debtor Agent

2 Debtor Agent (A) initiates a serial payment towards the Creditor Agent (D) using Agents B & C as intermediaries

3 Agent B processes the payment on Agent C

4 Agent C processes the payment on Agent D

5 Creditor Agent credits the account of the Creditor

6 Creditor Agent as the Account Servicer produces and sends a balance report to either the Account Owner, or an authorised third party.

Bank to Customer Account Intraday Transaction/s Report/s and Account Statement produced by the Creditor Agent

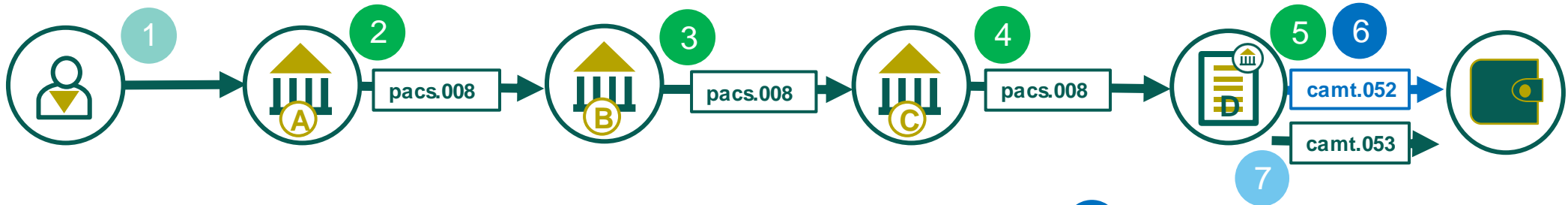

1 Debtor initiates a payment instruction to the Debtor Agent

2 Debtor Agent (A) initiates a serial payment towards the Creditor Agent (D) using Agents B & C as intermediaries

3 Agent B processes the payment on Agent C

4 Agent C processes the payment on Agent D

5 Creditor Agent credits the account of the Creditor

6 Creditor Agent as the Account Servicer produces and sends several intraday transaction reports throughout the business day to either the Account Owner, or an authorised third party.

7 Creditor Agent C as the Account Servicer produces an Account Statement at the close of the business day reflecting all the transaction entries, include those provide in the Intraday Transaction Report



Bank to Customer Account Intraday Transaction and Balance Report produced by the Creditor Agent

Use Case c.52.1.c

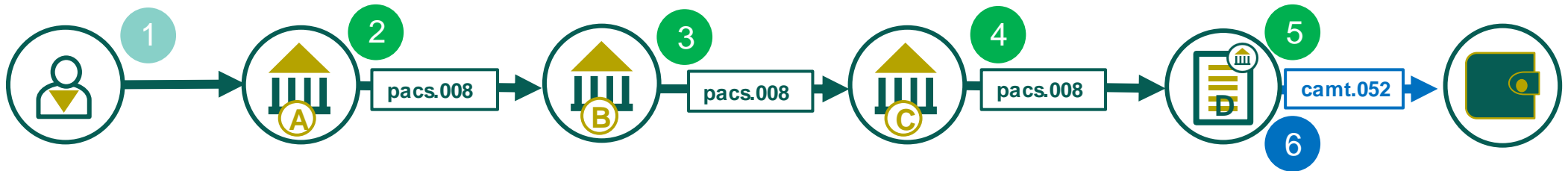

1 Debtor initiates a payment instruction to the Debtor Agent

2 Debtor Agent (A) initiates a serial payment towards the Creditor Agent (D) using Agents B & C as intermediaries

3 Agent B processes the payment on Agent C

4 Agent C processes the payment on Agent D

5 Creditor Agent credits the account of the Creditor

6 Creditor Agent as the Account Servicer produces and sends an intraday transaction and balance report to either the Account Owner, or an authorised third party.

camt.053

Bank to Customer Statement



camt.053 Bank to Customer Account Statement

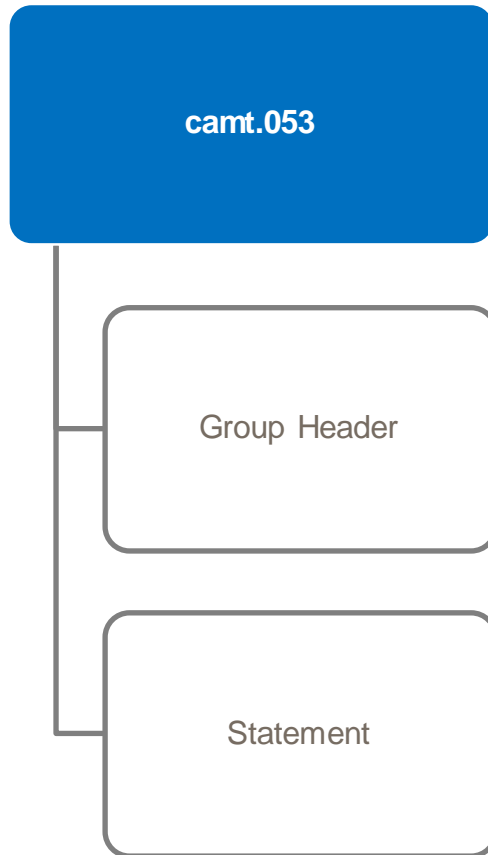

The *Bank To Customer Statement* message is sent by the account servicer to an account owner or to a party authorised by the account owner to receive the message. It is used to inform the account owner, or authorised party, of the entries booked to the account, and to provide the owner with balance information on the account at a given point in time



The Bank to Customer Account Statement is restricted to a single account statements per InterAct message (100,000 bytes)
This message must be bilaterally agreed between the Account Servicing Institution and the Account owner, and is establish by an RMA business profile.

High Level Bank to Customer Statement (camt.053)

camt.053

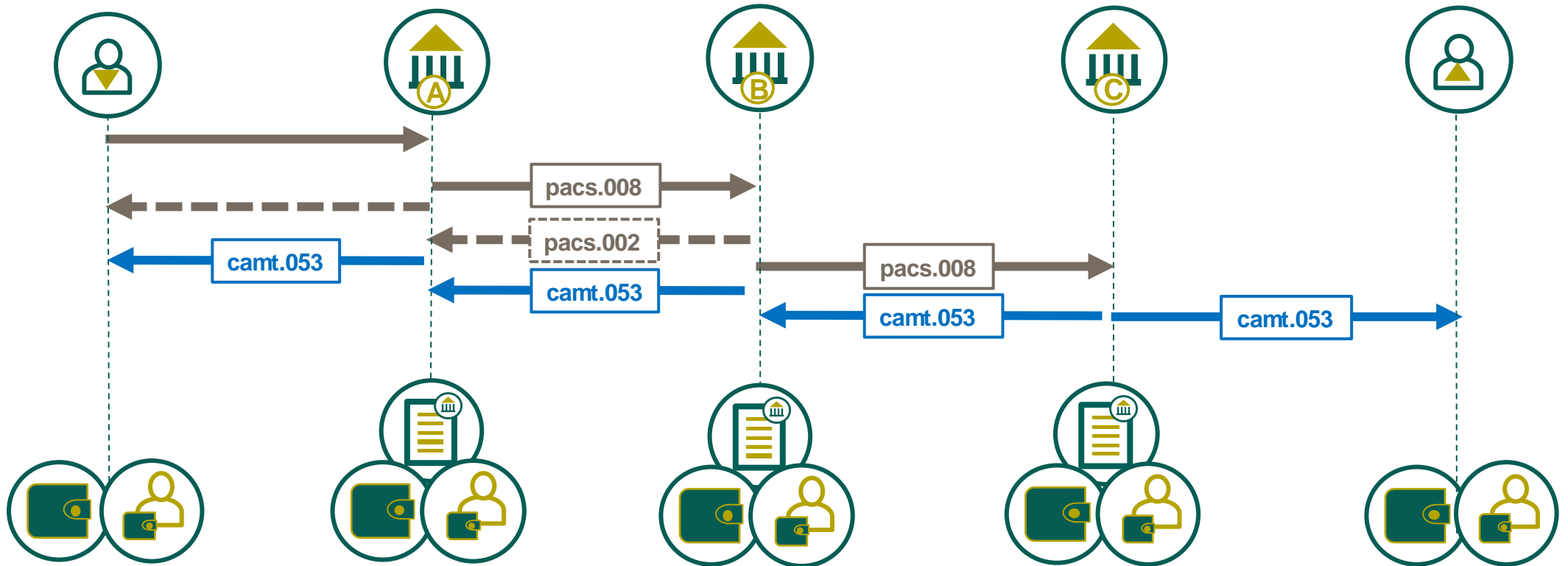

Role of the Creditor Agent and Creditor in the payment changes by description in the Bank to Customer Statement message to Account Servicer and Account Owner. Whereby the statement is send by the Account Servicer to the Account Owner and or authorised party. This message is used to inform the account owner, or authorised party, of the entries booked to the account, and to provide the owner with balance information on the account at a given point in time.

High level camt.053 basic translation to the legacy MT 940

Like the legacy MT Statement messages, the camt.053 Bank to Customer Account Statement is constrained in CBPR+ by the FINplus service's message size. Account Owner who needs to translate the camt.053 into the legacy MT 940 format has several considerations for the Account Serving Institution.



ISO 20022 message element



MT Field Name & (Tag option)



Statement Identification



Legal Sequence Number



Statement Pagination



Account (Identification)



Balance Type

OPBD (with no *Sub Type* INTM)

OPBD (with *Sub Type* INTM)



Entry



Balance Type

CLBD (with no *Sub Type* INTM)

CLBD (with *Sub Type* INTM)

needed to create MT 940 Field 20 Transaction Reference Number

needed to create MT 940 Field 28C Statement Number

needed to create MT 940 Field 28C Sequence Number

needed to create MT 940 Field 25a Account Identification

needed to create MT 940 Field 60F (first) Opening Balance

needed to create MT 940 Field 60M (intermediate) Opening Balance

used to create MT 940 Field 61 Statement Line



Note up to 190 **Entry** occurrences will translate into a basic MT 940 (inside of the existing MT 940 message size)

needed to create MT 940 Field 62F (final) Closing Balance

needed to create MT 940 Field 62M (intermediate) Closing Balance

High level MT 935 basic mapping to the camt.053

Interest rate changes on an account can be communicated using the camt.053. An Account Serving Institution who is considering the camt.053 to communicate such rate changes to the Account Owner may find the following comparison against the legacy MT 935 useful. However, compared the camt.053 to legacy MT, using the camt.053 is like combining the information of both the MT 935 and MT 940 together into one message.



MT Field Name & (Tag option)



ISO 20022 message element

- Transaction Reference Number (Field 20)
- **Sequence**
- Further Identification (Field 13C) **NOT MAPPED**
- Account Identification (Field 25)
- Effective Date of New Rate (Field 30)
- New Interest Rate (Field 37H)
- Sender To Receiver Information (Field 72) **NOT MAPPED**

- **Group Header / Message Identification**
- **Statement / Account / Identification**
- **Statement / Interest / From Date**
- **Statement / Interest / Rate**

*Note - various other elements are mandatory in the camt.053 which are not derived from the payment instruction including; **Message Identification, Creation Date Time, Statement Identification, Statement Pagination, Balance, Credit Debit Indicator, Status, Bank Transaction Code**.. often these data elements and potentially other optional elements will be generated by the bank application when creating the reporting message.*

Group Header



camt.053 Bank to Customer Account Statement - Message Identification

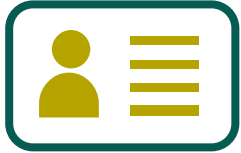

Each ISO 20022 cash management reporting message has a *Message Identification* element, located in the Group Header. This **35 character** identifier is a point-to-point reference used to unambiguously identify the message.

For Cash Management (camt) messages the *Message Identification* has no exact equivalent in the legacy MT Customer Statement message. However, the *Transaction Reference Number* (Field 20) could be considered a similar comparison.

Group Header ➤ Message Identification

camt.053 Bank to Customer Account Statement – Creation DateTime

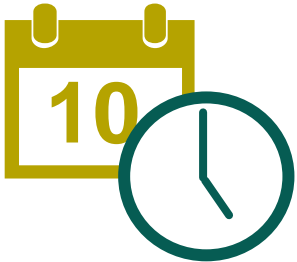

CBPR+ usage guidelines mandate the time zone that the time represents as an offset against Universal Time Coordinated (UTC):

Local time with UTC offset `YYYY-MM-DDThh:mm:ss.sss+/-hh:mm`

- For example: `2002-10-10T12:00:00-05:00` (noon/midday on 10 October 2002, Central Daylight Savings Time as well as Eastern Standard Time in the U.S.)



All CBPR+ time elements need offset against UTC. Milliseconds are optional.

Group Header ▶ Creation Date Time

camt.053 Bank to Customer Account Statement – Message Recipient

Min 0 – Max 1

The Bank to Customer Statement **Message Recipient** nested element provides details of the party authorised by the *Account Owner* to receive the Account Statement.

This element **should only** be used to identify the *Message Recipient* when different from the account owner, which is implied by the usage of **COPY** in the *Copy Duplicate Indicator* within the nested **Statement** element.



Where **Message Recipient** is used the nested:

- **Name** Min 0 – Max 1
- **Postal Address** Min 0 – Max 1
- **Identification** Min 0 – Max 1
- **Contact Details** Min 0 – Max 1

may be used to capture information related to this party.

Group Header ▶ Message Recipient ▼

Name

▶ Postal Address

⊗ Identification

▶ Contact Details

585



camt.053 Bank to Customer Account Statement – Original Business Query

The Bank to Customer Statement **Original Business Query** ^{Min 0 – Max 1} element identifies a query to generate a report, for example a camt.060 Account Reporting Request.



Where **Original Business Query** is used the original **Message identification** ^{Min 1 – Max 1} (i.e., the message identification of the camt.060 message) is required. Original **Message Name identification** and Original **Creation Date Time** ^{Min 0 – Max 1} may also be provided. ^{Min 0 – Max 1}

Group Header ▶ Original Business Query ▼

Message Identification

Message Name Identification

Creation Date Time 586

camt.053 Bank to Customer Account Statement – Additional Information

Min 0 – Max 1

The Bank to Customer Statement **Additional Information** element represents further details related to the account statement.



Where the camt.053 is used for various end of cycle statement reporting (statement periods) the follow codes may be used to distinguish the different camt.053 usage:

/EODY/ for End of Day - Daily Statement

/EOWK/ for End of Week - Weekly Statement

/EOMH/ for End of Month - Monthly Statement

/EOYR/ for End of Year - Yearly Statement



Additional Information is a textual element restricted in CBPR+ to 500 characters.

Group Header ▶ Additional Information

Statement



camt.053 Bank to Customer Account Statement - Statement

Min 1 – Max 1

The Bank to Customer Account Statement **Statement** nested element reports information related to an account, most typically associated with account balances, and accounting entries (where entries have been processed on the account).



The *Statement* element has been restricted to one statements. To report additional account statements to the Account Owner this would need to occur via a separate message in a similar way to the legacy MT 940 or MT 950.



It should also be noted the Account Statement message is modelled identically to the Account Report (camt.052) therefore where an intraday transaction report is used the content can be capture identically to the statement at the close of the business day, in the Account Statement (camt.053)

Statement >

camt.053 Bank to Customer Account Statement – Statement sent over multiple messages

Similar to the legacy MT Statement messages the camt.053 Bank to Customer Account Statement is constrained in CBPR+ by the FINplus service's message size. Consideration therefore need to be given to identifying; the **statement order**, the **statement correlation** and the **last statement page**.

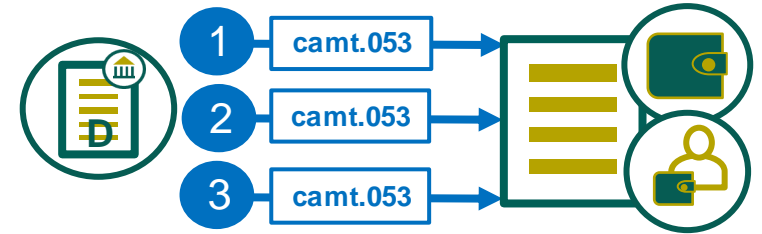

1 **Statement Pagination**
 Page 1
 Last Page No
 Electronic Sequence Number 16
 Legal Sequence Number 3
 Account
 Id 12345
 Currency EUR
 Balance
 OPBD (Opening Booked)
 CLBD (Closing Booked)
 Sub Type INTM (Interim)

2 **Statement Pagination**
 Page 2
 Last Page No
 Electronic Sequence Number 16
 Legal Sequence Number 3
 Account
 Id 12345
 Currency EUR
 Balance
 OPBD (Opening Booked)
 Sub Type INTM (Interim)
 CLBD (Closing Booked)
 Sub Type INTM (Interim)

3 **Statement Pagination**
 Page 3
 Last Page Yes
 Electronic Sequence Number 16
 Legal Sequence Number 3
 Account
 Id 12345
 Currency EUR
 Balance
 OPBD (Opening Booked)
 Sub Type INTM (Interim)
 CLBD Closing Booked

Closing Interim = Opening Interim of next statement

Closing Interim = Opening Interim of next statement

Statement Order: identifying the order in which statements should be processed or reconstituted. Options:

Statement Pagination

Statement Correlation: identifying statement which relate to each other for a given statement period. Options:

Legal Sequence Number
 Electronic Sequence Number
 Account (Identifier and Currency)

Last Statement: identifying when no further statements for a given period are expected i.e. period statement in finalised. Options:

Statement Pagination, Last Page Indicator
Balance Type CLBD (with no Sub Type INTM)



Balance Sub Type code **INTM** is essential for identifying Interim Opening and Interim Closing balances in a statement sent over more than 590 one message. Balance Type OPBD and CLBD without Sub Type code identify the first (OPBD) and last (CLBD) statement page..

camt.053 Bank to Customer Account Statement - Identification

Min 1 – Max 1

The Bank to Customer Statement message **Identification** provides a mandatory element to identify the statement



Unique reference assigned by the account servicer to unambiguously identify the account statement. Directly comparable with the *Transaction Reference Number* (Field 20) of the legacy MT statement message.

Statement  Identifier

camt.053 Bank to Customer Account Statement – Statement Pagination

The Bank to Customer Statement message **Statement** ^{Min 1 – Max 1} **Pagination** element provides the page number of the statement.





Statement ^{Min 1 – Max 1} **Pagination** includes the **Page Number** ^{Min 1 – Max 1} and **Last Page indicator** ^{Min 1 – Max 1} elements.

For example a *Page Number* of 2 represents the current account statement, being the second page of the and implying a previous account statement page had been sent. The *Last Page indicator* further implies whether more pages are expected



Note: Where Page Number is equal to 1 a Balance Type OPBD (Opening Booked) must be provided, without a sub type of INTM (Interim). Whereas if the Page Number is greater than 1 a Balance Type OPBD (Opening Booked) must be provided, with a sub type of INTM (Interim). Where Last Page Indicator is true a Balance Type CLBD (Closing Booked) must be provided, without a sub type of INTM (Interim). Whereas if the Last Page Indicator is false a Balance Type CLBD (Closed Booked) must be provided, with a sub type of INTM (Interim).

Statement  Statement **Pagination** 

Page Number

Last Page indicator



camt.053 Bank to Customer Account Statement - Electronic Sequence Number

Min 0 – Max 1

The Bank to Customer Statement message **Electronic Sequence Number** allows the *Account Servicer* to assign a number to each statement which should increment by 1 for each electronic statement report sent.



This element allows easy recognition of the statement order, equivalent to the legacy Field 28C Statement Number. The sequence should increment for each camt.053 electronic statement sent to the Account Owner or Authorised Party this number must be the same value where the statement continues over multiple pages (*Statement Pagination*) of the statement for a give account on a given day.

Should this sequence number be reset by the *Account Servicer*, this should not occur more frequently than once a year. Likewise, this 18 digit counter could be incremented to its maximum value before it's reset.



The use of Electronic Sequence Number and the sequence reset logic should be bilaterally agreed between the *Account Servicer* and the *Account Owner*. Either **Electronic Sequence Number** or **Legal Sequence Number** Should be provided to enable the identification of a statement number.

Statement  Electronic Sequence Number

camt.053 Bank to Customer Account Statement - Reporting Sequence

The Bank to Customer Statement message **Reporting Sequence** ^{Min 0 – Max 1} specifies the choice of identification sequences. This can be used as an alternative to the **Statement Pagination** or **Electronic Sequence Number** as a way to identify the statement order, which is not confined to numeric values. 

Where used the **Reporting Sequence** mandate a choice of nested element:

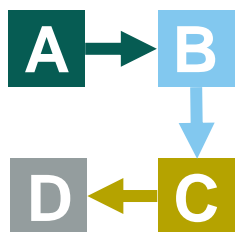

- **From Sequence** identifies the start of a sequence range. ^{Min 1 – Max 1}
- **To Sequence** identifies the end of a sequence range. ^{Min 1 – Max 1}
- **From To Sequence** identifies the start and end of a sequence range. ^{Min 1 – Max *}
- **Equal Sequence** identifies a sequence. ^{Min 1 – Max *}
- **Not Equal Sequence** identifies a sequence to be excluded. ^{Min 1 – Max *}

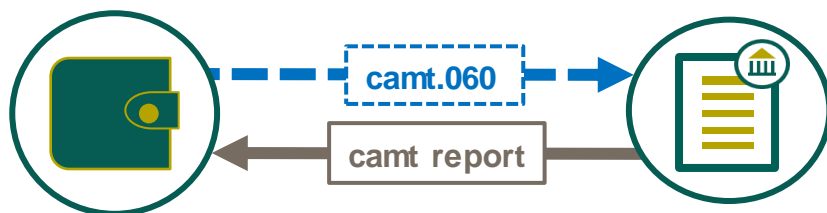

The Reporting Sequence may be provided in the camt.060 Account Reporting request to specify, for example, a range of Statements to be sent. More traditionally Account Statements are generated automatically on an end of day cycle.

Statement  Report Sequence 

camt.053 Bank to Customer Account Statement - Legal Sequence Number

Min 0 – Max 1

The Bank to Customer Statement message **Legal Sequence Number** allows the *Account Servicer* to assign a number to each statement which should increment by 1 for each statement report sent.



Where the statement is reported using multiple camt.053 messages for a given statement period the **Legal Sequence Number** must be the same number in each statement message, as it can be used to correlate the statements.

Where a paper statement is a legal requirement, it may have a number different from the electronic sequential number. In this case the **Legal Sequence Number** element represents the sequence number of the paper statement.



Either **Electronic Sequence Number** or **Legal Sequence Number** must be provided to enable the identification of a statement number.

Statement  Legal Sequence Number

camt.053 Bank to Customer Account Statement - Creation Date Time

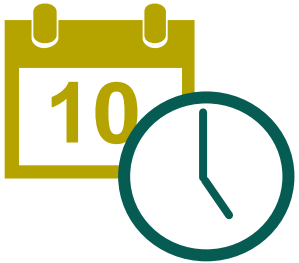

CBPR+ usage guidelines mandate the time zone that the time represents as an offset against Universal Time Coordinated (UTC):

Local time with UTC offset `YYYY-MM-DDThh:mm:ss.sss+/-hh:mm`

- For example: `2002-10-10T12:00:00-05:00` (noon/midday on 10 October 2002, Central Daylight Savings Time as well as Eastern Standard Time in the U.S.)



All CBPR+ time elements need offset against UTC. Milliseconds are optional.

camt.053 Bank to Customer Account Statement – From To Date

Min 0 – Max 1

The Bank to Customer Statement message **From to Date** allows the *Account Servicer* to specify the start date time and end date time applicable to the statement.

Where **From to Date** is used the **From Date Time** and **To Date Time** become mandatory elements.

Min 1 – Max 1

Min 1 – Max 1

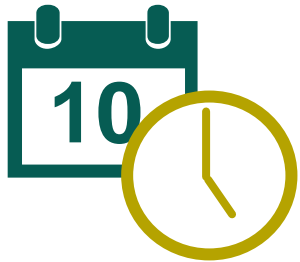

CBPR+ usage guidelines mandate the time zone that the time represents as an offset against Universal Time Coordinated (UTC):

Local time with UTC offset YYYY-MM-DDThh:mm:ss.sss+/-hh:mm

- For example: 2002-10-10T12:00:00-05:00 (noon/midday on 10 October 2002, Central Daylight Savings Time as well as Eastern Standard Time in the U.S.)



All CBPR+ time elements need offset against UTC. Milliseconds are optional.



Statement 

From to Date

To Date Time

camt.053 Bank to Customer Account Statement – Copy Duplicate Indicator

Min 0 – Max 1

The Bank to Customer Statement message **Copy Duplicate Indicator** is used as a choice to identify additional statement from the original sent to the Account Owner.

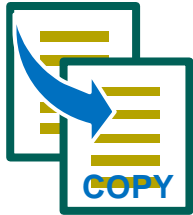

COPY is used when a copy of the statement is sent to an Authorised Third Party, such as a company head office, parent entity, or an institution providing additional service such as liquidity sweeping or statement consolidation.

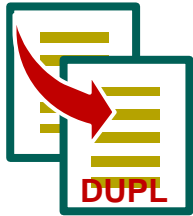

DUPL is used when a duplicate of the statement is sent to the Account Owner, this resubmission may have been requested using the camt.060 or an alternative channel such as via internet banking or customer service request.

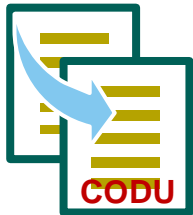

CODU is used when a duplicate of a statement copy is sent to an Authorised Third Party, this resubmission may have been requested using the camt.060 or an alternative channel such as via internet banking or customer service request. It may also be requested by the Account Owner on behalf of the Authorised Third Party, depending on the arrangement in place with the Account Servicer.

Statement  Copy Duplicate Indicator  

camt.053 Bank to Customer Account Statement – Reporting Source

Min 0 – Max 1

The Bank to Customer Statement message **Reporting Source** allows the *Account Servicer* to define the source of the statement, typically associated with an application.

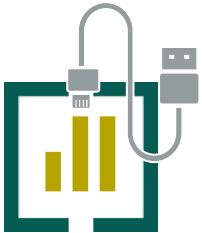

Reporting Source utilises the external Reporting Source code list. For example **ACCT** represents a statement or report based on accounting data, whereas **DEPT** represents a cash or deposit system.

Where the source of the statement is functionally required by the consumer of the statement i.e., the *Account Owner* or *Authorised Third Party*, the codes used should be bilaterally agreed.

Statement  Reporting Source 

camt.053 Bank to Customer Account Statement - Account

The Bank to Customer Statement message **Account** ^{Min 1 – Max 1} provides nested elements to identify the account for which debit and credit entries have been made. The following two mandatory elements are nested beneath *Account*.

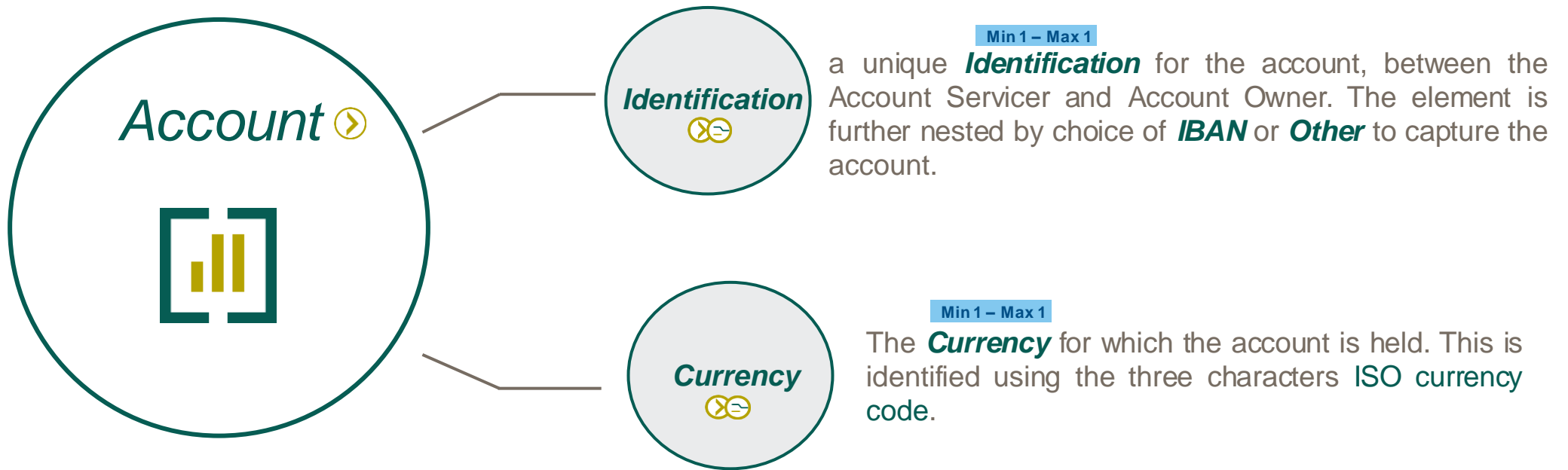

Statement > Account >

camt.053 Bank to Customer Account Statement - Account (continued)

Min 1 – Max 1

Min 0 – Max 1

The Bank to Customer Statement message mandatory **Account** also provides a number of optional nested element to identify the account for which debit and credit entries have been made.

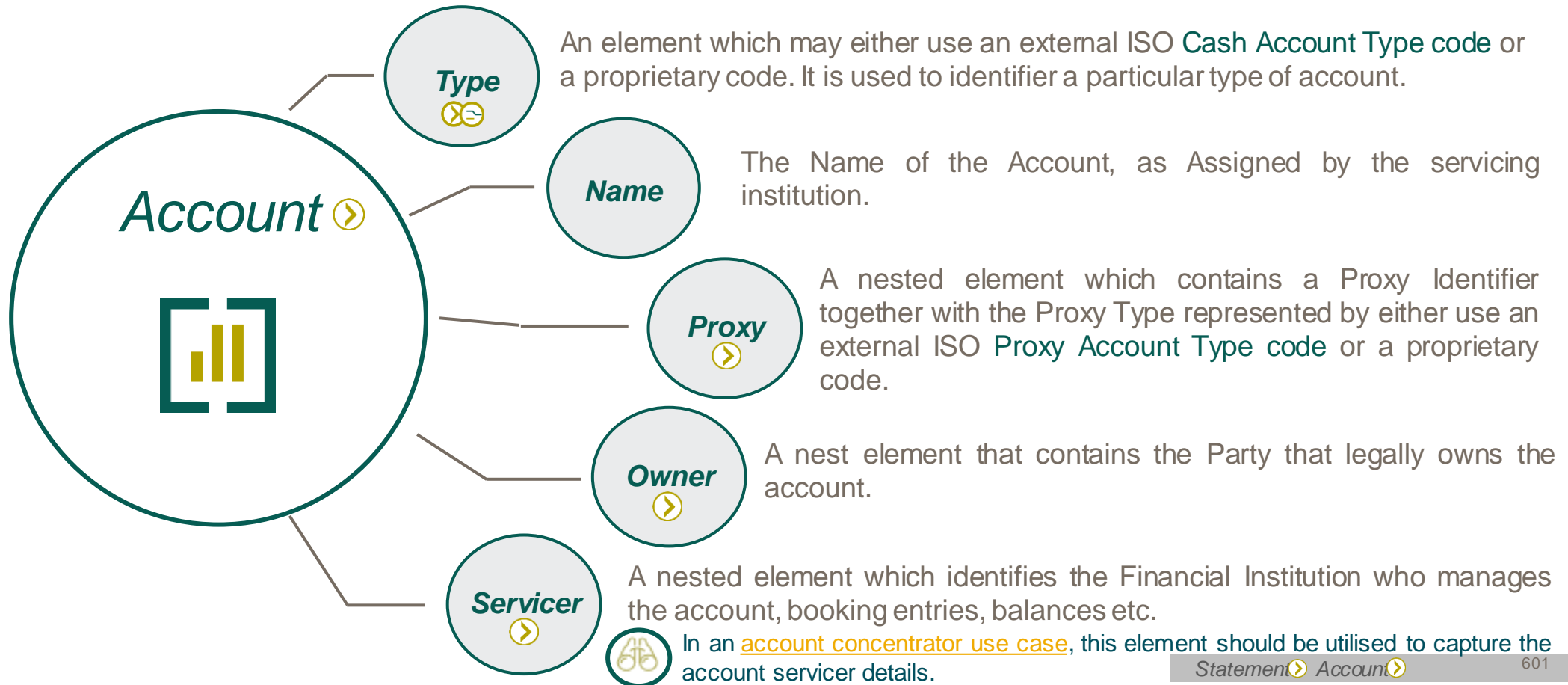

camt.053 Bank to Customer Account Statement – Related Account

Min 0 – Max 1

The Bank to Customer Statement message **Related Account** allows the identification of a related parent account for the account statement. For example, sweeping, pooling or virtual account for which the statement is produced can identify the parent account they hierarchically relate to.



When **Related Account** is utilized, like **Account**, the **Identification** and **Currency** element become mandatory.

Additionally the nested **Type** element, **Name** and nested **Proxy** element are optionally available.

Min 1 – Max 1

Min 1 – Max 1

Min 0 – Max 1

Min 0 – Max 1

Min 0 – Max 1



Related Account uses a variety of common elements described in more detail within the **Account** section.

Statement > Related Account

Identification

Type

Currency

Name

602

Proxy

camt.053 Bank to Customer Account Statement – Interest

Min 0 – Max *

The Bank to Customer Statement message **Interest** provides interest information that applies to the account.

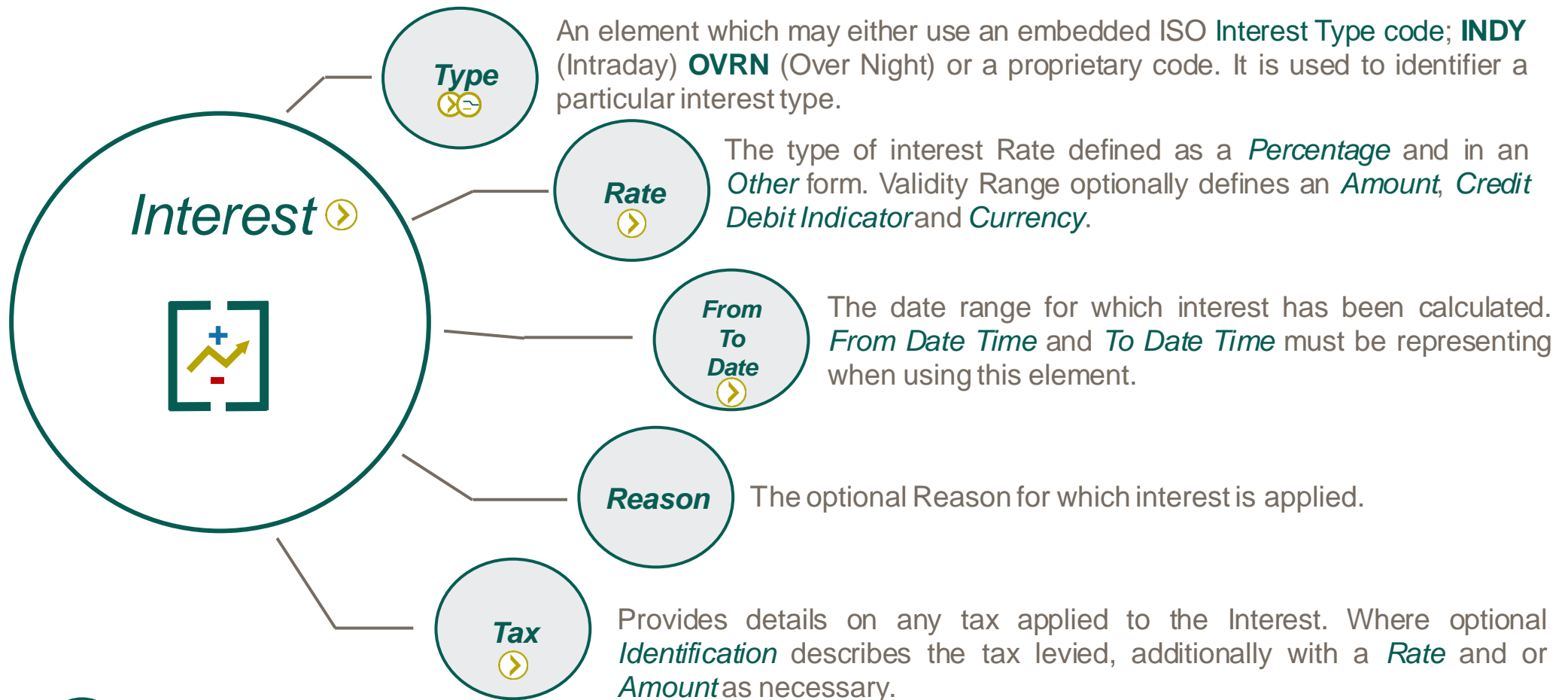

Note interest reported on an account is commonly associated to the legacy MT 935

camt.053 Bank to Customer Account Statement - Balance

Min 1 – Max *

The Bank to Customer Statement message mandatory **Balance** provides nested element to define the account balance at a specific point in time. The following four elements nested beneath **Balance** are mandatory

Min 1 – Max 1

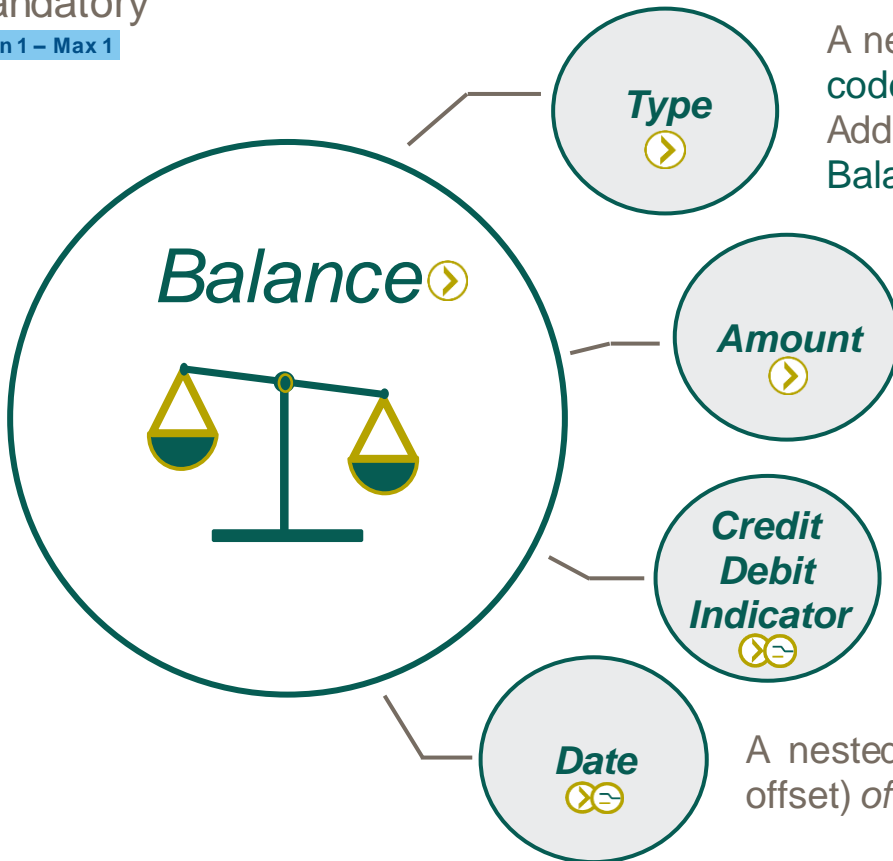

A nested element which may either use an external ISO **Balance Type code** or a proprietary code. For example, OPAV – Opening Available. Additionally, a Sub Type represented by either use an external ISO **Balance Sub Type code** or a proprietary code, may be used.



Balance Sub Type code INTM is essential for identifying opening and closing balances in a statement sent over more than one message.

Balance amount.

Embedded code CRDT (Credit balance) DBIT (Debit balance)

A nested element representing the **Date** and the **DateTime** (with UTC offset) of the balance

Statement > Balance ✓



The Balance element is unlimited (Max *) whereby more that one Type of balance may be reported

camt.053 Bank to Customer Account Statement – Balance Type code

Balance Type code are used within the nested *Balance* element to represent the type/s of balance being reported. In comparison the legacy MT 940 utilizes different Fields and Tag options to represent a number of these Balance Types. The below extract from the externalised ISO *Balance Type* code list compares the code with the population of the equivalent information in the Legacy MT 940 Customer Statement.

Code	Sub Type	Name	Definition	MT 940 Comparison
CLAV		ClosingAvailable	Closing balance of amount of money that is at the disposal of the account owner on the date specified.	Field 64
CLBD		ClosingBooked	Balance of the account at the end of the pre-agreed account reporting period. It is the sum of the opening booked balance at the beginning of the period and all entries booked to the account during the pre-agreed account reporting period.	Field 62F
	INTM	ClosingBooked (Interim)	Interim Balance of the account at the end of the pre-agreed account reporting page. It is the sum of the opening booked balance at the beginning of the period and all entries booked to the account during the pre-agreed account reporting page.	Field 62M
FWAV		ForwardAvailable	Forward available balance of money that is at the disposal of the account owner on the date specified.	Field 65
INFO		Information	Balance for informational purposes.	No equivalent
ITAV		InterimAvailable	Available balance calculated in the course of the account servicer's business day, at the time specified, and subject to further changes during the business day. The interim balance is calculated on the basis of booked credit and debit items during the calculation time/period specified.	No equivalent
ITBD		InterimBooked	Balance calculated in the course of the account servicer's business day, at the time specified, and subject to further changes during the business day. The interim balance is calculated on the basis of booked credit and debit items during the calculation time/period specified.	No equivalent
OPAV		OpeningAvailable	Opening balance of amount of money that is at the disposal of the account owner on the date specified.	No equivalent
OPBD		OpeningBooked	Book balance of the account at the beginning of the account reporting period. It always equals the closing book balance from the previous report.	Field 60F
	INTM	OpeningBooked (Interim)	Interim Book balance of the account at the beginning of the account reporting page. It always equals the closing book balance from the previous report page.	Field 60M
PRCD		PreviouslyClosedBooked	Balance of the account at the previously closed account reporting period. The opening booked balance for the new period has to be equal to this balance. Usage: the previously booked closing balance should equal (inclusive date) the booked closing balance of the date it references and equal the actual booked opening balance of the current date.	Field 60F
XPCD		Expected	Balance, composed of booked entries and pending items known at the time of calculation, which projects the end of day balance if everything is booked on the account and no other entry is posted.	No equivalent



[Take me to an implementation example involving Balance Type codes](#)

camt.053 Bank to Customer Account Statement – Balance (continued)

Min 1 – Max *

The Bank to Customer Statement message mandatory **Balance** also provides the optional set of nested element to define a **Credit Line**

Min 0 – Max *

The true/false Boolean of **Included** to clearly determine whether the Credit Line Amount is included in the balance is mandatory in the set of Credit Line element.

Additionally, the following optional nested element may be used to identify:

- The **Type** of Credit Line, which may either use an external ISO Credit Line Type code or a proprietary code.
- A set of elements to provide **Credit Line** details
- The **Amount** (Currency and Amount) of the Credit Line
- The **Date** (nested as Date, DateTime) of the Credit Line, provided to distinguish where multiple Credit Line exist.



The final optional nested element within **Balance** is the **Availability** of the booked amount i.e., when it is available to be accessed.



The **Credit Line** element is unlimited (Max *) whereby more than one **Credit Line** may be reported, the **Date** becomes an important element to distinguish between different Credit Lines.

Statement	Balance
Type	
Credit Line	
Amount	
Credit Debit Indicator	
Date	
Availability	

camt.053 Bank to Customer Account Statement – Transaction Summary

Min 0 – Max 1

The Bank to Customer Statement message optional **Transaction Summary** provides a set of nested element to summarize entry information. Where the statement is reported using multiple camt.053 messages for a given statement period the **Transaction Summary** should only be included on the opening Statement message (*Balance Type* OPBD with no *Balance Sub Type*) summarizing the whole Statement Report (entire statement period) This aligns with the Common Global Implementation (CGI) where a **Transaction Summary**, if provided, would appear before the first *Entry* elements.



Each of the following element allow an optional total of entries either as a **Number of Entries** and or as a **Sum**.

- **Total Entries**
- **Total Credit Entries**
- **Total Debit Entries**
- **Total Entries Per Bank Transaction Code**

Min 0 – Max *

In addition to the **Number of Entries** and **Sum**, the **Total Entries Per Bank Transaction Code** requires the **Bank Transaction Code** element and optionally allows a variety of other optional elements.

Min 1 – Max 1



The **Total Entries Per Bank Transaction Code** element is unlimited (Max *) whereby more that one **Bank Transaction Code** may be summarised.

Statement > Transaction Summary >

Total Entries >

Total Credit Entries >

Total Debit Entries >

Total Entries per Bank Transaction Code >

camt.053 Bank to Customer Account Statement – Entry

The Bank to Customer Statement message optional **Entry** provides a significant variety of nested elements to represent the details associated with each **Entry**. For active accounts which have entries posted across them, this set of nested elements is arguably the most relevant for the account owner and in many way is comparable with the MT 940 Field 61 Statement Line.

Unlike the legacy MT Statement messages, the camt.053 has a number of dedicated elements to capture a variety of entry level data.

It also has a number of enhancements on the legacy MT Statement message where parties in the payment and customer remittance information, as examples, can provided to the *Account Owner*.

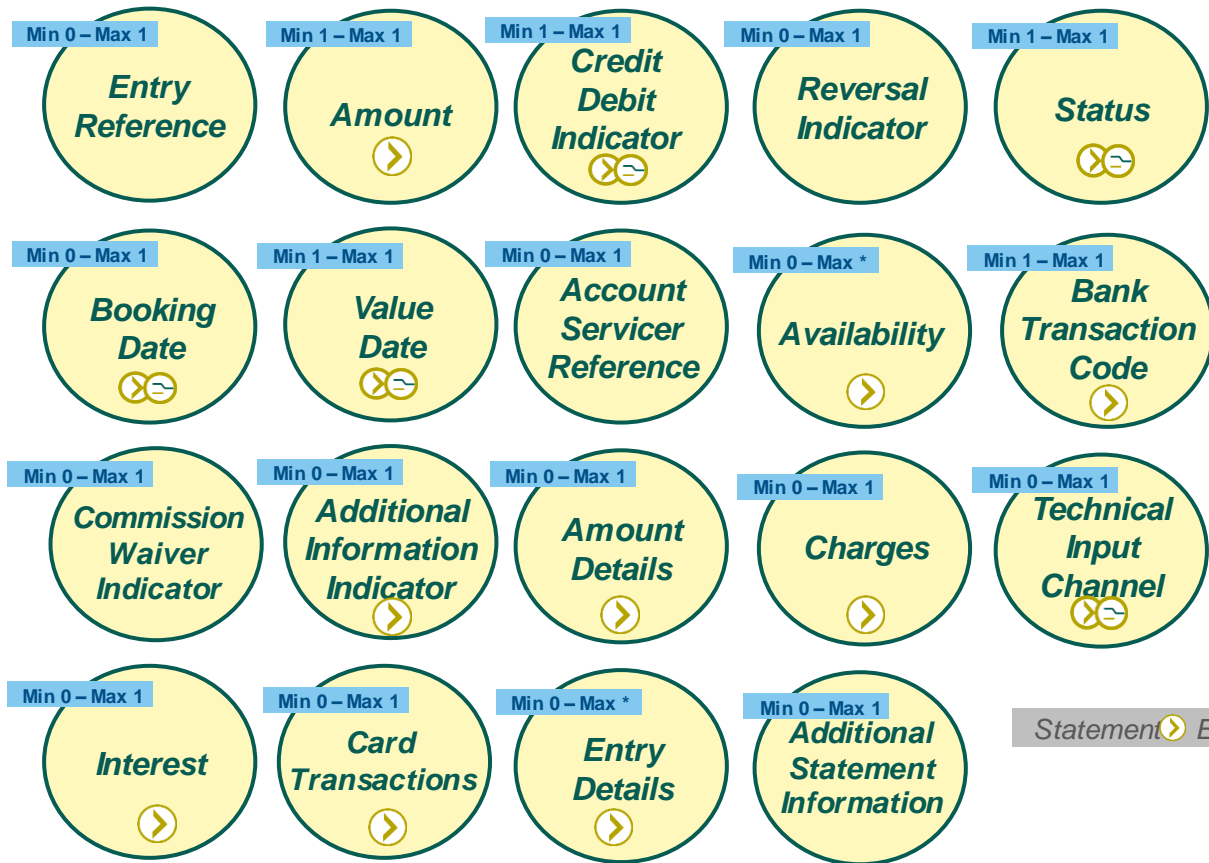

Statement > Entry >

camt.053 Bank to Customer Account Statement – Entry (continued)

Min 0 – Max 1

Entry Reference

Unique reference for the booking entry, created by the Account Servicing Institution as a reference they assign to identify the entry posted to the account.

Min 1 – Max 1

Amount

Mandatory element representing the currency and amount of the entry. This can be compared to Field 61 subfield 4 and 5 of the legacy MT 940.



Amount element within CBPR+ allows up to 18 digits unlike the payment messages. It allows entries reported for non CBPR+ transactions to be reported.

Min 1 – Max 1

Credit Debit Indicator

Mandatory element indicating whether the **Amount** entry is a **DBIT** (Debit) or **CRDT** (Credit) to the account. This can be compared to Field 61 subfield 3 of the legacy MT 940.

Min 0 – Max 1

Reversal Indicator

Indicates whether the entry is a result of a reversal. for example, an entry related to a pacs.004 Payment Return or reverses an error such as an incorrect value date applied to the entry. Where the **Reversal Indicator** is **Yes**, the **Credit Debit Indicator** should be the opposite of the original entry, for example original **Credit Debit Indicator** of **CRDT** would expect a reversal entry **Credit Debit Indicator** of **DBIT**. This can be compared to Field 61 subfield 3 of the legacy MT 940 where a reversal code may be used.



camt.053 Bank to Customer Account Statement – Entry (continued)

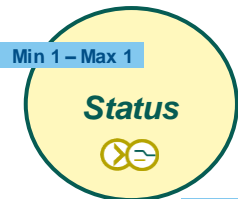

Mandatory element representing the status using an external ISO **Entry Status** code for example BOOK is used to confirm the entry is booked.



Status BOOK is the only status that can be reversed using the **Reverse Indicator**

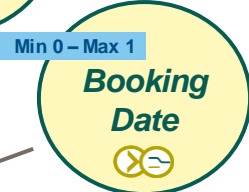

Mandatory choice of **Date** or **Date Time** the entry was posted to the **Account**. This can be compared to Field 61 subfield 2 of the legacy MT 940.

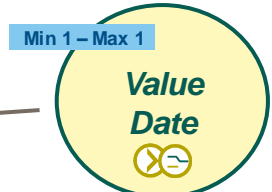

Mandatory choice of **Date** or **Date Time** the entry become available. This can be compared to Field 61 subfield 1 of the legacy MT 940.



Noting CBPR+ usage guidelines mandate the time zone that the **Date Time** represents as an offset against Universal Time Coordinated (UTC)

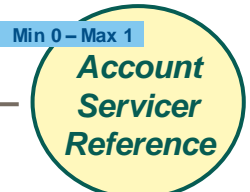

Additional optional Reference typically assigned by the Account Servicer's payment engine or accounting platform. This reference would be used to query an entry. This can be compared to Field 61 subfield 8 of the legacy MT 940.

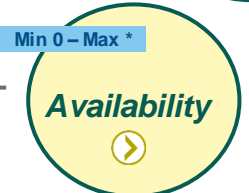

Indicates when the booked amount is available i.e., when it is available to be accessed.

Statement > Entry >



camt.053 Bank to Customer Account Statement – Entry (continued)

Min 1 – Max 1

Bank Transaction Code



The **Bank Transaction Code** is designed to deliver a harmonized set of codes, which should be applied in bank-to-customer cash account reporting information. The bank transaction code information allows the **account servicer** to correctly report a transaction, which in its turn will help **account owners** to perform their cash management and reconciliation operations.

The structure of the Bank Transaction Code has three levels:

Domain: Highest definition level to identify the sub-ledger. The domain defines the business area of the underlying transaction e.g., payment, securities etc.)

Family: Medium definition level e.g. type of payment; credit transfer, direct debit etc.

Sub-family: Lowest definition level e.g. type of cheques; draft etc.

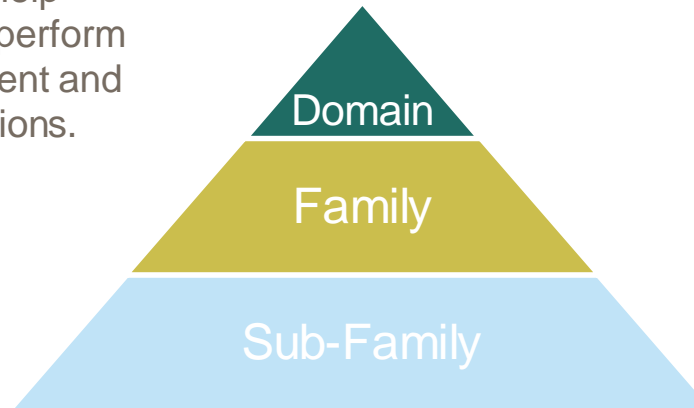

Bank Transaction Codes are an external code set defined in the *Bank Transaction Code combinations* external code sets.

Statement > Entry > Bank Transaction Code

Domain

Family 611

Sub Family



camt.053 Bank to Customer Account Statement – Bank Transaction Code descriptions

Min 1 – Max 1

Payments Domain Families		
1. Received Credit Transfers	Receivable Credit Transfers are instructions to receive an amount of money from a del the account owner. The receivable credit transfers are related to transactions received t account owner.	
2. Issued Credit Transfers	Payable Credit Transfers are instructions to transfer an amount of money by the accou to a creditor. The payable credit transfers are related to instructions sent by the accoun	
3. Received Cash Concentration	Transaction is related to incoming cash movements that are related to cash managemer activities initiated by the owner of the sending account to optimise the return on the av funds.	
4. Issued Cash Concentration	Transaction is related to outgoing cash movements that are related to cash managemen activities initiated by the owner of the account to optimise the return on the available f	
5. Received Direct Debits	The Received Direct Debit transactions are related to instructions received by the acco to debit the account.	
6. Issued Direct Debits	The Issued Direct Debit transactions are related to instructions sent by the account owi collect an amount o	
7. Received Cheques	Transaction is relat from the cheque dr:	
8. Issued Cheques	Transaction is relat	
Sub-Families for both Received and Issued Credit Transfers		
	Sub-Family	Definition
	Internal Book Transfer	Transaction is a transfer between –two different accounts within the same bank.
	Standing Order	Transaction is a standing order. A standing order is an instruction given by a party having authority on the debtor’s account to debit, i.e. either debit account owner or originating p; account servicer, to process credit transfers at specified intervals during an implicit or exp period of time. It is given once, and is valid for an open or closed period of time.
	Cross-Border Standing Order	Transaction is a cross-border standing order
	SEPA Credit Transfer	Transaction is a SEPA credit transfer
	Domestic Credit Transfer	Transaction is a in-country domestic currency credit transfer
	Cross-Border Credit Transfer	Transaction is a cross-border credit transfer
	Credit Transfer with agreed Commercial Information	Transaction is a credit transfer including commercial information, i.e. additional informat agreed between the sender and the receiver.
	Financial Institution Credit Transfer	Transaction is a financial institution credit transfer, i.e. the debtor and creditor are financi institutions.
	Priority Credit Transfer	Transaction is a credit transfer defined with higher priority, eg a PRIEURO credit transfe:
	Payroll/Salary Payment	Transaction is related to the payment of a payroll salary
	Cross-border	Transaction is related to the payment of a cross-border payroll salary

The description of **Bank Transaction Codes** are available to download from the ISO20022.org external code list page. These include the descriptions for Payments Domain Families and sub-families for both Received and Issued Credit Transfers.

https://www.iso20022.org/external_code_list.page



camt.053 Bank to Customer Account Statement – Bank Transaction Code combinations

Bank Transaction Code - all permitted combinations of the BTC code sets							
All codes in light grey are defined as the generic codes available for all Domains and Families							
Domain	Family	SubFamily	Domain Code	Family Code	SubFamily Code	Status	Status Date
Payments	Issued Credit Transfers	Cross-Border Credit Transfer	PMNT	ICDT	XBCT	New	27/4/2009
Payments	Received Credit Transfers	Cross-Border Credit Transfer	PMNT	RCDT	XBCT	New	27/4/2009

Bank Transaction Codes are an external code set defined in the *Bank Transaction Code combinations* external code sets.

As an example a debit statement transaction which relates to a cross-border payment initiated from an account would be represented by:

Domain	Family	Sub-Family
PMNT (Payment)	ICDT (Issued Credit Transfer)	XBCT (Cross-Border Credit Transfer)



camt.053 Bank to Customer Account Statement – Entry (continued)

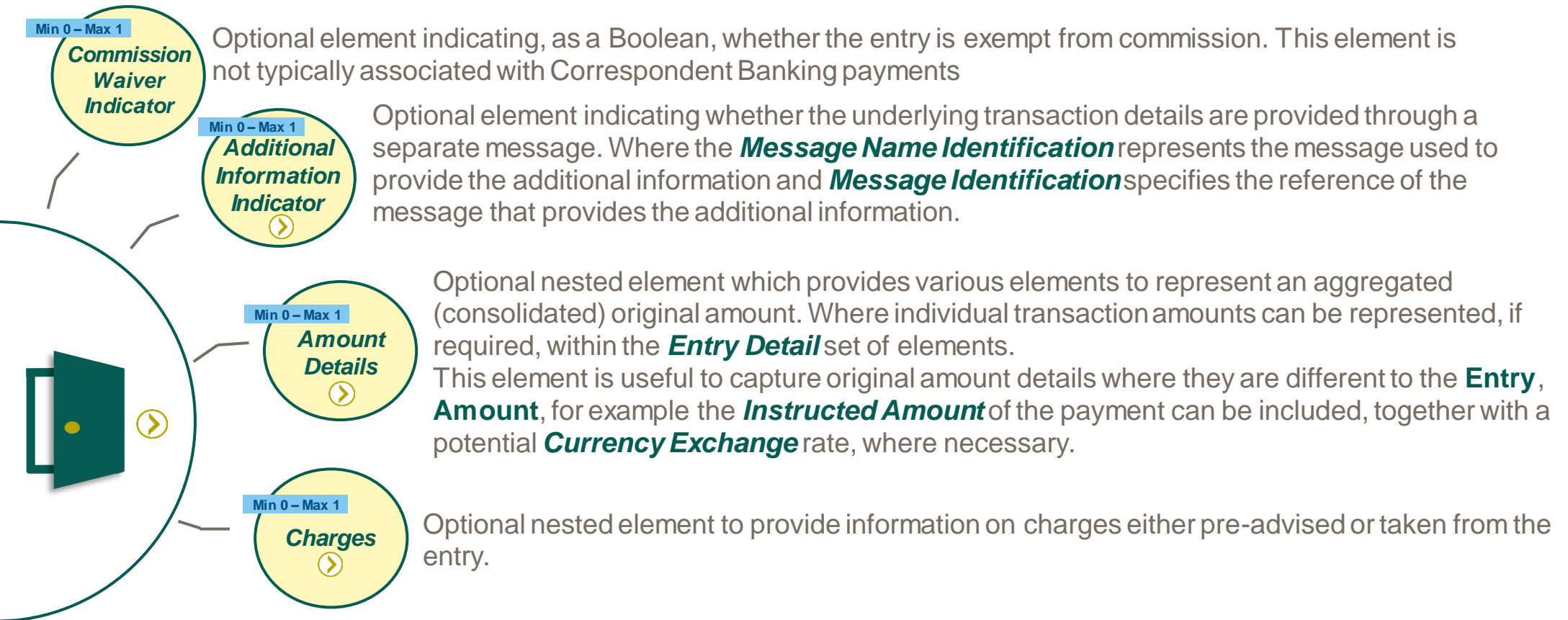

Statement > Entry >

camt.053 Bank to Customer Account Statement – Entry (continued)

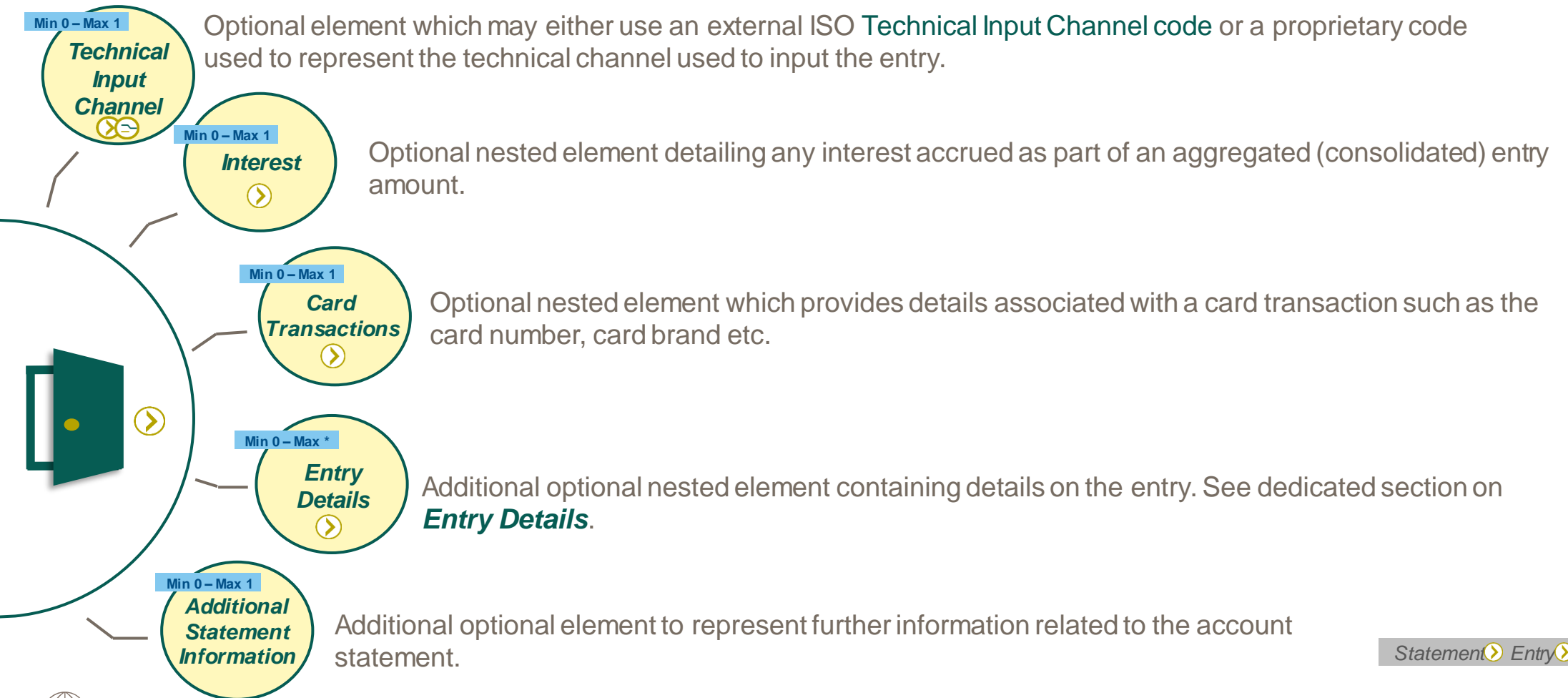

Statement ▶ Entry ▶



camt.053 Bank to Customer Account Statement – Entry Details

The Bank to Customer Statement message optional *Entry Details* provides a variety of nested elements to represent the details associated with each *Entry*.

Min 0 – Max *



Batch provides details on batched transactions such as the total ***Number of Transactions*** the batched entry (sometimes referred to as a consolidated entry) represents.

Transaction Details is a significant nested element which represents information on the underlying transaction.

Statement > Entry > Entry Details >

Batch >

Transaction Details >



camt.053 Bank to Customer Account Statement – Transaction Details

When the Bank to Customer Statement message optional **Entry Details** is utilized the nested **Transaction Details** element is mandatory.

Transaction Details has a variety of nested elements closely associated with **Entry** level elements. The **References** element however is nested to include a variety of references related to the entry including for example the **UETR**

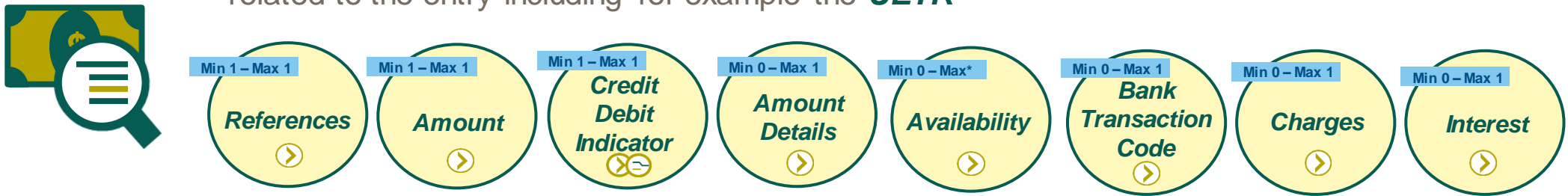

Additionally, **Transaction Details** also has a variety of elements capturing details from the underlying transaction, which amongst other business transactions includes payment transaction data. For example, **Remittance Information** and **Related Parties**

 Amount element within CBPR+ allows up to 18 digits unlike the payment messages. It allows entries reported for non CBPR+ transactions to be reported.

Statement > Entry > Entry Details > Transaction Details >

camt.053 Bank to Customer Account Statement – Related Parties & Related Agents

Min 0 – Max 1

Min 0 – Max 1

The Bank to Customer Statement message **Related Parties** and **Related Agents** represents a set of optional nested elements related to the underlying transaction. Where the **Entry Details** (the set of elements **Related Parties/Agents** belongs to) relate to a Payment, Clearing and Settlement (pacs) message, parties in the pacs messages can be transferred into the Cash Management (camt) message.



These **Related Parties** include : These **Related Agents** include :

- *Instructing Party*
 - *Debtor*
 - *Debtor Account*
 - *Ultimate Debtor*
 - *Creditor*
 - *Creditor Account*
 - *Ultimate Creditor*
- *Instructing Agent*
 - *Instructed Agent*
 - *Debtor Agent*
 - *Creditor Agent*
 - *Intermediary Agent 1*
 - *Intermediary Agent 2*
 - *Intermediary Agent 3*



Trading Party is also present in the **Related Parties** elements, and the following are present in the **Related Agents** elements: **Receiving Agents, Delivering Agent, Issuing Agent and Settlement Place**. Although these elements are not directly associated with a payment, as a Customer receiving a Statement related to other Business Domains e.g. a Security Settlement, it could be conceivable that these optional CBPR+ element may be populated



Statement > Entry > Entry Details > Transaction Details >

Related Parties >

Related Agents >

camt.053 Bank to Customer Account Statement – other underlying data

The Bank to Customer Statement message **Entry Details** have a number of additional elements beyond **Related Parties** and **Related Agents** to capture information from the underlying payment.

These are:

- *Local Instrument*
- *Purpose*
- *Related Remittance Information*
- *Remittance Information*
- *Related Dates* such as the *Interbank Settlement Date*
- *Tax*

For *Payment Return* (pacs.004) it is also possible to capture **Return Information** which includes:

- The *Original Bank Transaction Code* of the original Entry
- The *Originator* of the return from the pacs.004
- And the *Reason* code.

Remittance Information as an end-to-end element should be passed unaltered from Payment Initiation (pain) into the Payment, Clearing and Settlement (pacs) message and onto the Bank to Customer Account Statement (camt) The *Remittance Information* element is common to these message sets.



camt.053 Bank to Customer Account Statement – other underlying data (continued)

It should also be mentioned that the Bank to Customer Statement message **Entry Details** have a number of additional elements which capture information from transactions in other business domains beyond payments, as well as have an element to capture **Additional Transaction Information**.



These are:

- *Related Quantity*
- *Financial Instrument Identification*
- *Corporate Action*
- *Safekeeping Account*
- *Cash Deposit*
- *Card Transactions*

Index of camt.053 Use Cases

Use case should be considered as a principal example whereby use case may be cross referenced

Bank to Customer Statements

Use Case c.53.1.a – Bank to Customer Statement produced by the Creditor Agent

Use Case c.53.1.b – Bank to Customer Statement produced by the Debtor Agent

Use Case c.53.1.c – Bank to Customer Statement produced by an intermediary Agent

Copy of Bank to Customer Statements

Use Case c.53.2 – Bank to Customer Statement sent as an additionally copy to an authorised party

Resent Bank to Customer Statements

Use Case c.53.3 – Bank to Customer Statement resent a previously sent statement/s to the Account Owner

Use Case c.53.4 – Bank to Customer Statement resent a previously sent copy statement/s to an authorised party

Forwarding of Bank to Customer Statements

Use Case c.53.5 – Bank to Customer Statement sent to an authorised party who forward/provides on to the Account Owner (commonly referred to as an account concentrating model)



Use Case camt.060 for requesting a Bank to Customer statement



Use Case for copy or duplicate reports refer to camt.053 use cases

Bank to Customer Statement produced by the Creditor Agent

Use Case c.53.1.a

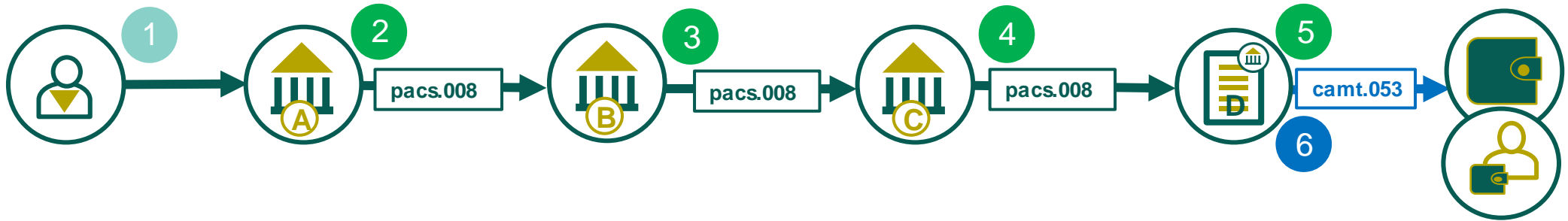

1 Debtor initiates a payment instruction to the Debtor Agent

2 Debtor Agent (A) initiates a serial payment towards the Creditor Agent (D) using Agents B & C as intermediaries

3 Agent B processes the payment on Agent C

4 Agent C processes the payment on Agent D

5 Creditor Agent credits the account of the Creditor

6 Creditor Agent as the Account Servicer produces and sends a statement to either the Account Owner, or an authorised third party.

Bank to Customer Statement produced by the Debtor Agent

Use Case c.53.1.b

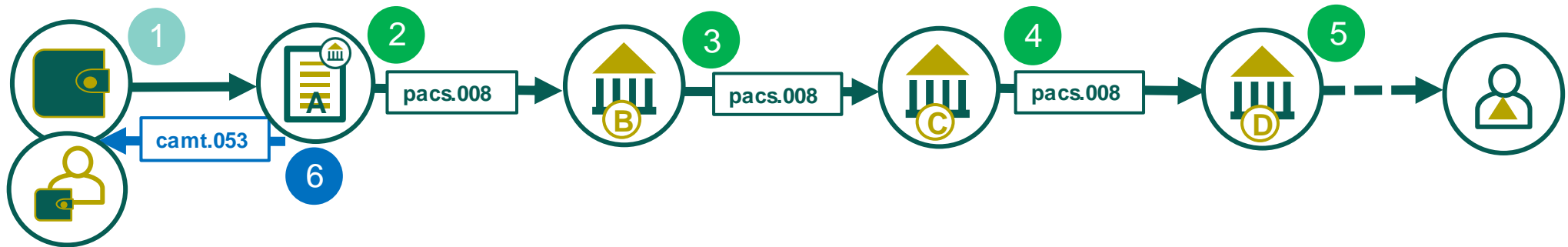

1 Debtor initiates a payment instruction to the Debtor Agent

2 Debtor Agent (A) initiates a serial payment towards the Creditor Agent (D) using Agents B & C as intermediaries

3 Agent B processes the payment on Agent C

4 Agent C processes the payment on Agent D

5 Creditor Agent credits the account of the Creditor

6 Debtor Agent as the Account Servicer produces and sends a statement to either the Account Owner, or an authorised third party.

Bank to Customer Statement produced by an intermediary Agent

Use Case c.53.1.c

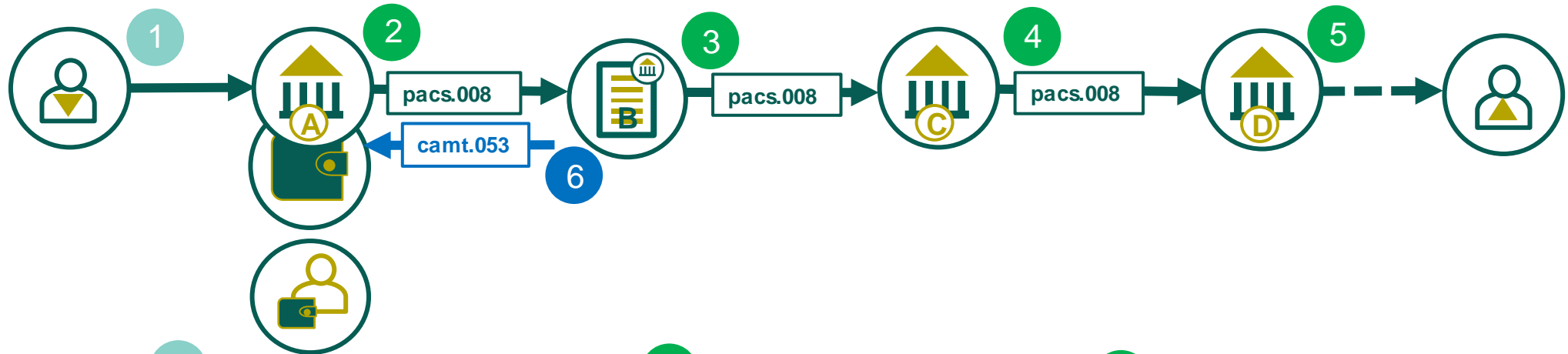

1 Debtor initiates a payment instruction to the Debtor Agent

2 Debtor Agent (A) initiates a serial payment towards the Creditor Agent (D) using Agents B & C as intermediaries

3 Agent B processes the payment on Agent C

4 Agent C processes the payment on Agent D

5 Creditor Agent credits the account of the Creditor

6 Intermediary Agent as the Account Servicer produces and sends a statement to either the Account Owner, or an authorised third party.

Bank to Customer Statement sent as an additionally copy to an authorised party

Use Case c.53.2

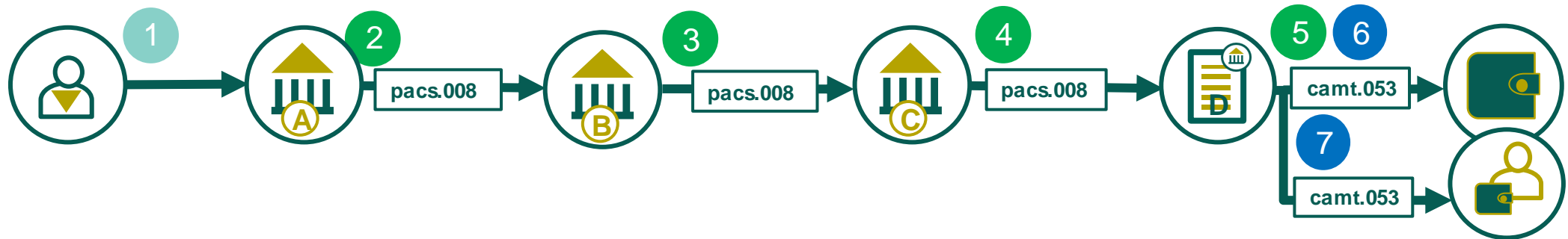

1 Debtor initiates a payment instruction to the Debtor Agent

2 Debtor Agent (A) initiates a serial payment towards the Creditor Agent (D) using Agents B & C as intermediaries

3 Agent B processes the payment on Agent C

4 Agent C processes the payment on Agent D

5 Creditor Agent credits the account of the Creditor

6 Creditor Agent as the Account Servicer produces and sends a statement to the Account Owner.

7 Creditor Agent as the Account Servicer sends an additional copy of the statement to an authorised third part. COPY is populated in the Copy Duplicate Indicator element within the Bank to Customer Statement message (camt.053)

Bank to Customer Statement resent a previously sent statement/s to the Account Owner

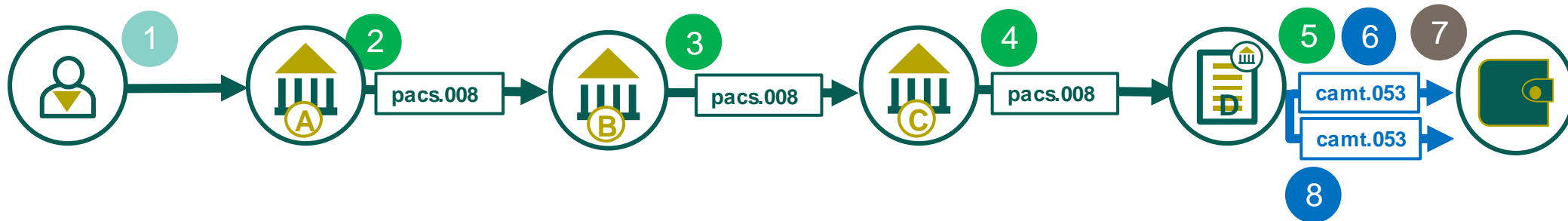

1 Debtor initiates a payment instruction to the Debtor Agent

2 Debtor Agent (A) initiates a serial payment towards the Creditor Agent (D) using Agents B & C as intermediaries

3 Agent B processes the payment on Agent C

4 Agent C processes the payment on Agent D

5 Creditor Agent credits the account of the Creditor

6 Creditor Agent as the Account Servicer produces and sends a statement to the Account Owner.

7 Creditor as the Account Owner requests a previously sent statement message/s to be resent to them.

8 Creditor Agent as the Account Servicer re-sends a duplicate statement to the account owner. DUPL is populated in the Copy Duplicate Indicator element within the Bank to Customer Statement message (camt.053)

Bank to Customer Statement resent a previously sent copy statement/s to an authorised party

Use Case c.53.4

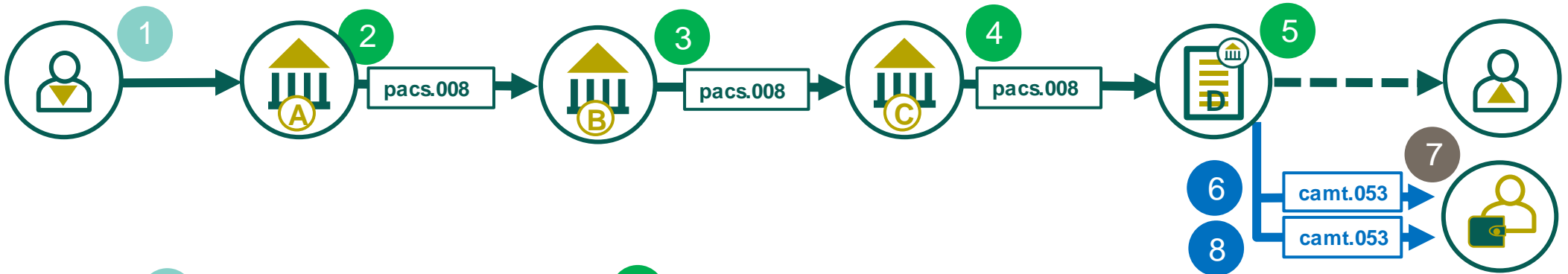

1 Debtor initiates a payment instruction to the Debtor Agent

2 Debtor Agent (A) initiates a serial payment towards the Creditor Agent (D) using Agents B & C as intermediaries

3 Agent B processes the payment on Agent C

4 Agent C processes the payment on Agent D

5 Creditor Agent credits the account of the Creditor

6 Creditor Agent as the Account Servicer produces and sends a statement to an authorised third part.

7 Authorised third party requests a previously sent statement message/s to be resent to them.

8 Creditor Agent as the Account Servicer re-sends a duplicate statement to the authorised third party. CODU is populated in the Copy Duplicate Indicator element within the Bank to Customer Statement message (camt.053)

Bank to Customer Statement sent to an authorised party who forward/provides on to the Account Owner (commonly referred to as an account concentrating model)

Use Case c.53.5

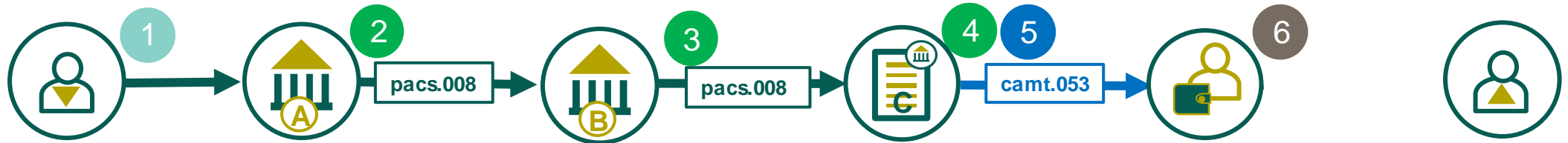

1 Debtor initiates a payment instruction to the Debtor Agent

2 Debtor Agent (A) initiates a serial payment towards the Creditor Agent (C) using Agents as an intermediary

3 Agent B processes the payment on Agent C

4 Creditor Agent credits the account of the Creditor

5 Creditor Agent as the Account Servicer produces and sends a statement to an authorised third part.

6 Authorised third part provides statement information to the Account Owner. Which could be the forwarded Camt.053 statement or the details via an alternative channel (e.g. host to host file, GUI etc.)

camt.054

Bank to Customer Debit Credit Notification



camt.054 Bank to Customer Debit Credit Notification

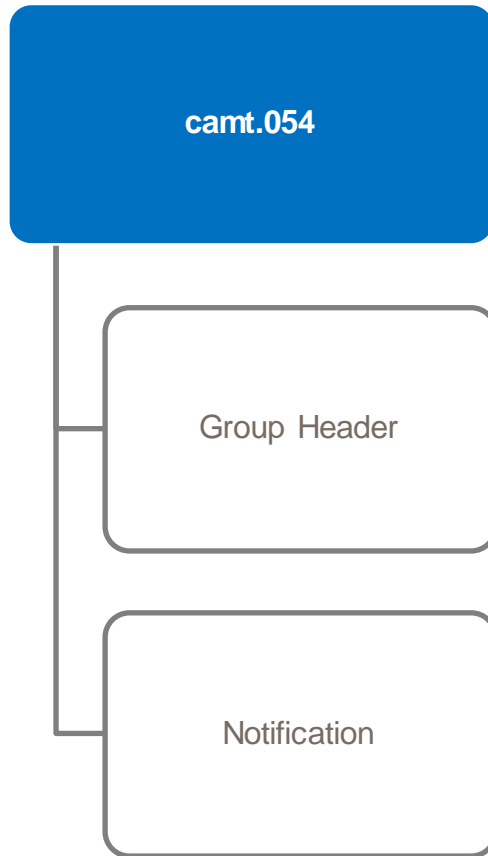

The *Bank To Customer Debit Credit Notification* message is sent by the account servicer to an account owner or to a party authorised by the account owner to receive the message. It can be used to inform the account owner, or authorised party, of single or multiple debit and/or credit entries reported to the account



The Bank to Customer Debit Credit Notification allows multiple Notifications per InterAct message (100,000 bytes) It is however recommended to report single notifications per transaction. This message must be bilaterally agreed between the Account Servicing Institution and the Account owner, and is establish by an RMA business profile.

High Level Bank to Customer Debit Credit Notification (camt.054)

camt.054

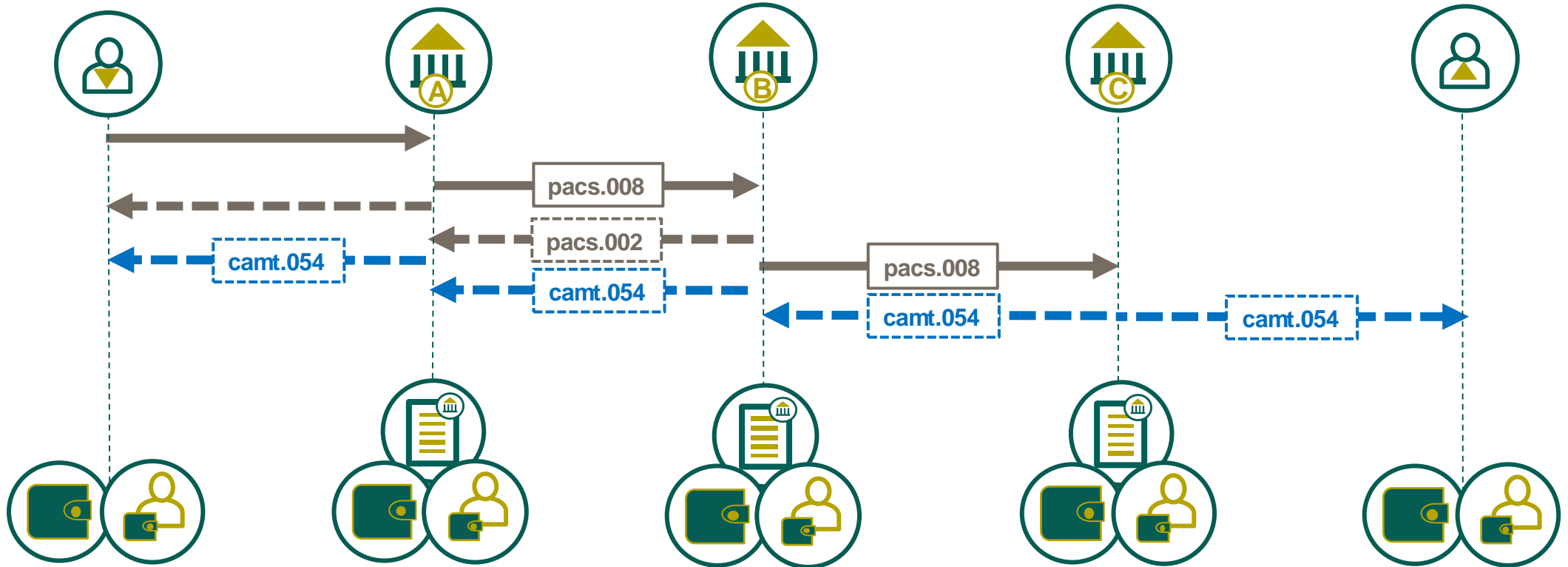

Role of the Agent/s, Debtor and Creditor in the payment changes by description in the Bank to Customer Debit Credit Notification message to Account Servicer and Account Owner. Whereby the notification is sent by the Account Servicer to the Account Owner and or authorised party.



High Level Bank to Customer Debit/Credit Notification (camt.054)

The *Customer Debit Credit Notification* are optionally provided between the account servicing institution and the account owner, or authorised (third) party.

These messages:

- are used to inform on debit and/or credit entries reported to an account.
- and may also be complemented by:
 - a *Status Information* message:
 - pacs.002 in Payment Clearing and Settlement, or pain.002 in Payment Initiation.
 - or by a bank statement such as the camt.053 *Bank to Customer Statement Report*

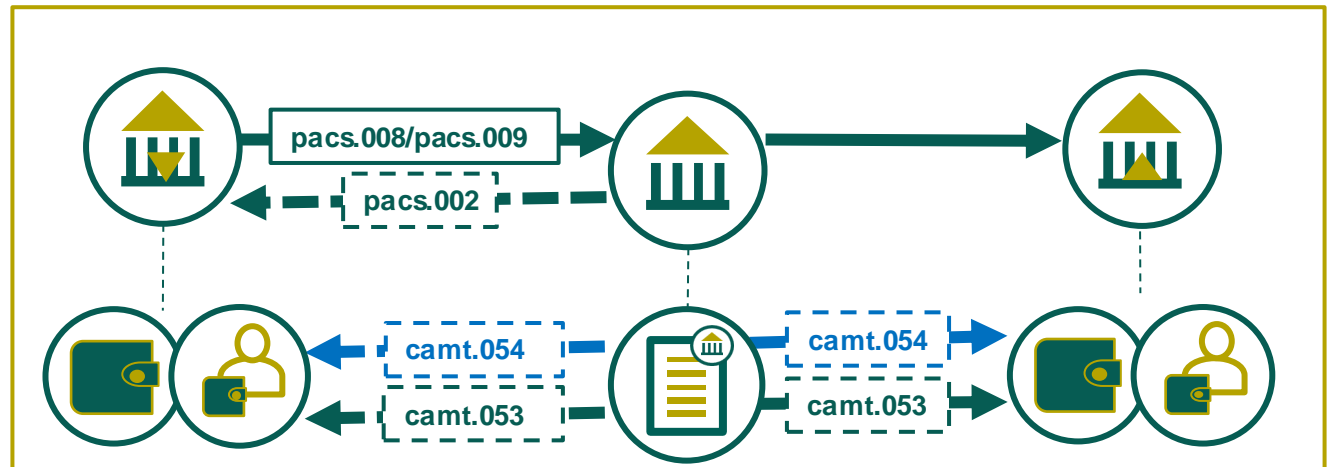
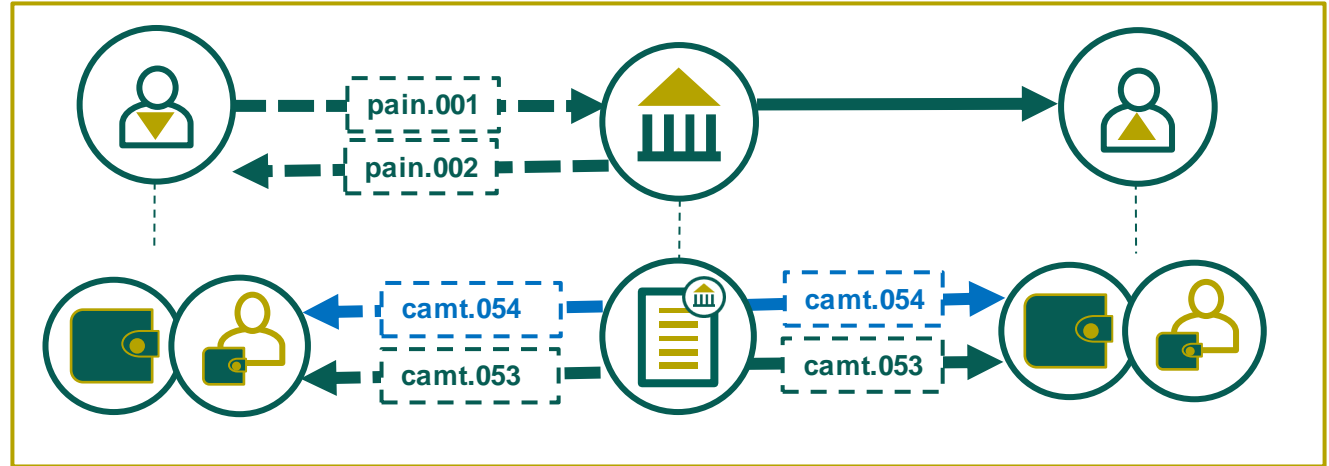

Group Header



camt.054 Bank to Customer Account Debit Credit Notification - Message Identification



Each ISO 20022 cash management reporting message has a *Message Identification* element, located in the Group Header. This **35 character** identifier is a point-to-point reference used to unambiguously identify the message.

For Cash Management (camt) messages the *Message Identification* has no exact equivalent in the legacy MT Customer Statement message. However the *Transaction Reference Number* (Field 20) could be considered a similar comparison.

Group Header ➤ Message Identification

camt.054 Bank to Customer Debit Credit Notification – Creation DateTime

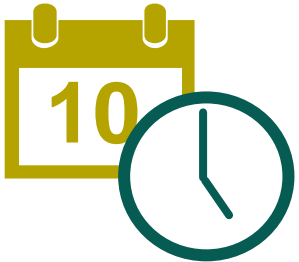

CBPR+ usage guidelines mandate the time zone that the time represents as an offset against Universal Time Coordinated (UTC):

Local time with UTC offset `YYYY-MM-DDThh:mm:ss.sss+/-hh:mm`

- For example: `2002-10-10T12:00:00-05:00` (noon/midday on 10 October 2002, Central Daylight Savings Time as well as Eastern Standard Time in the U.S.)



All CBPR+ time elements need offset against UTC. Milliseconds are optional.

Group Header ▶ Creation Date Time

camt.054 Bank to Customer Debit Credit Notification – Message Recipient

Min 0 – Max 1

The Bank to Customer Debit Credit Notification **Message Recipient** nested element provides details of the party authorised by the *Account Owner* to receive the Debit Credit Notification.

This element **should only** be used to identify the *Message Recipient* when different from the account owner, which is implied by the usage of **COPY** in the *Copy Duplicate Indicator* within the nested Notification element.



Where **Message Recipient** is used the nested:

- **Name** Min 0 – Max 1
- **Postal Address** Min 0 – Max 1
- **Identification** Min 0 – Max 1
- **Contact Details** Min 0 – Max 1

May be used to capture information related to this party.

Group Header ▶ Message Recipient ▼

Name

▶ Postal Address

⊗ Identification

▶ Contact Details

636



camt.054 Bank to Customer Debit Credit Notification – Original Business Query

The Bank to Customer Debit Credit Notification **Original Business Query** ^{Min 0 – Max 1} element identifies a query to generate a report, for example a camt.060 Account Reporting Request.



Where **Original Business Query** is used the original **Message Identification** ^{Min 1 – Max 1} (i.e. the message identification of the camt.060 message) is required.
Original **Message Name identification** and Original **Creation Date Time** ^{Min 0 – Max 1} may also be provided. ^{Min 0 – Max 1}

Group Header ▶ Original Business Query ▼

Message Identification

Message Name Identification

Creation Date Time 637

camt.054 Bank to Customer Debit Credit Notification – Additional Information

Min 0 – Max 1

The Bank to Customer Debit Credit Notification **Additional Information** element represents further details related to the account statement.

The camt.054 may be used to indicate a particular type of notification, recognizing all transactions within the notification belong to the type indicated below:



/LBOX/ Lock Box

/BULK/ Bulk reporting (batch transaction with underlying transaction)

/RTRN/ Return report

/CRED/ Notification with Credit entries ONLY



Additional Information is a textual element restricted in CBPR+ to 500 characters.

Group Header  Additional Information

Notification



camt.054 Bank to Customer Debit Credit Notification – Notification

Min 0 – Max *

The Bank to Customer Debit Credit Notification **Notification** nested element captures debit and credit entry information for an account.



The *Notification* element has a couple of options to notify on multiple Debits and or Credits. This can be achieved at either the **Notification** element itself which could principally report on more than one account held by the account owner with the Account Servicer or can be achieved at an **Entry** level.

Notification of multiple Debits and or Credits is perhaps more associated with a timed or batch creation of the camt.054 Bank to Customer Debit Credit Notification. Whereas the more common example of a real-time notification produced at the point of an account posting would typically notify on a single *Entry*.

Notification >

camt.054 Bank to Customer Debit Credit Notification - Identification

Min 1 – Max 1

The Bank to Customer Debit Credit Notification message **Identification** provides a mandatory element to identify the notification



Unique reference assigned by the account servicer to unambiguously identify the account statement. Directly comparable with the *Transaction Reference Number* (Field 20) of the legacy MT statement message.

Statement  Identification

camt.054 Bank to Customer Debit Credit Notification – Notification Pagination

The Bank to Customer Debit Credit Notification message **Notification Pagination** element provides the page number of the notification.



Where **Notification Pagination** is used the **Page Number** and **Last Page indicator** elements are both mandatory.

For example, a *Page Number* of 2 represents the current account statement, being the second page of the and implying a previous account statement page had been sent. The *Last Page indicator* further implies whether more pages are expected



Either *Message Pagination* (Group Header) or *Notification Pagination* (Notification) may be used but not both

Notification Notification Pagination

Page Number

Last Page indicator



camt.054 Bank to Customer Debit Credit Notification - Electronic Sequence Number

Min 0 – Max 1

The Bank to Customer Debit Credit Notification message **Electronic Sequence Number** allows the *Account Servicer* to assign a number to each notification which should increment by 1 for each electronic notification report sent.



As a good practice this element allows easy recognition of the notification order, if not recognisable by other data within the notification, such as the **Notification > Identification** element.

Should this sequence number be reset by the *Account Servicer*, this should not occur more frequently than once a year. Likewise, this 18 digit counter could be incremented to its maximum value before it's reset.



The use of Electronic Sequence Number and the sequence reset logic should be bilaterally agreed between the *Account Servicer* and the *Account Owner*

Notification > Electronic Sequence Number

camt.054 Bank to Customer Debit Credit Notification - Reporting Sequence

The Bank to Customer Debit Credit Notification message **Reporting Sequence** ^{Min 0 – Max 1} specifies the choice of identification sequences. This can be used as an alternative to the **Statement Pagination** or **Electronic Sequence Number** as a way to identify the statement order, which is not confined to numeric values. 

Where used the **Reporting Sequence** mandate a choice of nested element:

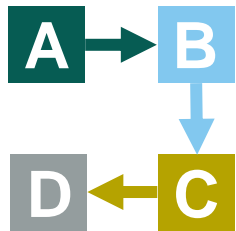

- **From Sequence** identifies the start of a sequence range. ^{Min 1 – Max 1}
- **To Sequence** identifies the end of a sequence range. ^{Min 1 – Max 1}
- **From To Sequence** identifies the start and end of a sequence range. ^{Min 1 – Max *}
- **Equal Sequence** identifies a sequence. ^{Min 1 – Max *}
- **Not Equal Sequence** identifies a sequence to be excluded. ^{Min 1 – Max *}



Although the Reporting Sequence may be provided in a camt.060 Account Reporting Request, the use of this message to request a Bank to Customer Debit Credit Notification is less compelling, whereby such notifications are typically triggered as the result of an account posting, rather than being requested.

Notification  Report Sequence 

camt.054 Bank to Customer Debit Credit Notification - Legal Sequence Number

Min 0 – Max 1

The Bank to Customer Debit Credit Notification message **Legal Sequence Number** allows the *Account Servicer* to assign a number to each notification which should increment by 1 for each notification report sent.



In the case of a real-time notification the **Legal Sequence Number** element has little value, unlike its use in a statement message.

Notification ▶ Legal Sequence Number

camt.054 Bank to Customer Debit Credit Notification - Creation Date Time

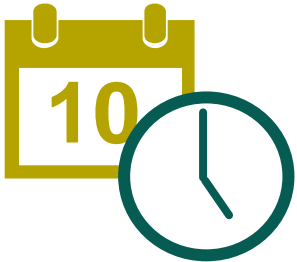

CBPR+ usage guidelines mandate the time zone that the time represents as an offset against Universal Time Coordinated (UTC):

Local time with UTC offset `YYYY-MM-DDThh:mm:ss.sss+/-hh:mm`

- For example: `2002-10-10T12:00:00-05:00` (noon/midday on 10 October 2002, Central Daylight Savings Time as well as Eastern Standard Time in the U.S.)



All CBPR+ time elements need offset against UTC. Milliseconds are optional.

camt.054 Bank to Customer Debit Credit Notification – From To Date

Min 0 – Max 1

The Bank to Customer Debit Credit Notification message **From to Date** allows the *Account Servicer* to specify the start date time and end date time applicable to the notification.

Where **From to Date** is used the **From Date Time** and **To Date Time** become mandatory elements.

Min 1 – Max 1

Min 1 – Max 1

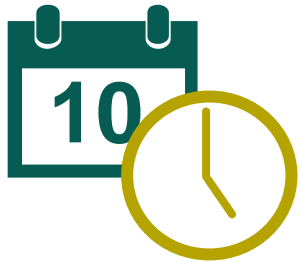

CBPR+ usage guidelines mandate the time zone that the time represents as an offset against Universal Time Coordinated (UTC):

Local time with UTC offset YYYY-MM-DDThh:mm:ss.sss+/-hh:mm

- For example: 2002-10-10T12:00:00-05:00 (noon/midday on 10 October 2002, Central Daylight Savings Time as well as Eastern Standard Time in the U.S.)



All CBPR+ time elements need offset against UTC. Milliseconds are optional.

Notification 

From to Date

To Date Time



camt.054 Bank to Customer Debit Credit Notification – Copy Duplicate Indicator

Min 0 – Max 1

The Bank to Customer Debit Credit Notification message **Copy Duplicate Indicator** is used as a choice to identify additional notification from the original sent to the Account Owner.

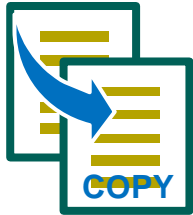

COPY is used when a copy of the notification is sent to an Authorised Third Party, such as a company head office, parent entity, or an institution providing additional service such as liquidity sweeping or statement consolidation.

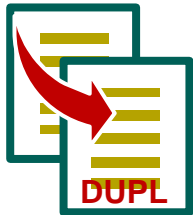

DUPL is used when a duplicate of the notification is sent to the Account Owner, this resubmission may have been requested using the camt.060 or an alternative channel such as via internet banking or customer service request.



CODU is used when a duplicate of a notification copy is sent to an Authorised Third Party, this resubmission may have been requested using the camt.060 or an alternative channel such as via internet banking or customer service request. It may also be requested by the Account Owner on behalf of the Authorised Third Party, depending on the arrangement in place with the Account Servicer.

Notification > Copy Duplicate Indicator >

camt.054 Bank to Customer Debit Credit Notification – Reporting Source

Min 0 – Max 1

The Bank to Customer Debit Credit Notification message **Reporting Source** allows the *Account Servicer* to define the source of the notification, typically associated with an application.

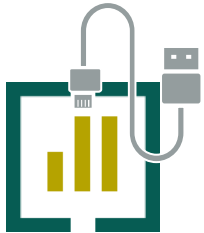

Reporting Source utilizes the external Reporting Source code list. For example, **ACCT** represents a notification based on accounting data, whereas **DEPT** represents a cash or deposit system.

Where the source of the notification is functionally required by the consumer of the notification i.e., the *Account Owner* or *authorised Third Party*, the codes used should be bilaterally agreed.

Notification > Reporting Source

camt.054 Bank to Customer Debit Credit Notification - Account

The Bank to Customer Debit Credit Notification message **Account** provides nested elements to identify the account for which debit and credit entries have been made. The following two mandatory elements are nested beneath *Account*.

Min 1 – Max 1

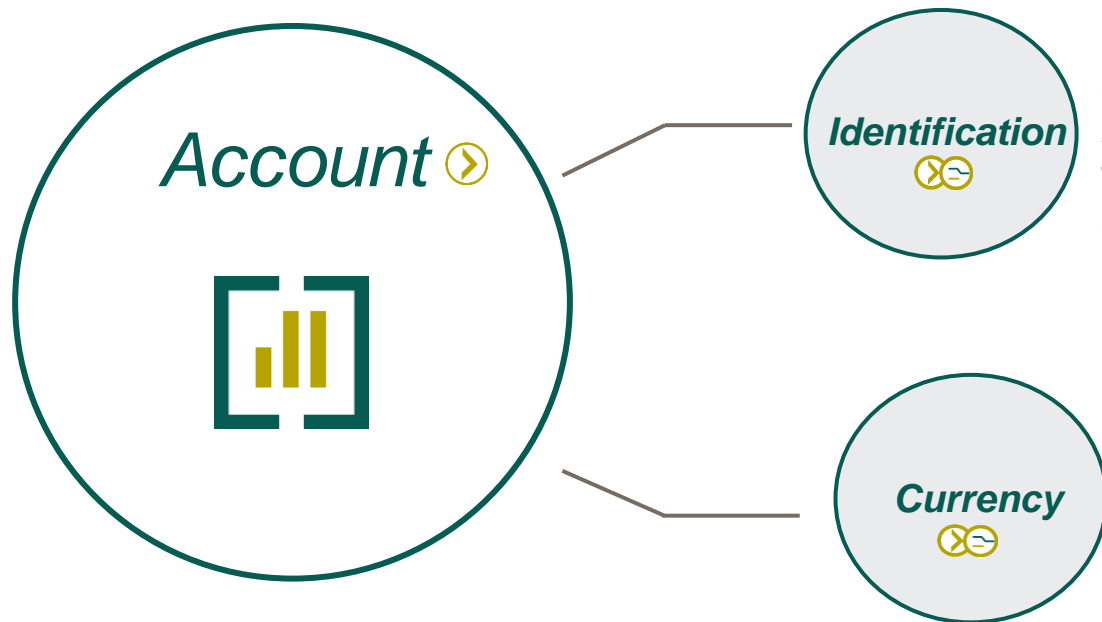

Min 1 – Max 1

a unique **Identification** for the account, between the Account Servicer and Account Owner. The element is further nested by choice of **IBAN** or **Other** to capture the account.

Min 1 – Max 1

The **Currency** for which the account is held. This is identified using the three characters ISO currency code.

Notification > Account >

camt.054 Bank to Customer Debit Credit Notification - Account (continued)

The Bank to Customer Debit Credit Notification message mandatory **Account** ^{Min 1 – Max 1} also provides a number of optional nested element to identify the account for which debit and credit entries have been made.

Min 0 – Max 1

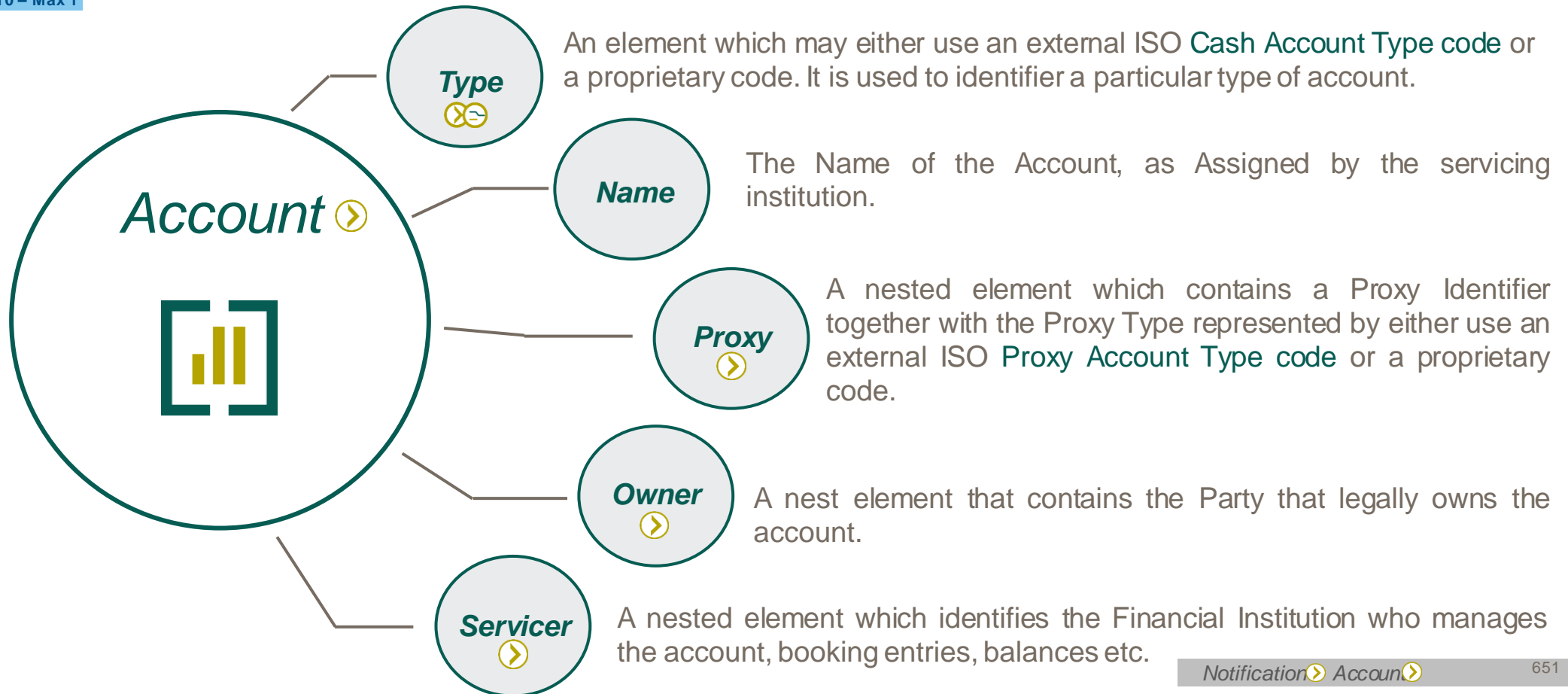

camt.054 Bank to Customer Debit Credit Notification – Related Account

Min 0 – Max 1

The Bank to Customer Debit Credit Notification message **Related Account** allows the identification of a related parent account for the account notification. For example sweeping, pooling or virtual account for which the notification is produced can identify the parent account they hierarchically relate to.

Min 1 – Max 1

Min 1 – Max 1

When **Related Account** is utilized, like **Account**, the **Identification** and **Currency** element become mandatory.

Additionally, the nested **Type** element, **Name** and nested **Proxy** element are optionally available.

Min 0 – Max 1

Min 0 – Max 1

Min 0 – Max 1



Related Account uses a variety of common elements described in more detail within the *Account* section.

Notification > Related Account

Identification

Type

Currency

Name

652

Proxy

camt.054 Bank to Customer Debit Credit Notification – Interest

Min 0 – Max *

The Bank to Customer Debit Credit Notification message **Interest** provides interest information that applies to the account. Inclusion of such interest information is perhaps more common to the camt.053 Statement than a Debit Credit Notification.

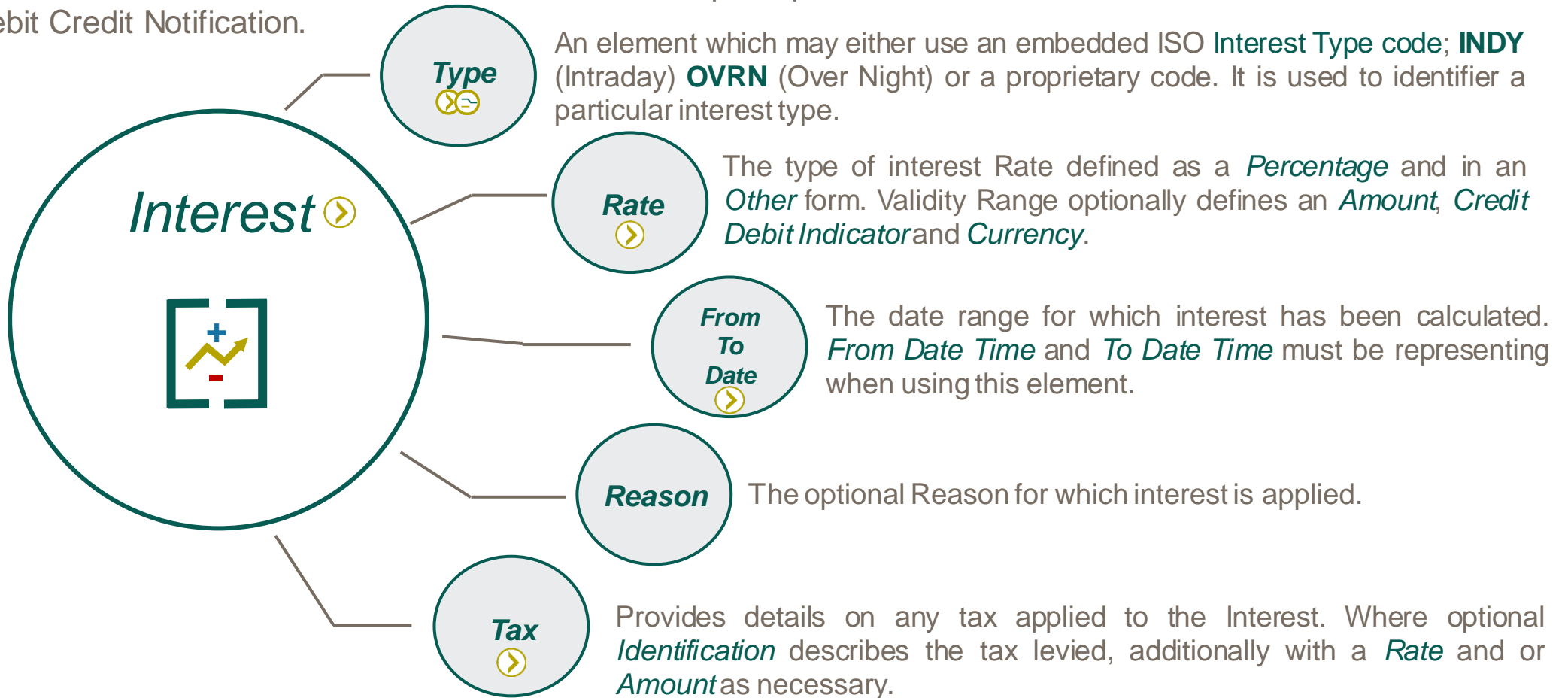

camt.054 Bank to Customer Debit Credit Notification – Transaction Summary

Min 0 – Max 1

The Bank to Customer Debit Credit Notification message optional **Transaction Summary** provides a set of nested element to summarize entry information. More commonly the Bank to Customer Debit Credit Notification is reporting a single Debit or Credit transaction, where understandably the use of Transaction Summary provides little value.

Each of the following element allow an optional total of entries either as a **Number of Entries** and or as a **Sum**.



- **Total Entries**
- **Total Credit Entries**
- **Total Debit Entries**
- **Total Entries Per Bank Transaction Code**

Min 0 – Max *

In addition to the **Number of Entries** and **Sum**, the **Total Entries Per Bank Transaction Code** requires the **Bank Transaction Code** element and optionally allows a variety of other optional elements.

Min 1 – Max 1



The **Total Entries Per Bank Transaction Code** element is unlimited (Max *) whereby more that one **Bank Transaction Code** may be summarised.

Notification > Transaction Summary >

Total Entries >

Total Credit Entries >

Total Debit Entries >

Total Entries per Bank Transaction Code >

camt.054 Bank to Customer Debit Credit Notification – Entry

The Bank to Customer Debit Credit Notification message optional **Entry** provides a significant variety of nested elements to represent the details associated with each Debit or Credit **Entry**.



Unlike the legacy MT 900 MT 910 confirmation messages, the camt.054 has a number of dedicated elements to capture a variety of entry level data. It also has an number of enhancements on the legacy MT confirmation message where parties in the payment and customer remittance information, as examples, can provided to the *Account Owner*.

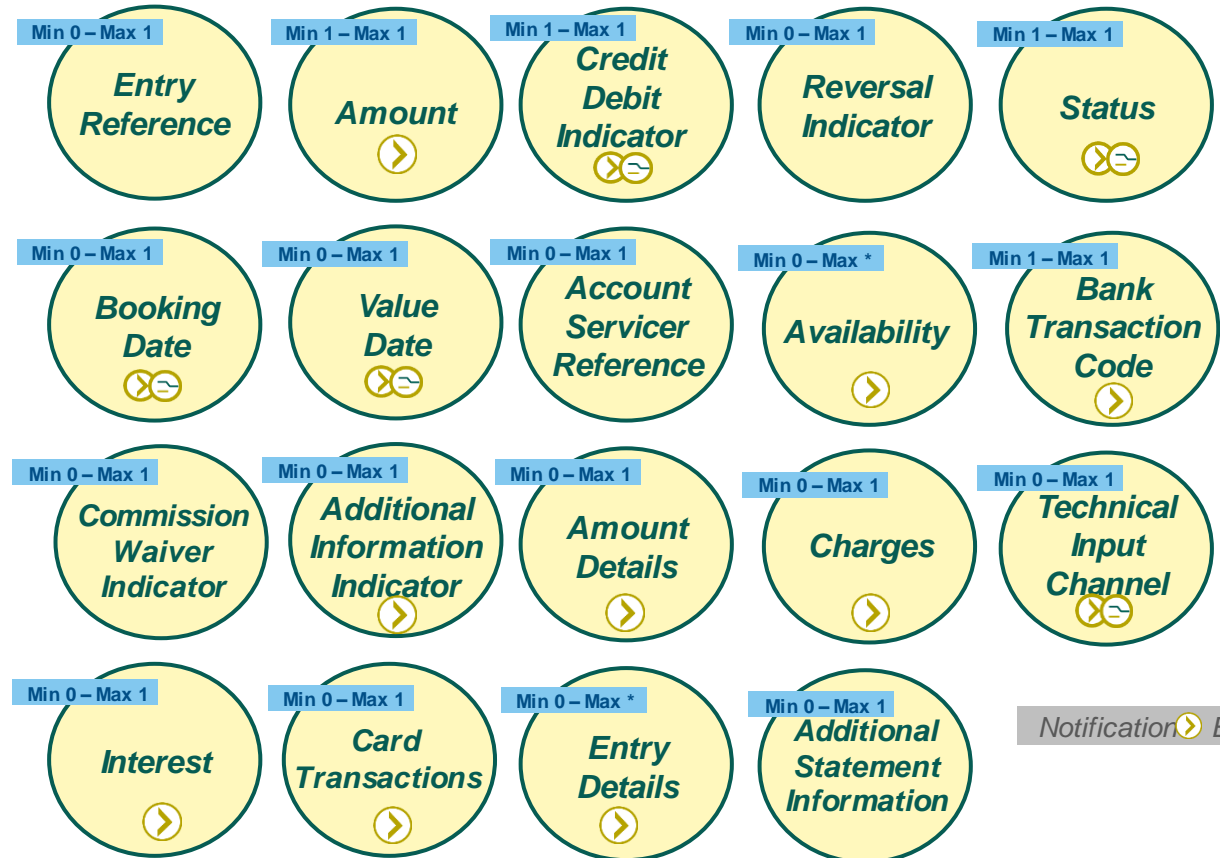

camt.054 Bank to Customer Debit Credit Notification – Entry (continued)

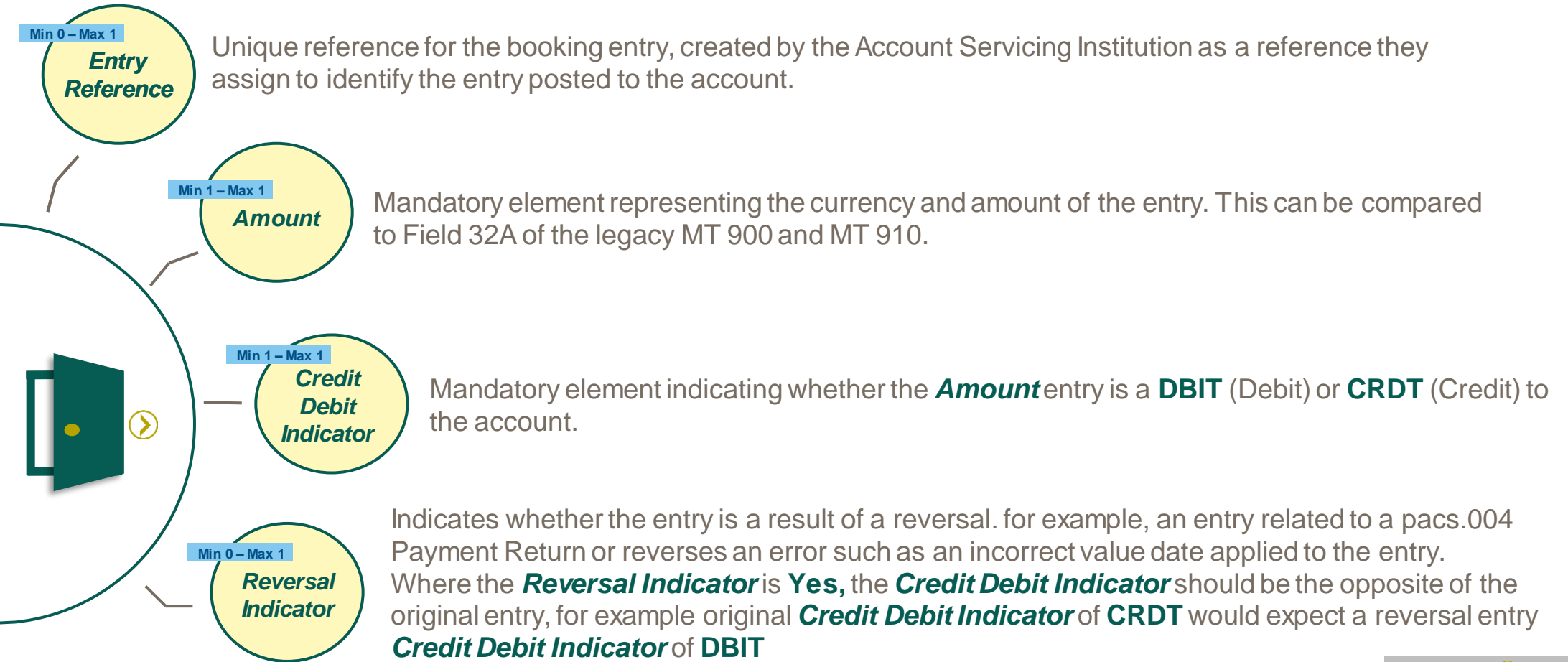

camt.054 Bank to Customer Debit Credit Notification – Entry (continued)

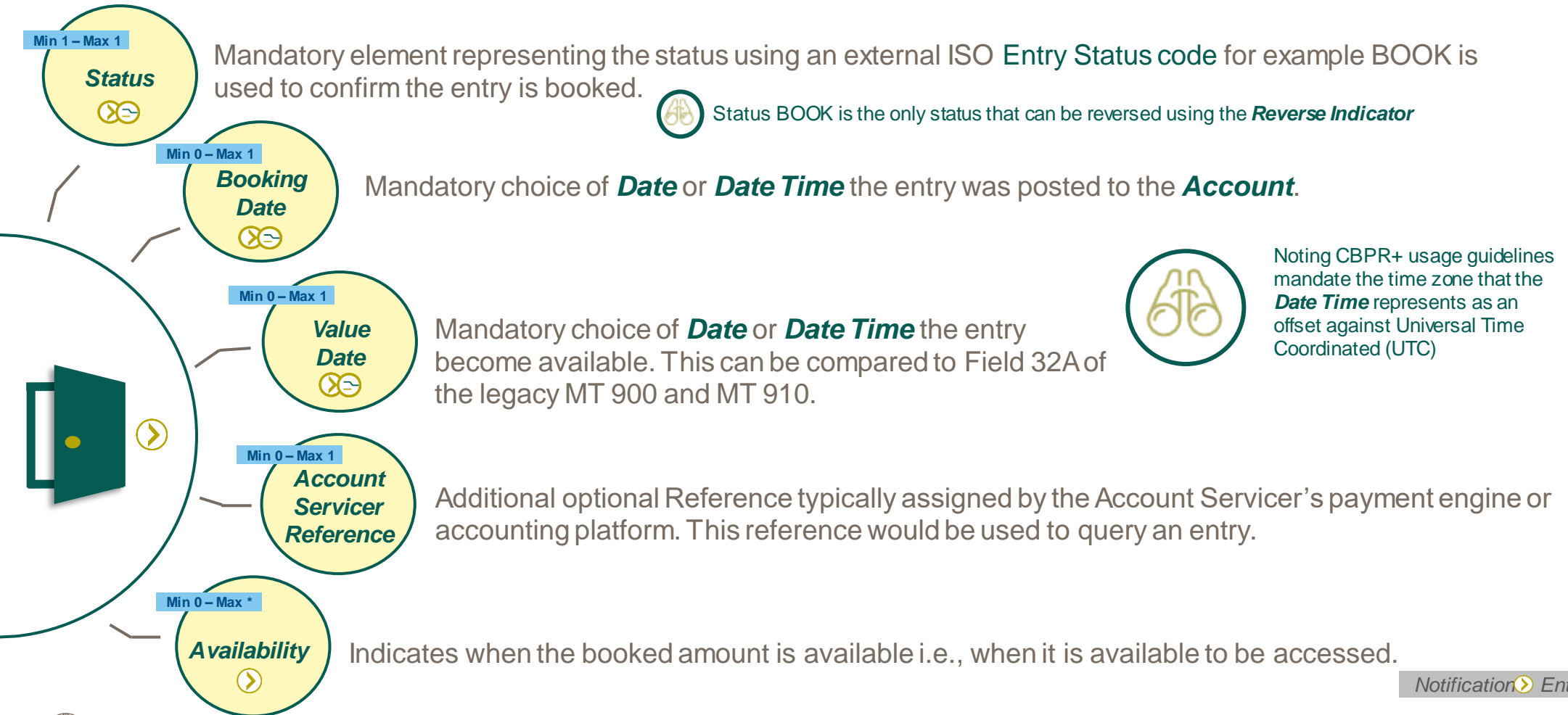

camt.054 Bank to Customer Debit Credit Notification – Entry (continued)

Min 1 – Max 1

Bank Transaction Code



The **Bank Transaction Code** is designed to deliver a harmonized set of codes, which should be applied in bank-to-customer cash account reporting information. The bank transaction code information allows the **account servicer** to correctly report a transaction, which in its turn will help **account owners** to perform their cash management and reconciliation operations.

The structure of the Bank Transaction Code has three levels:

Domain: Highest definition level to identify the sub-ledger. The domain defines the business area of the underlying transaction e.g., payment, securities etc.)

Family: Medium definition level e.g. type of payment; credit transfer, direct debit etc.

Sub-family: Lowest definition level e.g. type of cheques; draft etc.

Bank Transaction Codes are an external code set defined in the *Bank Transaction Code combinations* external code sets.

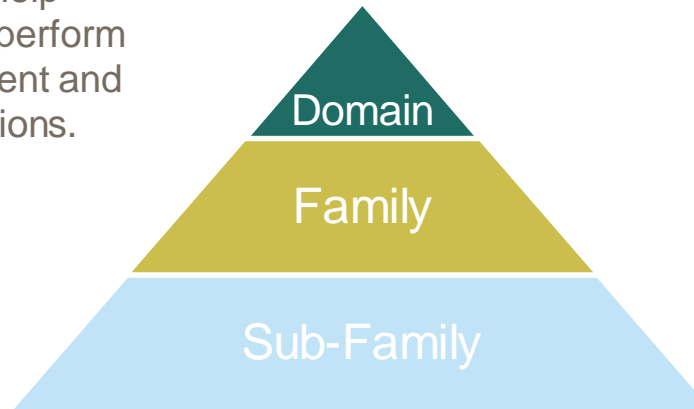

Notification Entry Bank Transaction Code

Domain

Family 658

Sub Family



camt.054 Bank to Customer Debit Credit Notification – Bank Transaction Code descriptions

Min 1 – Max 1

The description of **Bank Transaction Codes** are available to download from the ISO20022.org external code list page. These include the descriptions for Payments Domain Families and sub-families for both Received and Issued Credit Transfers.

https://www.iso20022.org/external_code_list.page

Payments Domain Families		
1. Received Credit Transfers	Receivable Credit Transfers are instructions to receive an amount of money from a del the account owner. The receivable credit transfers are related to transactions received t account owner.	
2. Issued Credit Transfers	Payable Credit Transfers are instructions to transfer an amount of money by the accou to a creditor. The payable credit transfers are related to instructions sent by the accoun	
3. Received Cash Concentration	Transaction is related to incoming cash movements that are related to cash managemer activities initiated by the owner of the sending account to optimise the return on the av funds.	
4. Issued Cash Concentration	Transaction is related to outgoing cash movements that are related to cash managemen activities initiated by the owner of the account to optimise the return on the available f	
5. Received Direct Debits	The Received Direct Debit transactions are related to instructions received by the acco to debit the account.	
6. Issued Direct Debits	The Issued Direct Debit transactions are related to instructions sent by the account owi collect an amount o	
7. Received Cheques	Transaction is relat from the cheque dr:	
8. Issued Cheques	Transaction is relat	
Sub-Families for both Received and Issued Credit Transfers		
	Sub-Family	Definition
	Internal Book Transfer	Transaction is a transfer between –two different accounts within the same bank.
	Standing Order	Transaction is a standing order. A standing order is an instruction given by a party having authority on the debtor’s account to debit, i.e. either debit account owner or originating p; account servicer, to process credit transfers at specified intervals during an implicit or exp period of time. It is given once, and is valid for an open or closed period of time.
	Cross-Border Standing Order	Transaction is a cross-border standing order
	SEPA Credit Transfer	Transaction is a SEPA credit transfer
	Domestic Credit Transfer	Transaction is a in-country domestic currency credit transfer
	Cross-Border Credit Transfer	Transaction is a cross-border credit transfer
	Credit Transfer with agreed Commercial Information	Transaction is a credit transfer including commercial information, i.e. additional informat agreed between the sender and the receiver.
	Financial Institution Credit Transfer	Transaction is a financial institution credit transfer, i.e. the debtor and creditor are financi institutions.
	Priority Credit Transfer	Transaction is a credit transfer defined with higher priority, eg a PRIEURO credit transfe:
	Payroll/Salary Payment	Transaction is related to the payment of a payroll salary
	Cross-border	Transaction is related to the payment of a cross-border payroll salary



camt.054 Bank to Customer Debit Credit Notification – Bank Transaction Code combinations

Bank Transaction Code - all permitted combinations of the BTC code sets							
All codes in light grey are defined as the generic codes available for all Domains and Families							
Domain	Family	SubFamily	Domain Code	Family Code	SubFamily Code	Status	Status Date
Payments	Issued Credit Transfers	Cross-Border Credit Transfer	PMNT	ICDT	XBCT	New	27/4/2009
Payments	Received Credit Transfers	Cross-Border Credit Transfer	PMNT	RCDT	XBCT	New	27/4/2009

Bank Transaction Codes are an external code set defined in the *Bank Transaction Code combinations* external code sets.

As an example a debit notification which relates to a cross-border payment initiated from an account would be represented by:

Domain	Family	Sub-Family
PMNT (Payment)	ICDT (Issued Credit Transfer)	XBCT (Cross-Border Credit Transfer)



camt.054 Bank to Customer Debit Credit Notification – Entry (continued)

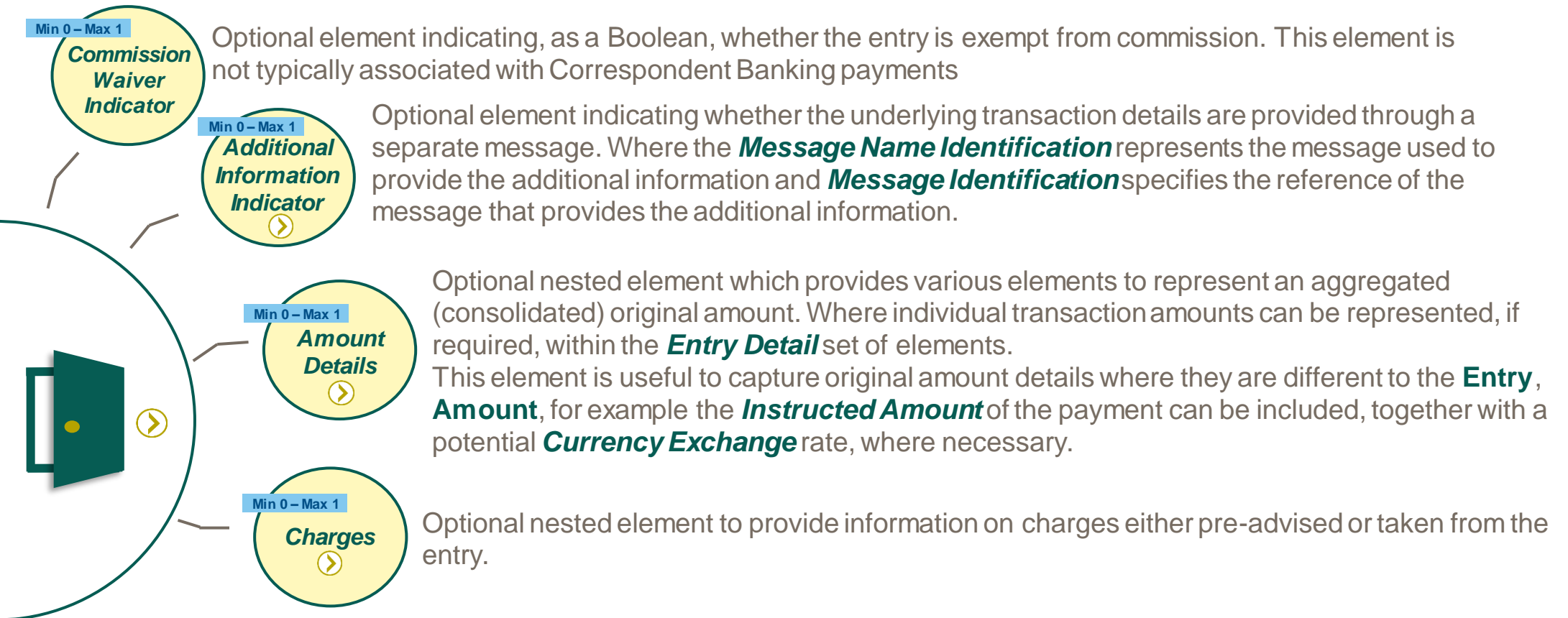

Notification > Entry >

camt.054 Bank to Customer Debit Credit Notification – Entry (continued)

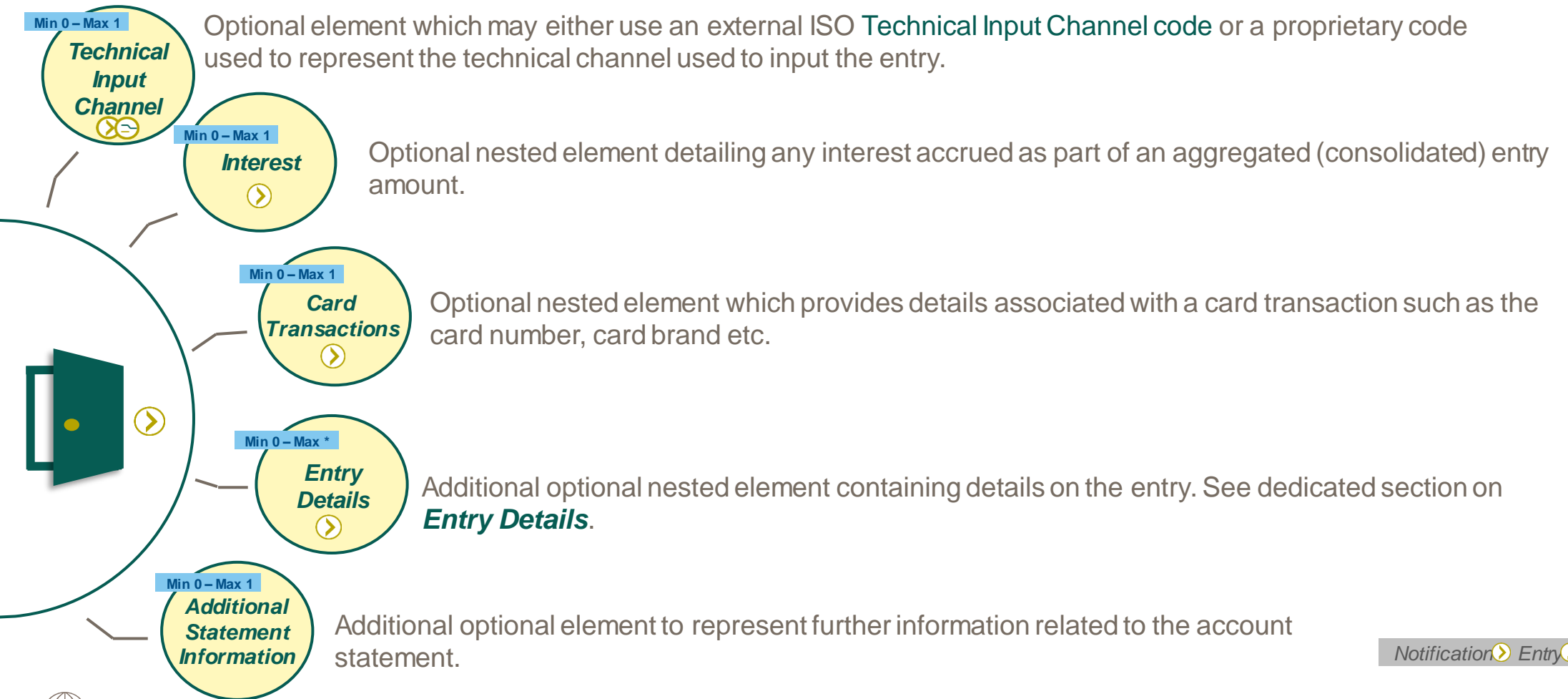

Notification ▶ Entry ▶



camt.054 Bank to Customer Debit Credit Notification – Entry Details

The Bank to Customer Debit Credit Notification message optional **Entry Details** provides a variety of nested elements to represent the details associated with each **Entry**. Min 0 – Max *



Batch provides details on batched transactions such as the total **Number of Transactions** the batched entry (sometimes referred to as a consolidated entry) represents.

Transaction Details is a significant nested element which represents information on the underlying transaction.



Notification > Entry > Entry Details ✓

Batch >

Transaction Details >

camt.054 Bank to Customer Debit Credit Notification – Transaction Details

When the Bank to Customer Debit Credit Notification message optional **Entry Details** is utilized the nested **Transaction Details** element is mandatory.

Min 1 – Max 1

Transaction Details has a variety of nested elements closely associated with **Entry** level elements. The **References** element however is nested to include a variety of references related to the entry including for example the **UETR**

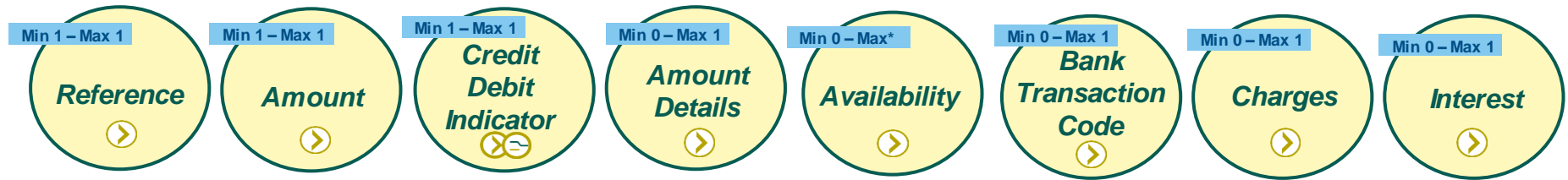

Additionally **Transaction Details** also has a variety of elements capturing details from the underlying transaction, which amongst other business transactions includes payment transaction data. For example **Remittance Information** and **Related Parties**

Notification > Entry > Entry Details > Transaction Details >

camt.054 Bank to Customer Debit Credit Notification – Related Parties & Related Agents

The Bank to Customer Debit Credit Notification message **Related Parties** and **Relegated Agents** represents a set of optional nested elements related to the underlying transaction. Where the **Entry Details** (the set of elements *Related Parties/Agents* belongs to) relate to a Payment, Clearing and Settlement (pacs) message, parties in the pacs messages can be transferred into the Cash Management (camt) message.

Min 0 – Max 1

Min 0 – Max 1



These **Related Parties** include : These **Related Agents** include :

- *Instructing Party*
- *Debtor*
- *Debtor Account*
- *Ultimate Debtor*
- *Creditor*
- *Creditor Account*
- *Ultimate Creditor*

- *Instructing Agent*
- *Instructed Agent*
- *Debtor Agent*
- *Creditor Agent*
- *Intermediary Agent 1*
- *Intermediary Agent 2*
- *Intermediary Agent 3*



Trading Party is also present in the **Related Parties** elements, and the following are present in the **Related Agents** elements: **Receiving Agents, Delivering Agent, Issuing Agent and Settlement Place**. Although these elements are not directly associated with a payment, as a Customer receiving a Statement related to other Business Domains e.g. a Security Settlement, it could be conceivable that these optional CBPR+ element may be populated



Notification ▶ Entry ▶ Entry Details ▶ Transaction Details ▶

Related Parties ▶

Related Agents ▶

camt.054 Bank to Customer Debit Credit Notification – other underlying data

The Bank to Customer Debit Credit Notification message **Entry Details** have a number of additional elements beyond **Related Parties** and **Related Agents** to capture information from the underlying payment.

These are:

- *Local Instrument*
- *Purpose*
- *Related Remittance Information*
- *Remittance Information*
- *Related Dates* such as the *Interbank Settlement Date*
- *Tax*

For *Payment Return* (pacs.004) it is also possible to capture **Return Information** which includes:

- The *Original Bank Transaction Code* of the original Entry
- The *Originator* of the return from the pacs.004
- And the *Reason* code.

Remittance Information as an end-to-end element should be passed unaltered from Payment Initiation (pain) into the Payment, Clearing and Settlement (pacs) message and onto the Bank to Customer Account Statement (camt) The Bank to Customer Debit Credit Notification may also capture this information. The *Remittance Information* element is common to these message sets.

Notification > Entry > Entry Details > Transaction Details >



camt.054 Bank to Customer Debit Credit Notification – other underlying data (continued)

It should also be mentioned that the Bank to Customer Credit Debit Notification message **Entry Details** have a number of additional elements which capture information from transactions in other business domains beyond payments, as well as have an element to capture **Additional Transaction Information**.



These are:

- *Related Quantity*
- *Financial Instrument Identification*
- *Corporate Action*
- *Safekeeping Account*
- *Cash Deposit*
- *Card Transactions*

Index of camt.054 Use Cases

Use case should be considered as a principal example whereby use case may be cross referenced

Debit/Credit Notification related to a Serial Customer Payments

Use Case c.54.1.1 – Customer Debit/Credit Notification (camt.054) of a Customer Credit Transfer (pacs.008)

Debit/Credit Notification related to a Serial Financial Institution Payments

Use Case c.54.2.1 – Customer Debit/Credit Notification (camt.054) of a FI to FI Credit Transfer (pacs.009)

Debit/Credit Notification related to a Cover Method Payments

Use Case c.54.3.1 – Customer Debit/Credit Notification (camt.054) of a payment using the cover method

Customer Debit/Credit Notification (camt.054) of a Customer Credit Transfer (pacs.008)

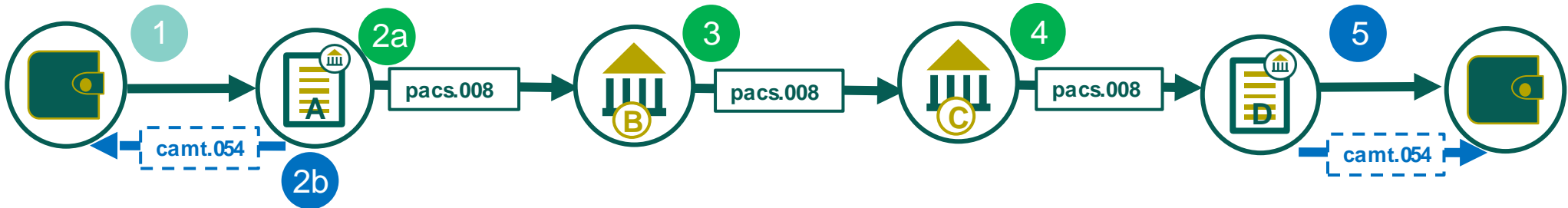

- 1 Debtor initiates a payment instruction to the Debtor Agent
- 2 Debtor Agent (A) initiates a serial payment towards the Creditor Agent (D) using Agents B & C as intermediaries
- 2a Agent A provides a debit notification to the debtor using the camt.054 to confirm their account has been debited for the payment initiation request. This notification may compliment additional status information or statement report messages
- 2b Agent A provides a debit notification to the debtor using the camt.054 to confirm their account has been debited for the payment initiation request. This notification may compliment additional status information or statement report messages
- 3 Agent B processes the payment on Agent C
- 4 Agent C processes the payment on Agent D
- 5 Agent D credits the account of the Creditor, providing a credit notification using the camt.054

Customer Debit/Credit Notification (camt.054) of a FI to FI Credit Transfer (pacs.009)

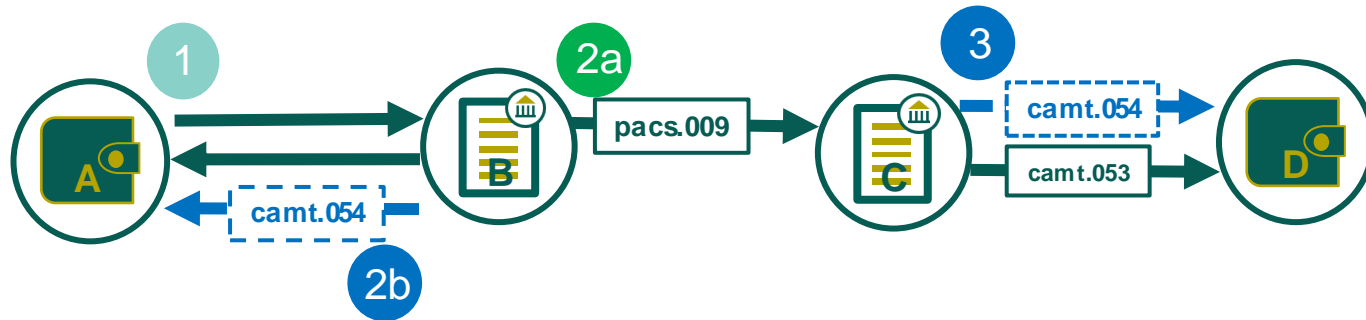

1 Agent A as the Debtor initiates a payment instruction to the Debtor Agent (Agent B)

2 Debtor Agent (B) debits the account of Agent A and initiates a serial payment towards the Creditor (Agent D) using Agent C as an intermediary.

2b Debtor Agent (Agent B) provides a debit notification to the debtor using the camt.054 to confirm their account has been debited for the payment initiation request. This notification may be complimented by an additional status information message. But typically will be compliment by an end of business day statement report messages

3 Creditor Agent (C) credits the account of Agent D and provides a credit notification (camt.054) in addition to an account statement (camt.053)

Customer Debit/Credit Notification (camt.054) of a payment using the cover method

Use Case c.54.3.1

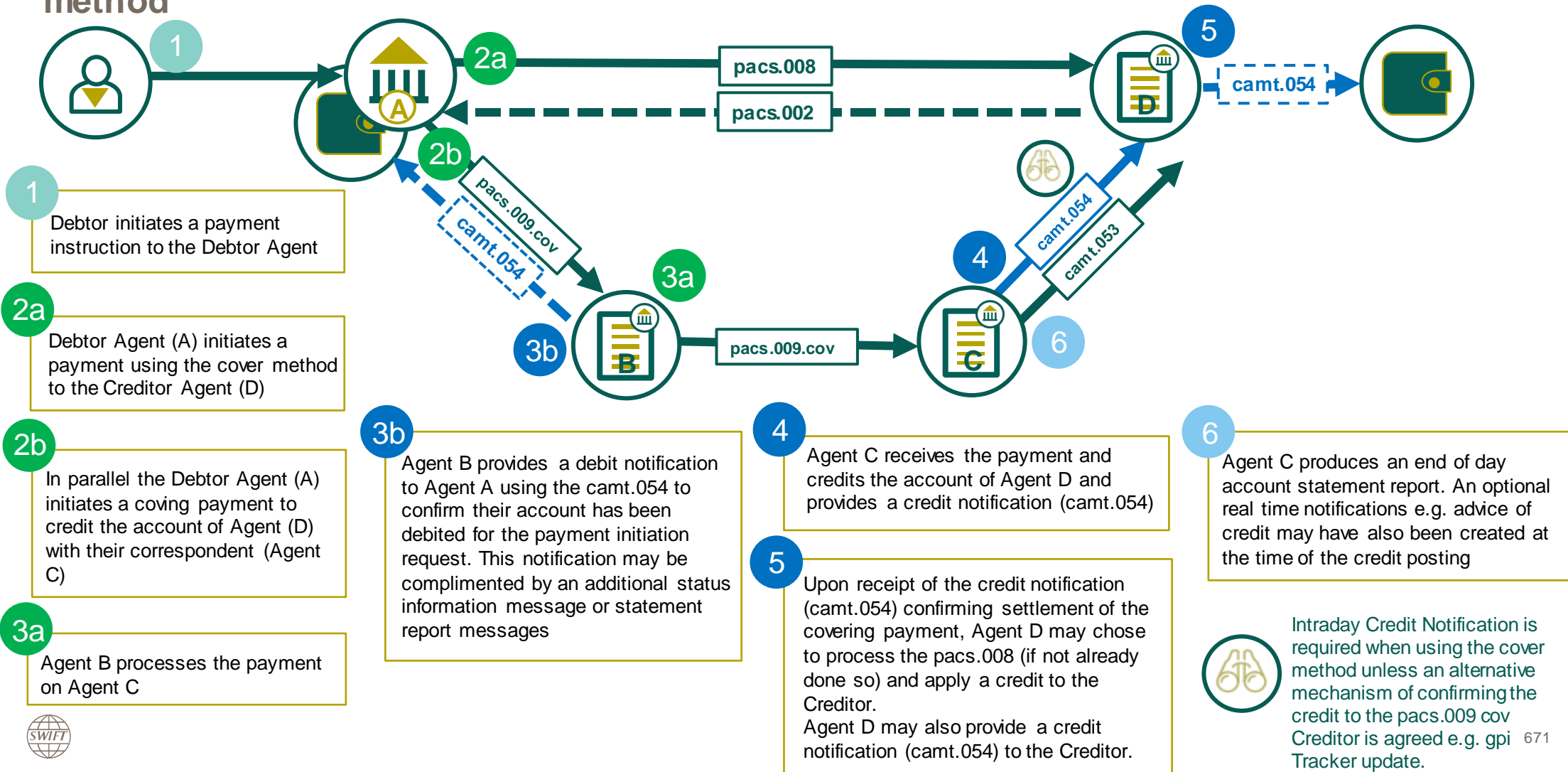

Intraday Credit Notification is required when using the cover method unless an alternative mechanism of confirming the credit to the pacs.009 cov Creditor is agreed e.g. gpi 671 Tracker update.

camt.057

Notification to Receive



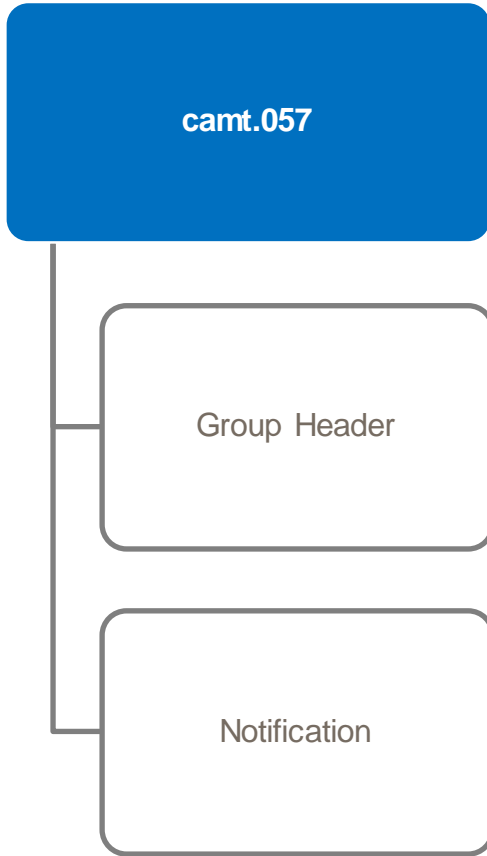

The *NotificationToReceive* message is sent by an account owner or by a party acting on the account owner's behalf to one of the account owner's account servicing institutions. It is an advance notice that the account servicing institution will receive funds to be credited to the account of the account owner. The *NotificationToReceive* message is used to advise the account servicing institution of funds that the account owner expects to have credited to its account.



The Notification to Receive message is the ISO 20022 equivalent of the legacy MT210 Notice to Receive. It can be cancelled using the camt.058 where in the meantime the legacy MT 292 can be used to request its cancellation.

High Level Notification to Receive (camt.057)

camt.057

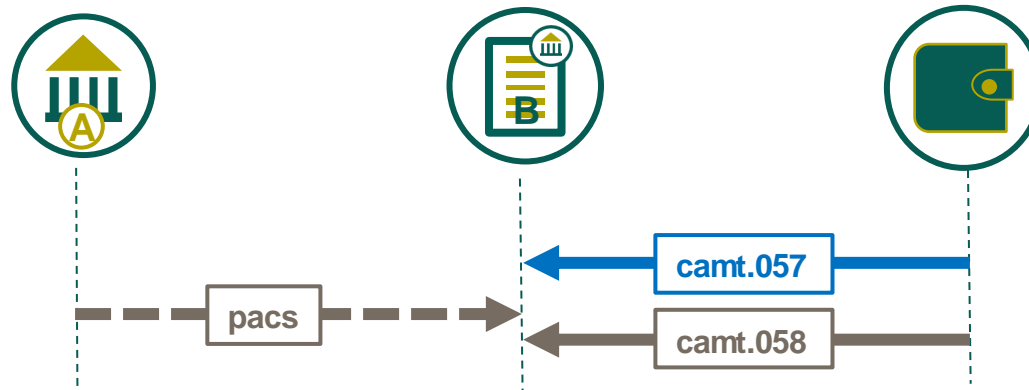

Role of the Creditor Agent and Creditor in the payment changes description in the Notification to Receive message (camt.057). The Account Owner is typically the Creditor and the Account Servicer is typically the Creditor Agent. This will be followed up with a pacs transferring the funds to the Account Servicer on the expected value date.

High Level message flow demonstrating the relationship of party roles between the payment message (pacs.008/pacs.009) and the Notification to Receive (camt.057)

Camt.057

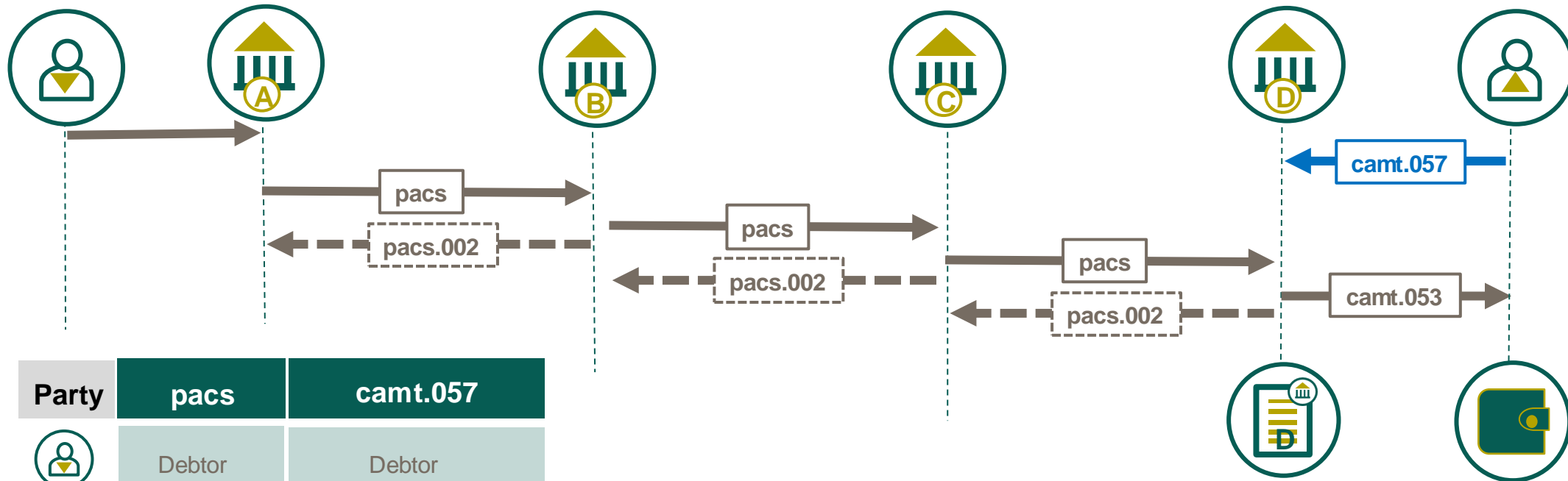

Party	pacs	camt.057
	Debtor	Debtor
	Debtor Agent	Debtor Agent
	Creditor Agent	Account Servicer
	Creditor	Account Owner

The Parties defined within the Notification to Receive (camt.0057) provide advance information to the Account Servicer of information included in the payment message. Noting a Debtor must always be present in the camt.057 (it is mandatory in the pacs payment message) but Debtor Agent may not be provided (Debtor Agent is mandatory in the pacs..08 but not he pacs.009)



Group Header



camt.057 Notification to Receive - Message Identification

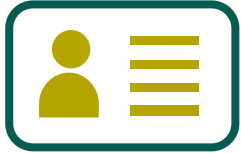

Each ISO 20022 cash management reporting message has a *Message Identification* element, located in the Group Header. This **35 character** identifier is a point-to-point reference used to unambiguously identify the message.

Min 1 – Max 1

The ***Message Identification*** in the Cash Management (camt) messages is equivalent to field 20 Transaction Reference Number of the MT 210 in the legacy MT Notice to Receive.

Group Header → Message Identification

camt.057 Notification to Receive – Creation DateTime

Min 1 – Max 1

The camt.057 message **Creation DateTime** captures the date and time which the message was created.

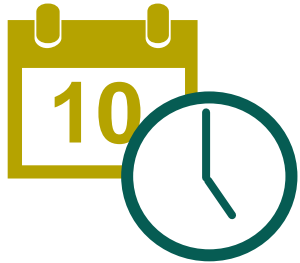

CBPR+ usage guidelines mandate the time zone that the time represents as an offset against Universal Time Coordinated (UTC):

Local time with UTC offset YYYY-MM-DDThh:mm:ss.sss+/-hh:mm

- For example: 2002-10-10T12:00:00-05:00 (noon/midday on 10 October 2002, Central Daylight Savings Time as well as Eastern Standard Time in the U.S.)



All CBPR+ time elements need offset against UTC. Milliseconds are optional.

Group Header ▶ Creation Date Time

camt.057 Notification to Receive – Message Sender

Min 0 – Max 1

The Notification to Receive **Message Sender** nested element provides details of the party that is sending the message, where the **Message Sender** is different from the account owner.

Where **Message Sender, Party** is used the nested:

- **Name** Min 0 – Max 1
- **Postal Address** Min 0 – Max 1
- **Identification** Min 0 – Max 1
- **Contact Details** Min 0 – Max 1

May be used to capture information related to this party.

Where **Message Sender, Agent** is used the nested **Financial Institution**:

- **BICFI** Min 1 – Max 1
- **Clearing System Member Identification** Min 0 – Max 1
- **LEI** Min 0 – Max 1

May be used to capture information related to this Agent.



Group Header	Message Sender
	Name
	Postal Address
	Identification
	Contact Details

Notification



camt.057 Notification to Receive – Notification

Min 1 – Max 1

The Notification to Receive **Notification** element contains nested elements to provide further details on the account notification such as the related parties, the expected amount to be received and value date of the expected receipt.



The Notification nested element **Item** can contain multiple Credits. Where there is only one expected credit then only the Item element will contain the **Item Identification** and the **Amount**.



Today the status of a camt.057 has no documented ISO 20022 reporting process, to the Account Owner by the Account Servicer. Generally, if the Account Servicer does not require notification the message will be ignored.

Notification 

camt.057 Notification to Receive – Notification Identification

Min 1 – Max 1

The Notification to Receive message **Notification Identification** provides a mandatory element to identify the account notification.



Unique reference assigned by the account owner to unambiguously identify the account notification. There is no equivalent in the MT210. It is recommended that the Message Identification is repeated for the Notice to Receive Identification.

camt.057 Notification to Receive - Account

Min 0 – Max 1

The Notification to Receive message **Account** element provides nested elements to identify the account for which the credit entry has been made. The following two mandatory elements are nested beneath **Account**.

Min 1 – Max 1

a unique **Identification** for the account, between the Account Servicer and Account Owner. The element is further nested by choice of **IBAN** or **Other** to capture the account.

An element which may either use an external ISO Cash Account Type code or a proprietary code. It is used to identifier a particular type of account.

The **Currency** for which the account is held. This is identified using the three characters ISO currency code.

The Name of the Account, as Assigned by the servicing institution.

A nested element which contains a Proxy Identifier together with the Proxy Type represented by either use an external ISO Proxy Account Type code or a proprietary code.

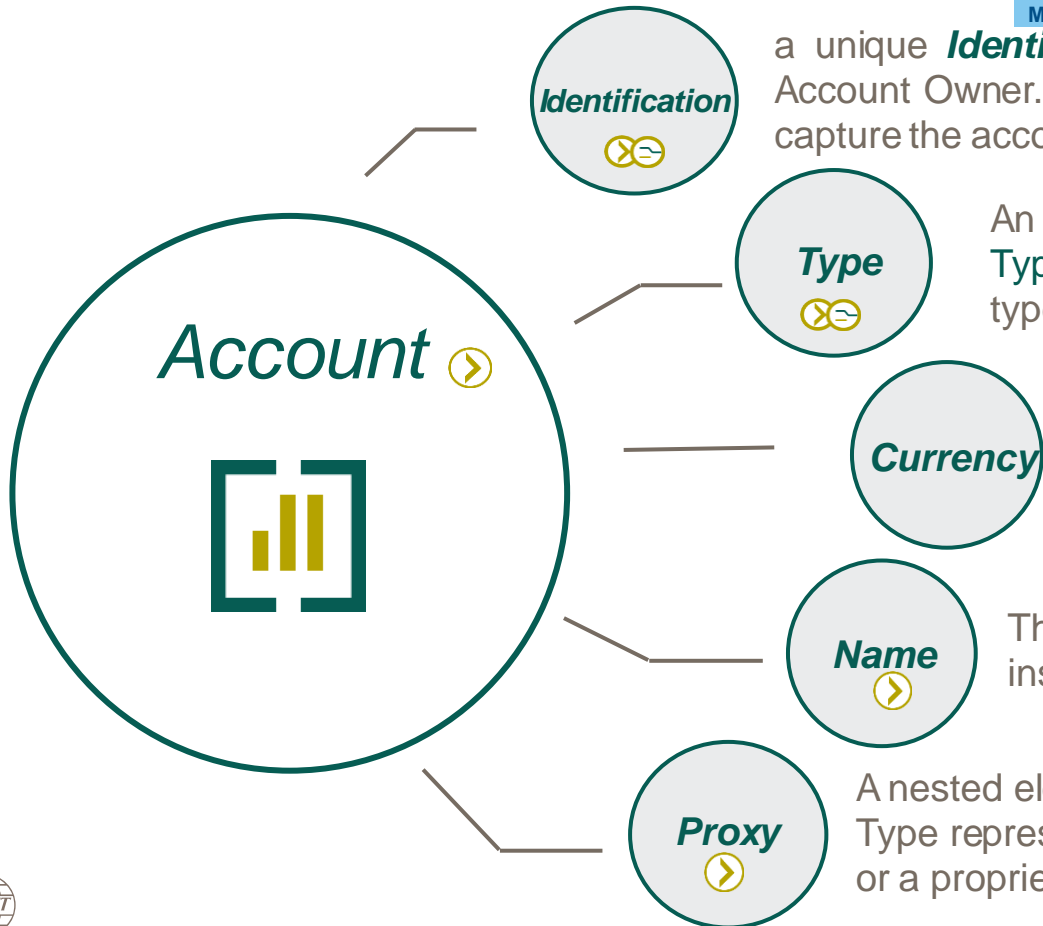

Notification > Account >

camt.057 Notification to Receive – Account Owner and Account Servicer

Min 0 – Max 1

The **Account Owner** is the Creditor, and the **Account Servicer** is the Creditor Agent. They are static roles in the camt.057 Notification to Receive.

Min 0 – Max 1

The **Account Owner** must be identified either by the Party name and postal address or as an Agent using a Financial Institution identification. The **Account Servicer** must be identified as an Agent by using the Financial Institution identification.



The Account Owner and the Account Servicer are the Creditor and Creditor Agent respectively in a pacs.008 FI to FI Customer. Where utilised, it is **recommended** to use the element at the Item level.

Notification 

 Account Owner

 Account Servicer

camt.057 Notification to Receive – Related Account

Min 0 – Max 1

The Notification to Receive message **Related Account** element allows the identification of a related parent account for the account notification. For example sweeping, pooling or virtual account for which the notification is produced can identify the parent account they hierarchically relate to.

In the context of a Notification to Receive this element provides little business value.



When **Related Account** is utilized, like **Account**, the **Identification** and **Currency** element become mandatory.

Min 1 – Max 1

Min 0 – Max 1

Additionally, the nested **Type** element, **Name** and nested **Proxy** element are optionally available.

Min 0 – Max 1

Min 0 – Max 1

Min 0 – Max 1



Related Account uses a variety of common elements described in more detail within the *Account* section.

Notification > Related Account ✓

Identification ✓

Type ✓

Currency ✓

Name

685

Proxy >



camt.057 Notification to Receive – Total Amount and Expected Value Date

Min 0 – Max 1

The Notification to Receive message **Total Amount** provides the sum of all the amounts of all the **Item** entries. Where utilised the **Item** element is a mandatory element which contains information about the expected receipt. The Notification to Receive can contain multiple items. **Expected Value Date** is the date on which the final receiving agent expects to receive the total amount.

Min 0 – Max 1



The Total Amount provides a control total where there are multiple credits recorded within the Item element. The Total Amount element should not be used where there is a single expected credit.



The **Expected Value Date** takes the format YYYY-MM-DD

Notification > Total Amount ✓

Notification > Expected Date

camt.057 Notification to Receive – Debtor

The Notification to Receive message describes the **Party** or **Agent** that owes the amount of money as the **Debtor**. The following describes the *Debtor* nested **Party** elements in greater detail.

Mandatory **Name** (where a BIC identifier is not provided) by which the party is known

Nested element capturing either structured or unstructured *Debtor* address details

Nested element capturing the various types of identifiers for the party e.g. BIC, LEI etc.

Optional element to capture the Debtor's ISO country code of residence

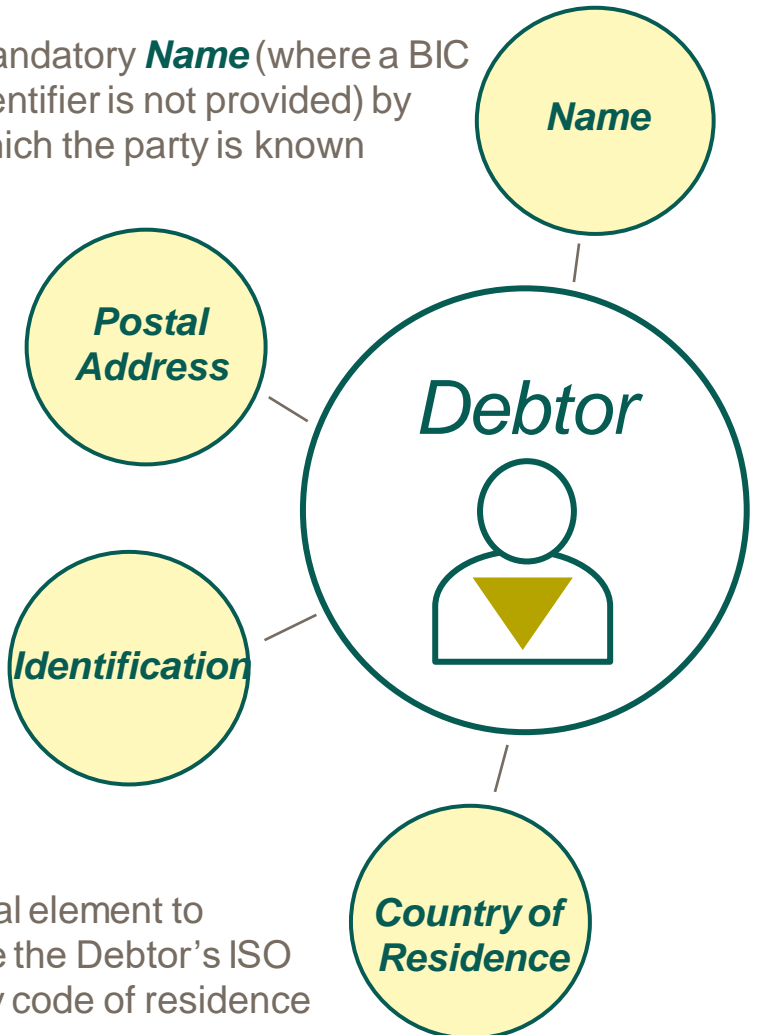
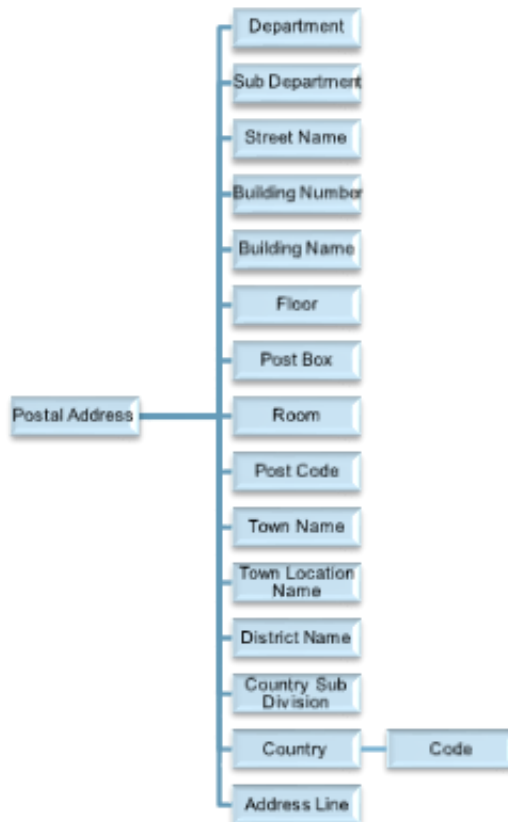

camt.057 Notification to Receive – Debtor

The Notification to Receive message describes the **Party** or **Agent** that owes the amount of money as the **Debtor**. The following describes the **Debtor** nested **Agent** elements in greater detail.

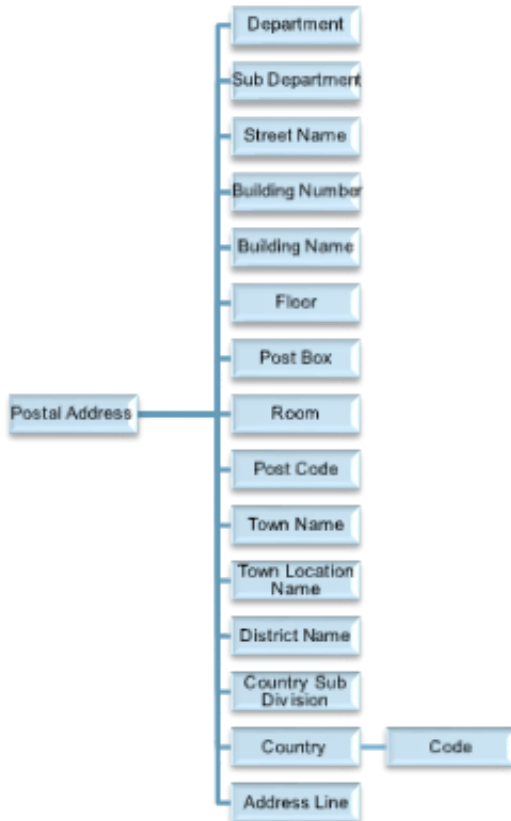

Information used to identify a Debtor by a clearing system identifier.

The BIC which identifies the Debtor

Legal entity identifier of the financial institution.

Name by which the Agent is known

Nested element capturing either structured or unstructured Debtor address details

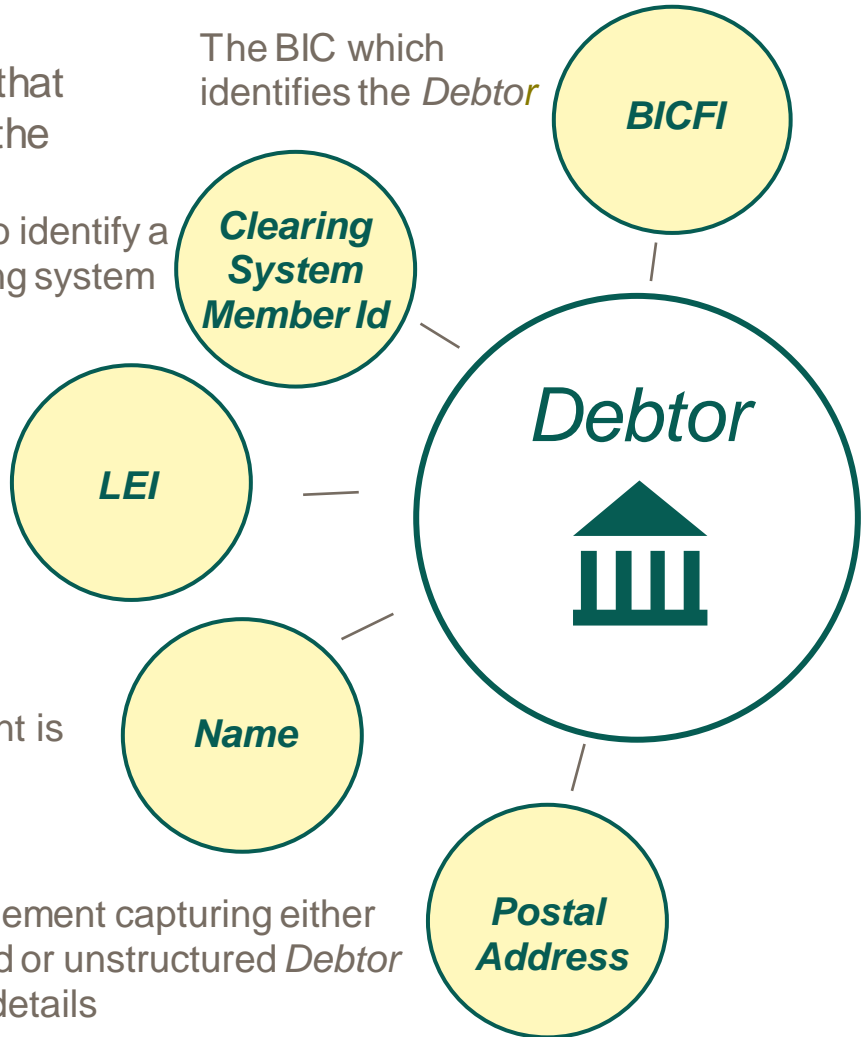

camt.057 Notification to Receive – Debtor Agent and Intermediary Agent



Min 0 – Max 1

The **Debtor Agent** element in the camt.057 Notification to Receive captures the Debtor Agent of the payment i.e., the Financial Institution servicing an account for the Debtor.

The **Debtor Agent** and **Intermediary Agent** elements allow the Treasury function at the Creditor Agent to chase up the actual payment if it fails to arrive at the scheduled time.



Min 0 – Max 1

The **Intermediary Agent** element in the camt.057 Notification to Receive capture the Intermediary agent between the Debtor Agent and the Account Servicer i.e. the Agent from whom the Creditor Agent expects to receive the payment from.

The **Debtor Agent** and **Intermediary Agent** elements allow the Treasury function at the Creditor Agent to chase up the actual payment if it fails to arrive at the scheduled time.



The **Debtor Agent** and **Intermediary Agent** elements allow the Account Servicing Institution's Treasury department to proactively follow up, as necessary, the actual payment if it fails to arrive by an expected time.



Notification 

 Debtor Agent

 Creditor Agent

camt.057 Notification to Receive – Item

Min 1 – Max *

The Notification to Receive message mandatory **Item** element provides details of the expected amount on the account serviced by the account servicer. There is no equivalent field in the legacy MT210 Notice to Receive.



The various nested elements within the **Item** element are very useful in the case where there are multiple credits. The Creditor Agent will be able to reconcile the incoming receipts against the list of expected receipts detailed in the **Item** element and will be able to check completeness of all expected receipts and identify any missing receipts.



A single occurrence of **Item** should be used unless bilaterally agreed.

Notification	Item
Identification	
Type	
Currency	

camt.057 Notification to Receive – Item

The Notification to Receive message mandatory **Item** element provides details of the expected amount on the account serviced by the account servicer. There is no equivalent field in the legacy MT210 Notice to Receive.



Only the **Identification** and **Amount** elements are mandatory.

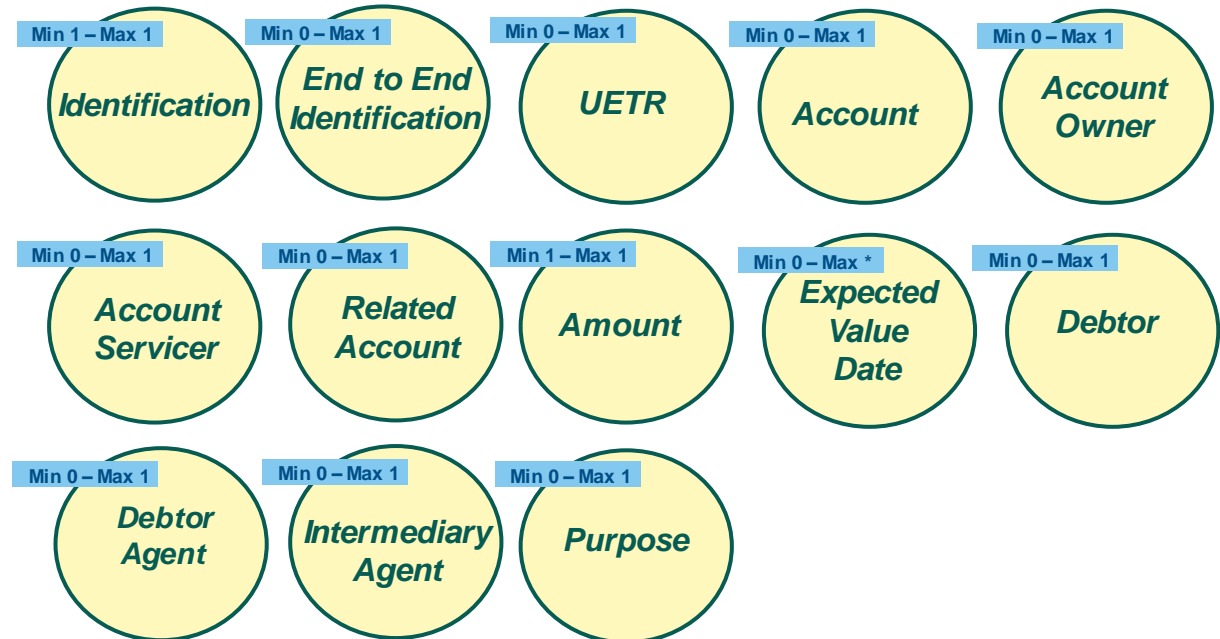

Notification > Item >

Index of camt.057 Use Cases

Use case should be considered as a principal example whereby use case may be cross referenced

Notification to Receive multiple receipts

Use Case c.57.1.1 – Notification to Receive (camt.057) followed by Customer Credit Transfers (pacs.008)

Use Case c.57.1.2 – Notification to Receive (camt.057) followed by FI Credit Transfers (pacs.009)

Use Case c.57.1.3 – Notification to Receive (camt.057) where the receipt is settled by the cover method.

Use Case c.57.1.4 – Notification to Receive (camt.057) for a FI Credit Transfers cover (pacs.009 cov).

Notification to Receive (camt.057) followed by Customer Credit Transfers (pacs.008)



1 Creditor is expecting to receive a payment from the Debtor. As the Account Owner sends a Notification to Receive to Agent C as Account Servicer.

3 Debtor Agent (A) initiates a serial payment towards the Creditor Agent (C) using Agents B as an intermediary.

5 Creditor Agent (C) as Account Servicer sends and end of day statement to Creditor as Account Owner confirming accounting entries.

2 Debtor initiates a payment instruction to the Debtor Agent (A).

4 Agent (B) processes the payment on to the Creditor Agent (C).

Notification to Receive (camt.057) followed by FI Credit Transfers (pacs.009)

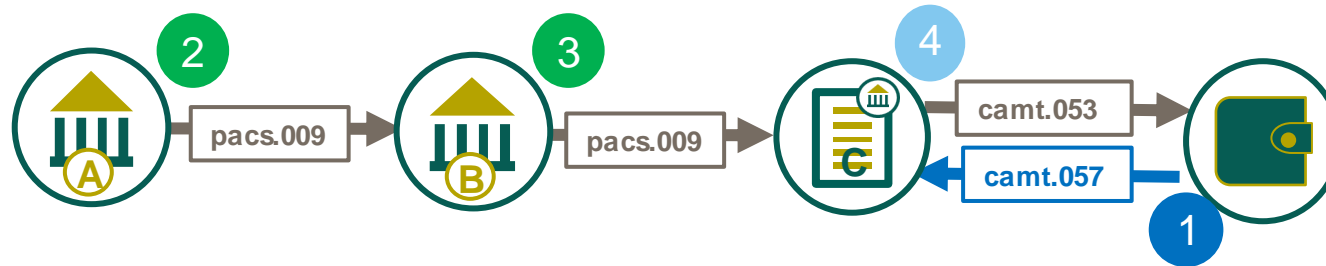

1 Creditor is expecting to receive a payment from Debtor. As the Account Owner sends a Notification to Receive to Agent C as Account Servicer.

2 Debtor (A) initiates a serial payment towards the Creditor Agent (C) using Agents (B) as an intermediary.

3 Agent (B) processes the payment on to the Creditor Agent (C).

4 Creditor Agent (C) as Account Servicer sends end of day statement to Creditor as Account Owner confirming accounting entries.

Notification to Receive (camt.057) where the receipt is settled by the cover method.

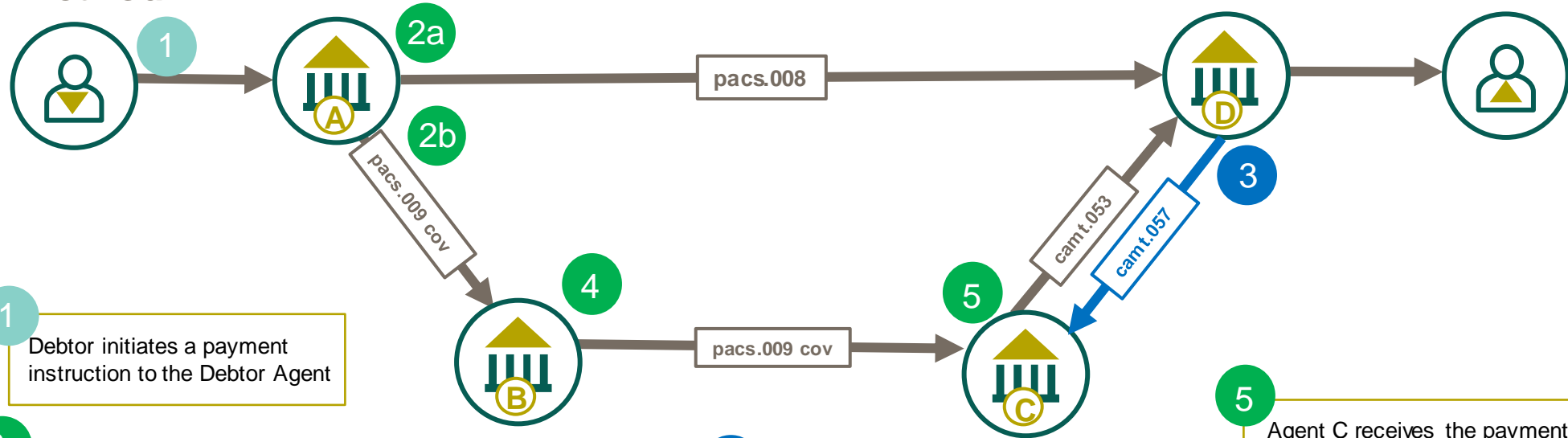

1 Debtor initiates a payment instruction to the Debtor Agent

2a Debtor Agent (A) initiates a payment using the cover method to the Creditor Agent (D)

2b In parallel the Debtor Agent (A) initiates a covering payment to credit the account of Agent (D) who become the Creditor of the cover payment (pacs.009 cov). Agent A's role also changes in the cover payment where it becomes the Debtor, whereby Agent A's account with their correspondent (Agent B) is debited.

3 Upon receipt of the pacs.008 advising settlement will occur via a cover payment. Agent D sends a Notification to Receive to Agent C.

4 Agent B processes the payment on to Agent C

5 Agent C receives the payment and credits the account of Agent D as the Creditor, producing an end of day account statement report. An optional real time notifications e.g. advice of credit may have also been created at the time of the credit posting.



Notification to Receive (camt.057) for a FI Credit Transfers cover (pacs.009 cov).

Use Case c.57.1.4

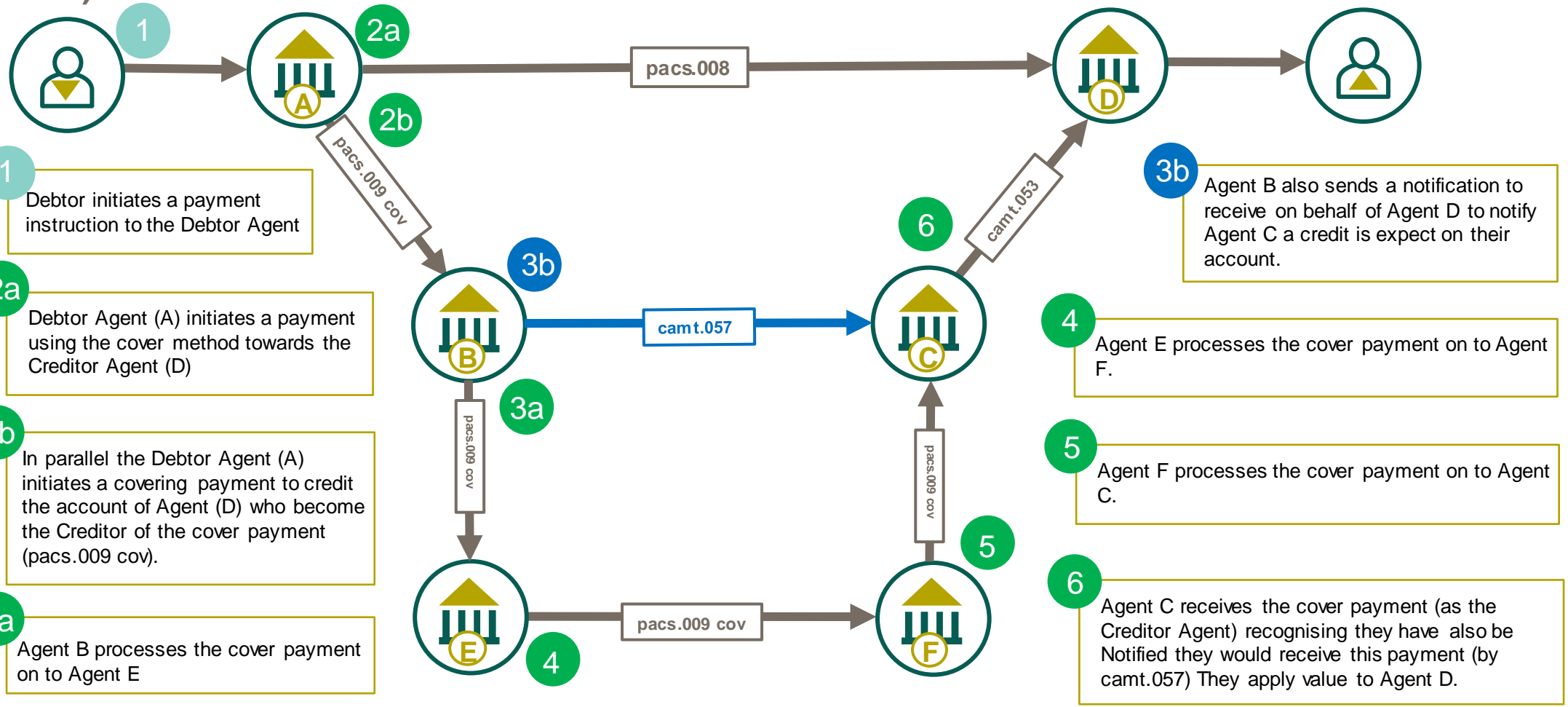

camt.058



Notification to Receive Cancellation Advice



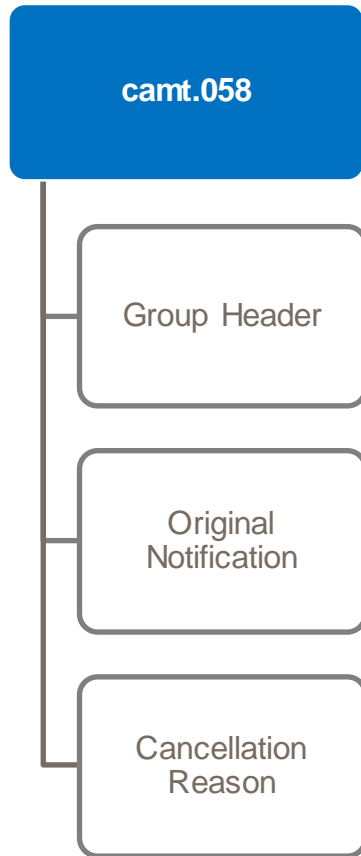

The *Notification To Receive Cancellation Advice* message is sent by an account owner or by a party acting on the account owner's behalf to one of the account owner's account servicing institutions. It is used to advise the account servicing institution about the cancellation of a notification sent in a previous *Notification To Receive* message.

High Level Notification to Receive Cancellation Advice (camt.058)

camt.058

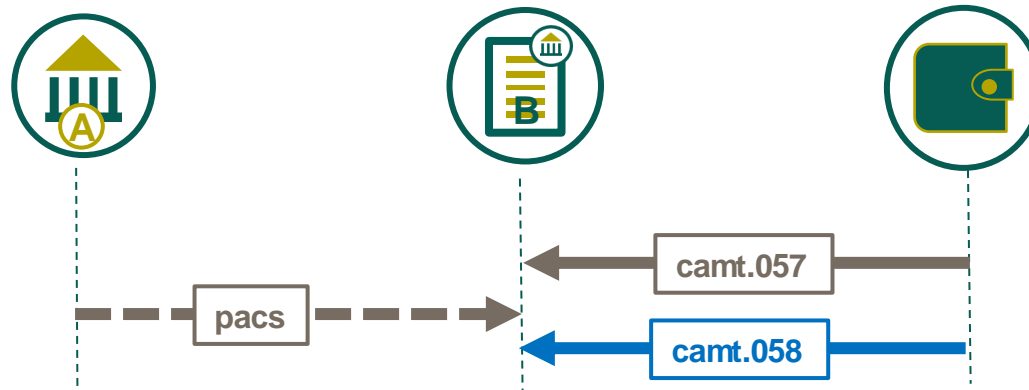

Role of the Creditor Agent and Creditor in the payment changes description in the Notification to Receive message (camt.057). The Account Owner is typically the Creditor and the Account Servicer is typically the Creditor Agent. The Notification to Receive Cancellation Advice (camt.058) is used to request the cancellation of a previous Notification to Receive.

Group Header



camt.058 Notification to Receive Cancellation Advice - Message Identification

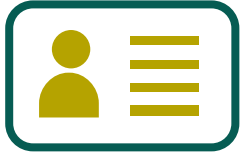

Each ISO 20022 cash management reporting message has a *Message Identification* element, located in the Group Header. This **35 character** identifier is a point-to-point reference used to unambiguously identify the message.

Min 1 – Max 1

The ***Message Identification*** in the Cash Management (camt) messages is equivalent to field 20 Transaction Reference Number of the MT 292 in the legacy MT Request for Cancellation.

Group Header → Message Identification

camt.058 Notification to Receive Cancellation Advice – Creation DateTime

Min 1 – Max 1

The camt.058 message **Creation Date Time** captures the date and time which the message was created.

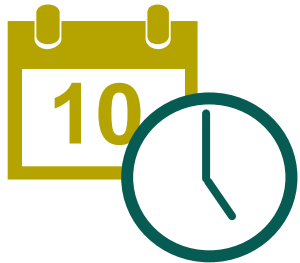

CBPR+ usage guidelines mandate the time zone that the time represents as an offset against Universal Time Coordinated (UTC):

Local time with UTC offset **YYYY-MM-DDThh:mm:ss.sss+/-hh:mm**

- For example: 2002-10-10T12:00:00-05:00 (noon/midday on 10 October 2002, Central Daylight Savings Time as well as Eastern Standard Time in the U.S.)



All CBPR+ time elements need offset against UTC. Milliseconds are optional.

Group Header ▶ Creation Date Time

camt.058 Notification to Receive Cancellation Advice – Message Sender



Min 0 – Max 1

The Notification to Receive Cancellation Advice **Message Sender** nested element provides details of the **Party** or **Agent** that is sending the message, where the **Message Sender** is different from the account owner.

This element has no equivalent in the legacy MT 292 Request for Cancellation.

Where **Message Sender, Party** is used the nested:

- **Name** Min 0 – Max 1
- **Postal Address** Min 0 – Max 1
- **Identification** Min 0 – Max 1
- **Contact Details** Min 0 – Max 1

May be used to capture information related to this party.

Where **Message Sender, Agent** is used the nested **Financial Institution**:

- **BICFI** Min 1 – Max 1
- **Clearing System Member Identification** Min 0 – Max 1
- **LEI** Min 0 – Max 1

May be used to capture information related to this Agent.



Group Header	Message Sender
	Name
	Postal Address
	Identification
	Contact Details



Original Notification



camt.058 Notification to Receive Cancellation Advice – Original Notification

Min 1 – Max 1

The Notification to Receive Cancellation Advice **Original Notification** element contains nested elements to provide further details on the original camt.057 notification to receive. such as the related parties, the expected amount to be received and value date of the expected receipt.

The **Original Notification** nested element enables the ability to reconcile this cancellation advice against the Notification originally received, so that appropriate action can be take to remove the advised currency and amount from predicted currency positions at the Account Servicer.



Group Header

- *Message Identification*
- *Creation Date Time*

Notification

- *Identification*

- *Debtor*

Item

- *Identification*
- *End to End Identification*
- *UETR*
- *Amount*
- *Expected Value Date*
- *Debtor*

Original Notification

- *Original Message Identification*
- *Original Creation Date Time*

- *Original Notification Identification*
- *Original Notification Reference*

- *Debtor*

- *Original Item*

- *Original Item Identification*
- *Original End to End Identification*
- *UETR*
- *Amount*
- *Expected Value Date*
- *Debtor*

Original Notification



camt.058 Notification to Receive Cancellation Advice – Original Message Identification

Min 1 – Max 1

The Notification to Receive Cancellation Advice message **Original Message Identification** provides a mandatory element to identify the Message Identification from the original camt.057.



This **35 character** identifier is a point-to-point reference used to unambiguously identify the Notification to Receive message, capture in its group header.

Original Notification 

Original Message Identification

camt.058 Notification to Receive Cancellation Advice – Original Creation DateTime

Min 0 – Max 1

The camt.058 message **Original Creation Date Time** captures the date and time which the original Notification to Receive message was created.

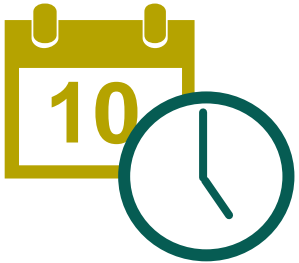

CBPR+ usage guidelines mandate the time zone that the time represents as an offset against Universal Time Coordinated (UTC):

Local time with UTC offset YYYY-MM-DDThh:mm:ss.sss+/-hh:mm

- For example: 2002-10-10T12:00:00-05:00 (noon/midday on 10 October 2002, Central Daylight Savings Time as well as Eastern Standard Time in the U.S.)



All CBPR+ time elements need offset against UTC. Milliseconds are optional.

Original Notification 

Original Creation DateTime

camt.058 Notification to Receive Cancellation Advice – Original Notification Identification

Min 1 – Max 1

The Notification to Receive Cancellation Advice message **Original Notification Identification** provides a mandatory element to identify the account notification.



Unique reference assigned by the account owner to unambiguously identify the original account notification.

Original Notification 

Original Notification Identification

camt.058 Notification to Receive Cancellation Advice – Debtor

The Notification to Receive message describes the **Party** or **Agent** that owes the amount of money as the **Debtor**. The following describes the **Debtor** nested **Party** elements in greater detail.

Mandatory **Name** (where a BIC identifier is not provided) by which the party is known

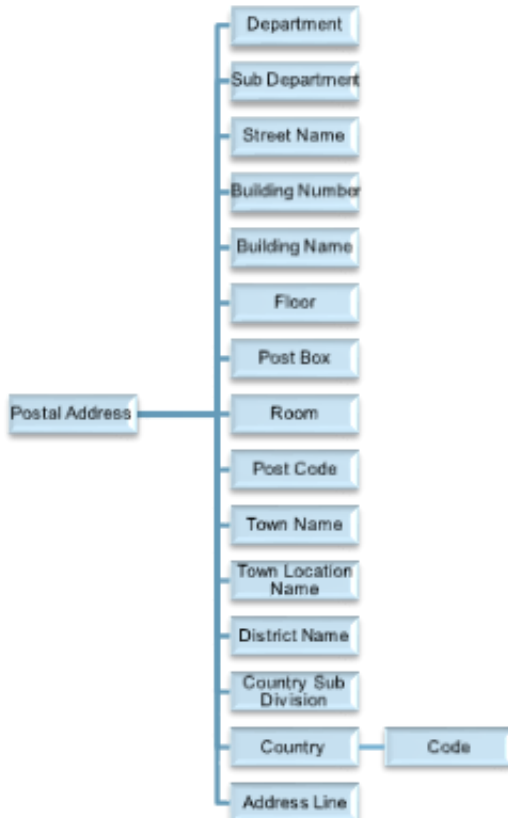

Nested element capturing either structured or unstructured **Debtor** address details

Nested element capturing the various types of identifiers for the party e.g. BIC, LEI etc.

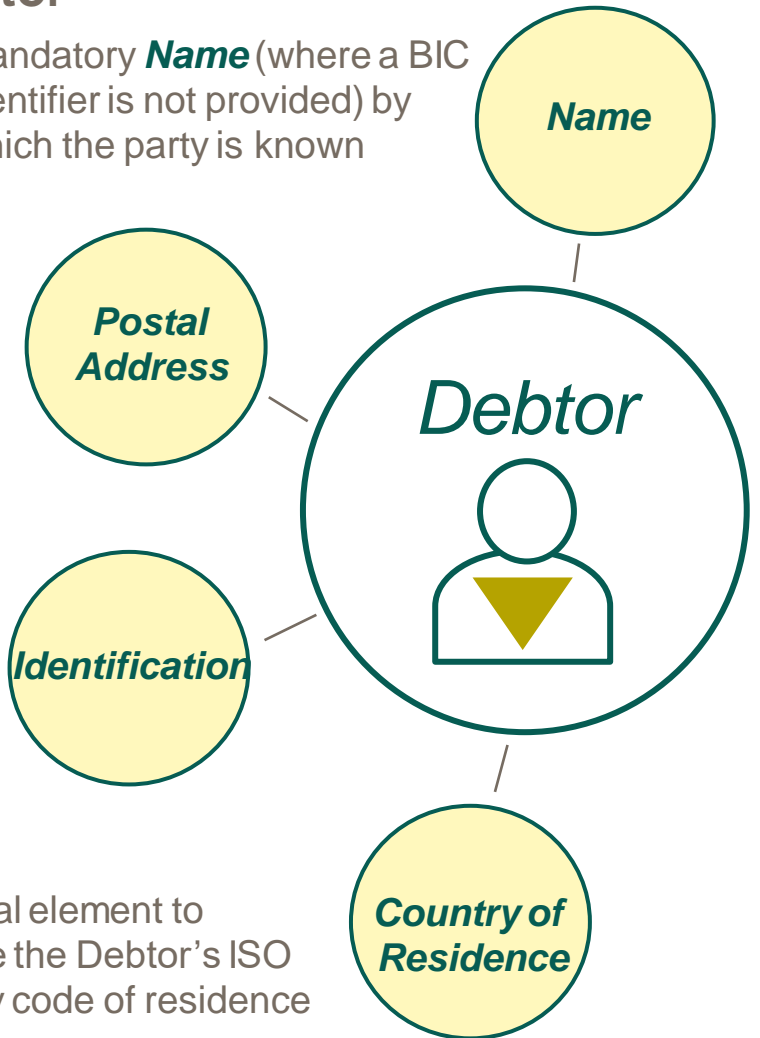

Optional element to capture the Debtor's ISO country code of residence



Debtor is required either within the **Original Notification Reference** nested element or within the **Original Item** nested element

Original Notification > Original Notification Reference > Debtor

> Party

camt.058 Notification to Receive Cancellation Advice – Debtor

The Notification to Receive message describes the **Party** or **Agent** that owes the amount of money as the **Debtor**. The following describes the **Debtor** nested **Agent** elements in greater detail.

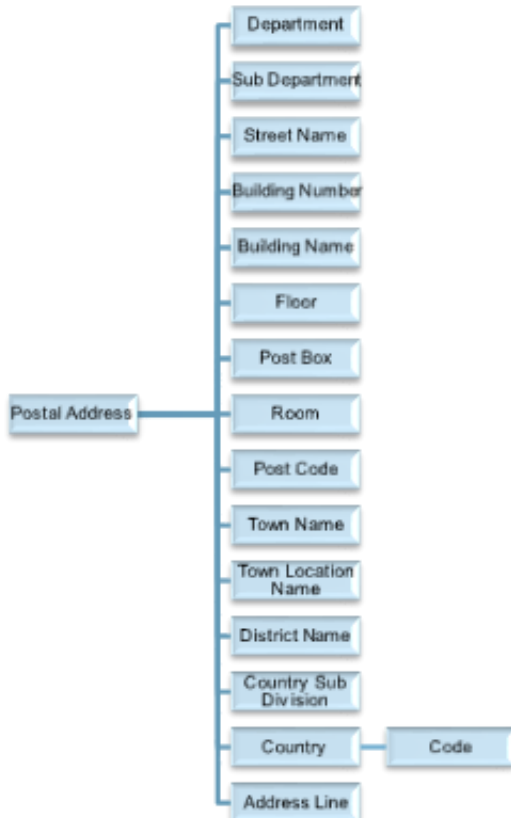

Information used to identify a Debtor by a clearing system identifier.

The BIC which identifies the *Debtor*

Legal entity identifier of the financial institution.

Name by which the Agent is known

Nested element capturing either structured or unstructured *Debtor* address details

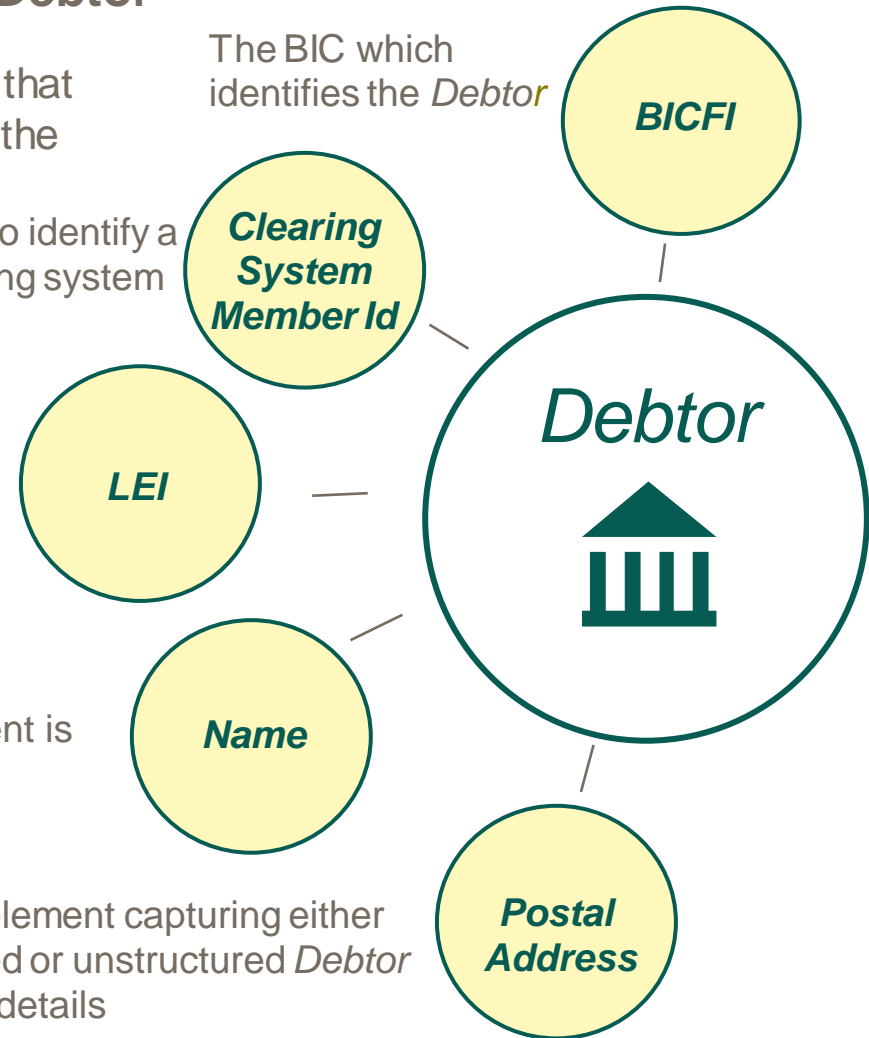

Debtor is required either within the **Original Notification Reference** nested element or within the **Original Item** nested element

Original Notification Original Notification Reference Debtor Agent

camt.058 Notification to Receive Cancellation Advice – Debtor Agent



Min 0 – Max 1

The **Debtor Agent** element in the camt.058 Notification to Receive Cancellation Advice captures the Debtor Agent provided in the original Notification to Receive (camt.057) i.e., the Financial Institution servicing an account for the Debtor.



Debtor Agent may be provided within the **Original Notification Reference** nested element or within **the Original Item** nested element.

Original Notification

Original Notification Reference



camt.058 Notification to Receive Cancellation Advice – Original Item Reference

Min 1 – Max 1

The Notification to Receive Cancellation Advice **Original Item Reference** nested element captures the references of the Original Item in the original Notification to Receive message.

Min 1 – Max *

The **Original Item** nested element is repetitive as the original Notification to Receive message has the ability to notify on more than one item i.e. currency and amount expect. The following elements are nested within **Original Item**, of which **Identification** and **Amount** are required.

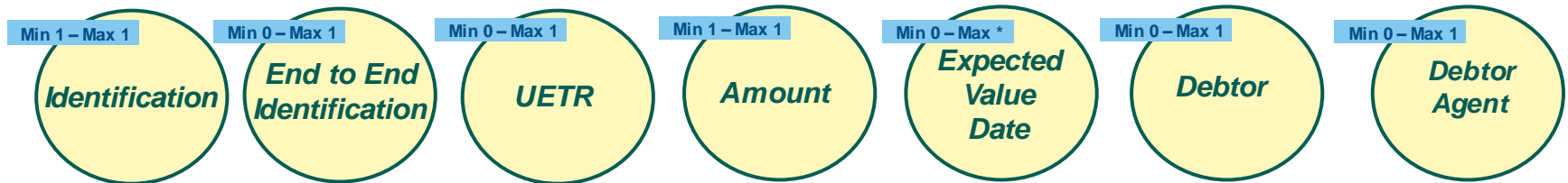

Debtor is required either within the **Original Notification Reference** nested element or within the **Original Item Reference** nested element.

Original Notification

Original Notification Reference

Original Item



Cancellation Reason



camt.058 Notification to Receive Cancellation Advice – Cancellation Reason

Min 1 – Max 1

The Notification to Receive Cancellation Advice **Cancellation Reason** nested element captures information associated with the reason for the Cancellation request.

Min 0 – Max 1



the **Originator** element helps identify the party who issued the Cancellation request. Typically, this element would be used to identify the Account Owner as the Originator of the request, where the Notification to Receive Cancellation Advice message captured a **Message Sender** acting on the account owner's behalf.

Min 1 – Max 1

the **Reason** is mandatory and represented by an embedded CBPR+ Cancellation **Code** choice (↔)

Min 0 – Max 2



The **Additional Information** element may also be included to provide further details on the Cancellation reason.



Note where Reason code NARR is used additional information must be provided to describe the reason for the Cancellation request.

Cancellation Reason ✓

▶ Originator

Reason

Additional Information

Index of camt.058 Use Cases

Use case should be considered as a principal example whereby use case may be cross referenced

Notification to Receive multiple receipts

Use Case c.58.1.1 – Cancellation Advice for a Notification to Receive (camt.057) expecting a Customer Credit Transfers (pacs.008)

Use Case c.58.1.2 – Cancellation Advice for a Notification to Receive (camt.057) expecting a FI Credit Transfers (pacs.009)

Use Case c.58.1.3 – Cancellation Advice for a Notification to Receive (camt.057) where the receipt is settled by the cover method.

Cancellation Advice for a Notification to Receive (camt.057) expecting a Customer Credit Transfers (pacs.008)

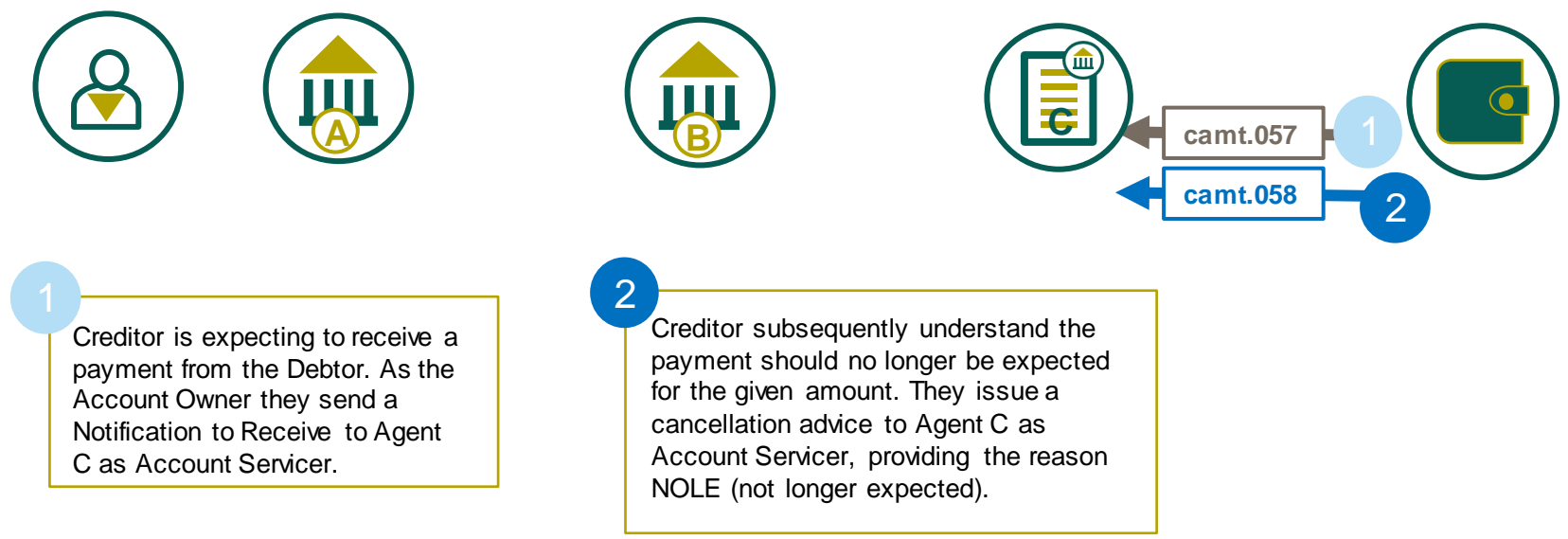

Cancellation Advice for a Notification to Receive (camt.057) expecting a FI Credit Transfers (pacs.009) Use Case c.58.1.2

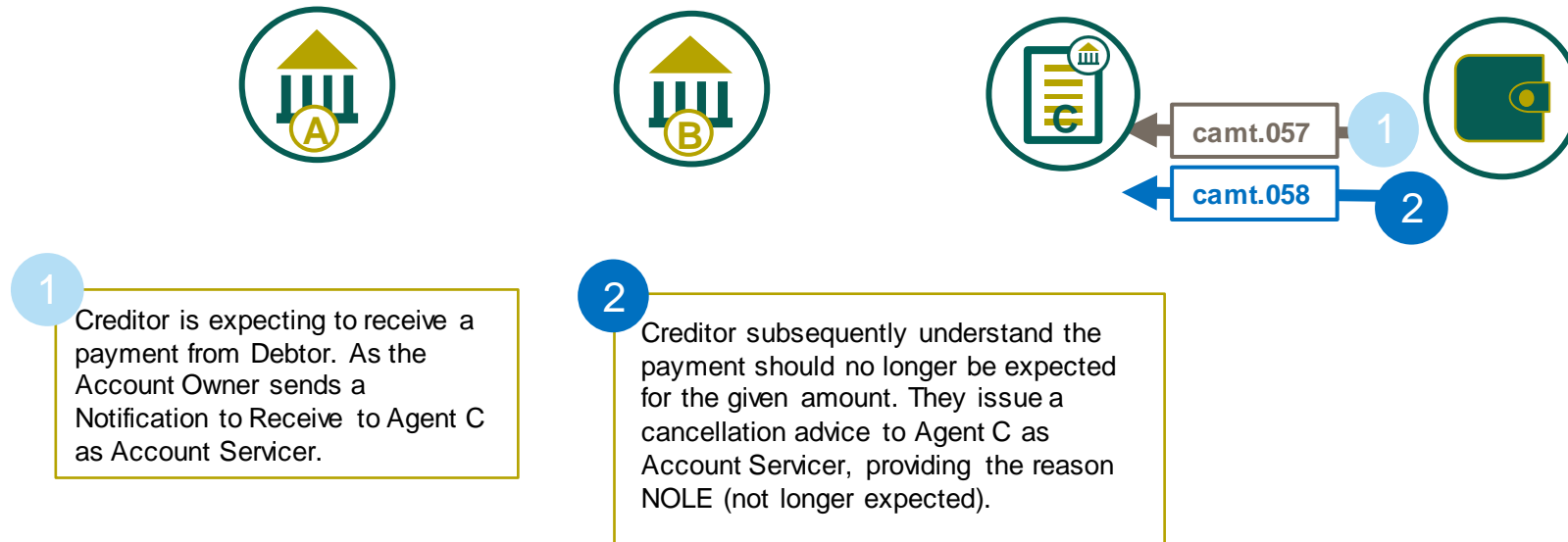

Cancellation Advice for a Notification to Receive (camt.057) where the receipt is settled by the cover method.

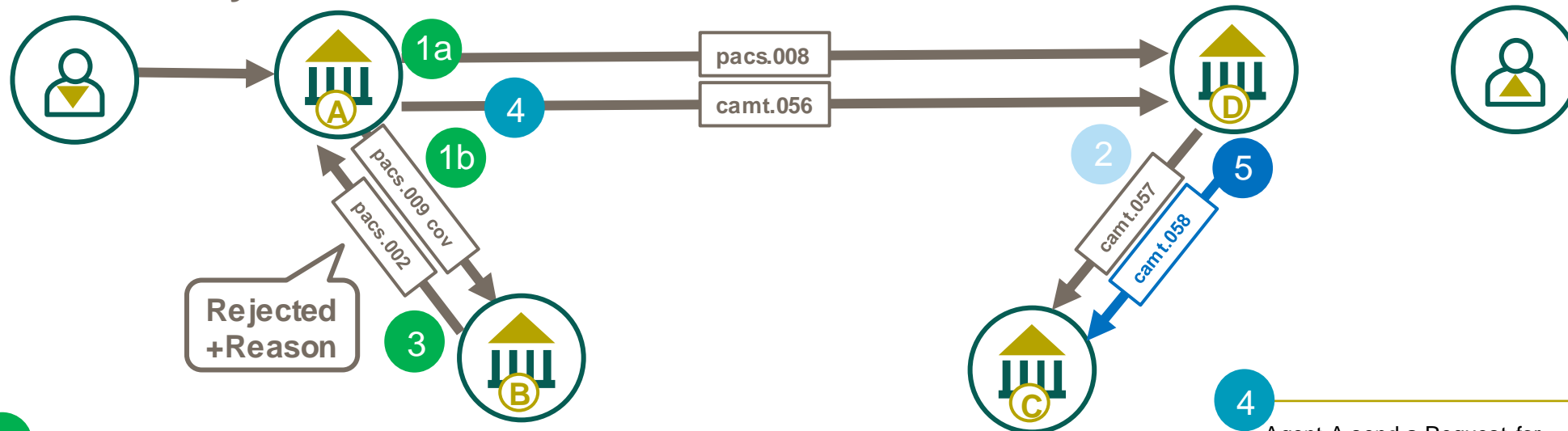

1a Debtor Agent (A) initiates a payment using the cover method to the Creditor Agent (D)

1b In parallel the Debtor Agent (A) initiates a covering payment to credit the account of Agent (D) who become the Creditor of the cover payment (`pacs.009 cov`). Agent A's role also changes in the cover payment where it becomes the Debtor, whereby Agent A's account with their correspondent (Agent B) is debited.

2 Upon receipt of the `pacs.008` advising settlement will occur via a cover payment. Agent D sends a Notification to Receive to Agent C.

3 Agent B rejects the payment advising Agent A

4 Agent A send a Request for Cancellation to Agent D including the reason COVR to confirm the cover payment was cancelled.

5 Agent D subsequently issue a cancellation advice to Agent C as Account Servicer, providing the reason NOLE (not longer expected).



camt.060

Account Reporting Request



camt.060 Account Report Request

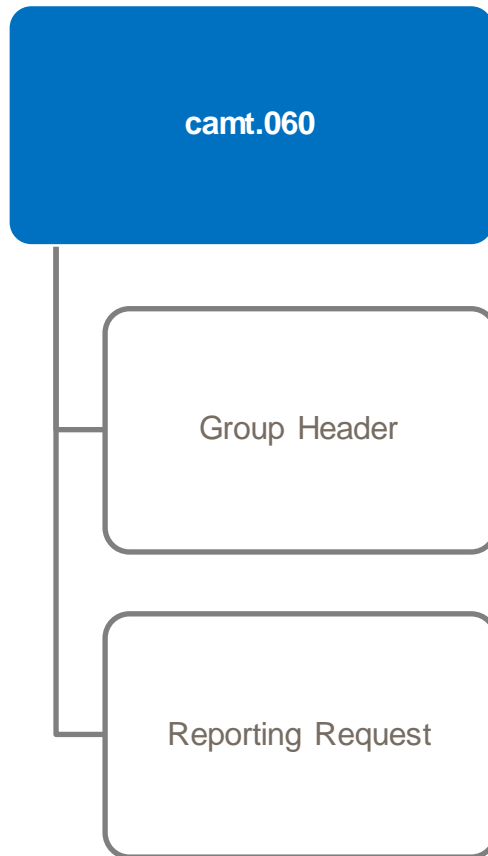

The AccountReportingRequest message is sent by the account owner, either directly or through a forwarding agent, to one of its account servicing institutions. It is used to ask the account servicing institution to send a report for the account owner's account:

- BankToCustomerAccountReport (camt.052) or
- BankToCustomerStatement (camt.053) or
- BankToCustomerDebitCreditNotification (camt.054).



Account reports are often configured by the Account Servicing Institution as part of a static configuration. The Account Report Request could however be used as an alternative mechanism to request reports on a frequent or ad hoc basis.

Account Report Request can contain multiple *Reporting Request* elements as the maximum multiplicity is unbounded. This effectively allows multiple requests within a single message up to the maximum size limitation of an InterAct message (100,000 bytes) It is however recommended only include one request per message.

High Level Account Report Request (camt.060)

camt.060

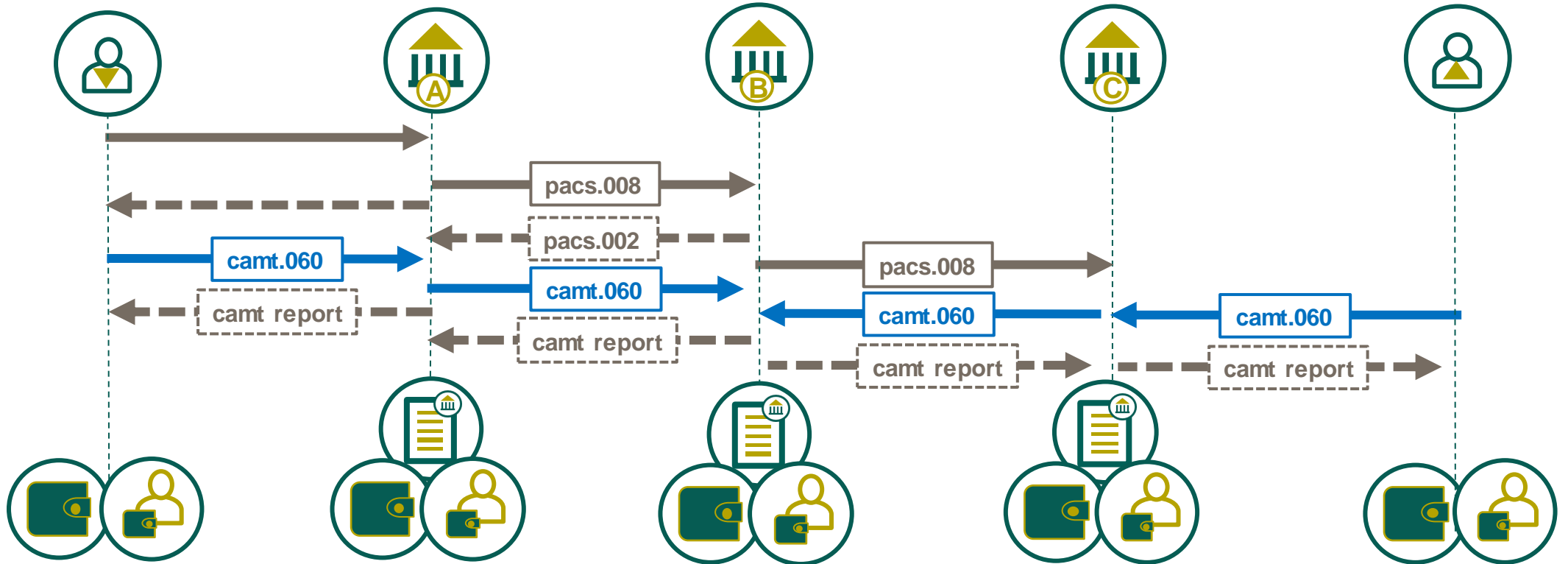

Role of the Creditor Agent and Creditor in the payment changes by description in the Bank to Customer Report Request message to Account Servicer and Account Owner. Whereby the report request is sent by the Account Owner or authorised party to the Account Servicer. This message is used to request a report/s of the entries on an account, and/or to provide the owner with balance information on the account at a given point in time.



Group Header



camt.060 Account Report Request - Message Identification

Min 1 – Max 1

Each ISO 20022 cash management reporting message has a **Message Identification** element, located in the Group Header. This **35 character** identifier is a point to point reference used to unambiguously identify the message.



For Cash Management (camt) messages the **Message Identification** has no exact equivalent in the legacy MT Customer Statement message. However the *Transaction Reference Number* (Field 20) could be considered a similar comparison.

Group Header ➤ Message Identification

camt.060 Account Report Request – Creation DateTime

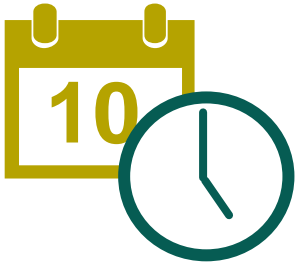

CBPR+ usage guidelines mandate the time zone that the time represents as an offset against Universal Time Coordinated (UTC):

Local time with UTC offset `YYYY-MM-DDThh:mm:ss.sss+/-hh:mm`

- For example: `2002-10-10T12:00:00-05:00` (noon/midday on 10 October 2002, Central Daylight Savings Time as well as Eastern Standard Time in the U.S.)



All CBPR+ time elements need offset against UTC. Milliseconds are optional.

Group Header ▶ Creation Date Time

camt.060 Account Report Request – Message Sender

Min 0 – Max 1

The Account Report Request **Message Sender** nested element provides details of the party that is sending the request.

This element **should only** be used to identify the *Message Sender* when different from the account owner.



Where **Message Sender** is used, a choice of nested **Party** or **Agent** may be used to identify the Sender.

Party:

- **Name** Min 0 – Max 1
- **Postal Address** Min 0 – Max 1
- **Identification** Min 0 – Max 1
- **Country of Residency** Min 0 – Max 1

Agent:



[Take me to the Agent identification](#)

Group Header ▶ Message Sender ⊗

▶ Party

▶ Agent

Reporting Request



camt.060 Account Report Request – Reporting Request

Min 1 – Max *

The Account Reporting Request **Reporting Request** nested element capture the detail related the request.



Many **Account Servicing Institutions** service their **Account Owner** customers through statics account configuration/s. Whereby a variety of reports can be generated on either a time or event bases routine.

The **Reporting Request** may be used as either an alterative to a static configuration or to request ad hoc reports (whether that be an additional report to the statics configuration or to resend reports previous reported).

Reporting Request ▶

camt.060 Account Reporting Request - Identification

Min 1 – Max 1

The Account Reporting Request message **Identification** provides a mandatory element to identify the Request



Unique reference assigned by the account owner (or Message Sender on behalf of the account owner) to unambiguously identify the account statement. Directly comparable with the *Transaction Reference Number* (Field 20) of the legacy MT request message.

camt.060 Account Reporting Request – Requested Message Name Identification

Min 1 – Max 1

The Account Reporting Request message **Requested Message Name Identification** provides a mandatory element to identify the name of the report being request.



This element specifies which type of report is begin requested. The report is represented by its full name.

For example:

camt.052.001.08 or

camt.053.001.08 or

camt.054.001.08

Reporting Request 

Requested Message Name Identification

camt.060 Account Reporting Request – Account

Min 0 – Max 1

The Account Reporting Request message **Account** provides nested elements to identify the account for which the request relates to. A number of elements are nested beneath **Account**, of which the **Identification** element is mandatory.

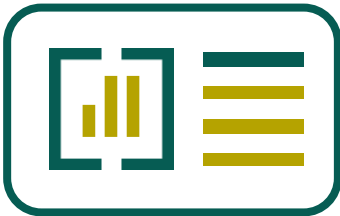

Min 1 – Max 1

a unique **Identification** for the account, between the Account Servicer and Account Owner. The element is further nested by choice of **IBAN** or **Other** to capture the account.

camt.060 Account Reporting Request – Account (continued)

The Account Reporting Request message **Account** ^{Min 1 – Max 1} also provides an number of optional nested element to identify the account for which the request relates to. ^{Min 0 – Max 1}

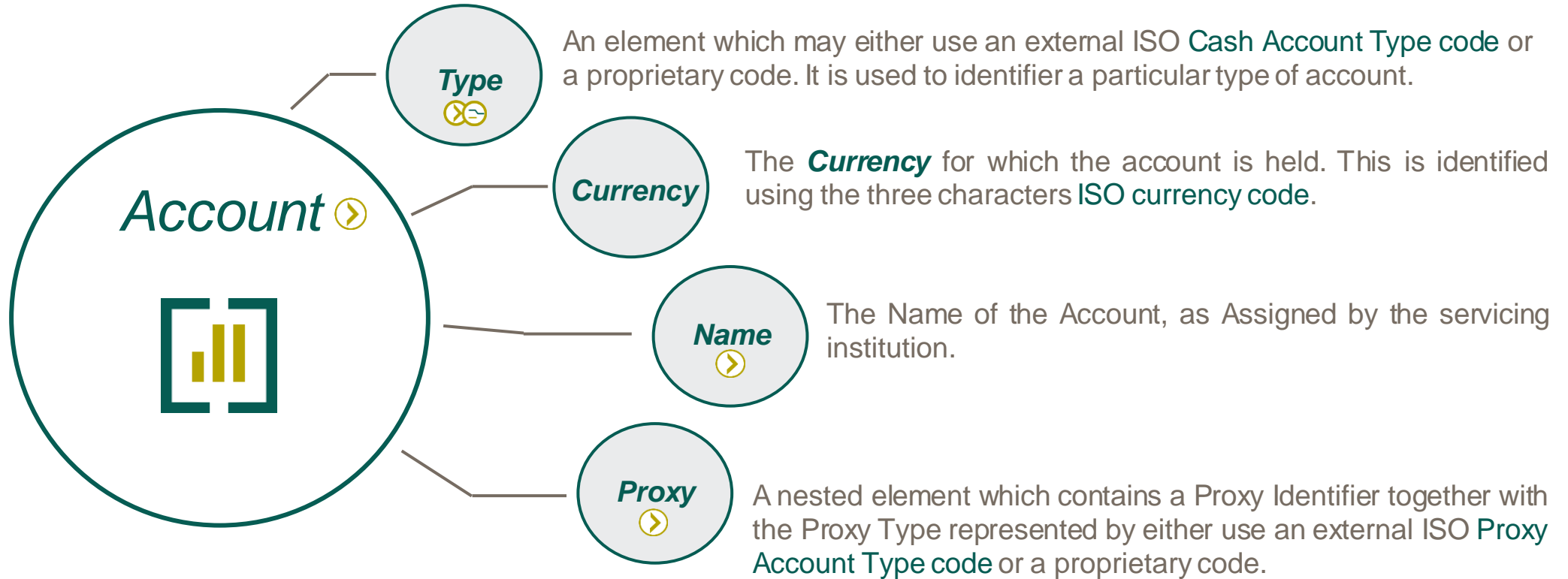

camt.060 Account Reporting Request – Account Owner

Min – Max 1

The Account Reporting Request message **Account Owner** identifies the mandatory owner of the account that the Account Report Request relates to.

Where **Account Owner** is used, a choice of nested **Party** or **Agent** may be used to identify the owner.

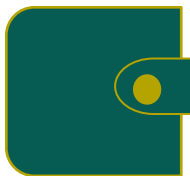

Party:

- **Name** Min 0 – Max 1
- **Postal Address** Min 0 – Max 1
- **Identification** Min 0 – Max 1
- **Country of Residency** Min 0 – Max 1

Agent:



[Take me to the Agent identification](#)



Typically the Account Name (see the previous page) represents the Account Owner's Name in accordance with standard Know Your Customer (KYC). The mandatory Account Owner elements enables more detail to be captured such as an address for a Party or a BIC for an Agent.

camt.060 Account Reporting Request – Account Servicer

Min 0 – Max 1

The Account Reporting Request message **Account Servicer** provides an optional element to capture the Agent who is acting as an Account Servicing Institution. Typically, this would be the same Agent the Account Reporting Request is sent to, who is also identified in the Business Application Header.



Financial Institution Identification:

- ***BICFI***
- ***Clearing System Member Identification***
- ***LEI***
- ***Name***
- ***Postal Address***



[Take me to the Agent identification](#)

camt.060 Account Reporting Request – Report Period

Min 0 – Max 1

The Account Reporting Request message **Report Period** provides the ability to specify the period for which the request relates. Where used this nested element captures a mandatory **From to Date** and an optionally **From to Time** element.

Min 1 – Max 1

Min 0 – Max 1

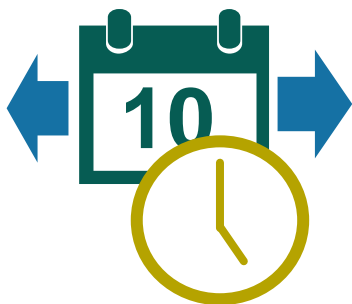

From to Date captures a mandatory **From Date** and an optional **To Date**. It allows the request to specify the date period for which the report is being requested.



All CBPR+ time elements need offset against UTC. Milliseconds are optional.

Reporting Request > Report Period

From to Date

To Date Time

camt.060 Account Reporting Request – Report Sequence

The Account Reporting Request message **Reporting Sequence** ^{Min 0 – Max 1} specifies the choice of identification sequences. This can be used as an alternative to the **Reporting Period** to request a sequence of reports, where the Account Servicing Institution uses this element within the reports they provide. 

Where used the **Reporting Sequence** mandate a choice of nested element:

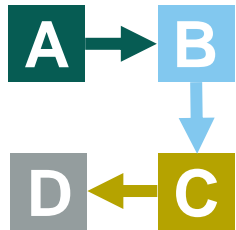

- **From Sequence** identifies the start of a sequence range. ^{Min 1 – Max 1}
- **To Sequence** identifies the end of a sequence range. ^{Min 1 – Max 1}
- **From To Sequence** identifies the start and end of a sequence range. ^{Min 1 – Max *}
- **Equal Sequence** identifies a sequence. ^{Min 1 – Max *}
- **Not Equal Sequence** identifies a sequence to be excluded. ^{Min 1 – Max *}

camt.060 Account Reporting Request – Requested Transaction Type

Min 0 – Max 1

The Account Reporting Request message **Requested Transaction Type** provides the ability to identify the specific type of transactions the request wishes to be reported.

Min 1 – Max 1

Min 1 – Max 1

Where used the **Status** element and **Credit Debit Indicator** elements are mandatory.

- **Status** is a nested element which may either use a choice of external ISO Entry Status code or a proprietary code. It is used to indicate the transaction entry status for which the requested reported should reflect.
- **Credit Debit Indicator** is a choice of embedded code to indicate whether Debit or Credit transaction entries should be reported.

Min 0 – Max 1

An optional **Floor Limit** element may also be used. This element requests a minimum value, for which transaction entries above this value should be reported.

Where used the **Amount** and **Credit Debit Indicator** elements are mandatory.

As a request for specific transaction type/s to be reported, typically this request would relate to a camt.052 Bank to Customer Account Report where the specified balance information is an intraday report. The use of the camt.060 Account Reporting Request and the ability to specify specific reporting requirements in the request is dependent on the Account Servicing Institution and should bilaterally agreed by Account Owner with them.

Reporting Request  Requested Transaction Ty



camt.060 Account Reporting Request – Request Balance Type

The Account Reporting Request message **Requested Balance Type** provides the ability to identify the specific type of balances the request wishes to be reported.

Min 0 – Max *



Min 1 – Max 1

Where used a choice of balance **Code** is mandatory which may either use a choice of external ISO Balance Type code or a proprietary code.

Min 0 – Max 1

An optional **Sub Type** element may also be used which a choice of external ISO Balance Sub Type code or a proprietary code.



As a request for specific balance type/s (or sub balance type/s) to be reported, typically this request would relate to a camt.052 Bank to Customer Account Report where the specified balance information is an intraday report. The use of the camt.060 Account Reporting Request and the ability to specify specific reporting requirements in the request is dependent on the Account Servicing Institution and should be bilaterally agreed by Account Owner with them.

Index of camt.060 Use Cases

Use case should be considered as a principal example whereby use case may be cross referenced

Financial Institution Account Reporting Request

Use Case c.60.1.1 – High Level Financial Institution daily Account Reporting Request

Use Case c.60.1.2 – Financial Institution interim Account Reporting Request

High Level Financial Institution daily Account Reporting Request

Use Case c.60.1.1

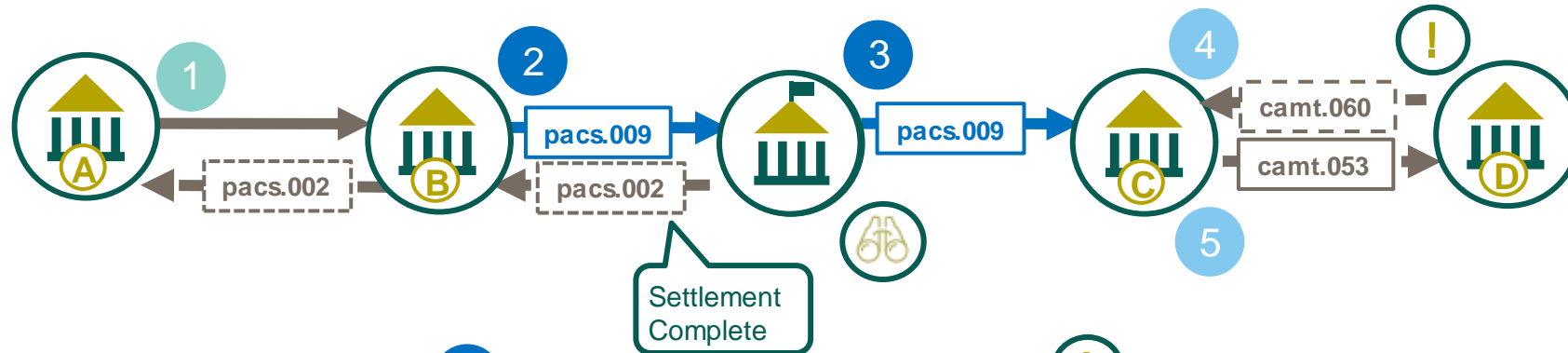

1 Debtor initiates a payment instruction to the Debtor Agent

2 Agent B processes the payment on Agent C, via the Payment Market Infrastructure.

3 Payment Market Infrastructure, settles the payment between Agent B and Agent C as direct participants of the Market Infrastructure, and provides a settlement confirmation to Agent B

4 Agent C credits the account of the Creditor (Agent D)

! Agent D requests a daily statement using a camt.060 (not having an automatic statement produced by their account servicing institution)

5 Agent C produces a customer statement (camt.053) following the request from Agent D



High Level Financial Institution interim Account Reporting Request

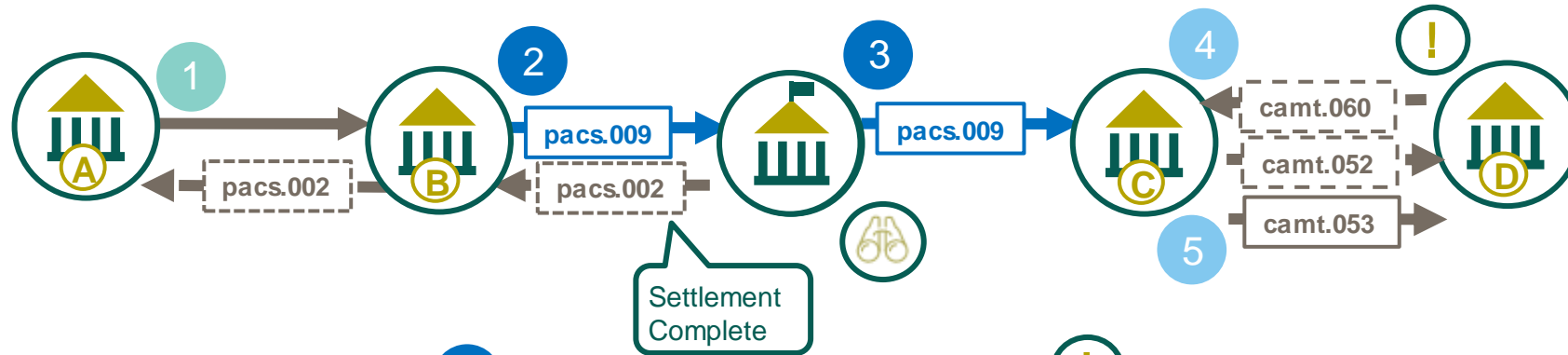

1 Debtor initiates a payment instruction to the Debtor Agent

2 Agent B processes the payment on Agent C, via the Payment Market Infrastructure.

3 Payment Market Infrastructure, settles the payment between Agent B and Agent C as direct participants of the Market Infrastructure, and provides a settlement confirmation to Agent B

4 Agent C credits the account of the Creditor (Agent D)

! Agent D requests an interim statement using a camt.060 (not having an automatic interim statement produced by their account servicing institution)

5 Agent C produces a customer statement (camt.052) following the request from Agent D



Cash Management Exception & Investigation (camt) messages



Exceptions and Investigations - Messages index



[camt.029 – Resolution of Investigation](#)

[camt.055 – Customer Payment Cancellation Request](#)

[camt.056 – FI to FI Payment Cancellation Request](#)

camt.029

Resolution of Investigation



camt.029 Resolution of Investigation

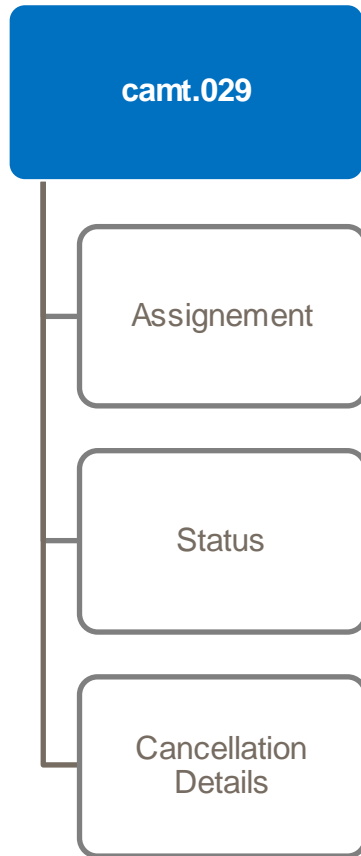

The Resolution of Investigation message is sent by an Agent to respond to the Cancellation Request, either directly or serially through other agents.

The message is used to provide:

- final outcome of the case, whether positive or negative, or
- an interim update prior to the final outcome.



Following a positive acceptance of the Cancellation request. The appropriate payment message (pacs.002 or pacs.004) is used to reject or return a previously received payment.

High Level (Serial) Resolution of Investigation (camt.029)

camt.029

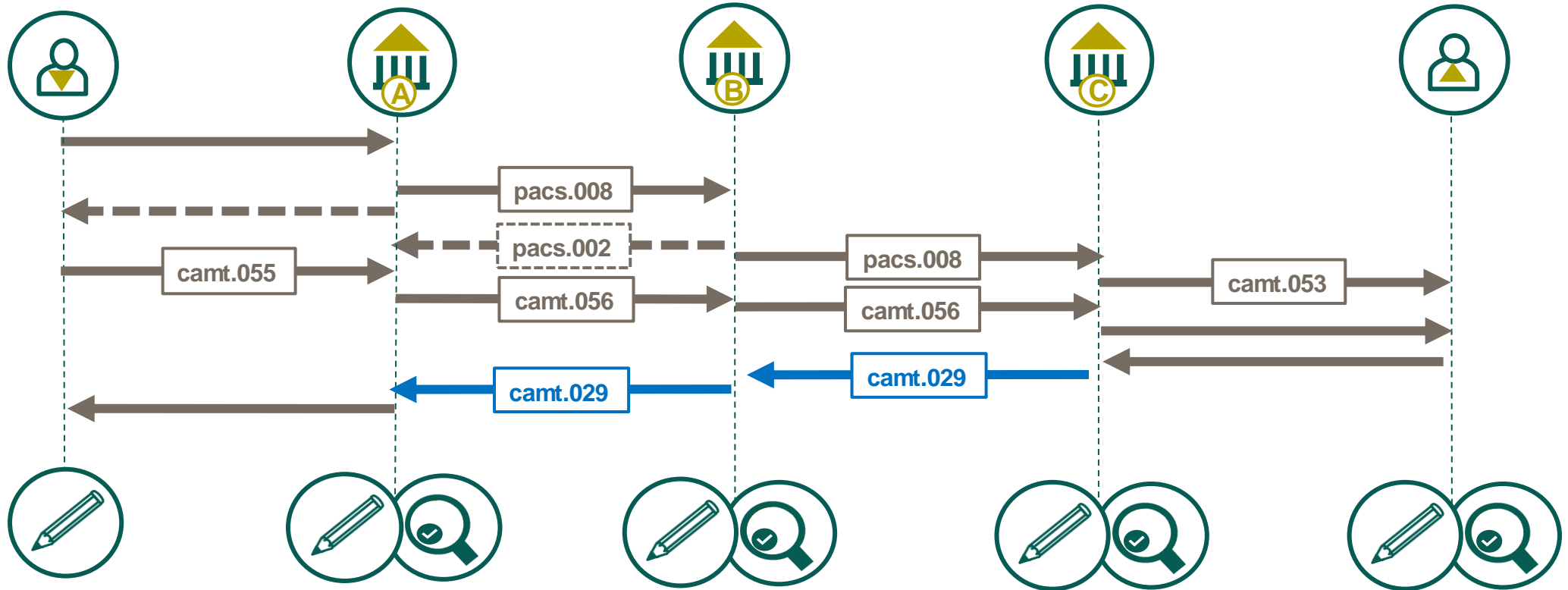

The Resolution of Investigation message is sent by a case assigner to a case assignee. This message is used to provide a response to the cancellation request (interim or final). Following an accepted Cancellation request the return of any payment previous settled is necessary to trigger reversing account postings.

High Level (Direct) Resolution of Investigation (camt.029)

camt.029

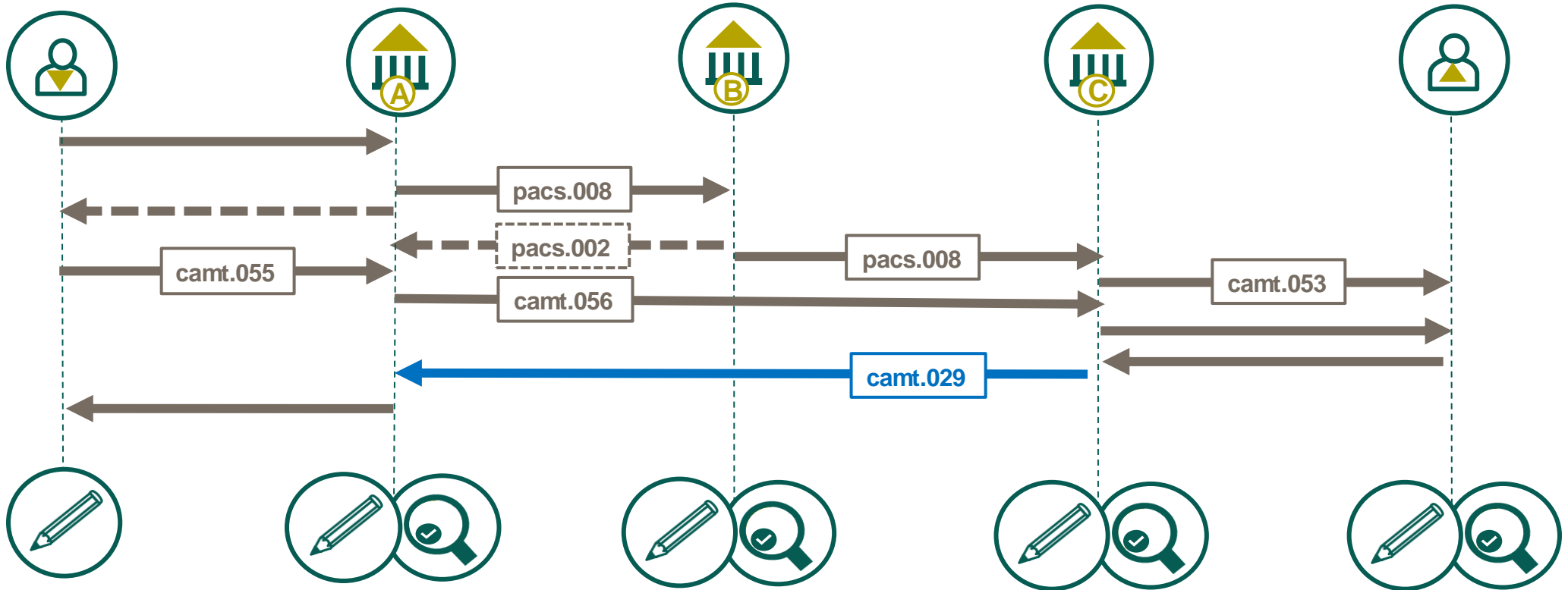

The Resolution of Investigation message is sent by a case assigner to a case assignee. This message is used to provide a response to the cancellation request (interim or final). Following an accepted Cancellation request the return of any payment previous settled is necessary to trigger reversing account postings.

camt.029 Resolution of Investigation – High Level Overview

The camt.056 Payment Cancellation Request and camt.029 Resolution of Investigation messages have a number of identification elements, of which some are used for cross referencing. The below provides a high level overview.

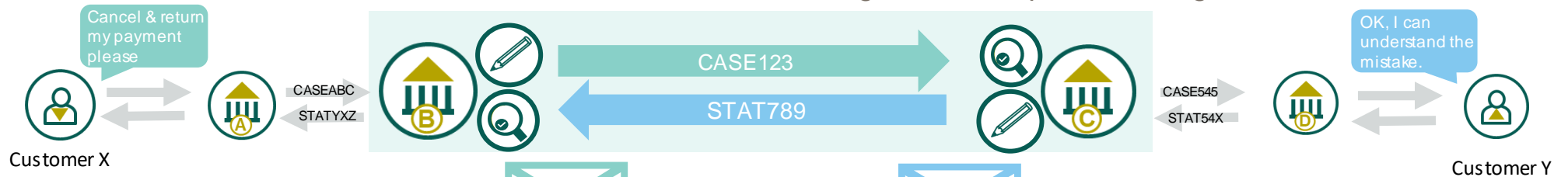

Camt.056 Payment Cancellation Request

ISO

element	description	example
Assigner	Sender of the camt.056	Agent B
Assignee	Receiver of the camt.056	Agent C
Assignment Identification	Unique Id generated by the assigner to identify the Payment Cancellation Request message	CASE123/1
Cancellation identification	Optional Cancellation Id of the Agent sending (assigner) the Payment Cancellation Request message.	CASE123
Case Identification	Case Id of the Agent sending (assigner) the Payment Cancellation Request message.	CASE123
Case Creator	Party w ho created the original cancellation request (w hich may be another Agent other than the current Assigner.	Agent A
Cancellation Reason... Originator	Party w ho provide the original Payment Cancellation Request (w hich may be another Party other than the current Assigner.	Customer X

camt.029 Resolution of Investigation

element	description	example
Assigner	Sender of the camt.029	Agent C
Assignee	Receiver of the camt.029	Agent B
Assignment Identification	Unique Id generated by the assigner to identify the Resolution of Investigation message	STAT789/1
Cancellation Status Identification	Case Reference of the Agent sending (assigner) the Resolution of Investigation message.	STAT789
Resolved (Original) Case Identification	Case Id of the original case the Resolution of Investigation is responding to.	CASE123
Case Creator	Party w ho created the original cancellation request (w hich is the same original case creator in the Payment Cancellation Request)	Agent A
Cancellation Status... Originator	Party w ho provide the original Cancellation response (w hich may be another Party other than the current Assigner.	Customer Y



Assignment



camt.029 Resolution of Investigation - Identification

Min 1 – Max 1

The Payment Cancellation Request message **Identification** provides a mandatory element to identify the Request



Unique reference assigned by the assigner to unambiguously identify the Cancellation request.

For Exceptions and Investigations messages the Identification has no exact equivalent in the legacy MT Exceptions and Investigations message. However, the Transaction Reference Number (Field 20) could be considered a similar comparison.

Directly comparable with the *Transaction Reference Number* (Field 20) of the legacy MT statement message.

camt.029 Resolution of Investigation - Assigner and Assignee

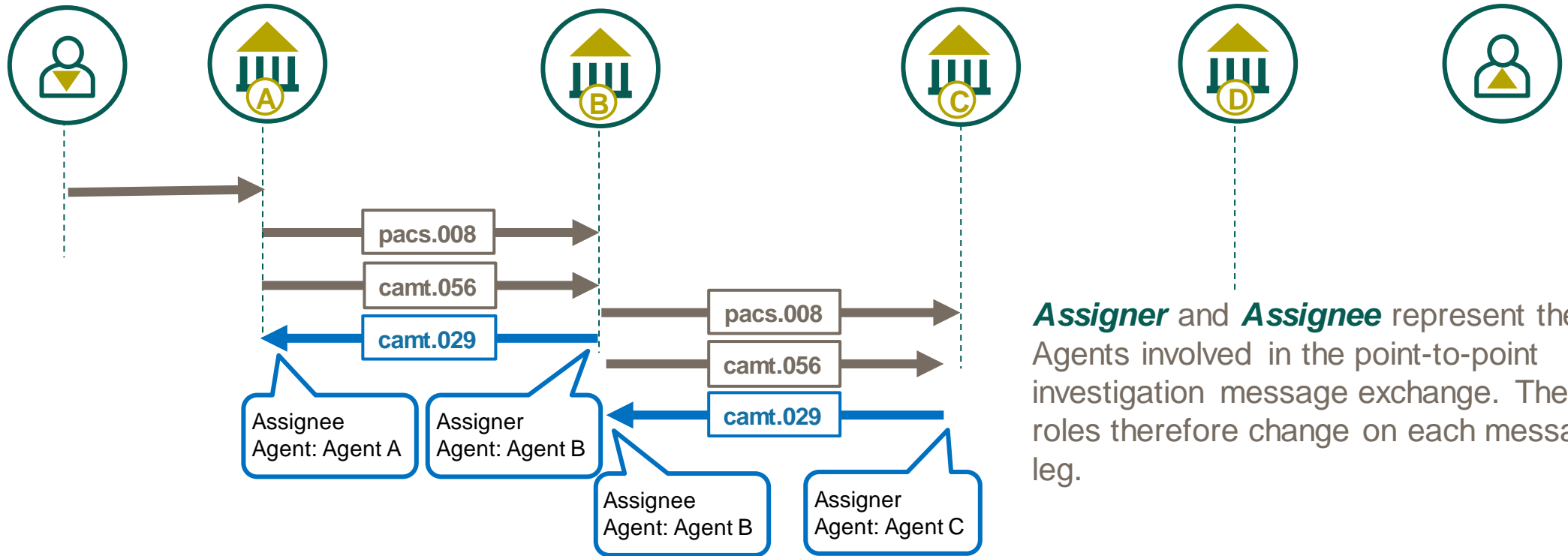

Assigner and **Assignee** represent the Agents involved in the point-to-point investigation message exchange. These roles therefore change on each message leg.

Assignment

Assigner

Assignee



camt.029 Resolution of Investigation – Creation DateTime

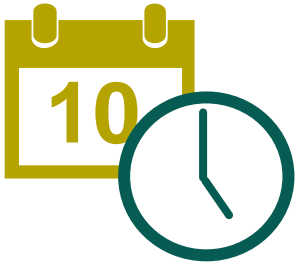

CBPR+ usage guidelines mandate the time zone that the time represents as an offset against Universal Time Coordinated (UTC):

Local time with UTC offset `YYYY-MM-DDThh:mm:ss.sss+/-hh:mm`

- For example: `2002-10-10T12:00:00-05:00` (noon/midday on 10 October 2002, Central Daylight Savings Time as well as Eastern Standard Time in the U.S.)



All CBPR+ time elements need offset against UTC. Milliseconds are optional.

Status



camt.029 Resolution of Investigation - Confirmation

Min 1 – Max 1

The Resolution of Investigation **Confirmation** provides a mandatory element to specify the status of the Payment Cancellation Request's investigation.

The **Confirmation** element includes a choice of three embedded confirmation codes:

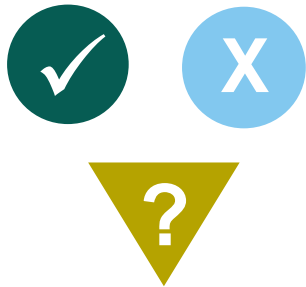

- **CNCL** – The payment has been cancelled as requested. This status concludes the investigation, whereby a Payment Return may follow if funds need to be returned.
- **PDCR** – The Investigation of the Payment Cancellation Request is pending i.e. is under ongoing investigation to provide a final status confirmation. An additional **Cancellation Status Reason Information** should be provided to further clarify the current status. For example, a Status Reason code RQDA can be used to indicate debit authority has been requested from the Creditor.
- **RJCR** – The Payment Cancellation Request is rejected. A status concluding the investigation which must include additional **Cancellation Status Reason Information** to provide an explanation as to why the request was rejected.

Cancellation Details



camt.029 Resolution of Investigation – Transaction Information and Status

Min 1 – Max 1

The Resolution of Investigation **Transaction Information and Status** is a mandatory nested element to capture information related to the original payment and to provide further information on the status reason Payment Cancellation Request's investigation.



As part of this nested element, information is captured to reference; the case the investigation is attempting to resolve, various original references related to the original payment and the investigation status information.

camt.029 Resolution of Investigation – Transaction Information and Status

Min 1 – Max 1

The Resolution of Investigation message **Cancellation Status Identification** provides a mandatory element to identify the status update.



Unique reference assigned by the resolution assigner to unambiguously identify the Cancellation status.

For Exceptions and Investigations messages the *Cancellation Status Identification* can be considered an equivalent in the legacy MT Directly comparable with the *Transaction Reference Number* (Field 20) of the legacy MT statement message.

Cancellation Detail > Transaction Information and Status >

> Cancellation Identification

camt.029 Resolution of Investigation – Resolved Case

Min 1 – Max 1

The Resolution of Investigation message **Resolved Case** provides a mandatory nested element to identify the Resolved Case **Identification** and the **Creator** of the case.

Min 1 – Max 1

The **Identification** element captures the unique case reference assigned by the Payment Cancellation Request Assigner to unambiguously identify the Cancellation investigation case being resolved.

For Exceptions and Investigations messages this *Case Identification* can be considered an equivalent of the *Related Reference* (Field 21) of the legacy MT Answer message.

Min 1 – Max 1

The **Creator** element captures the party who created the Payment Cancellation Request investigation (see [camt.056 Case Creator](#)).

This mandatory party can represent as either an **Agent** i.e., the Bank who created the case or as a **Party** i.e., the customer (for example the Debtor) who created the request. This element has no equivalent in the legacy MT Request for Cancellation message.

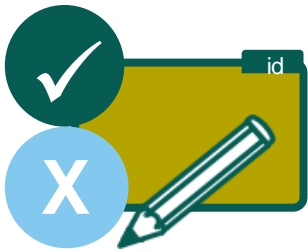

Cancellation Detail > Transaction Information and Status >

> Resolved Case

camt.029 Resolution of Investigation – Original Group Information

Min 1 – Max 1

The Resolution of Investigation uses elements in the **Original Group Information** to capture the message identifier and message name of the underlying payment for which the investigation relates to. The mandatory **Original Message Identification** contains the point-to-point reference from this payment, and the mandatory **Original Message Name Identification** contains the message name of the underlying payment. Optionally the **Original Creation Date Time** can also be captured.

For example:

Original Message Name Identification “pacs.008.001.08” confirms the investigation relates to a pacs.008 Financial Institution to Financial Institution Customer Credit Transfer. Where as “pacs.009.001.08” confirms the investigation relates to a pacs.009 Financial Institution Credit Transfer.

 Note: the xx in the CBPR+ Usage Guideline represents the message version of the message received for example pacs.008.001.08

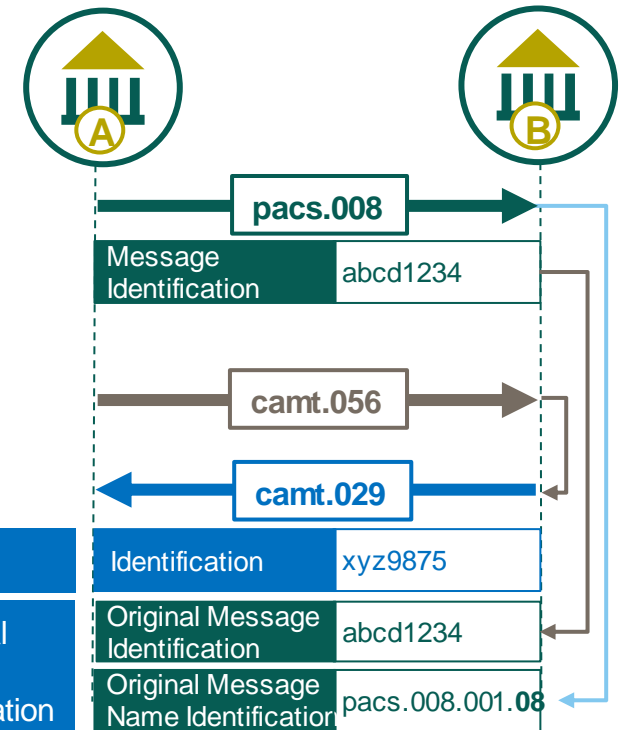

Assignment		Identification	xyz9875
Cancellation Details	Original Group Information	Original Message Identification	abcd1234
		Original Message Name Identification	pacs.008.001.08



camt.029 Resolution of Investigation – Original elements

The Resolution of Investigation also uses a number of other **Original** elements in the **Transaction Information** to capture information from the underlying payment that the Cancellation request relates to.

The Original elements enables the **Assignee** to identify the Payment which is being request to be cancelled. The following element (in addition to *Original Message identification* and *Original Message Name Identification* described on the previous page) are mandated:

Original UETR

Min 1 – Max 1



The following element (in addition to *Original Message identification* and *Original Message Name Identification* described on the previous page) are optional:

Original End to End Identification

Min 0 – Max 1

Original Instruction Identification

Min 0 – Max 1

Original Transaction Identification

Min 0 – Max 1

Original Clearing System Reference

Min 0 – Max 1

Cancellation Details	Transaction Information and Status
Original Group Information	
Original Instruction Identification	
Original End to End Identification	
Original Transaction	
Original Clearing System Reference	
Original UETR	

camt.029 Resolution of Investigation – Cancellation Status Reason Information

Min 0 – Max 1

The Resolution of Investigation **Cancellation Status Reason Information** nested element captures the information related to the status reason of the Cancellation Resolution.

Min 0 – Max 1



the **Originator** element helps identify the party who provided the Cancellation status. This party would have been included in the underlying payment and is also included the pacs.004 *Return Chain*.

Min 0 – Max 1



the **Reason** for the Cancellation status, which is mandatory where the Resolution Status is RJCR, is represented by an embedded CBPR+ Cancellation **Code** choice (↔)

Min 0 – Max 1

the **Additional Information** element may also be included to provide further details on the Cancellation reason.



Note where Reason code NARR is used additional information must be provided to describe the reason for the Cancellation request.



In the event that an **indemnity agreement** is need to be established, **INDM** should be indicated at the beginning of the Additional Information element. Any subsequent additional information may then be included.

Cancellation Details ▶ Transaction Information and Status ▼

▶ Original Group Information ▼

▶ Originator

⊗ Reason

Additional Information



camt.029 Resolution of Investigation – Cancellation Status Reason codes

Min 0 – Max 1

The Resolution of Investigation **Reason** element is optional. CBPR+ have defined a sub-set of the ISO externalised code list which is represented as an embedded **Code** choice. This list ensures interoperability with the legacy FIN request for Cancellation message, which can be broadened after the coexistence period.

Code	Name	Definition	Use Case
AC04	Closed Account Number	Account number specified has been closed on the receiver's books.	Complimenting a Reject Status. Payment Cancellation Request can not be accepted as the Creditor has since closed their account.
AGNT	Agent Decision	Reported when the cancellation cannot be accepted because of an agent refuses to cancel.	Complimenting a Reject Status. Payment Cancellation Request can not be accepted as an Agent in the payment transaction does not accept the request.
AM04	Insufficient Funds	Amount of funds available to cover specified message amount is insufficient.	Complimenting a Reject Status. Payment Cancellation Request can not be accepted as the Creditor has insufficient funds to perform the return payment.
ARDT	Already Returned	Cancellation not accepted as the transaction has already been returned.	Complimenting a Reject Status. Payment Cancellation Request can not be accepted as the payment has already return payment.
CUST	Customer Decision	Reported when the cancellation cannot be accepted because of a customer decision (Creditor).	Complimenting a Reject Status. Payment Cancellation Request can not be accepted as the Creditor does not provide authority to return the payment. i.e. believe the payment was justified.
INDM	Indemnity Request	Indemnity is required before funds can be returned	Complimenting a Pending or Reject Status. Payment Cancellation Request can not be accepted until an indemnity agreement is established.

camt.029 Resolution of Investigation – Cancellation Status Reason codes (continued)

Definitions and High Level Use Cases

LEGL	Legal Decision	Reported when the cancellation cannot be accepted because of regulatory rules.	
NAAR	Narrative	Reason is provided as narrative information in the additional reason information.	Complimenting a Reject or Pending Status to provide further narrative Additional Information .
NOAS	No Answer From Customer	No response from beneficiary (to the cancellation request).	Complimenting a Reject Status. Payment Cancellation Request can not be accepted as the Creditor has not responded to a Debit Authority request to return the payment.
NOOR	No Original Transaction Received	Original transaction (subject to cancellation) never received.	Complimenting a Reject Status. Payment Cancellation Request can not be accepted as it is believed that the original payment was never received for the UETR and references provided.
PTNA	Passed To The Next Agent	Reported when the cancellation request cannot be accepted because the payment instruction has been passed to the next agent.	Complimenting a Pending Status. Payment has been onward processed to the next agent in the transaction. The Payment Cancellation Request has therefore been forward to this Agent, a further resolution message will be sent once this Agent provides a response.
RQDA	Requesting Debit Authority	Reported when authority is required by the Creditor to return the payment.	Complimenting a Pending Status. Payment has been credited to the creditor, Authority to Debit the Creditor and return the payment is being request. A further resolution message will be sent once the Creditor provides a response.

Index of camt.029 Use Cases

Use case should be considered as a principal example whereby use case may be cross referenced

Resolution of Investigation

Use Case c.29.1.1 – High Level Resolution of Investigation (camt.029) of a completed Customer Credit Transfer (pacs.008)

Use Case c.29.1.1.a – High Level Resolution of Investigation (camt.029) of a completed Customer Credit Transfer (pacs.008) using gpi Stop and Recall

Use Case c.29.1.2 – High Level Resolution of Investigation (camt.029) of an incomplete Customer Credit Transfer (pacs.008)

Use Case c.29.1.2.a – High Level Resolution of Investigation (camt.029) of an incomplete Customer Credit Transfer (pacs.008) using gpi Stop and Recall

Use Case c.29.2.1 – High Level Resolution of Investigation (camt.029) of a complete Customer Credit Transfers (pacs.008) settled using the cover method

Use Case c.29.2.2 – High Level Resolution of Investigation (camt.029) of an incomplete Customer Credit Transfers (pacs.008) settled using the cover method

Use Case c.29.2.3 – High Level Resolution of Investigation (camt.029) of a Customer Credit Transfers (pacs.008) where the cover is returned

Use Case c.29.3.1 – High Level Resolution of Investigation (camt.029) of a Financial Institution Credit Transfer (pacs.009)

Use Case c.29.4.1 – High Level Resolution of Investigation (camt.029) of a Financial Institution Credit Transfer advice (pacs.009 adv)

High Level Resolution of Investigation (camt.029) of a complete Customer Credit Transfer (pacs.008)

Use Case c.29.1.1

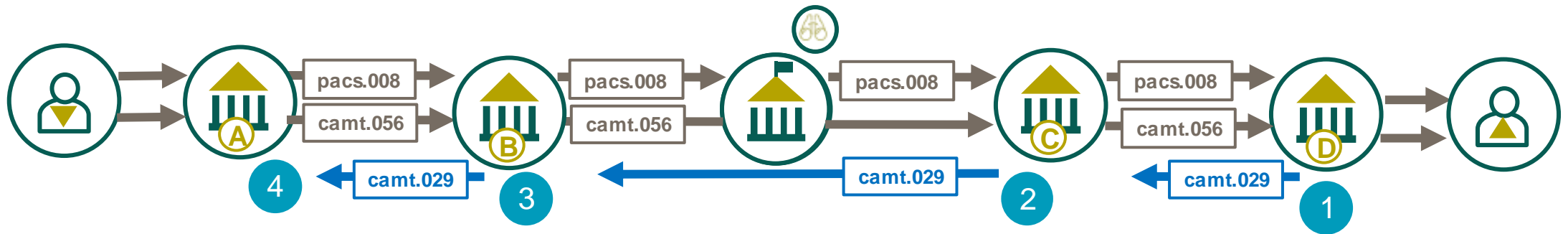

1 Agent D provides a final outcome of the investigation to Agent C using the camt.029.

3 Debtor Agent (B) updates their case history and relays the outcome of the investigation to Agent A using the camt.029

 See use case [p.8.1.1](#) for the original payment, [c.56.1.1](#) for case resolution and [p.4.1.3](#) for an example payment return

2 Debtor Agent (C) updates their case history and relays the outcome of the investigation to Agent B using the camt.029

4 Debtor Agent (A) updates their case history and informs the customer of the outcome of the investigation.



High Level Resolution of Investigation (camt.029) of a complete Customer Credit Transfer (pacs.008) using gpi Stop and Recall

Use Case c.29.1.1.a

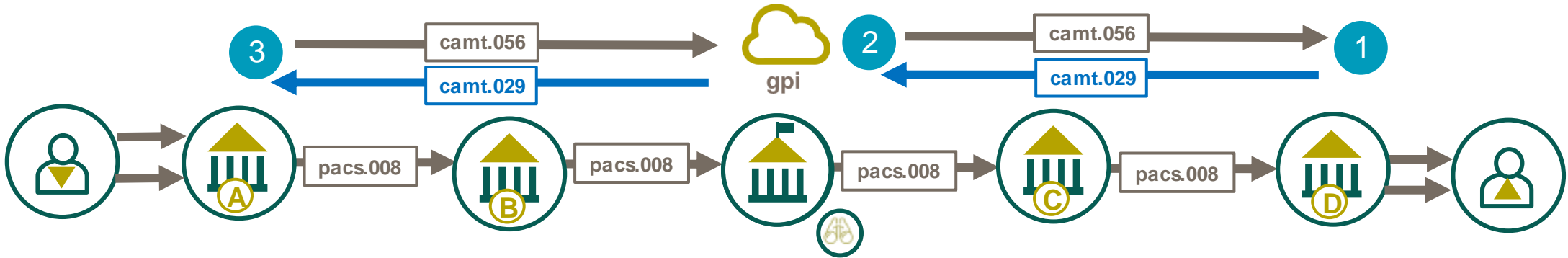

 See use case [p.8.1.1](#) for the original payment, [c.29.1.1](#) for case resolution and [p.4.1.3](#) for an example payment return

1 Agent D provides an update on the investigation to the gpi Tracker using the camt.029.

3 Debtor Agent (A) updates their case history and informs the customer of the outcome of the investigation.

2 gpi Tracker forwards the response to Agent A as the initiator of the original camt.056



High Level Resolution of Investigation (camt.029) of an incomplete Customer Credit Transfer (pacs.008)

Use Case c.29.1.2

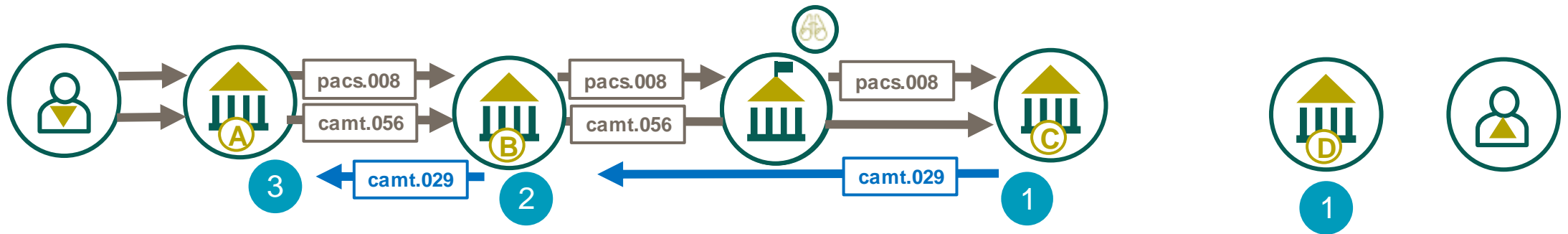

1 Agent C provides a final outcome of the investigation to Agent B using the camt.029

3 Debtor Agent (A) updates their case history and informs the customer of the outcome of the investigation.

 See [use case p.8.1.1](#) for the original payment, c.56.1.2 for case resolution and p.4.1.3. for an example payment return

2 Debtor Agent (B) updates their case history and relays the outcome of the investigation to Agent A using the camt.029



High Level Resolution of Investigation (camt.029) of an incomplete Customer Credit Transfer (pacs.008) using gpi Stop and Recall

Use Case c.29.1.2.a

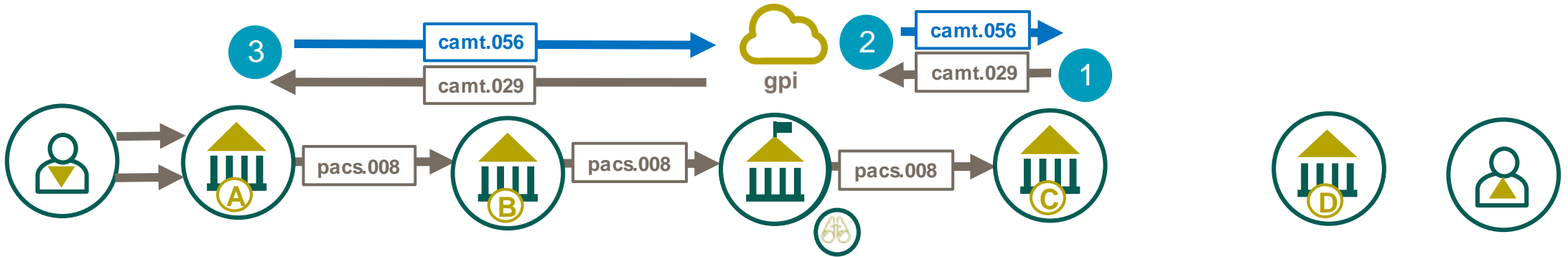

1 Agent C provides an update on the investigation to the gpi Tracker using the camt.029.

3 Debtor Agent (A) updates their case history and informs the customer of the outcome of the investigation.

2 gpi Tracker forwards the response to Agent A as the initiator of the original camt.056



Market Infrastructure will either conform to HVPS+ guidelines or establish their own usage guidelines based on the ISO 20022 standard.

High Level Resolution of Investigation (camt.029) of a complete Customer Credit Transfer (pacs.008) settled using a cover method Use Case c.29.2.1

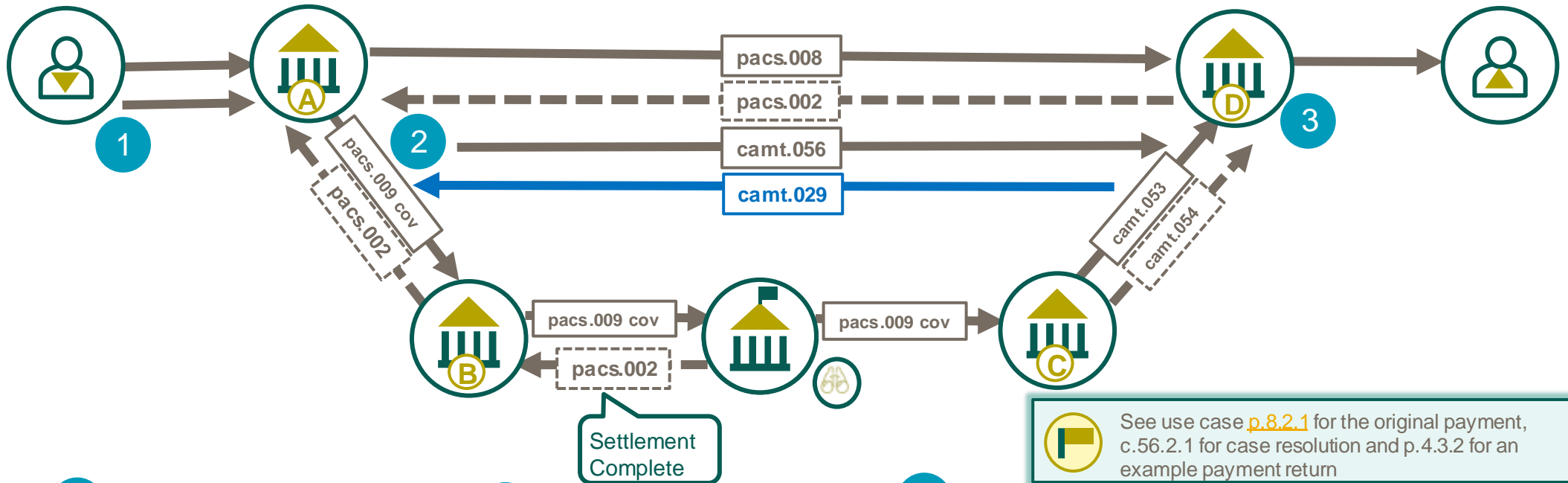

1 Debtor request their bank to recall a previous instructed payment, as the amount was incorrect.

2 Debtor Agent (A) assigns a Cancellation Request to Agent D (assignee) requesting the original pacs.008 is returned, using reason code AM09.

3 Agent D creates an investigation case. Recognising the payment has already been credited to the creditor. They request debit authority, proving the reason specified for the return request and update Agent A. Once the outcome to the debit authorisation is know a final resolution to the investigation can be relayed and any necessary return payment can be initiated.

See use case [p.8.2.1](#) for the original payment, [c.56.2.1](#) for case resolution and [p.4.3.2](#) for an example payment return



High Level Resolution of Investigation (camt.029) of an incomplete Customer Credit Transfer (pacs.008) settled using a cover method.

Use Case c.29.2.2

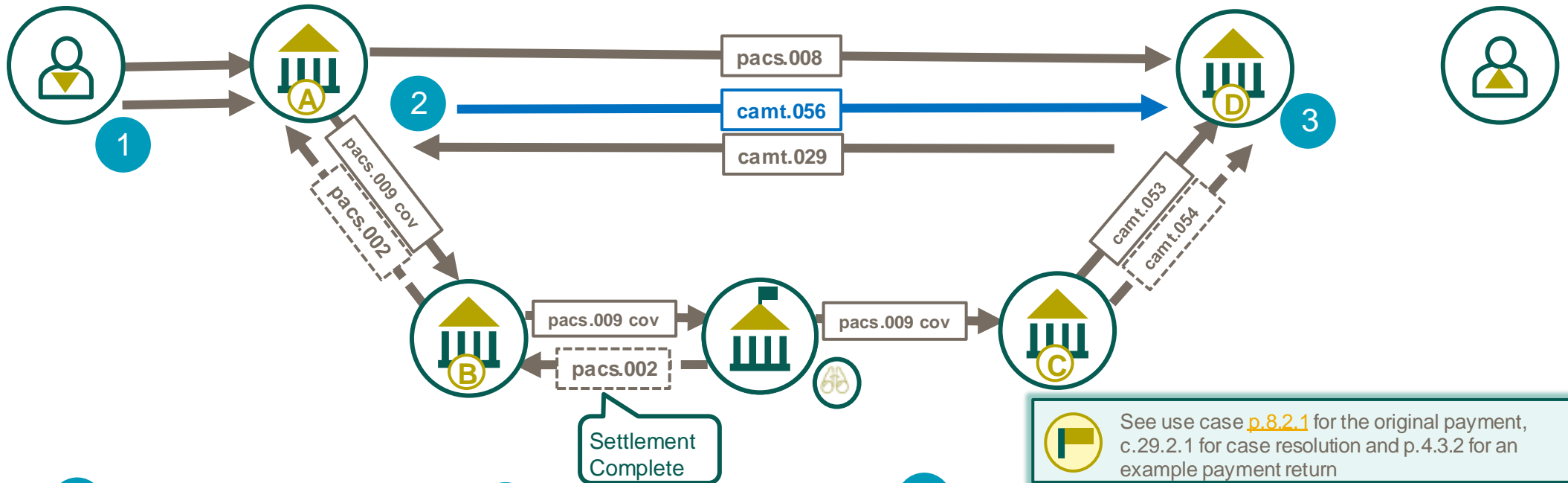

1 Debtor request their bank to recall a previous instructed payment, as the amount was incorrect.

2 Debtor Agent (A) assigns a Cancellation Request to Agent D (assignee) requesting the original pacs.008 is returned, using reason code AM09.

3 Agent D creates an investigation case. Recognising the payment has not been credited to the creditor. They update Agent A that the Cancellation Request is accepted and arrange the necessary return payment once the pacs.009 cov settlement is confirmed by Agent C



High Level Resolution of Investigation (camt.029) of a Customer Credit Transfers (pacs.008) where the cover is returned

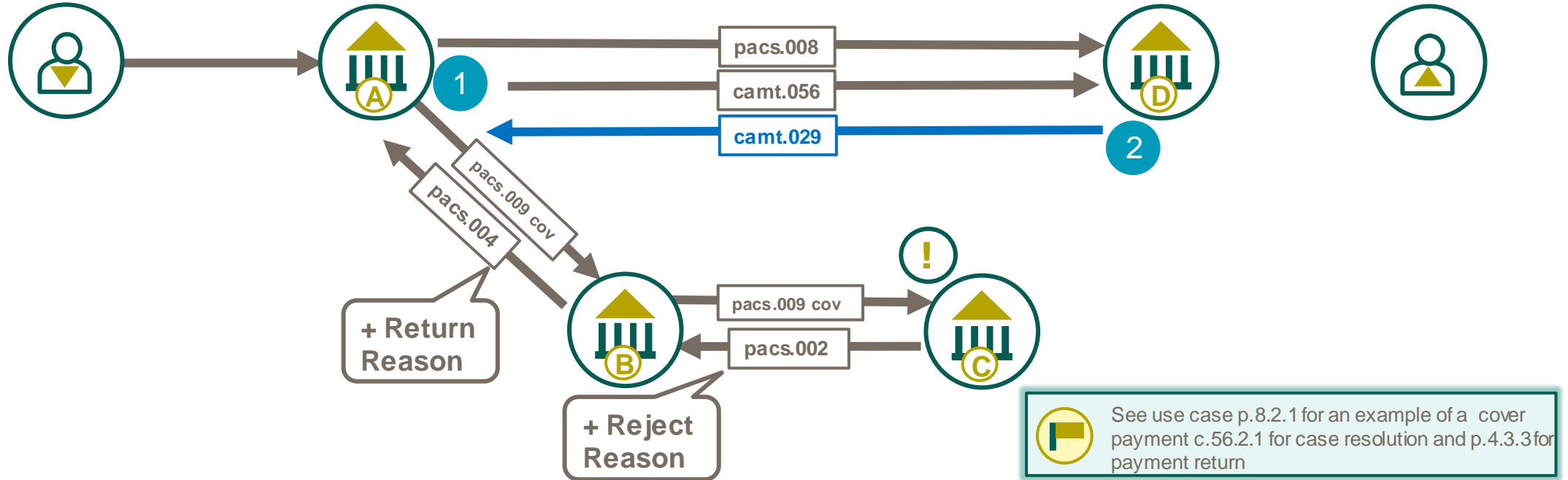

! Agent C receives the payment and recognises the payment can not be completed as requested e.g. the Agent D does not maintain an account with them.

1 Debtor Agent (A) assigns a Cancellation Request to Agent D (assignee) requesting the original pacs.008 is considered null and void, using reason code COVR.

2 Agent D creates an investigation case. Recognising the cover payment will not be received to settle the pacs.008. As the creditor has not been credited in advance of cover settlement, a final resolution to the investigation can be provided. A payment return is not necessary.

High Level Resolution of Investigation (camt.029) of a Financial Institution Credit Transfer (pacs.009)

Use Case c.29.3.1

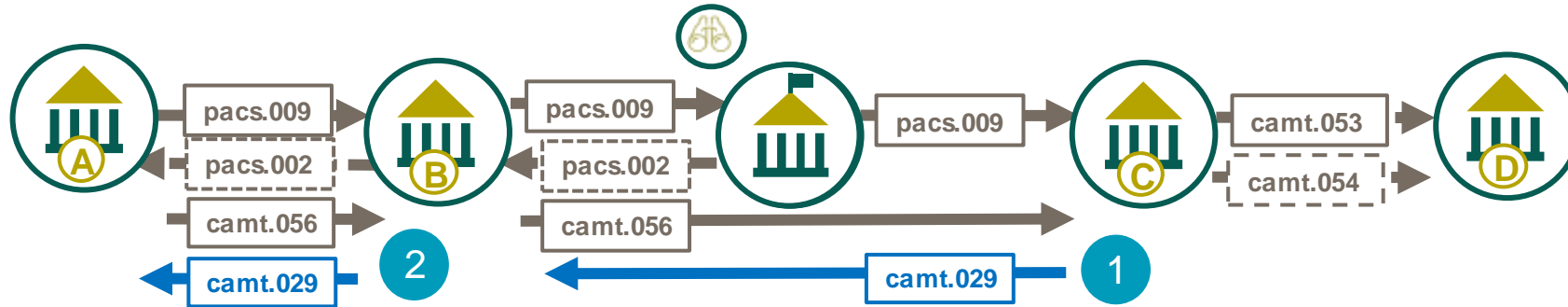

 See use case p.9.1.1 for the cover payment sample c.56.3.1 for case resolution and p.4.2.3 for payment return

1
Agent C provides a final outcome of the investigation to Agent B using the camt.029.

2
Debtor Agent (B) updates their case history and informs the customer (Agent A) of the outcome of the investigation.



High Level Resolution of Investigation (camt.029) of a Financial Institution

Credit Transfer advice (pacs.009 adv)

Use Case c.29.4.1

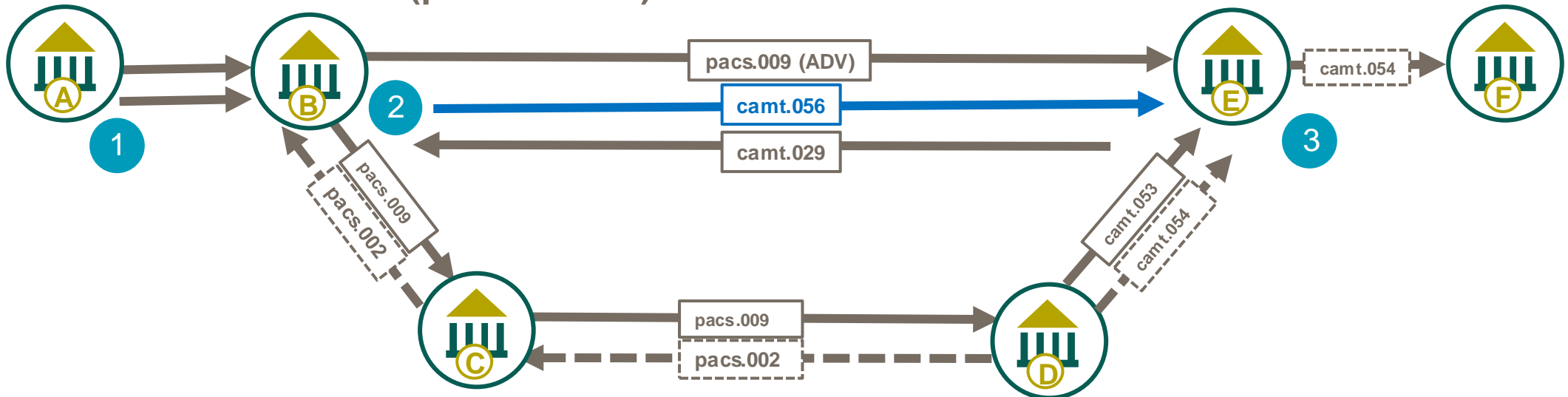

 See use case p.9.1.2 for the cover payment sample c.56.4.1 for case resolution and p.4.2.3 for payment return

1 Debtor request their bank to recall a previous instructed payment, as the amount was incorrect.

2 Debtor Agent (A) assigns a Cancellation Request to Agent E (assignee) requesting the original pacs.008 is returned, using reason code AM09.

3 Agent E creates an investigation case. Recognising the payment has already been credited to the creditor. They request debit authority, proving the reason specified for the return request and update Agent B. Once the outcome to the debit authorisation is know a final resolution to the investigation can be relayed and any necessary return payment can be initiated.

camt.055



Customer Payment Cancellation Request



camt.055 Customer Payment Cancellation Request

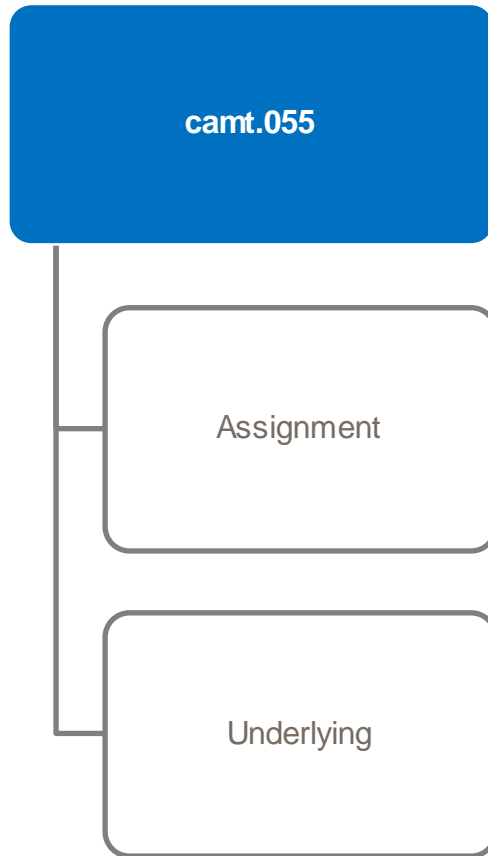

The Customer Payment Cancellation Request message is sent by an Agent to request the Cancellation of a payment initiation request previous sent.

The message is sent either:

- directly to the Agent a previous Payment initiation request was sent to.

High Level Customer Payment Cancellation Request: Payment Initiation “Relay”

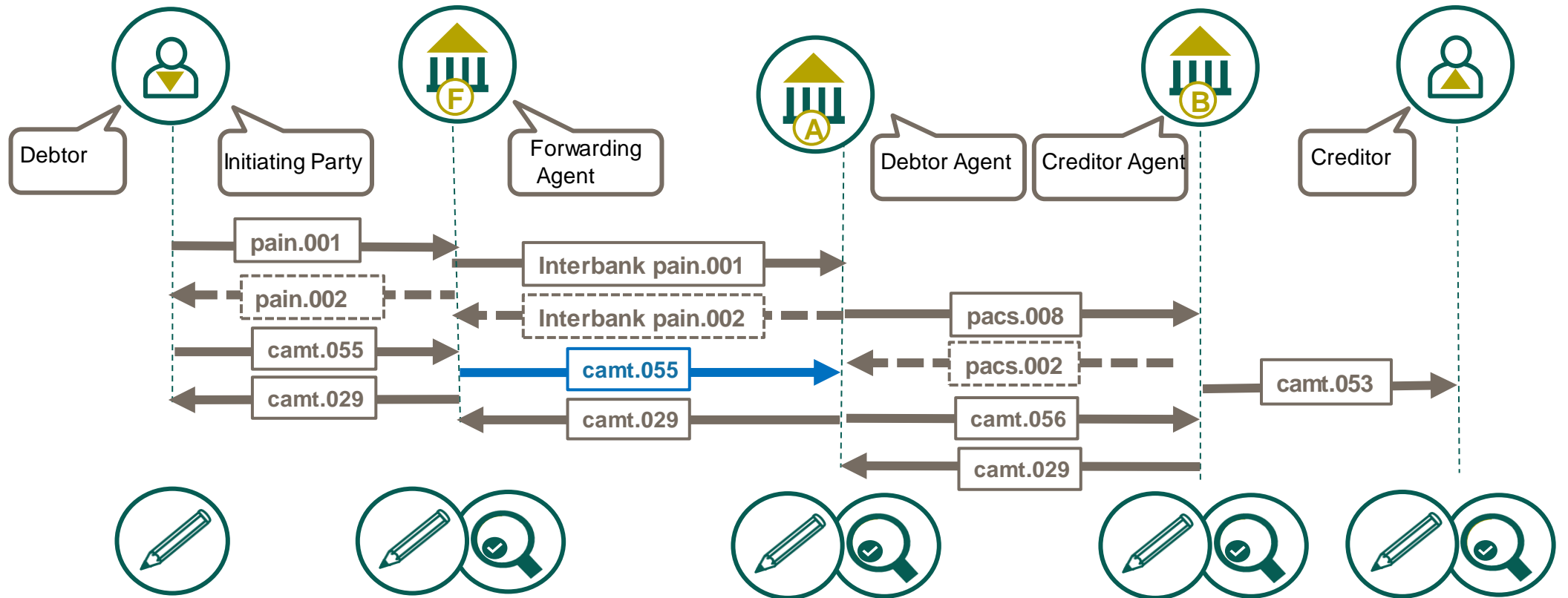

The CustomerPaymentCancellationRequest message is sent by a case creator/case assigner to a case assignee. This message is used to request the cancellation of an original payment instruction (pre or post settlement to the Creditor). The CustomerPaymentCancellationRequest message is issued by the initiating party to request the cancellation of an initiation payment message previously sent.

High Level Customer Payment Cancellation Request : Payment Initiation “Authorised Party Initiation”

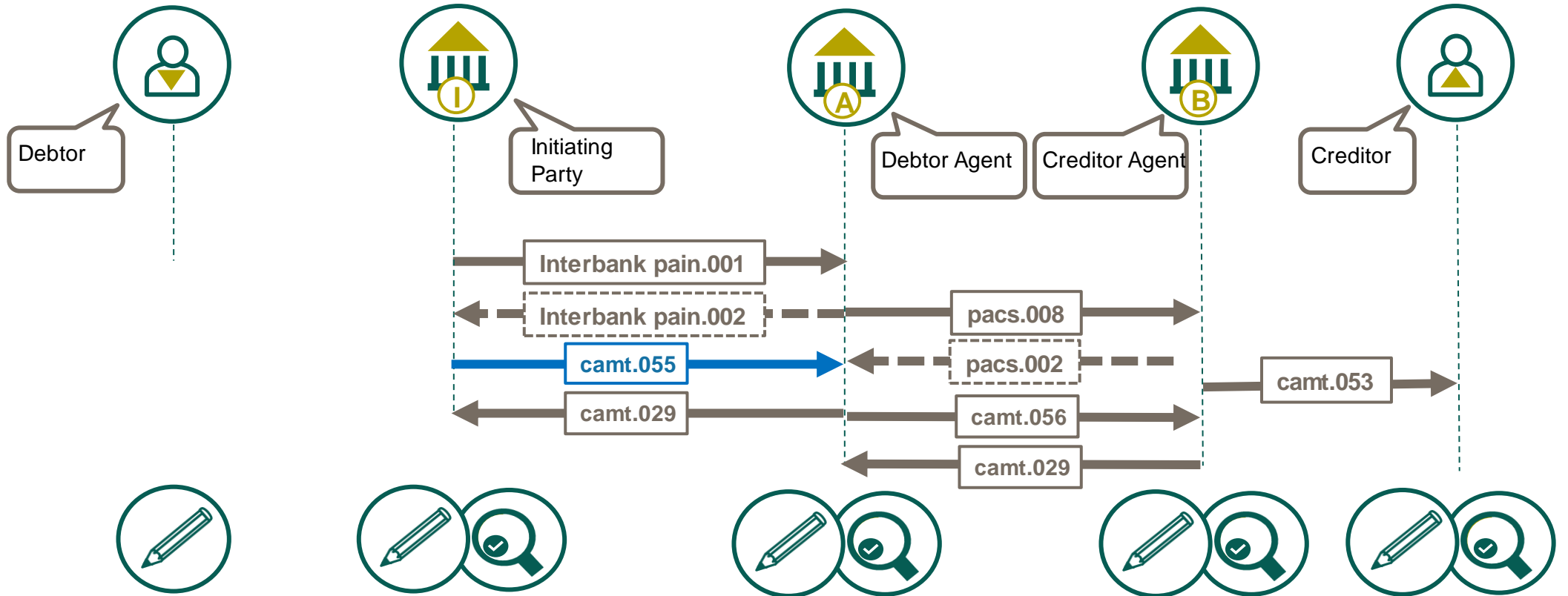

The CustomerPaymentCancellationRequest message is sent by a case creator/case assigner to a case assignee. This message is used to request the cancellation of an original payment instruction (pre or post settlement to the Creditor). The CustomerPaymentCancellationRequest message is issued by the initiating party to request the cancellation of an initiation payment message previously sent.

High Level Customer Payment Cancellation Request : Payment Initiation “FI Payment Initiation”

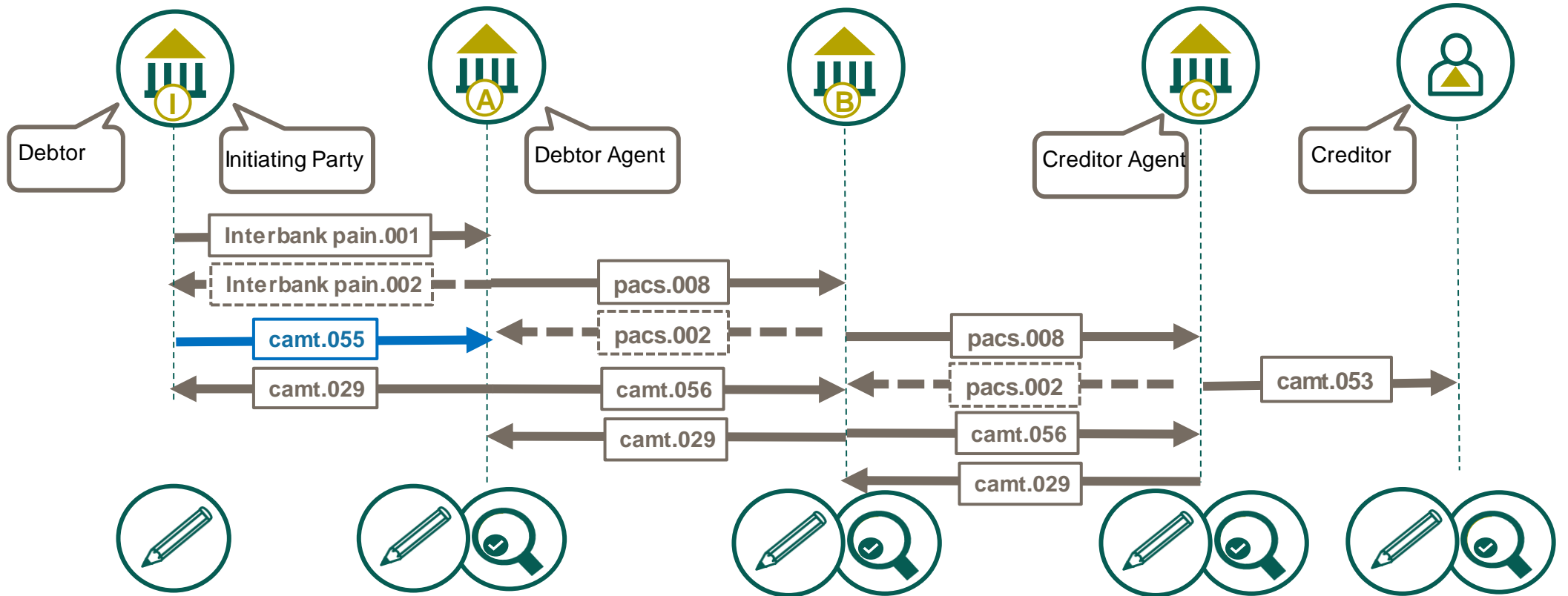

The CustomerPaymentCancellationRequest message is sent by a case creator/case assigner to a case assignee. This message is used to request the cancellation of an original payment instruction (pre or post settlement to the Creditor). The CustomerPaymentCancellationRequest message is issued by the initiating party to request the cancellation of an initiation payment message previously sent.

camt.055 Customer Payment Cancellation Request – High Level Overview

The camt.056 Payment Cancellation Request and camt.029 Resolution of Investigation messages have a number of identification elements, of which some are used for cross referencing. The below provides a high level overview.

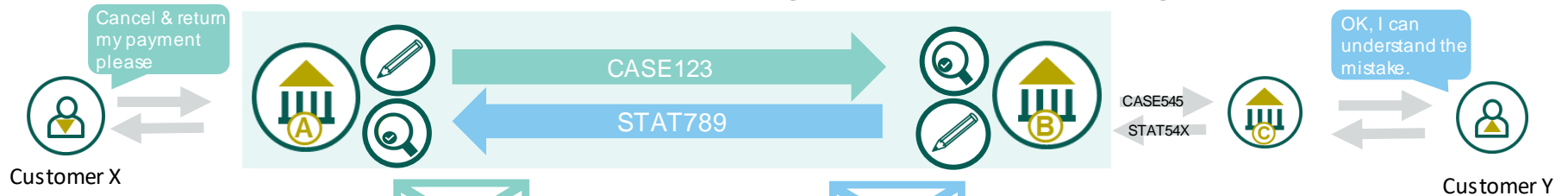

Camt.055 Payment Cancellation Request



camt.029 Resolution of Investigation



element	description	example
Assigner	Sender of the camt.055	Agent A
Assignee	Receiver of the camt.055	Agent B
Assignment Identification	Unique Id generated by the assigner to identify the Payment Cancellation Request message	CASE123/1
Cancellation identification	Optional Cancellation Id of the Agent sending (assigner) the Payment Cancellation Request message.	CASE123
Case Identification	Case Id of the Agent sending (assigner) the Payment Cancellation Request message.	CASE123
Case Creator	Party w ho created the original cancellation request (w hich may be another Agent other than the current Assigner).	Agent A
Cancellation Reason... Originator	Party w ho provide the original Payment Cancellation Request (w hich may be another Party other than the current Assigner).	Customer X



element	description	example
Assigner	Sender of the camt.029	Agent
Assignee	Receiver of the camt.029	Agent A
Assignment Identification	Unique Id generated by the assigner to identify the Resolution of Investigation message	STAT789/1
Cancellation Status Identification	Case Reference of the Agent sending (assigner) the Resolution of Investigation message.	STAT789
Resolved (Original) Case Identification	Case Id of the original case the Resolution of Investigation is responding to.	CASE123
Case Creator	Party w ho created the original cancellation request (w hich is the same original case creator in the Payment Cancellation Request)	Agent A
Cancellation Status... Originator	Party w ho provide the original Cancellation response (w hich may be another Party other than the current Assigner).	Customer Y



Assignment



camt.055 Customer Payment Cancellation Request - Identification

Min 1 – Max 1

The Payment Cancellation Request message **Identification** provides a mandatory element to identify the Request



Unique reference assigned by the assigner to unambiguously identify the Cancellation request.

For Exceptions and Investigations messages the Identification has no exact equivalent in the legacy MT Exceptions and Investigations message. However, the Transaction Reference Number (Field 20) could be considered a similar comparison.

Directly comparable with the *Transaction Reference Number* (Field 20) of the legacy MT statement message.

Assignment  Identification

camt.055 Customer Payment Cancellation Request - Assigner and Assignee

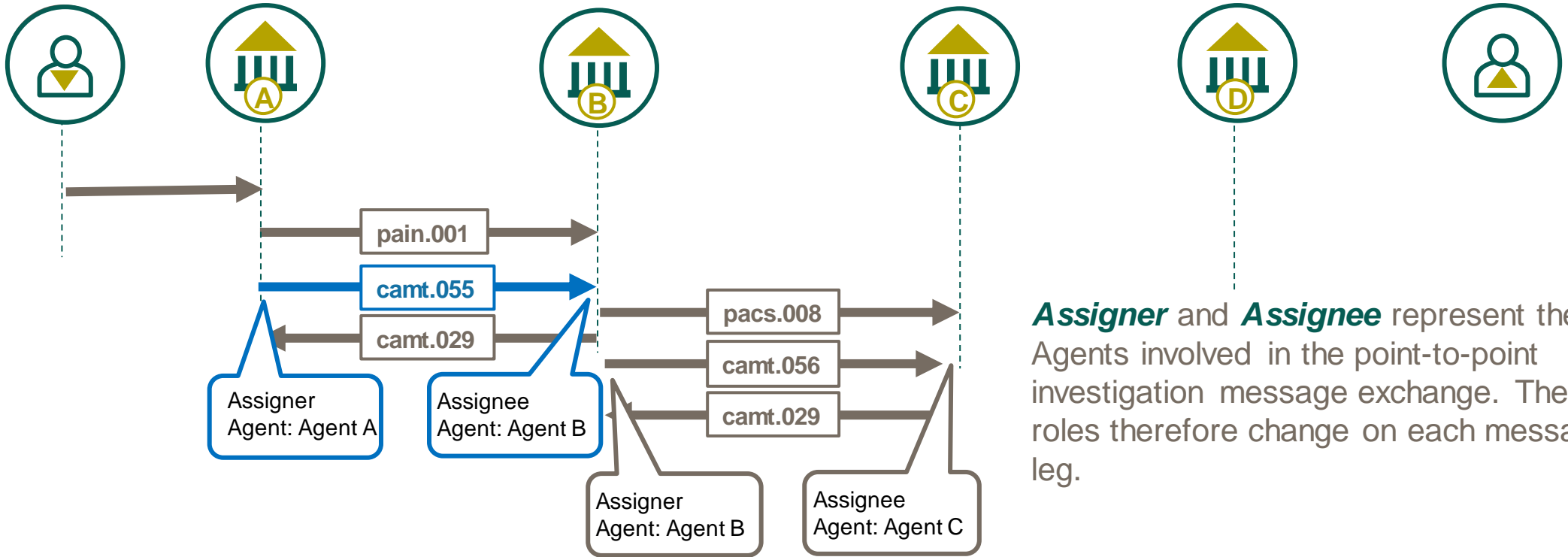

Assigner and **Assignee** represent the Agents involved in the point-to-point investigation message exchange. These roles therefore change on each message leg.

Assignment ✓

➤ Assigner

➤ Assignee



camt.055 Customer Payment Cancellation Request – Creation DateTime

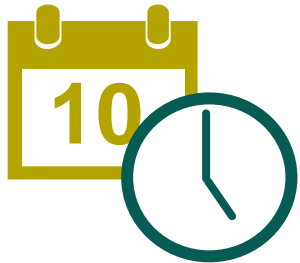

CBPR+ usage guidelines mandate the time zone that the time represents as an offset against Universal Time Coordinated (UTC):

Local time with UTC offset `YYYY-MM-DDThh:mm:ss.sss+/-hh:mm`

- For example: `2002-10-10T12:00:00-05:00` (noon/midday on 10 October 2002, Central Daylight Savings Time as well as Eastern Standard Time in the U.S.)



All CBPR+ time elements need offset against UTC. Milliseconds are optional.

Group Header ▶ Creation Date Time

Underlying – Original Payment Information and Cancellation.



camt.055 Customer Payment Cancellation Request – Original Payment Information Identification

Min 1 – Max 1

The Payment Cancellation Request message **Original Payment Information Identification** provides a mandatory element to identify the Original Payment Initiation Request

This **Unique reference** identifies the Payment Information Identification from the original Payment Initiation request. Refer to the relevant Payment Information Identification element in the original message for details on that reference.

[Link to Pain.001](#)
[Link to Pain.008](#)

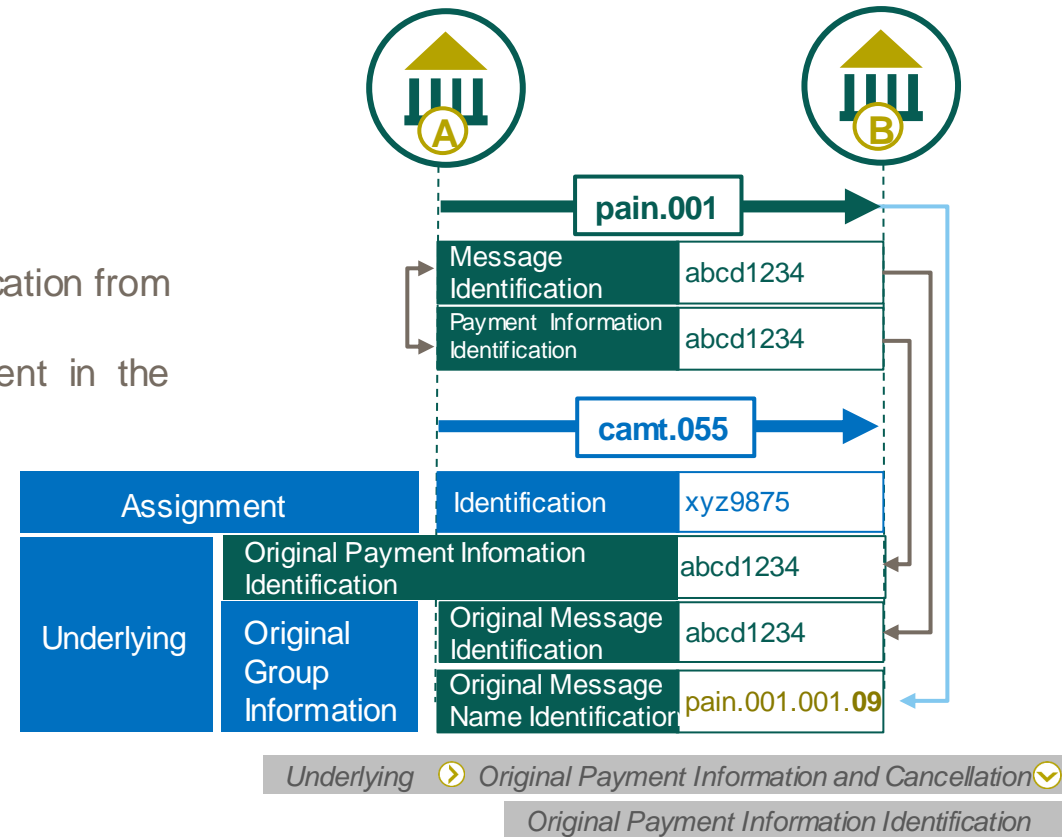

camt.055 Customer Payment Cancellation Request – Original Group Information

Min 1 – Max 1

The Payment Cancellation Request uses elements in the **Original Group Information** to capture the message identifier and message name of the underlying payment for which the Cancellation is being requested. The mandatory **Original Message Identification** contains the point-to-point reference from this payment, and the mandatory **Original Message Name Identification** contains the message name of the underlying payment. Optionally the **Original Creation Date Time** can also be captured.

For example:

Original Message Name Identification “pain.001.001.09” confirms the Cancellation request is for a pain.001 Interbank Customer Credit Transfer Initiation.

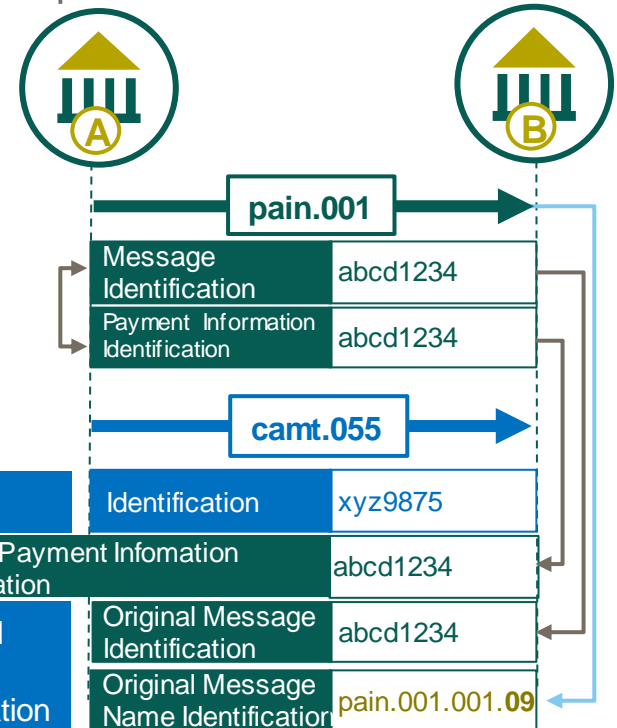

Note: the xx in the CBPR+ Usage Guideline represents the message version of the message received for example pacs.008.001.08



Underlying Original Payment Information and Cancellation

Original Group Information



camt.055 Customer Payment Cancellation Request – Cancellation Identification

Min 0 – Max 1

The Payment Cancellation Request message **Cancellation Identification** provides an optional element to identify the Request



Unique reference assigned by the assigner to unambiguously identify the Cancellation request.

For Exceptions and Investigations messages the *Cancellation Identification* can be considered an equivalent in the legacy MT Directly comparable with the *Transaction Reference Number* (Field 20) of the legacy MT statement message.

Underlying > Original Payment Information and Cancellation ✓

Transaction Identification > Cancellation Identification

camt.055 Customer Payment Cancellation Request – Case Identification

Min 1 – Max 1

The Payment Cancellation Request message **Case** provides a mandatory nested element to identify the Case **Identification** and the **Creator** of the case.

Min 1 – Max 1

The **Identification** element captures a unique case reference assigned by the assigner to unambiguously identify the Cancellation investigation case.

For Exceptions and Investigations messages the *Case Identification* can be considered an equivalent of the *Transaction Reference Number* (Field 20) of the legacy MT Request for Cancellation message.

Min 1 – Max 1

The **Creator** element captures the party who created the investigation. This mandatory party can represent as either an **Agent** i.e., the Bank who created the case or as a **Party** i.e., the customer (for example the Debtor) who created the request. In CBPR+ the creator is always expected to be an Agent.

This element has no equivalent in the legacy MT Request for Cancellation message.



Underlying > Original Payment Information and Cancellation

Transaction Identification > Case

camt.055 Customer Payment Cancellation Request – Transaction Information elements

The Payment Cancellation Request also uses a number of other **Original** elements in the **Transaction Information** to capture information from the underlying payment that the Cancellation request relates to.

The Original elements enables the **Assignee** to identify the Payment which is being request to be cancelled. The following element (in addition to *Original Message identification* and *Original Message Name Identification*) are mandated:

Original End to End Identification

Min 1 – Max 1

Original UETR

Min 1 – Max 1

Original Instructed Amount

Min 1 – Max 1



One of the following elements is also required depending on the Date element in the original message, where Original Request Execution Date relates to the pain.001 and Original Request Collection Date relates to the pain.008 :

Original Requested Execution Date

Min 0 – Max 1

Original Request Collection Date

Min 0 – Max 1

The following element is optional:

Original Instruction Identification

Min 0 – Max 1

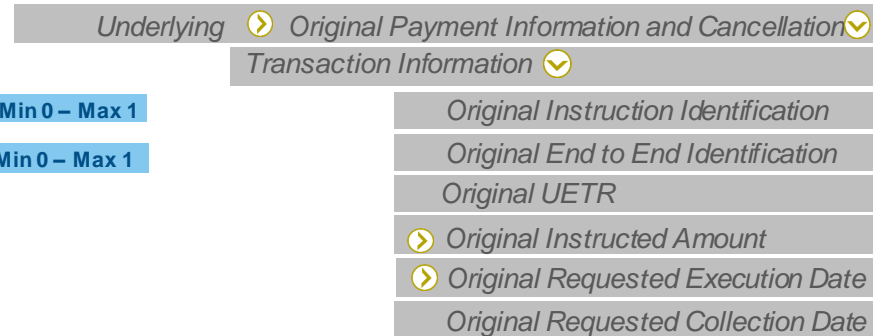

camt.055 Customer Payment Cancellation Request – Cancellation Reason Information

Min 1 – Max 1

The Payment Cancellation Request **Cancellation Reason Information** nested element captures information associated with the reason for the Cancellation request.

Min 0 – Max 1

the **Originator** element helps identify the party who request the payment Cancellation. This party would have been included in the underlying payment and is also included the pacs.004 *Return Chain as the Creditor*.

Min 1 – Max 1

the **Reason** is mandatory and represented by an embedded CBPR+ Cancellation **Code** choice (☒)

Min 0 – Max 2

the **Additional Information** element may also be included to provide further details on the Cancellation reason.



Note where Reason code NARR is used additional information must be provided to describe the reason for the Cancellation request.

Underlying > Original Payment Information and Cancellation

Transaction Information > Cancellation Reason Info

> Originator

> Reason

Additional Information

camt.055 Customer Payment Cancellation Request – Cancellation Reason codes

Definitions and High Level Use Cases

Min 1 – Max 1

The Payment Cancellation Request **Reason** element is mandatory. CBPR+ have defined a sub-set of the ISO externalised code list which is represented as an embedded **Code** choice. This list ensures interoperability with the legacy FIN request for Cancellation message, which can be broadened after the coexistence period.

Code	Name	Definition	Use Case
AGNT	Incorrect Agent	Agent in the payment workflow is incorrect.	A payment previous executed is identified as containing an incorrect correspondent (Agent) within the payment flow. A Cancellation request is generated so that the payment can be remediated following the successful return.
AM09	Wrong Amount	Amount is not the amount agreed or expected.	The customer (Debtor) requests the initiation of a payment from their bank account, but subsequently realizes they had provided an incorrect amount.
CURR	Incorrect Currency	Currency of the payment is incorrect.	The customer (Debtor) requests the initiation of a payment from their bank account, but subsequently realizes they requested the wrong currency, as the payment has been executed. They request their bank to recall the funds so that the payment can be re-executed in the correct currency
CUST	Requested By Customer	Cancellation requested by the Debtor.	The customer (Debtor) requests the initiation of a payment from their bank account, but subsequently wishes to recall the payment. The exactly underlying reason for the customer request is either not specified by the customer or is not aligned to a more specific reason and therefore is not appropriate.

camt.055 Customer Payment Cancellation Request – Cancellation Reason codes (continued)

Definitions and High Level Use Cases

Code	Name	Definition	Use Case
CUTA	Cancel Upon Unable To Apply	Cancellation requested because an investigation request has been received and no remediation is possible.	An error occurred in the original payment (such as incorrect information) which was highlighted as part of an Investigation query. The request to cancel complements a response to the Investigation.
DUPL	Duplicate Payment	Payment is a duplicate of another payment.	A customer (Debtor) requests the initiation of a payment from their bank account, but subsequently initiates a new (separate) payment request in duplication of a previous payment. Having realized the error, the customer requests the recall of the duplicate transaction.
FRAD	Fraudulent Origin	Cancellation requested following a transaction that was originated fraudulently. The use of the Fraudulent Origin code should be governed by jurisdictions.	Either the customer (Debtor) or a bank (Agent) in the payment transaction experiences an activity which causes a payment to be executed by alleged fraudulent means.
NARR	Narrative	Narrative reason provided in the Additional Information.	Used only where a more specific reason is not appropriate. Narrative description is provided.
TECH	Technical Problem	Cancellation requested following technical problems resulting in an erroneous transaction.	Either the customer (Debtor) or a bank (Agent) in the payment flow experiences a technology issue which causes data within a payment to be incorrect.
UPAY	Undue Payment	Payment is not justified.	Either the customer (Debtor) or a bank (Agent) in the payment flow experiences an activity which causes a payment to be executed under unexpected circumstances.

Index of camt.055 Use Cases



Use case should be considered as a principal example whereby use case may be cross referenced

Payment Cancellation Request

Use Case c.55.1.1 –

High Level Direct Debit Initiation Interbank 'relay' (pain.008)

In the interbank relay scenario, the Forwarding Agent relays the pain.008 message to the Creditor Agent to request the collections of funds from the debtor's accounts for a creditor.

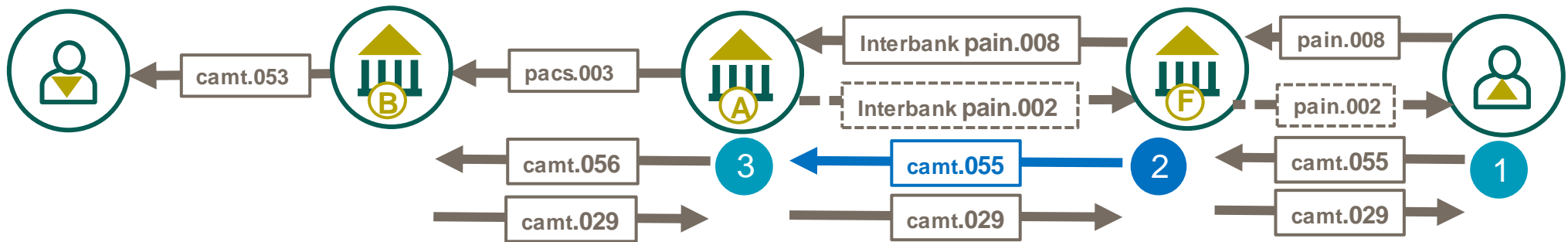

1 Creditor request the recall a previous instructed Direct Debit collection, as the amount was incorrect.

2 Forwarding Agent (F) assigns a Customer Cancellation Request to Agent A (assignee) requesting the original pain.008 is cancelled, using reason code AM09.

3 Creditor Agent (A) assigns a Cancellation Request to Agent B (assignee) requesting the original pacs.003 is cancelled, using reason code AM09.

High Level Direct Debit Initiation Interbank 'relay' (pain.008) involving a Payment Market Infrastructure

In the interbank relay scenario, the Forwarding Agent relays the pain.008 message to the Creditor Agent to request the collection of funds from the debtor's accounts for a creditor (through a Payment Market Infrastructure).

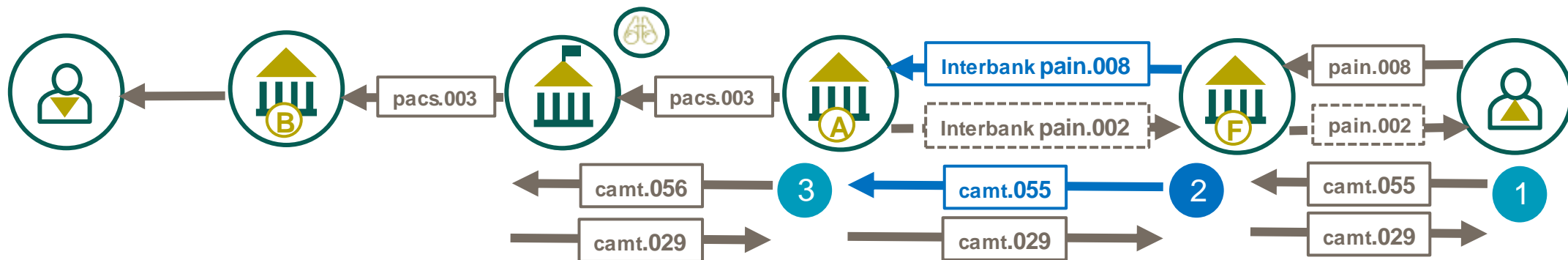

1 Creditor request the recall a previous instructed Direct Debit collection, as the amount was incorrect.

2 Forwarding Agent (F) assigns a Customer Cancellation Request to Agent A (assignee) requesting the original pain.008 is cancelled, using reason code AM09.

3 Creditor Agent (A) assigns a Cancellation Request to Agent B (assignee) requesting the original pacs.003 is cancelled, using reason code AM09.



camt.056

Financial Institution to Financial Institution Payment Cancellation Request



camt.056 FI to FI Payment Cancellation Request

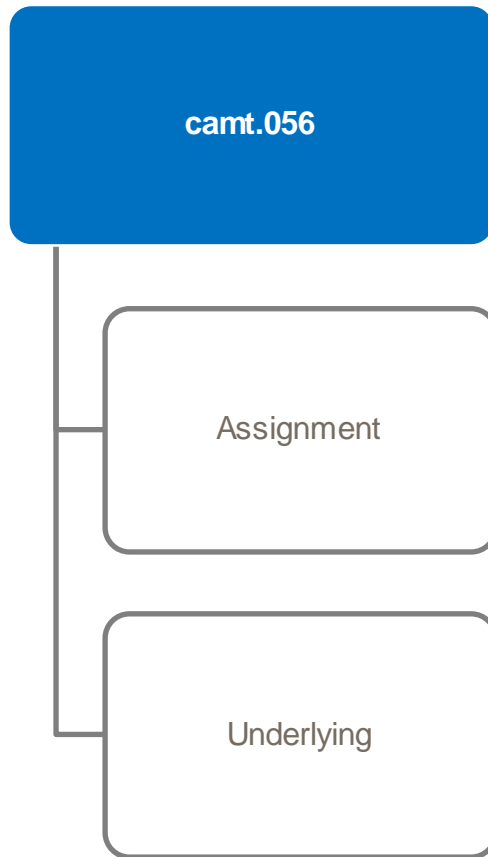

The FI to FI Payment Cancellation Request message is sent by an Agent to request the Cancellation of a payment previous sent.

The message is sent either:

- directly (through the SWIFT Community CASE solution), or
- serially through other agents.



It is not recommended to request a Payment Cancellation Request (camt.056) of a Payment Return (pacs.004) instead an Exception and Investigation should be initiated to resolve this exertional use case

High Level (Serial) FI to FI Payment Cancellation Request (camt.056)

camt.056

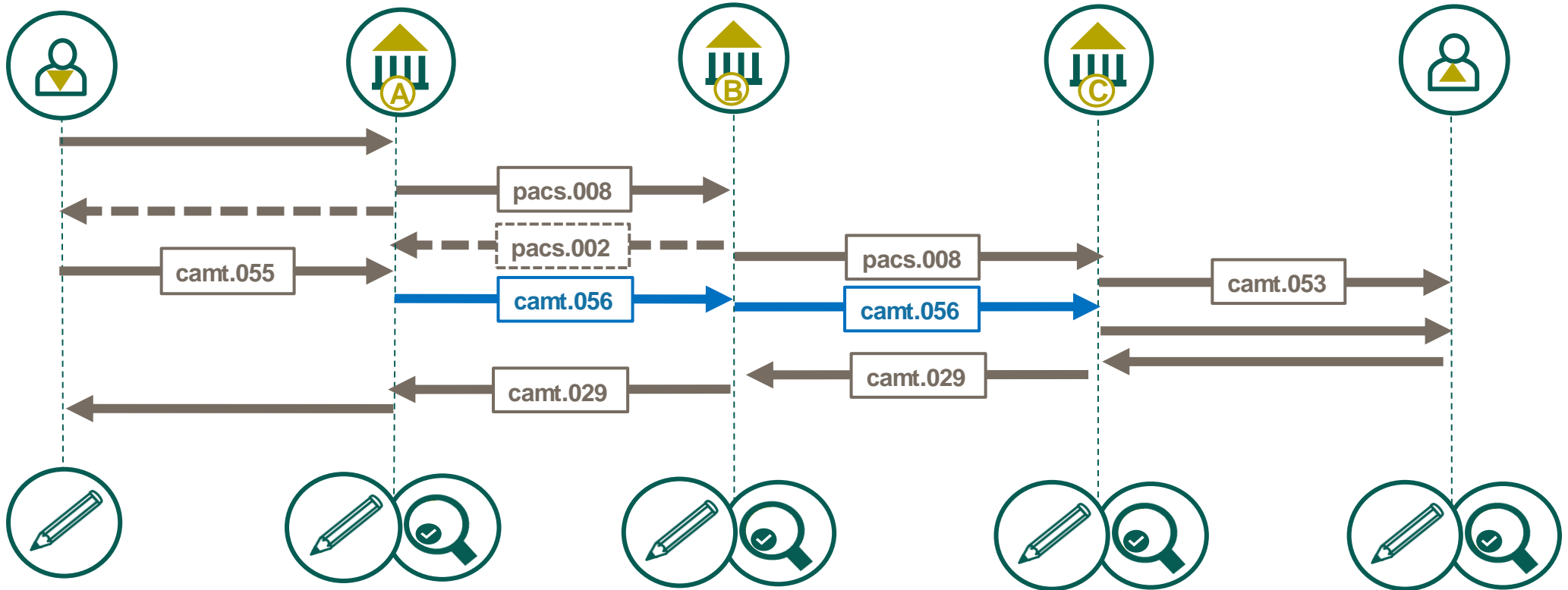

The FIToFIPaymentCancellationRequest message is sent by a case creator/case assigner to a case assignee. This message is used to request the cancellation of an original payment instruction (pre or post settlement to the Creditor). The FIToFIPaymentCancellationRequest message is exchanged between the payment Instructing Agent and the Instructed Agent to request the cancellation of an interbank payment message previously sent.

High Level (Direct) FI to FI Payment Cancellation Request (camt.056)

camt.056

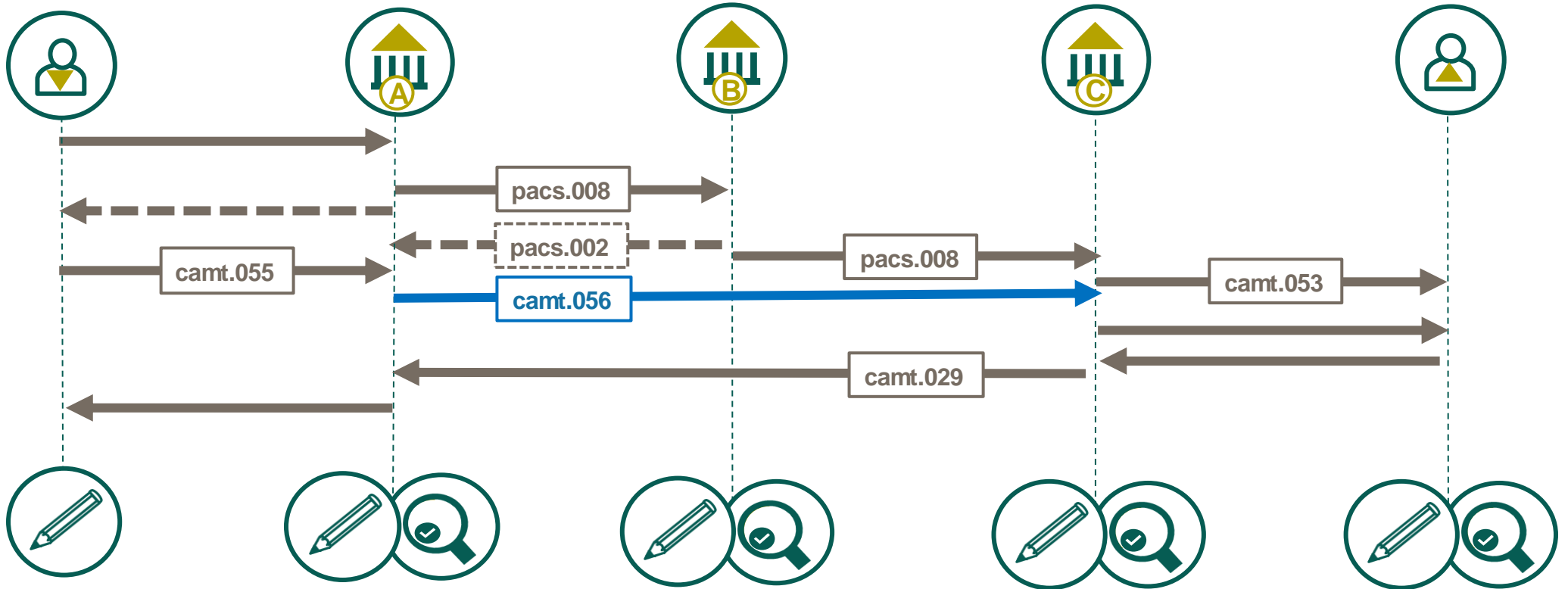

The FIToFIPaymentCancellationRequest message is sent by a case creator/case assigner to a case assignee. This message is used to request the cancellation of an original payment instruction (pre or post settlement to the Creditor). The FIToFIPaymentCancellationRequest message is exchanged between the payment Instructing Agent and the Instructed Agent to request the cancellation of an interbank payment message previously sent.

camt.056 FI to FI Payment Cancellation Request – High Level Overview

The camt.056 Payment Cancellation Request and camt.029 Resolution of Investigation messages have a number of identification elements, of which some are used for cross referencing. The below provides a high level overview.

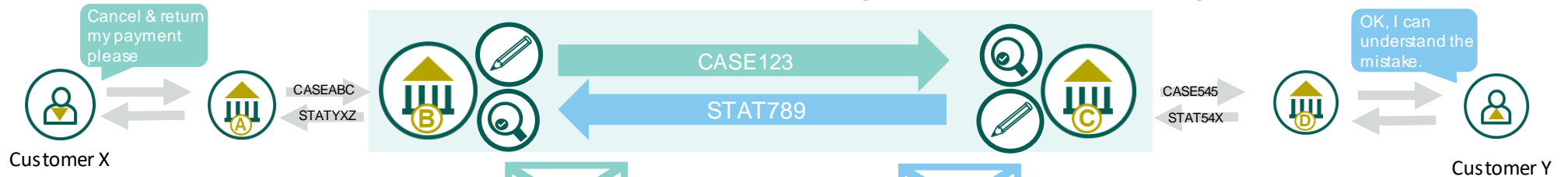

Camt.056 Payment Cancellation Request

ISO



element	description	example
Assigner	Sender of the camt.056	Agent B
Assignee	Receiver of the camt.056	Agent C
Assignment Identification	Unique Id generated by the assigner to identify the Payment Cancellation Request message	CASE123/1
Cancellation identification	Optional Cancellation Id of the Agent sending (assigner) the Payment Cancellation Request message.	CASE123
Case Identification	Case Id of the Agent sending (assigner) the Payment Cancellation Request message.	CASE123
Case Creator	Party w ho created the original cancellation request (w hich may be another Agent other than the current Assigner).	Agent A
Cancellation Reason... Originator	Party w ho provide the original Payment Cancellation Request (w hich may be another Party other than the current Assigner).	Customer X



camt.029 Resolution of Investigation

element	description	example
Assigner	Sender of the camt.029	Agent C
Assignee	Receiver of the camt.029	Agent B
Assignment Identification	Unique Id generated by the assigner to identify the Resolution of Investigation message	STAT789/1
Cancellation Status Identification	Case Reference of the Agent sending (assigner) the Resolution of Investigation message.	STAT789
Resolved (Original) Case Identification	Case Id of the original case the Resolution of Investigation is responding to.	CASE123
Case Creator	Party w ho created the original cancellation request (w hich is the same original case creator in the Payment Cancellation Request)	Agent A
Cancellation Status... Originator	Party w ho provide the original Cancellation response (w hich may be another Party other than the current Assigner).	Customer Y



Assignment



camt.056 FI to FI Payment Cancellation Request - Identification

Min 1 – Max 1

The Payment Cancellation Request message **Identification** provides a mandatory element to identify the Request



Unique reference assigned by the assigner to unambiguously identify the Cancellation request.

For Exceptions and Investigations messages the Identification has no exact equivalent in the legacy MT Exceptions and Investigations message. However, the Transaction Reference Number (Field 20) could be considered a similar comparison.

Directly comparable with the *Transaction Reference Number* (Field 20) of the legacy MT statement message.

camt.056 FI to FI Payment Cancellation Request - Assigner and Assignee

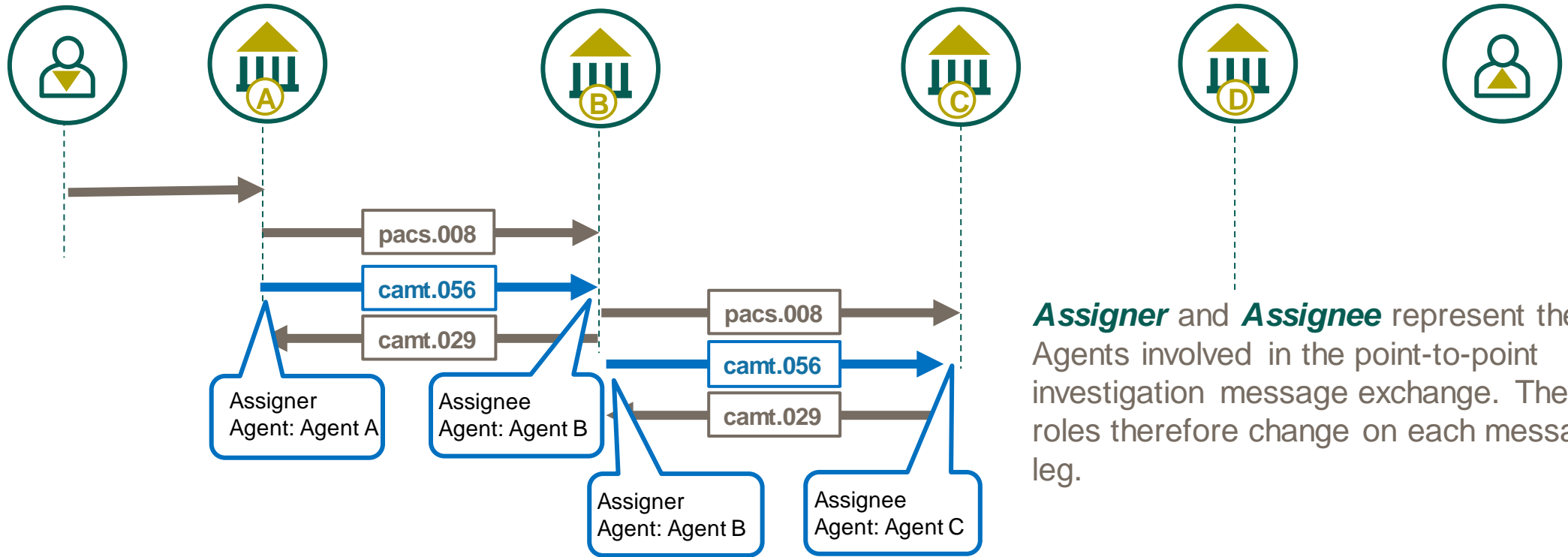

Assigner and **Assignee** represent the Agents involved in the point-to-point investigation message exchange. These roles therefore change on each message leg.

Assignment

Assigner

Assignee



camt.056 FI to FI Payment Cancellation Request – Creation DateTime

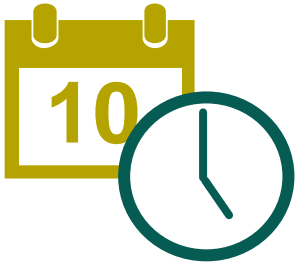

CBPR+ usage guidelines mandate the time zone that the time represents as an offset against Universal Time Coordinated (UTC):

Local time with UTC offset `YYYY-MM-DDThh:mm:ss.sss+/-hh:mm`

- For example: `2002-10-10T12:00:00-05:00` (noon/midday on 10 October 2002, Central Daylight Savings Time as well as Eastern Standard Time in the U.S.)



All CBPR+ time elements need offset against UTC. Milliseconds are optional.

Group Header ▶ Creation Date Time

Underlying – Transaction Information



camt.056 FI to FI Payment Cancellation Request – Cancellation Identification

Min 0 – Max 1

The Payment Cancellation Request message **Cancellation Identification** provides an optional element to identify the Request



Unique reference assigned by the assigner to unambiguously identify the Cancellation request.

For Exceptions and Investigations messages the *Cancellation Identification* can be considered an equivalent in the legacy MT Directly comparable with the *Transaction Reference Number* (Field 20) of the legacy MT statement message.



Where Cancellation Identification is used this should represent the reference value as the Case Identification

Underlying > Transaction Information >

> Cancellation Identification

camt.056 FI to FI Payment Cancellation Request – Case Identification

Min 1 – Max 1

The Payment Cancellation Request message **Case** provides a mandatory nested element to identify the Case **Identification** and the **Creator** of the case.

Min 1 – Max 1

The **Identification** element captures a unique case reference assigned by the assigner to unambiguously identify the Cancellation investigation case.

For Exceptions and Investigations messages the *Case Identification* can be considered an equivalent of the *Transaction Reference Number* (Field 20) of the legacy MT Request for Cancellation message.

Min 1 – Max 1

The **Creator** element captures the party who created the investigation. This mandatory party can represent as either an **Agent** i.e., the Bank who created the case or as a **Party** i.e., the customer (for example the Debtor) who created the request. In CBPR+ the creator is always expected to be an Agent.

This element has no equivalent in the legacy MT Request for Cancellation message.



Underlying > Transaction Information >

> Case

camt.056 FI to FI Payment Cancellation Request – Original Group Information

Min 1 – Max 1

The Payment Cancellation Request uses elements in the **Original Group Information** to capture the message identifier and message name of the underlying payment for which the Cancellation is being requested. The mandatory **Original Message Identification** contains the point-to-point reference from this payment, and the mandatory **Original Message Name Identification** contains the message name of the underlying payment. Optionally the **Original Creation Date Time** can also be captured.

For example:

Original Message Name Identification “pacs.008.001.08” confirms the Cancellation request is for a pacs.008 Financial Institution to Financial Institution Customer Credit Transfer. Where as “pacs.009.001.08” confirms the Cancellation request for a pacs.009 Financial Institution Credit Transfer.

 Note: the xx in the CBPR+ Usage Guideline represents the message version of the message received for example pacs.008.001.08

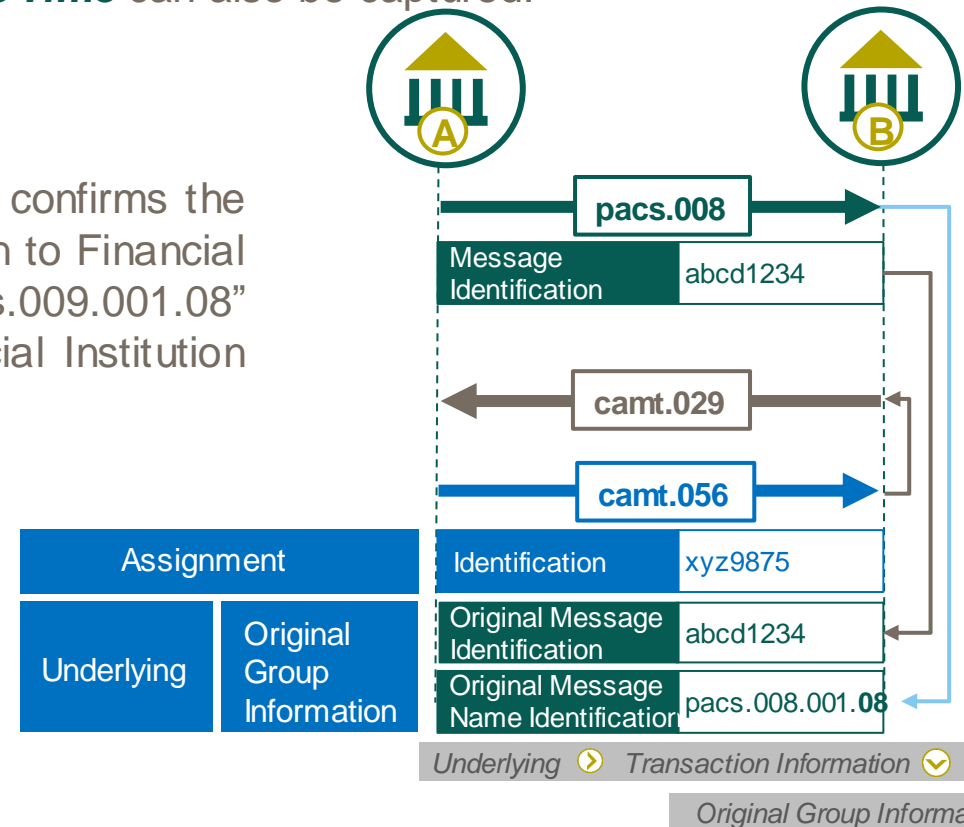

camt.056 FI to FI Payment Cancellation Request – Original elements

The Payment Cancellation Request also uses a number of other **Original** elements in the **Transaction Information** to capture information from the underlying payment that the Cancellation request relates to.

The Original elements enables the **Assignee** to identify the Payment which is being request to be cancelled. The following element (in addition to *Original Message identification* and *Original Message Name Identification* described on the previous page) are mandated:

Original End to End Identification Min 1 – Max 1

Original UETR Min 1 – Max 1

Original Interbank Settlement Amount Min 1 – Max 1

Original Interbank Settlement Date Min 1 – Max 1

The following element (in addition to *Original Message identification* and *Original Message Name Identification* described on the previous page) are optional:

Original Instruction Identification Min 0 – Max 1

Original Transaction Identification Min 0 – Max 1

Original Clearing System Reference Min 0 – Max 1

Underlying	Transaction Information
	Original Instruction Identification
	Original End to End Identification
	Original Transaction
	Original UETR
	Original Clearing System Reference
	Original Interbank Settlement Amount
	Original Interbank Settlement Date



camt.056 FI to FI Payment Cancellation Request – Cancellation Reason Information

Min 1 – Max 1

The Payment Cancellation Request **Cancellation Reason Information** nested element captures information associated with the reason for the Cancellation request.

Min 0 – Max 1



the **Originator** element helps identify the party who request the payment Cancellation. This party would have been included in the underlying payment and is also included the pacs.004 *Return Chain as the Creditor*.

Min 1 – Max 1

the **Reason** is mandatory and represented by an embedded CBPR+ Cancellation **Code** choice (↔)

Min 0 – Max 2



the **Additional Information** element may also be included to provide further details on the Cancellation reason.



Note where Reason code NARR is used additional information must be provided to describe the reason for the Cancellation request.

Underlying > Transaction Information > Cancellation Reason Info >

> Originator

> Reason

Additional Information



In the event that the case assigner wishes it indicate a willingness to establish an **indemnity agreement**, **INDM** should be indicated at the beginning of the Additional Information element. Any subsequent additional information may then be included.



camt.056 FI to FI Payment Cancellation Request – Cancellation Reason codes

Min 1 – Max 1

The Payment Cancellation Request **Reason** element is mandatory. CBPR+ have defined a sub-set of the ISO externalised code list which is represented as an embedded **Code** choice. This list ensures interoperability with the legacy FIN request for Cancellation message, which can be broadened after the coexistence period.

Code	Name	Definition	Use Case
AGNT	Incorrect Agent	Agent in the payment workflow is incorrect.	A payment previous executed is identified as containing an incorrect correspondent (Agent) within the payment flow. A Cancellation request is generated so that the payment can be remediated following the successful return.
AM09	Wrong Amount	Amount is not the amount agreed or expected.	The customer (Debtor) requests the initiation of a payment from their bank account, but subsequently realizes they had provided an incorrect amount.
COVR	Cover Cancelled Or Returned	Cover payments has either been returned or cancelled.	Identifies an Agent to request the Cancellation of a pacs message where settlement method was COVE and the covering payment has been cancelled or returned.
CURR	Incorrect Currency	Currency of the payment is incorrect.	The customer (Debtor) requests the initiation of a payment from their bank account, but subsequently realizes they requested the wrong currency, as the payment has been executed. They request their bank to recall the funds so that the payment can be re-executed in the correct currency
CUST	Requested By Customer	Cancellation requested by the Debtor.	The customer (Debtor) requests the initiation of a payment from their bank account, but subsequently wishes to recall the payment. The exactly underlying reason for the customer request is either not specified by the customer or is not aligned to a more specific reason and therefore is not appropriate.



camt.056 FI to FI Payment Cancellation Request – Cancellation Reason codes (continued)

Code	Name	Definition	Use Case
CUTA	Cancel Upon Unable To Apply	Cancellation requested because an investigation request has been received and no remediation is possible.	An error occurred in the original payment (such as incorrect information) which was highlighted as part of an Investigation query. The request to cancel complements a response to the Investigation.
DUPL	Duplicate Payment	Payment is a duplicate of another payment.	A customer (Debtor) requests the initiation of a payment from their bank account, but subsequently initiates a new (separate) payment request in duplication of a previous payment. Having realized the error, the customer requests the recall of the duplicate transaction.
FRAD	Fraudulent Origin	Cancellation requested following a transaction that was originated fraudulently. The use of the Fraudulent Origin code should be governed by jurisdictions.	Either the customer (Debtor) or a bank (Agent) in the payment transaction experiences an activity which causes a payment to be executed by alleged fraudulent means.
NARR	Narrative	Narrative reason provided in the Additional Information.	Used only where a more specific reason is not appropriate. Narrative description is provided.
TECH	Technical Problem	Cancellation requested following technical problems resulting in an erroneous transaction.	Either the customer (Debtor) or a bank (Agent) in the payment flow experiences a technology issue which causes data within a payment to be incorrect.
UPAY	Undue Payment	Payment is not justified.	Either the customer (Debtor) or a bank (Agent) in the payment flow experiences an activity which causes a payment to be executed under unexpected circumstances.

Index of camt.056 Use Cases

Use case should be considered as a principal example whereby use case may be cross referenced

Payment Cancellation Request

Use Case c.56.1.1 – High Level Payment Cancellation Request (camt.056) of a completed Customer Credit Transfer (pacs.008)

Use Case c.56.1.1.a – High Level Payment Cancellation Request (camt.056) of a completed Customer Credit Transfer (pacs.008) using gpi Stop and Recall

Use Case c.56.1.2 – High Level Payment Cancellation Request (camt.056) of an incomplete Customer Credit Transfer (pacs.008)

Use Case c.56.1.2.a – High Level Payment Cancellation Request (camt.056) of an incomplete Customer Credit Transfer (pacs.008) using gpi Stop and Recall

Use Case c.56.2.1 – High Level Payment Cancellation Request (camt.056) of a complete Customer Credit Transfers (pacs.008) settled using the cover method

Use Case c.56.2.2 – High Level Payment Cancellation Request (camt.056) of an incomplete Customer Credit Transfers (pacs.008) settled using the cover method

Use Case c.56.2.3 – High Level Payment Cancellation Request (camt.056) of a Customer Credit Transfers (pacs.008) where the cover is returned

Use Case c.56.3.1 – High Level Payment Cancellation Request (camt.056) of a Financial Institution Credit Transfer (pacs.009)

Use Case c.56.4.1 – High Level Payment Cancellation Request (camt.056) of a Financial Institution Credit Transfer advice (pacs.009 adv)

High Level Payment Cancellation Request (camt.056) of a completed Customer Credit Transfer (pacs.008)

Use Case c.56.1.1

 See use case [p.8.1.1](#) for the original payment, [c.29.1.1](#) for case resolution and [p.4.1.3](#) for an example payment return

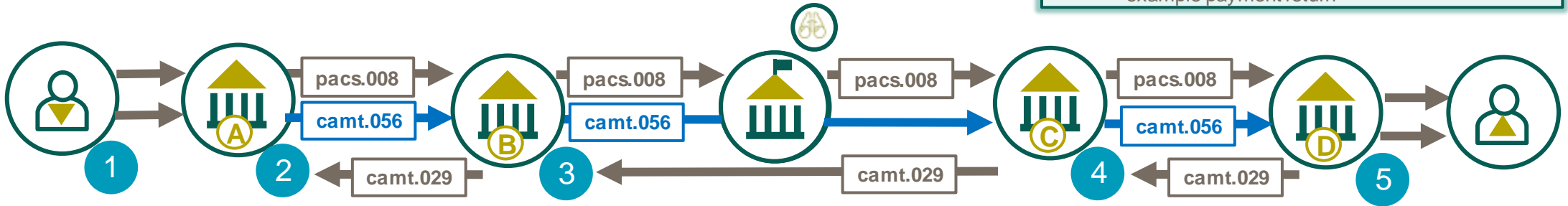

1 Debtor request their bank to recall a previous instructed payment, as the amount was incorrect.

2 Debtor Agent (A) assigns a Cancellation Request to Agent B (assignee) requesting the original pacs.008 is returned, using reason code AM09.

3 Agent B creates an investigation case. Recognising the payment has already been onward processed. They update Agent A and assign a Cancellation Request directly to Agent C.

4 Agent C creates an investigation case. Recognising the payment has already been onward processed. They update Agent B and assign a Cancellation Request directly to Agent D.

5 Agent D creates an investigation case. Recognising the payment has already been credited to the creditor. They request debit authority, providing the reason specified for the return request and updates Agent C. Once the outcome to the debit authorisation is know a final resolution to the investigation can be relayed any necessary return payment is arrange.



High Level Payment Cancellation Request (camt.056) of a completed Customer Credit Transfer (pacs.008) using gpi Stop and Recall

Use Case c.56.1.1.a

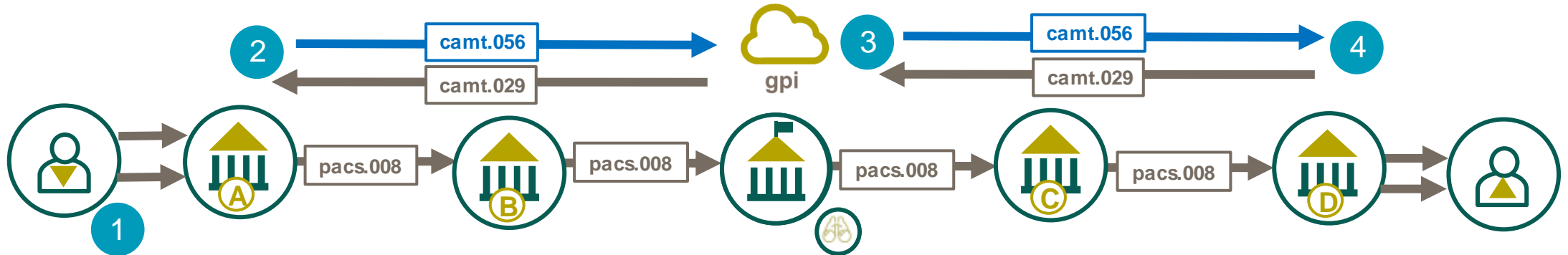

See use case [p.8.1.1](#) for the original payment, [c.29.1.1](#) for case resolution and [p.4.1.3](#) for an example payment return

1

Debtor request their bank to recall a previous instructed payment, as the amount was incorrect.

2

Debtor Agent (A) initiates a gpi Stop and Recall, requesting the original pacs.008 is returned, using reason code AM09.

3

gpi Tracker identifies the payment is complete and forwards a camt.056 to Agent D.

4

Agent D creates an investigation case. Recognising the payment has already been credited to the creditor. They request debit authority, providing the reason specified for the return request and updates the gpi Tracker. Once the outcome to the debit authorisation is known a final resolution to the investigation can be provided and any necessary return payment is arranged.



High Level Payment Cancellation Request (camt.056) of an incomplete Customer Credit Transfer (pacs.008) Use Case c.56.1.2

 See use case [p.8.1.1](#) for the original payment, [c.29.1.2](#) for case resolution and [p.4.1.3](#) for an example payment return

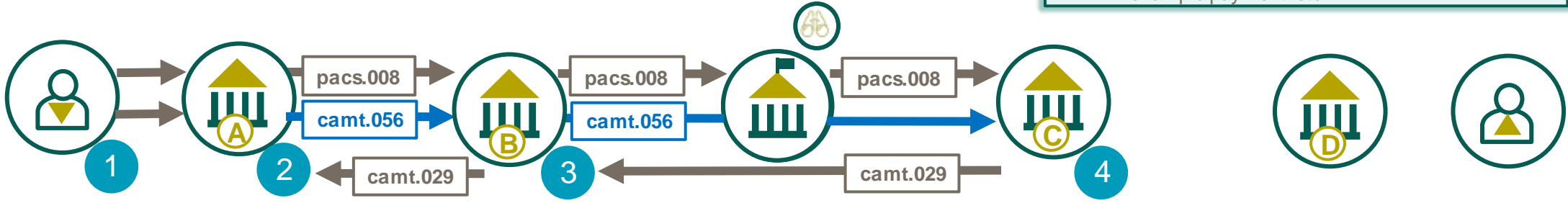

1 Debtor request their bank to recall a previous instructed payment, as the amount was incorrect.

2 Debtor Agent (A) assigns a Cancellation Request to Agent B (assignee) requesting the original pacs.008 is returned, using reason code AM09.

3 Agent B creates an investigation case. Recognising the payment has already been onward processed. They update Agent A and assign a Cancellation Request directly to Agent C.

4 Agent C creates an investigation case. Recognising the payment has not been onward processed. They update Agent B that the Cancellation Request is accepted any necessary return payment is arrange.



High Level Payment Cancellation Request (camt.056) of an incomplete Customer Credit Transfer (pacs.008) using gpi Stop and Recall

Use Case c.56.1.2.a

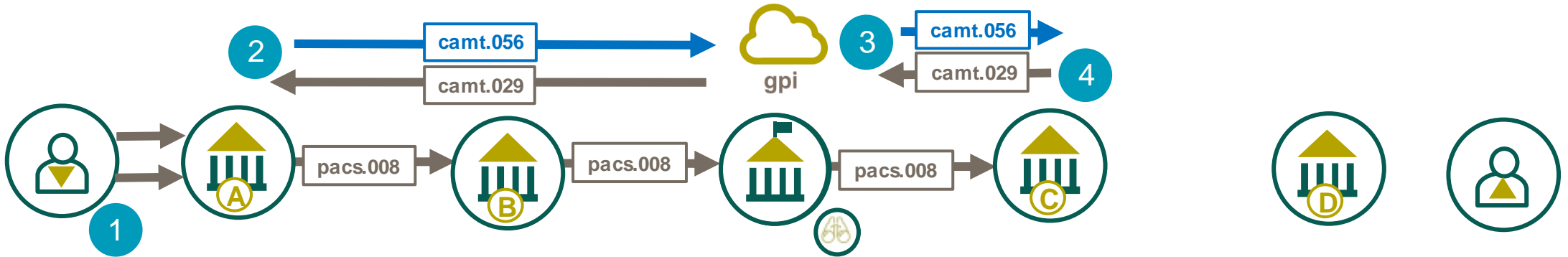

1 Debtor request their bank to recall a previous instructed payment, as the amount was incorrect.

3 gpi Tracker identifies the payment is incomplete and forwards a camt.056 to Agent C.

4 Agent C creates an investigation case. Recognising the payment has not been onward processed. They updates the gpi Tracker any necessary return payment is arrange.

2 Debtor Agent (A) initiates a gpi Stop and Recall, requesting the original pacs.008 is returned, using reason code AM09.



High Level Payment Cancellation Request (camt.056) of a Customer Credit Transfer (pacs.008) settled using a cover method.

Use Case c.56.2.1

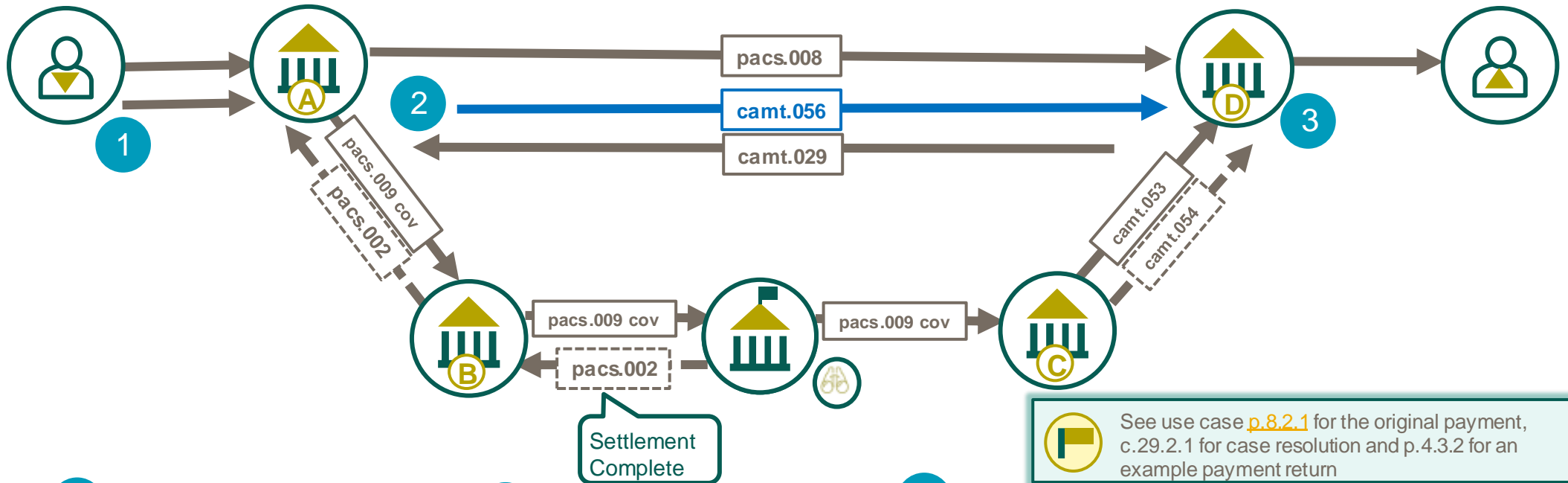

1 Debtor request their bank to recall a previous instructed payment, as the amount was incorrect.

2 Debtor Agent (A) assigns a Cancellation Request to Agent D (assignee) requesting the original pacs.008 is returned, using reason code AM09.

3 Agent D creates an investigation case. Recognising the payment has already been credited to the creditor. They request debit authority, proving the reason specified for the return request and update Agent A. Once the outcome to the debit authorisation is know a final resolution to the investigation can be relayed and any necessary return payment can be initiated.

See use case [p.8.2.1](#) for the original payment, [c.29.2.1](#) for case resolution and [p.4.3.2](#) for an example payment return



High Level Payment Cancellation Request (camt.056) of an incomplete Customer Credit Transfer (pacs.008) settled using a cover method. Use Case c.56.2.2

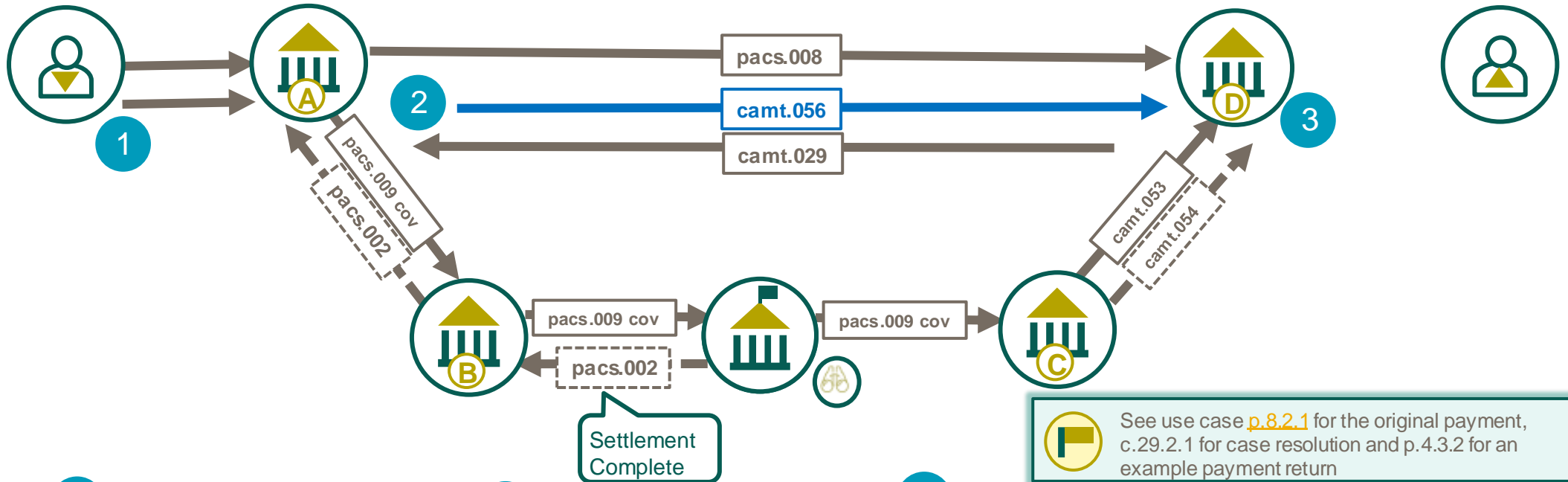

1 Debtor request their bank to recall a previous instructed payment, as the amount was incorrect.

2 Debtor Agent (A) assigns a Cancellation Request to Agent D (assignee) requesting the original pacs.008 is returned, using reason code AM09.

3 Agent D creates an investigation case. Recognising the payment has not been credited to the creditor. They update Agent A that the Cancellation Request is accepted and arrange the necessary return payment once the pacs.009 cov settlement is confirmed by Agent C



High Level Payment Cancellation Request (camt.056) of a Customer Credit Transfers (pacs.008) where the cover is returned

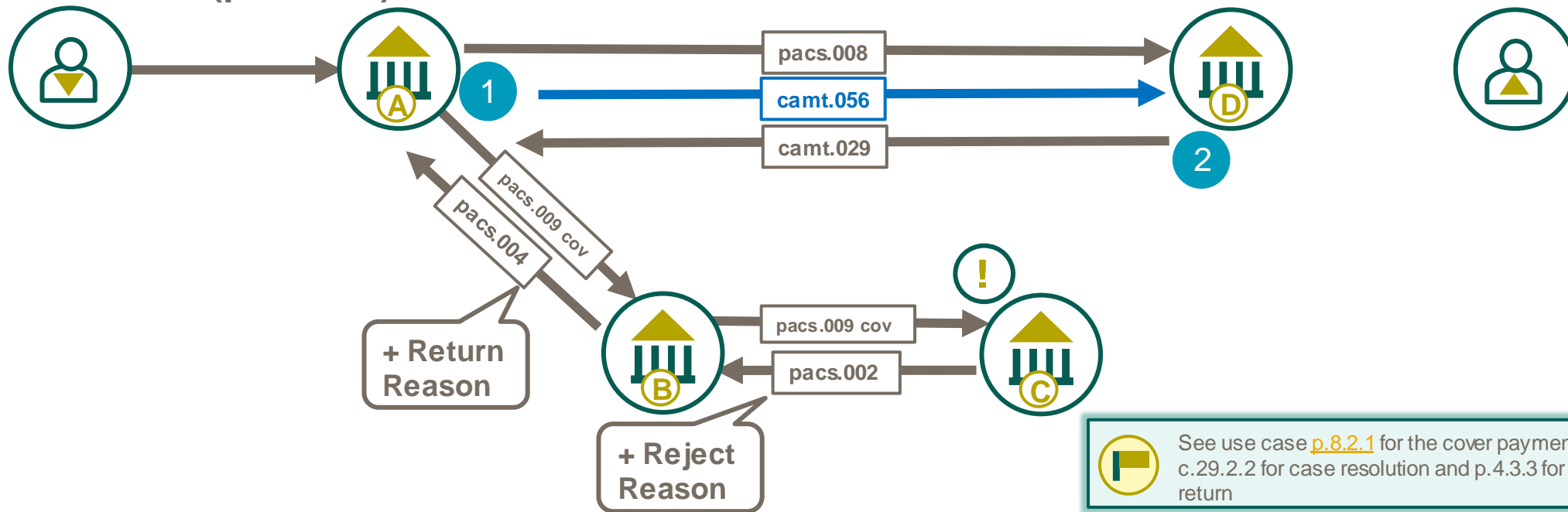

! Agent C receives the payment and recognises the payment can not be completed as requested e.g. the Agent D does not maintain an account with them.

1 Debtor Agent (A) assigns a Cancellation Request to Agent D (assignee) requesting the original pacs.008 is considered null and void, using reason code COVR.

2 Agent D creates an investigation case. Recognising the cover payment will not be received to settle the pacs.008. As the creditor has not been credited in advance of cover settlement, a final resolution to the investigation can be provided. A payment return is not necessary.

See use case [p.8.2.1](#) for the cover payment sample c.29.2.2 for case resolution and p.4.3.3 for payment return

High Level Payment Cancellation Request (camt.056) of a Financial Institution Credit Transfer (pacs.009)

Use Case c.56.3.1

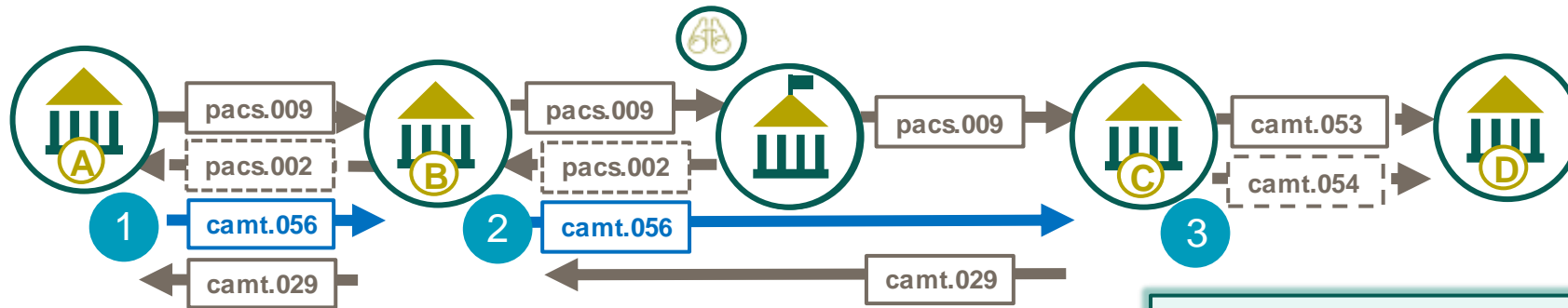

 See use case p.9.1.1 for the cover payment sample c.29.3.1 for case resolution and p.4.2.3 for payment return

1 Debtor request their bank to recall a previous instructed payment, as the amount was incorrect.

2 Debtor Agent (A) assigns a Cancellation Request to Agent C (assignee) requesting the original pacs.009 is returned, using reason code AM09.

3 Agent C creates an investigation case. Recognising the payment has already been credited to the creditor. They request debit authority, proving the reason specified for the return request and update Agent C. Once the outcome to the debit authorisation is know a final resolution to the investigation can be relayed and any necessary return payment can be initiated.



High Level Payment Cancellation Request (camt.056) of a Financial Institution

Credit Transfer advice (pacs.009 adv)

Use Case c.56.4.1

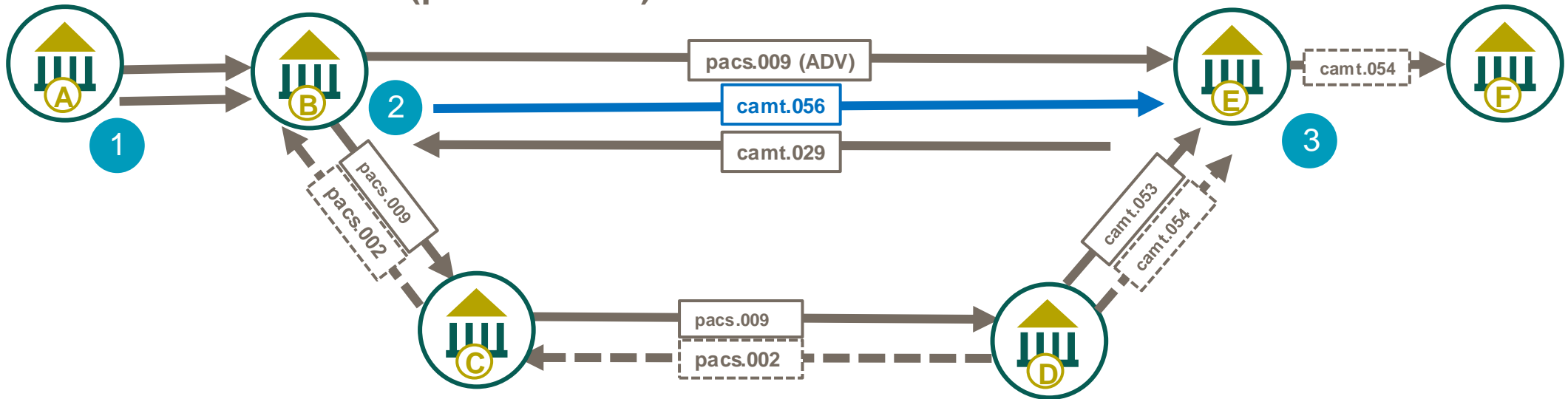

 See use case p.9.1.2 for the cover payment sample c.29.4.1 for case resolution and p.4.2.3 for payment return

1 Debtor request their bank to recall a previous instructed payment, as the amount was incorrect.

2 Debtor Agent (A) assigns a Cancellation Request to Agent E (assignee) requesting the original pacs.008 is returned, using reason code AM09.

3 Agent E creates an investigation case. Recognising the payment has already been credited to the creditor. They request debit authority, proving the reason specified for the return request and update Agent B. Once the outcome to the debit authorisation is know a final resolution to the investigation can be relayed and any necessary return payment can be initiated.



Cheque - Messages index

[camt.107 – Cheque Presentment Notification](#)

[camt.108 - Cheque Cancellation or Stop Request](#)

[camt.109 – Cheque Cancellation or Stop Report](#)

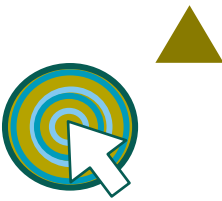



Cheque Presentment Notification

camt.107 Cheque Presentment Notification

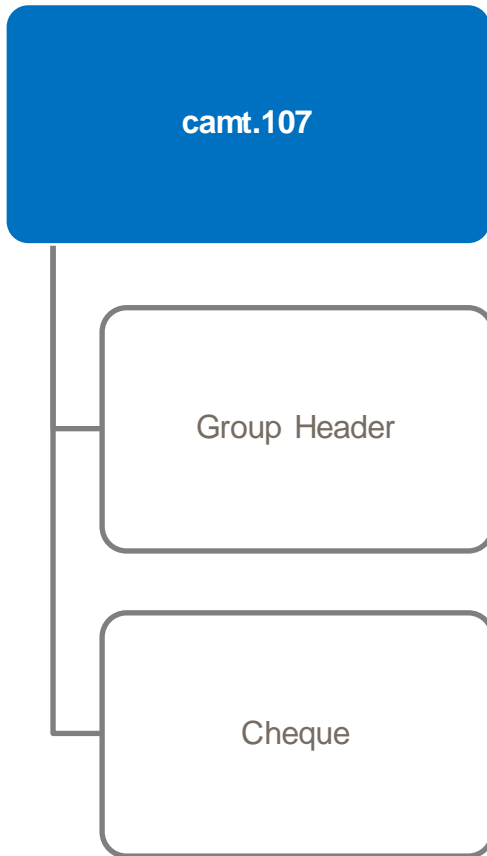

The ChequePresentmentNotification message is sent by a drawer bank, or a bank acting on behalf of the drawer bank to the bank on which a cheque has been drawn (the drawee bank).

It is used to advise the drawee bank, or confirm to an enquiring bank, the details concerning the cheque referred to in the message.



The Cheque Presentment Notification is restricted to a single cheque per InterAct message.

High Level Flows of Cheque Presentment Notification (camt.107)

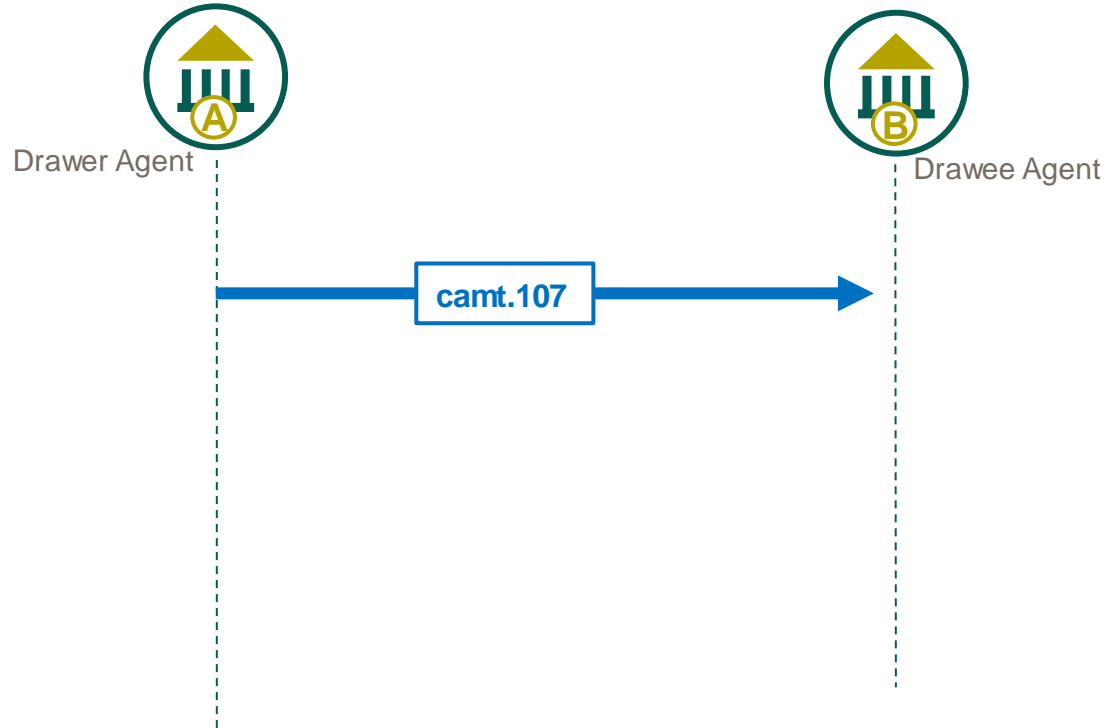

The Agent A (drawer agent) sends a ChequePresentmentNotification message to Agent B (the drawee agent). The ChequePresentmentNotification message informs the drawee agent about the cheque submission. The notification message facilitates the drawee agent to follow up the cheque submission and relevant business process.

Group Header



camt.107 Cheque Presentment Notification - Message Identification

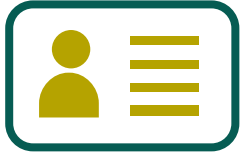

Each ISO 20022 cash management message has a *Message Identification* element, located in the Group Header. This **35 character** identifier is a point-to-point reference used to unambiguously identify the message.

For Cash Management (camt) messages the *Message Identification* has no exact equivalent in the legacy MT Advice of Cheque message. However, the *Sender's Reference* (Field 20) could be considered a similar comparison.

Group Header ➤ Message Identification

camt.107 Cheque Presentment Notification – Creation DateTime

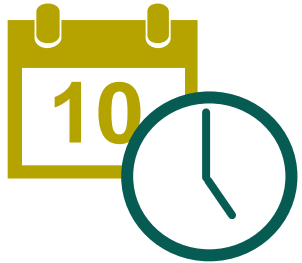

CBPR+ usage guidelines mandate the time zone that the time represents as an offset against Universal Time Coordinated (UTC):

Local time with UTC offset `YYYY-MM-DDThh:mm:ss.sss+/-hh:mm`

- For example: `2002-10-10T12:00:00-05:00` (noon/midday on 10 October 2002, Central Daylight Savings Time as well as Eastern Standard Time in the U.S.)



All CBPR+ time elements need offset against UTC. Milliseconds are optional.

Group Header ▶ Creation Date Time

camt.107 Cheque Presentment Notification – Number Of Cheques

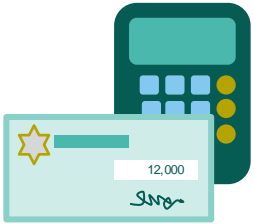

The number of Cheques in CBPR+ cheque payment usage guidelines is fixed to 1.

Group Header ▶ Number Of Cheques



Cheque



camt.107 Cheque Presentation Notification – Cheque

Min 1 – Max 1

The Cheque Presentation Notification *Cheque* nested element specifies the details of the Cheque.



This Cheque element has been restricted to one cheque occurrence.

Cheque



camt.107 Cheque Presentment Notification – Instruction Identification

Min 1 – Max 1

The Cheque Presentment Notification **Instruction Identification** provides an optional element to identify unambiguously the instruction



Point to point reference that can be used between the Agent instructing the Cheque Presentment Notification and the Drawee Agent (Agent receiving this message) to refer to the individual instruction.

Cheque  Instruction Identification

camt.107 Cheque Presentment Notification – Cheque Number

Min 1 – Max 1

The Cheque Number Notification ***Cheque Number*** provides a mandatory element to identify unambiguously the Cheque.



Unique and unambiguous number for a cheque as assigned by the Drawee Agent. This cheque number is often found as part of the Magnetic Ink Character Recognition (MICR) encoding at the bottom of a cheque

Cheque

➤ *Cheque Number*

camt.107 Cheque Presentment Notification – Issue Date and Stale Date

The Cheque Presentment Notification has several elements to capture a Date related to the cheque.



Min 1 – Max 1

The **Issue Date** is a mandatory element, and represents the date when the cheque was issued by the payer, or on behalf of the payer



Min 0 – Max 1

The **Stale Date** is an optional element and represents the date after which a cheque is no longer valid. The validity period of a cheque is calculated from the issue date on the face of the cheque. The period may be indicated on the face of the cheque itself such as "Valid for 90 days" or may be determined in accordance with domestic banking practice. Not all countries will have a validity period.

Cheque 

Issue Date

Stale Date

camt.107 Cheque Presentment Notification – Amount and Value Date



A mandated currency ^{Min 1 – Max 1} **Amount** of the cheque to be paid to the payee.



^{Min 0 – Max 1} The **Value Date** is an optional element, it is used to capture the **Date**, where different to the **Issue Date**, i.e., represents a date on the cheque in the future. The cheque Value Date describes the date in which the cheque amount becomes available to be deposited on the payee account.



The Value Date captured in the camt.107 is referred to as Effective Date in the camt.108 Cheque Cancellation or Stop Request and camt.109 Cheque Cancellation or Stop Report

Cheque >

Amount >

Value Date > Date

camt.107 Cheque Presentment Notification – Payer

Min 1 – Max 1

The Cheque Presentment Notification **Payer** captures the party that instructs the Drawee Agent to issues a cheque to pay a specific amount, upon presentment, to the payee. The Payer sub-element describe the Payer in greater detail.

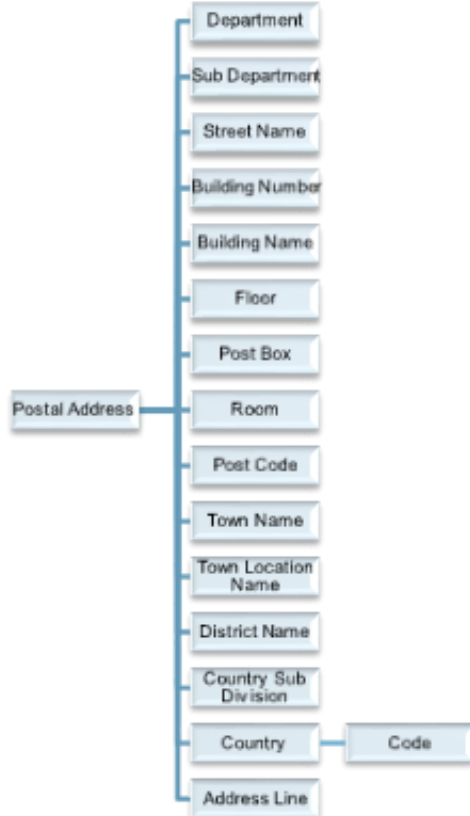

Nested element capturing either structured or unstructured **Payer** address details

Nested element capturing the various types of identifiers for the party e.g. BIC, LEI etc.

Optional element to capture the Payee's ISO country code of residence

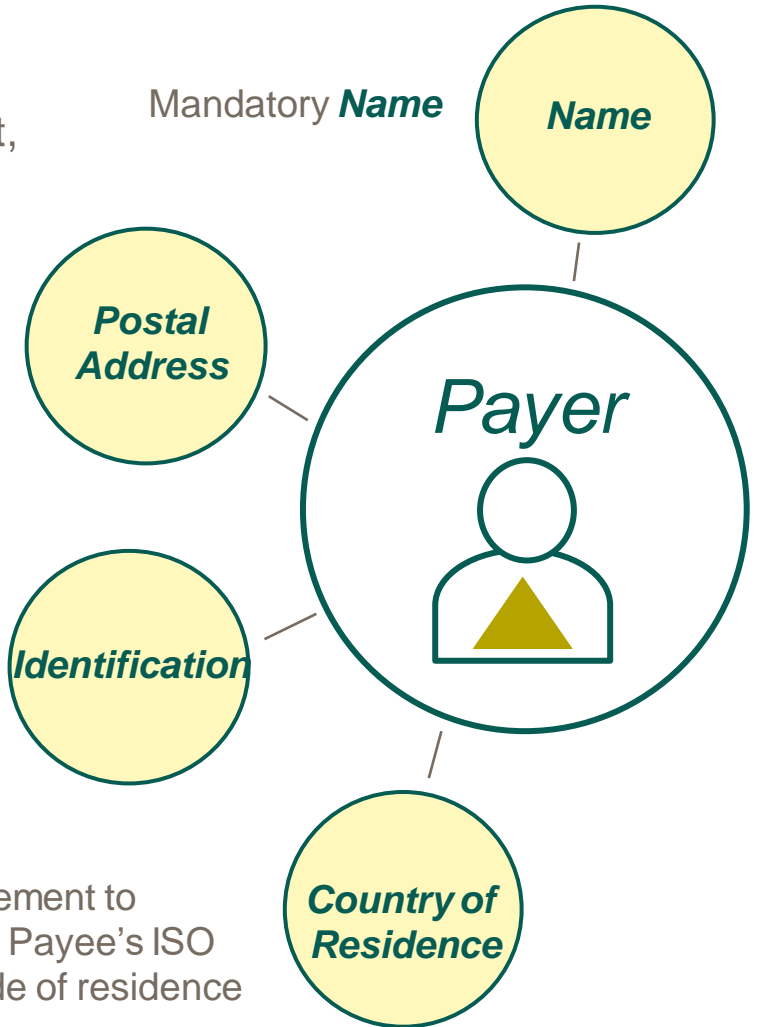

camt.107 Cheque Presentment Notification – Payer Account

Min 0 – Max 1

The Cheque Presentment Notification **Payer Account** is used to capture the account of the party that instructs the Drawee Agent to issues a cheque to pay a specific amount, upon presentment, to the payee.

The **Payer Account** uses a variety of nested elements to capture information related to the account.



Min 0 – Max 1 **Identification** identifies the account maintained at the Drawer Agent (Account Servicing Institution)

Min 0 – Max 1 **Type** uses the external Cash Account Type code list to identify the type of account

Min 0 – Max 1 **Currency** identifies the currency of the account

Min 0 – Max 1 **Name** identifies the name of the account as assigned by the Drawer Agent (Account Servicing Institution)

Min 0 – Max 1 **Proxy** captures an alternative identification of the account number such as an email address. This element has further nested **Type** which is a choice of external code list or proprietary code and **Identification** which are both mandatory where the Proxy element is used.

camt.107 Cheque Presentment Notification – Drawer Agent and Drawer Agent Account



Min 0 – Max 1

The Cheque Presentment Notification **Drawer Agent** optionally captures the Agent who the cheque has been drawn on. This Agent is typically also the Agent from who the Cheque Presentment Notification is sent to the **Drawee Agent**.

Min 0 – Max 1

The **Drawer Agent Account** optionally captures the Drawer Agent's Account with the **Drawee Agent** and who would receive an order the pay the cheque upon presentment.

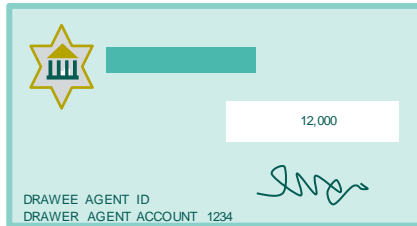

The Drawer Bank is typically identified on the cheque together with their Postal Address. The Drawer Agent's Account with the Drawee Agent is also often also identified on the cheque.

Cheque

Drawer Agent

Drawer Agent Account



camt.107 Cheque Presentment Notification – Payee

Min 1 – Max 1

The Cheque Presentment Notification **Payee** captures the party that should receive an amount of money as specified in the cheque. The Payee sub-element describe the Payee in greater detail.

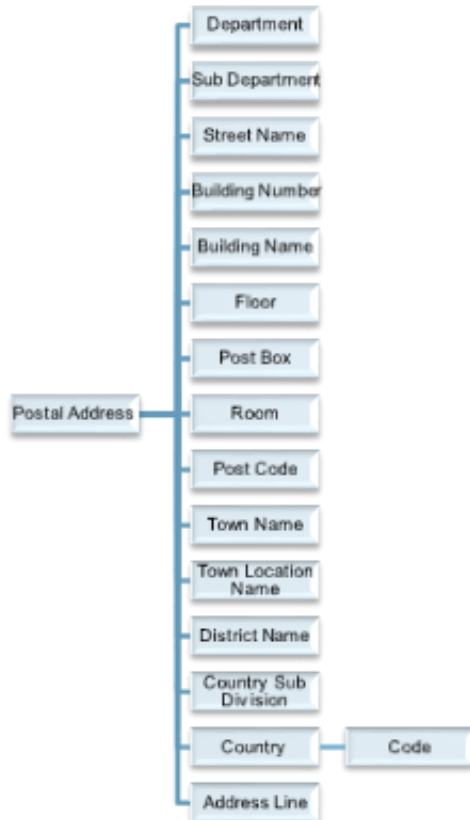

Nested element capturing either structured or unstructured **Payee** address details

Nested element capturing the various types of identifiers for the party e.g. BIC, LEI etc.

Optional element to capture the Payee’s ISO country code of residence

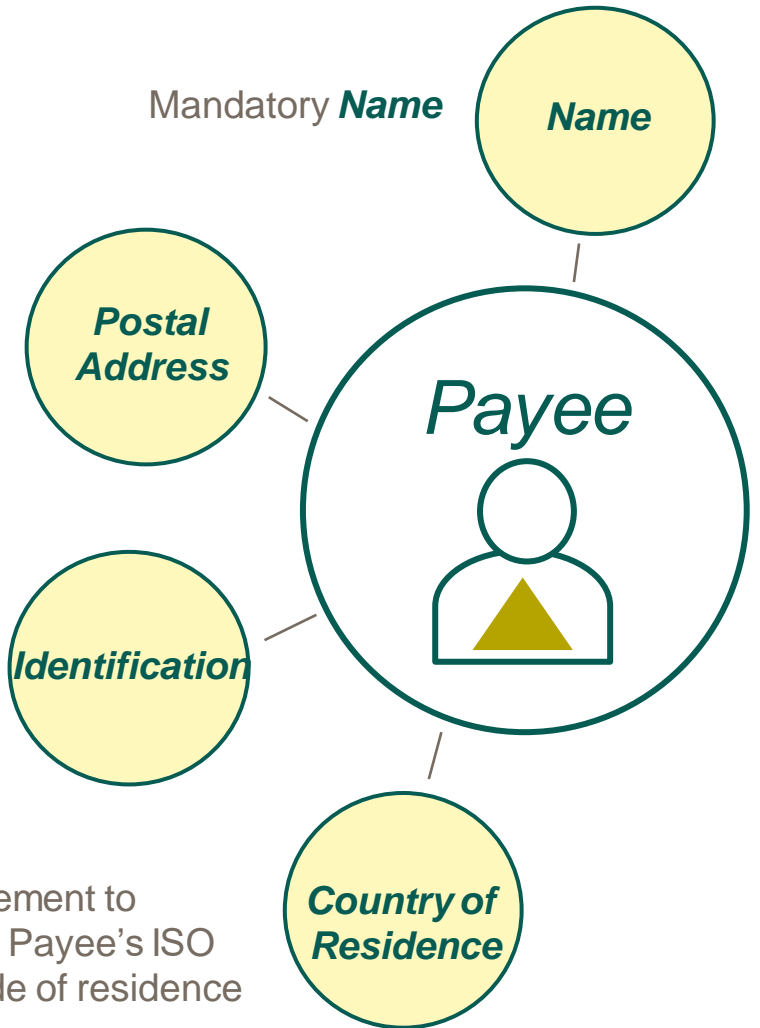

Index of camt.107 Use Cases

Use case should be considered as a principal example whereby use case may be cross referenced e.g. a use case involving a Market Infrastructure can apply the Market Infrastructure legs to other use cases.

Serial Financial Institution to Financial Institution to Customer Credit Transfer

Use Case c.107.1 – High Level Drawer Agent Cheque issuance to Payee, on their account with the Drawer Agent

Use Case c.107.2 - High Level Drawer Agent Cheque issuance to Payee, on their head office's account with the Drawer Agent

High Level Drawer Agent Cheque issuance to Payee, on their account with the Drawee Agent

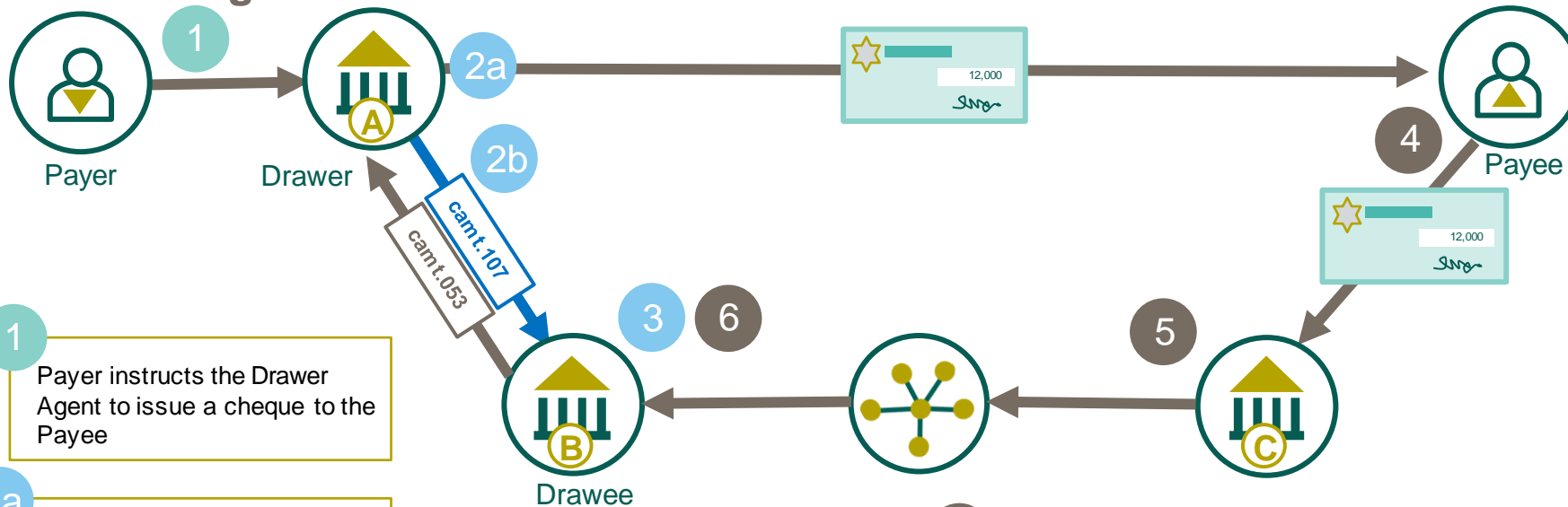

1 Payer instructs the Drawer Agent to issue a cheque to the Payee

2a Drawer Agent (A) issues a cheque to the Payee drawn of their account at the Drawee Agent (B)

2b In parallel the Drawer Agent (A) initiates a Cheque Presentation Notification to the Drawee Agent (B)

3 The Drawee Agent (B) receives the Cheque Presentation Notification and store the information in anticipation for the cheque to be presented

4 Payee received the cheque and present it to their bank (Agent C)

5 Agent C receives the cheque deposit and present it into the domestic cheque clearing

6 Drawee Agent (B) receives the cheque presentation via the cheque clearing. They validate the presented cheque details again the information received on the Cheque Presentation Notification to conclude whether the cheque can be settled.



High Level Drawer Agent Cheque issuance to Payee, on their head office's account with the Drawee Agent

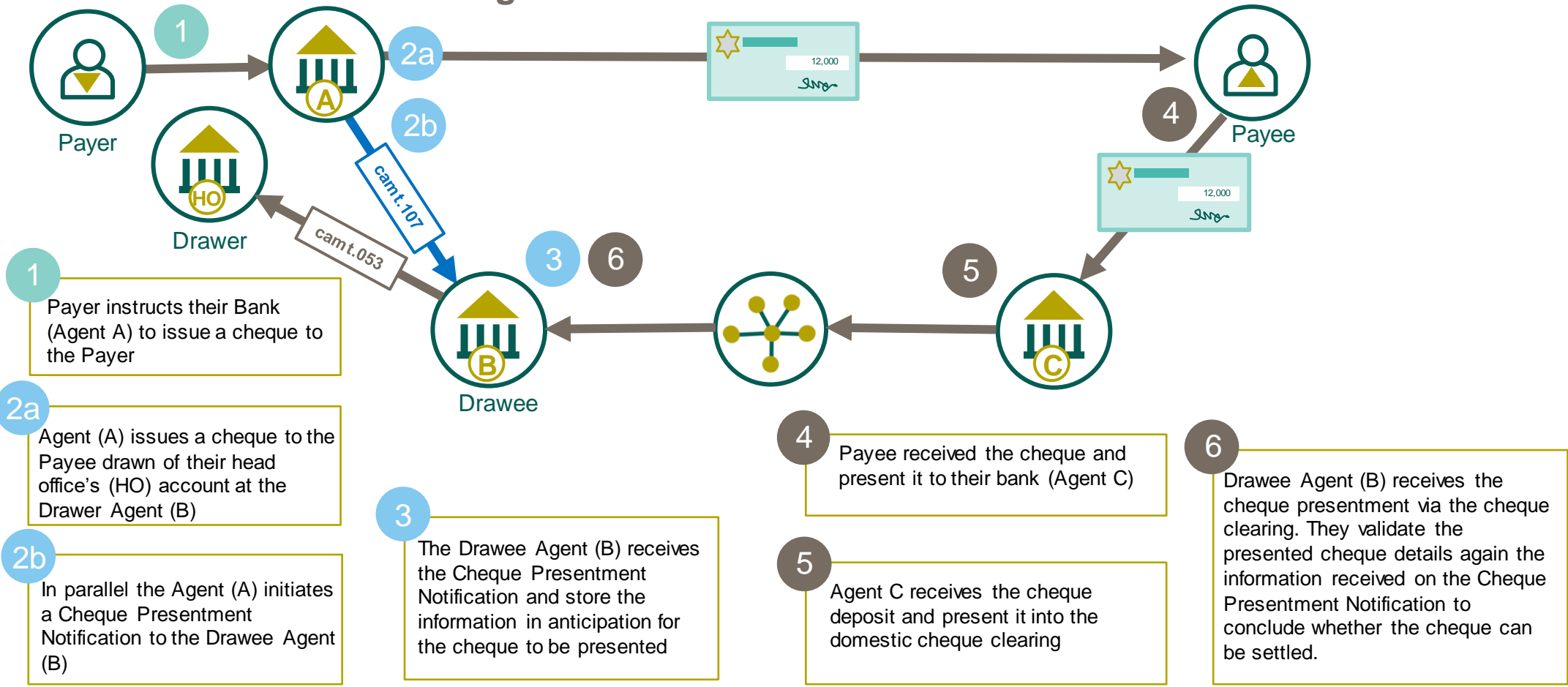



Cheque Cancellation or Stop Request

camt.108 Cheque Cancellation or Stop Request

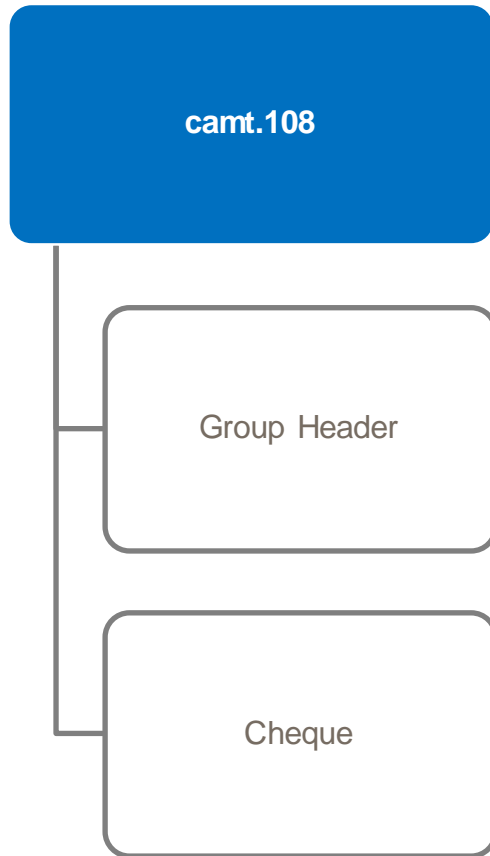

The Cheque Cancellation Or Stop Request message is sent by a drawer bank, or a bank acting on behalf of the drawer bank, to the agent on which a cheque has been drawn (the drawee bank) to request for the cancellation of the presentment and/or stop the payment of the cheque referred to in the message.



The Cheque Cancellation or Stop Report is restricted to a single cheque per InterAct message.

High Level Flows of Cheque Cancellation or Stop Request (camt.108)

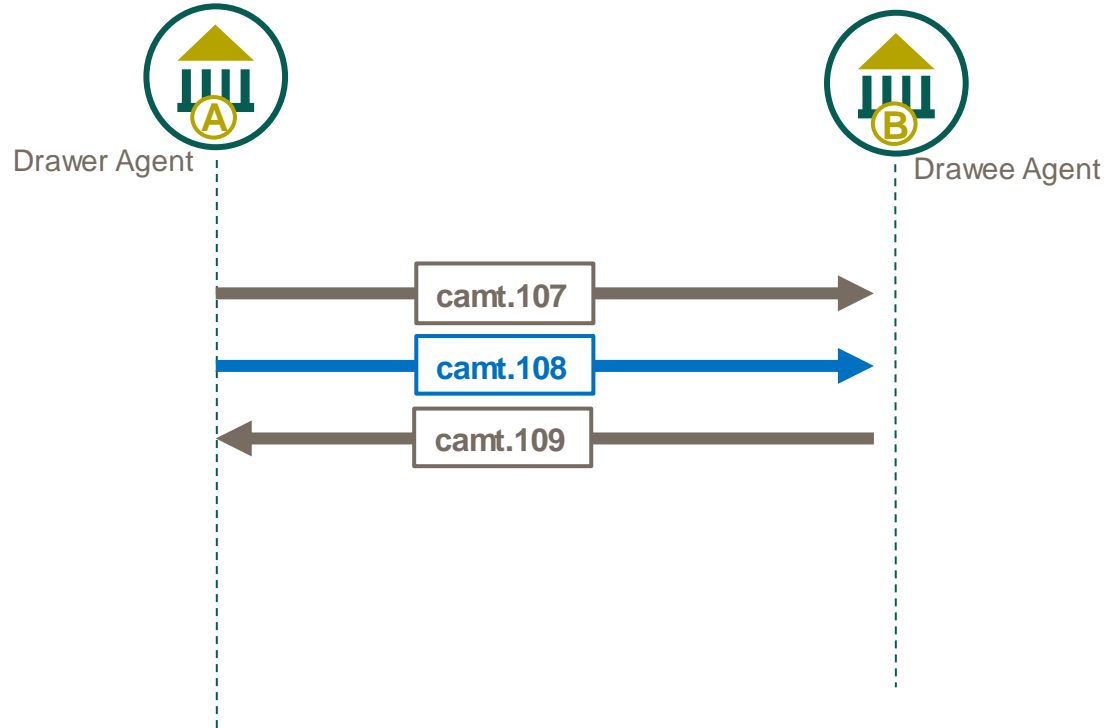

The Agent A (Drawer Agent) sends a ChequeCancellationOrStopRequest message to Agent B (the Drawee Agent). The ChequeCancellationOrStopRequest message requests the drawee agent to place a stop (refusal to settle) upon presentation of the cheque, effectively canceling the issued cheque.

Group Header



camt.108 Cheque Cancellation or Stop Request - Message Identification

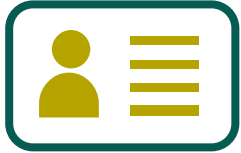

Each ISO 20022 cash management message has a *Message Identification* element, located in the Group Header. This **35 character** identifier is a point-to-point reference used to unambiguously identify the message.

For Cash Management (camt) messages the *Message Identification* has no exact equivalent in the legacy MT Advice of Cheque message. However, the *Sender's Reference* (Field 20) could be considered a similar comparison.

Group Header ➤ Message Identification

camt.108 Cheque Cancellation or Stop Request – Creation DateTime

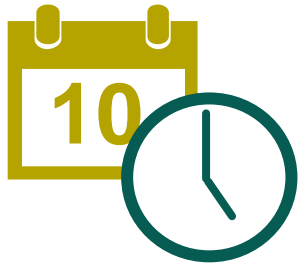

CBPR+ usage guidelines mandate the time zone that the time represents as an offset against Universal Time Coordinated (UTC):

Local time with UTC offset `YYYY-MM-DDThh:mm:ss.sss+/-hh:mm`

- For example: `2002-10-10T12:00:00-05:00` (noon/midday on 10 October 2002, Central Daylight Savings Time as well as Eastern Standard Time in the U.S.)



All CBPR+ time elements need offset against UTC. Milliseconds are optional.

Group Header ▶ Creation Date Time

camt.108 Cheque Cancellation or Stop Request – Number Of Cheques

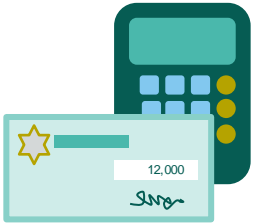

The number of Cheques in CBPR+ cheque payment usage guidelines is fixed to 1.

Group Header ▶ Number Of Cheques

Cheque



camt.108 Cheque Cancellation or Stop Request – Cheque

Min 1 – Max 1

The Cheque Cancellation or Stop Request **Cheque** nested element specifies the details of the Cheque.



This Cheque element has been restricted to one cheque occurrence.

Cheque



camt.108 Cheque Cancellation or Stop Request – Instruction Identification

Min 0 – Max 1

The Cheque Cancellation or Stop Request **Instruction Identification** provides an optional element to identify unambiguously the instruction



Point to point reference that can be used between the Agent instructing the Cheque Cancellation or Stop Request and the Drawee Agent (Agent receiving this message) to refer to the individual instruction.

Cheque  Instruction Identification

camt.108 Cheque Cancellation or Stop Request – Original Instruction Identification

Min 1 – Max 1

The Cheque Cancellation or Stop Request **Original Instruction Identification** provides an optional element to identify unambiguously the original instruction



Point to point reference that can be used to identify the original Cheque Presentment Notification between the Agent instructing the Cheque Presentment Notification and the Drawee Agent (Agent receiving this message) to refer to the individual instruction.

Cheque > Original Instruction Identification

camt.108 Cheque Cancellation or Stop Request – Cheque Number

Min 1 – Max 1

The Cheque Cancellation or Stop Request **Cheque Number** provides a mandatory element to identify unambiguously the Cheque.



Unique and unambiguous number for the cheque as assigned by the Drawee Agent. This cheque number is often found as part of the Magnetic Ink Character Recognition (MICR) encoding at the bottom of a cheque

Cheque  Cheque Number

camt.108 Cheque Cancellation or Stop Request – Issue Date and Stale Date

The Cheque Cancellation or Stop Request has several elements to capture a Date related to the cheque.



Min 1 – Max 1

The **Issue Date** is a mandatory element, and represents the date when the cheque was issued by the payer, or on behalf of the payer



Min 0 – Max 1

The **Stale Date** is an optional element and represents the date after which a cheque is no longer valid. The validity period of a cheque is calculated from the issue date on the face of the cheque. The period may be indicated on the face of the cheque itself such as "Valid for 90 days" or may be determined in accordance with domestic banking practice. Not all countries will have a validity period.

Cheque 

Issue Date

Stale Date

camt.108 Cheque Cancellation or Stop Request – Amount and Value Date



A mandated currency ^{Min 1 – Max 1} **Amount** of the cheque to be paid to the payee.



The ^{Min 0 – Max 1} **Effective Date** is an optional element, it is used to capture the original **Value Date** (as provided in the camt.107), where different to the original **Issue Date**, i.e., represents a date on the cheque in the future. The cheque Value Date describes the date in which the cheque amount becomes available to be deposited on the payee account.

Cheque >

Amount >

Value Date > Date

camt.108 Cheque Cancellation or Stop Request– Drawer Agent and Drawer Agent Account

Min 0 – Max 1

The Cheque Cancellation or Stop Request **Drawer Agent** optionally captures the Agent who the cheque has been drawn on. This Agent is typically also the Agent from who the Cheque Presentment Notification is sent to the **Drawee Agent**.

The **Drawer Agent Account** optionally captures the Drawer Agent's Account with the **Drawee Agent** and who would receive an order the pay the cheque upon presentment.

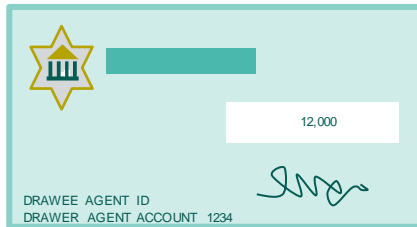

The Drawer Agent and Drawer Account elements where present should match that of the original camt.107 Cheque Presentment Notification.

Cheque 

Drawer Agent

Drawer Agent Account



camt.108 Cheque Cancellation or Stop Request – Payee

Min 0 – Max 1

The Cheque Cancellation or Stop Request **Payee** captures the party that should receive an amount of money as specified in the cheque. The Payee sub-element describe the Payee in greater detail.

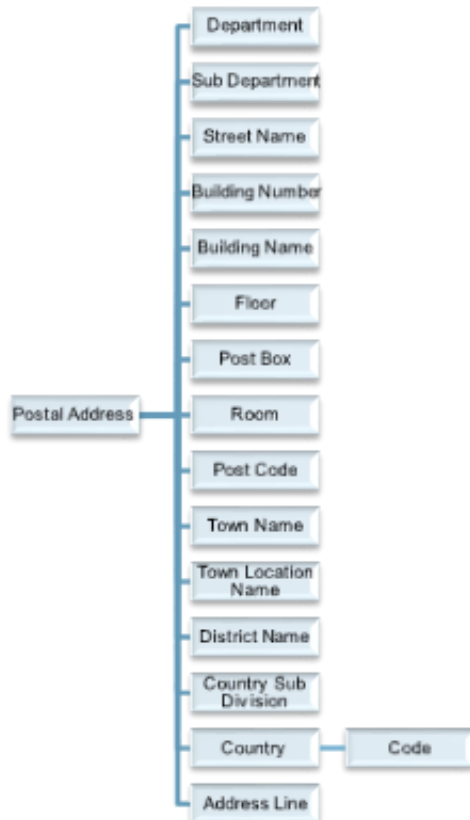

Nested element capturing either structured or unstructured **Payee** address details

Nested element capturing the various types of identifiers for the party e.g. BIC, LEI etc.

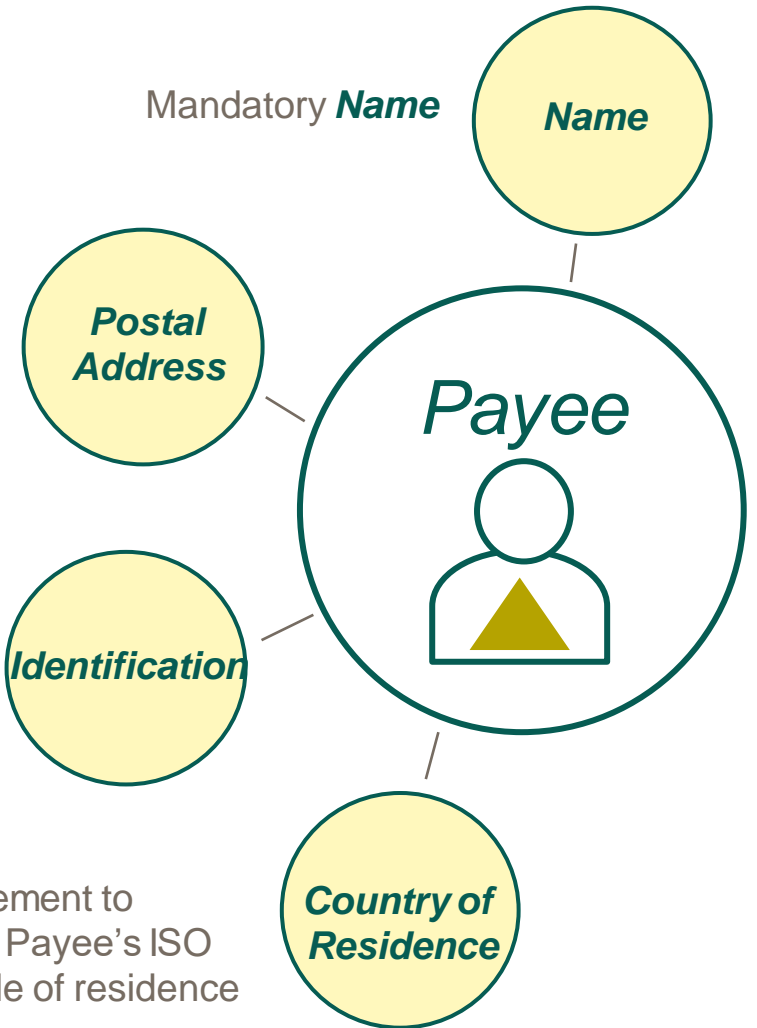

Optional element to capture the Payee's ISO country code of residence



The Payee element where present should match that of the original camt.107 Cheque Presentment Notification.

camt.108 Cheque Cancellation or Stop Request – Cheque Cancellation or Stop

Min 1 – Max 1

The Cheque Cancellation or Stop Request **Cheque Cancellation or Stop Reason** nested element captures information associated with the reason for the Cheque Cancellation or Stop request.

Min 0 – Max 1



the **Originator** element is an embedded code choice that helps identify the party who request the cheque cancellation or stop request. Where used this party would typically be the Payer (code **PAYR**) of the cheque.

Min 1 – Max 1

the **Reason** is mandatory and represented by an embedded CBPR+ Cancellation **Code** choice (↔)

Min 0 – Max 2



the **Additional Information** element may also be included to provide further details on the cancellation or stop reason.



Note where Reason code NARR is used additional information must be provided to describe the reason for the Cheque Cancellation or Stop request.

Cheque ▶ Cheque Cancellation or Stop Reason ✓

▶ Originator

↔ Reason

Additional Information

Index of camt.108 Use Cases

Use case should be considered as a principal example whereby use case may be cross referenced e.g. a use case involving a Market Infrastructure can apply the Market Infrastructure legs to other use cases.

Serial Financial Institution to Financial Institution to Customer Credit Transfer

Use Case c.108.1 – High Level Drawer Agent Cheque Cancellation or Stop request as a result of a lost cheque

Use Case c.108.2 – High Level Drawer Agent Cheque Cancellation or Stop request upon request of the Payer customer.

High Level Drawer Agent Cheque Cancellation or Stop request as a result of a lost cheque.

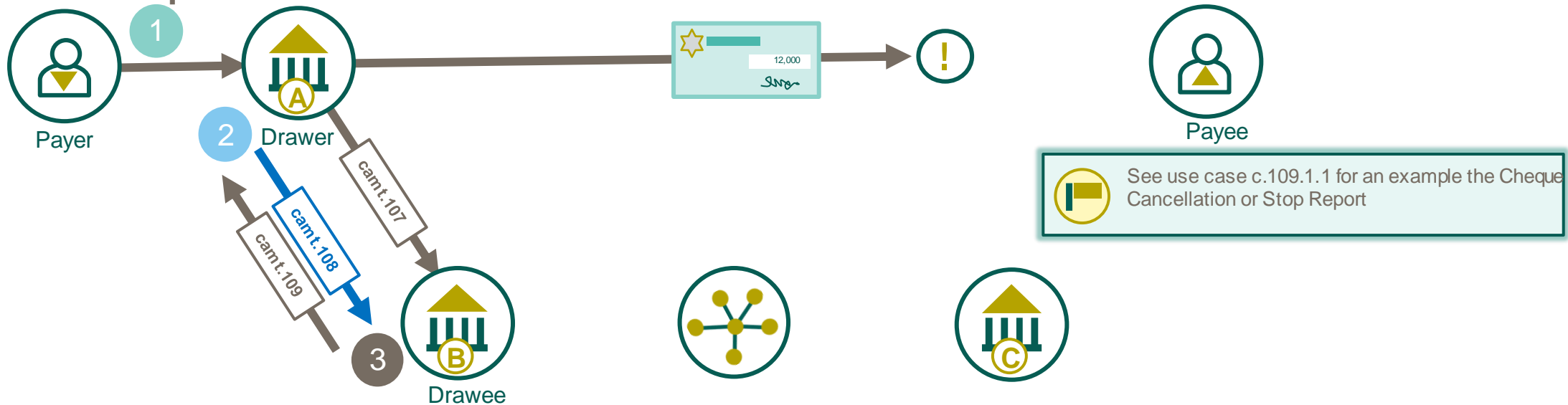

1 Payer instructs the Drawer Agent they wish to cancel or stop a previously issued cheque, as the Payee informs them the cheque has been lost.

2 Drawer Agent (A) issues a cheque cancellation or stop request to the Drawee Agent (B) with reason code LOST

3 Drawee Agent (B) match the request to the previous Cheque Presentment Notification (camt.107). As the cheque has not been presented the status record is identified as not to be paid if presented, as a result of a cancellation/stop request. This is reported back to the Drawer Agent (A) as accepted.

High Level Drawer Agent Cheque Cancellation or Stop request upon request of the Payer customer.

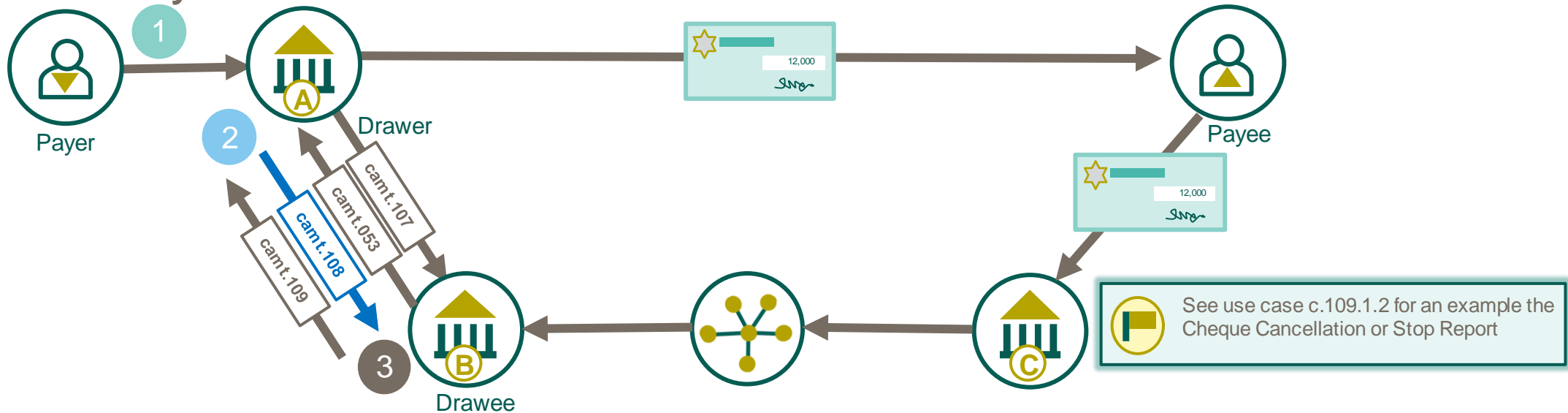

See use case c.109.1.2 for an example the Cheque Cancellation or Stop Report

1 Payer instructs the Drawer Agent they wish to cancel or stop a previously issued cheque, as the Payer informs them they no longer wish to honour the cheque.

2 Drawer Agent (A) issues a cheque cancellation or stop request to the Drawee Agent (B) with reason code CUST

3 Drawee Agent (B) match the request to the previous Cheque Presentment Notification (camt.107). As the cheque has already been presented and paid the cancellation/stop request can not be executed. This is reported back to the Drawer Agent (A) as rejected with additional information to explain the cheque has already been paid.





Cheque Cancellation or Stop Report

camt.109 Cheque Cancellation or Stop Report

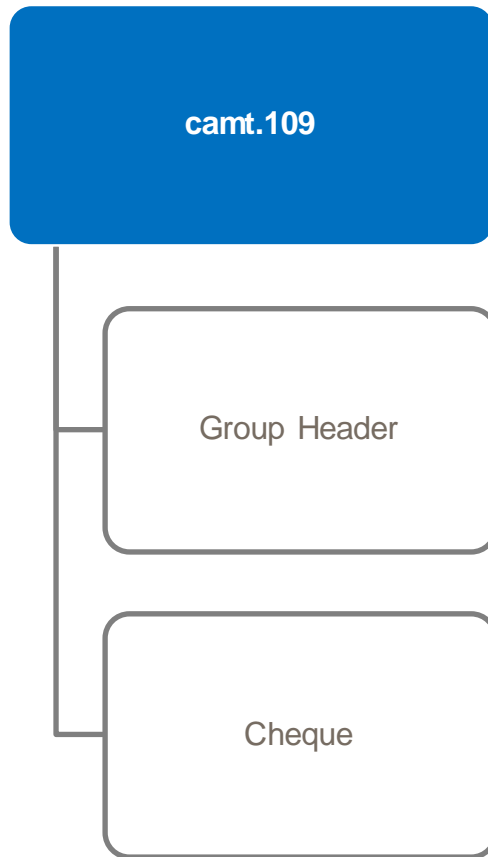

The Cheque Cancellation or Stop Report message is sent by the drawee agent (on which a cheque is drawn) to the drawer agent, or the agent acting on behalf of the drawer agent, to indicate what actions have been taken in attempting to cancel the presentment and/or stop the payment of the cheque referred to in the message.



The Cheque Cancellation or Stop Request is restricted to a single cheque per InterAct message.

High Level Flows of Cheque Cancellation or Stop Report (camt.109)

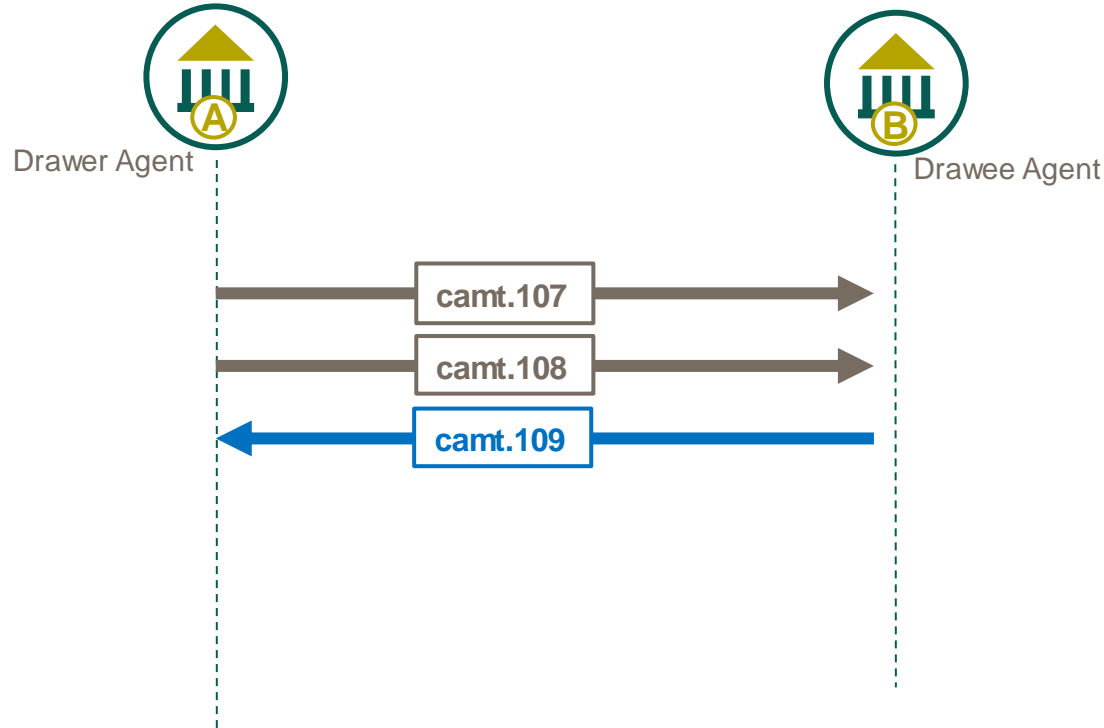

The Agent B (Drawee Agent) sends a `ChequeCancellationOrStopReport` message to Agent A (the Drawer Agent). The `ChequeCancellationOrStopReport` message reports the outcome of a Cheque Cancellation or Stop Request.

Group Header



camt.109 Cheque Cancellation or Stop Report - Message Identification

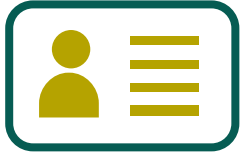

Each ISO 20022 cash management message has a *Message Identification* element, located in the Group Header. This **35 character** identifier is a point-to-point reference used to unambiguously identify the message.

For Cash Management (camt) messages the *Message Identification* has no exact equivalent in the legacy MT Advice of Cheque message. However, the *Sender's Reference* (Field 20) could be considered a similar comparison.

Group Header ➤ Message Identification

camt.109 Cheque Cancellation or Stop Report – Creation DateTime

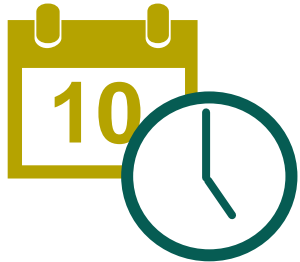

CBPR+ usage guidelines mandate the time zone that the time represents as an offset against Universal Time Coordinated (UTC):

Local time with UTC offset `YYYY-MM-DDThh:mm:ss.sss+/-hh:mm`

- For example: `2002-10-10T12:00:00-05:00` (noon/midday on 10 October 2002, Central Daylight Savings Time as well as Eastern Standard Time in the U.S.)



All CBPR+ time elements need offset against UTC. Milliseconds are optional.

Group Header ▶ Creation Date Time

camt.109 Cheque Cancellation or Stop Report – Number Of Cheques

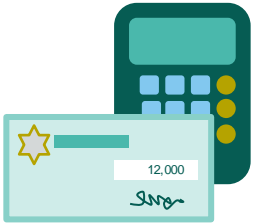

The number of Cheques in CBPR+ cheque payment usage guidelines is fixed to 1.

Group Header ▶ Number Of Cheques

Cheque



camt.109 Cheque Cancellation or Stop Report – Cheque

Min 1 – Max 1

The Cheque Cancellation or Stop Report **Cheque** nested element specifies the details of the Cheque.



This Cheque element has been restricted to one cheque occurrence.

Cheque



camt.109 Cheque Cancellation or Stop Report – Instruction Identification

Min 0 – Max 1

The Cheque Cancellation or Stop Report **Instruction Identification** provides an optional element to identify unambiguously the instruction



Point to point reference that can be used between the Drawee Agent providing the Cheque Cancellation or Stop Report and the Drawee Agent (Agent receiving this message) to refer to the individual instruction.

Cheque  Instruction Identification

camt.109 Cheque Cancellation or Stop Report – Original Instruction Identification

Min 1 – Max 1

The Cheque Cancellation or Stop Request **Original Instruction Identification** provides an optional element to identify unambiguously the original instruction



Point to point reference that can be used to identify the original Cheque Cancellation or Stop Request between the Agent instructing the Cheque Presentment Notification and the Drawee Agent (Agent receiving the request message) to refer to the individual request.

Cheque > Original Instruction Identification

camt.109 Cheque Cancellation or Stop Report – Cheque Number

Min 1 – Max 1

The Cheque Cancellation or Stop Request **Cheque Number** provides a mandatory element to identify unambiguously the Cheque.



Unique and unambiguous number for the cheque as assigned by the Drawee Agent. This cheque number is often found as part of the Magnetic Ink Character Recognition (MICR) encoding at the bottom of a cheque

Cheque  Cheque Number

camt.109 Cheque Cancellation or Stop Report – Issue Date and Stale Date

The Cheque Cancellation or Stop Report has several elements to capture a Date related to the cheque.



Min 1 – Max 1

The **Issue Date** is a mandatory element, and represents the date when the cheque was issued by the payer, or on behalf of the payer



Min 0 – Max 1

The **Stale Date** is an optional element and represents the date after which a cheque is no longer valid. The validity period of a cheque is calculated from the issue date on the face of the cheque. The period may be indicated on the face of the cheque itself such as "Valid for 90 days" or may be determined in accordance with domestic banking practice. Not all countries will have a validity period.

Cheque 

Issue Date

Stale Date

camt.109 Cheque Cancellation or Stop Report – Amount and Value Date



A mandated currency ^{Min 1 – Max 1} **Amount** of the cheque to be paid to the payee.



The ^{Min 0 – Max 1} **Effective Date** is an optional element, it is used to capture the original **Value Date** (as provided in the camt.107), where different to the original **Issue Date**, i.e., represents a date on the cheque in the future. The cheque Value Date describes the date in which the cheque amount becomes available to be deposited on the payee account.

Cheque >

Amount >

Value Date > Date

camt.109 Cheque Cancellation or Stop Report – Drawer Agent and Drawer Agent Account

Min 0 – Max 1

The Cheque Cancellation or Stop Request **Drawer Agent** optionally captures the Agent who the cheque has been drawn on. This Agent is typically also the Agent from who the Cheque Presentment Notification is sent to the **Drawee Agent**.

The **Drawer Agent Account** optionally captures the Drawer Agent's Account with the **Drawee Agent** and who would receive an order the pay the cheque upon presentment.

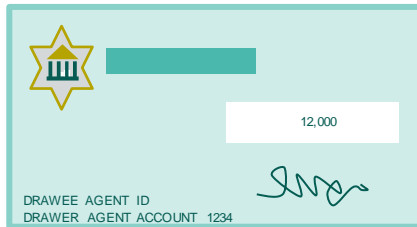

The Drawer Agent and Drawer Account elements where present should match that of the original camt.107 Cheque Presentment Notification.

Cheque 

Drawer Agent

Drawer Agent Account



camt.109 Cheque Cancellation or Stop Report – Payee

Min 0 – Max 1

The Cheque Cancellation or Stop Request **Payee** captures the party that should receive an amount of money as specified in the cheque. The Payee sub-element describe the Payee in greater detail.

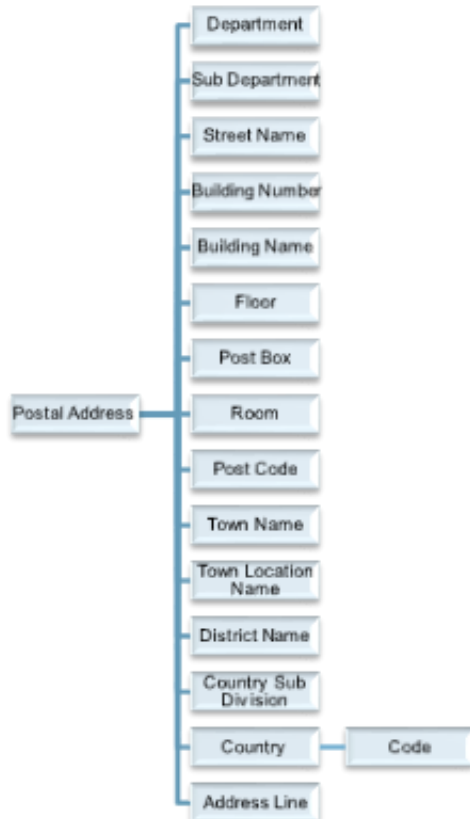

Nested element capturing either structured or unstructured **Payee** address details

Nested element capturing the various types of identifiers for the party e.g. BIC, LEI etc.

Optional element to capture the Payee’s ISO country code of residence

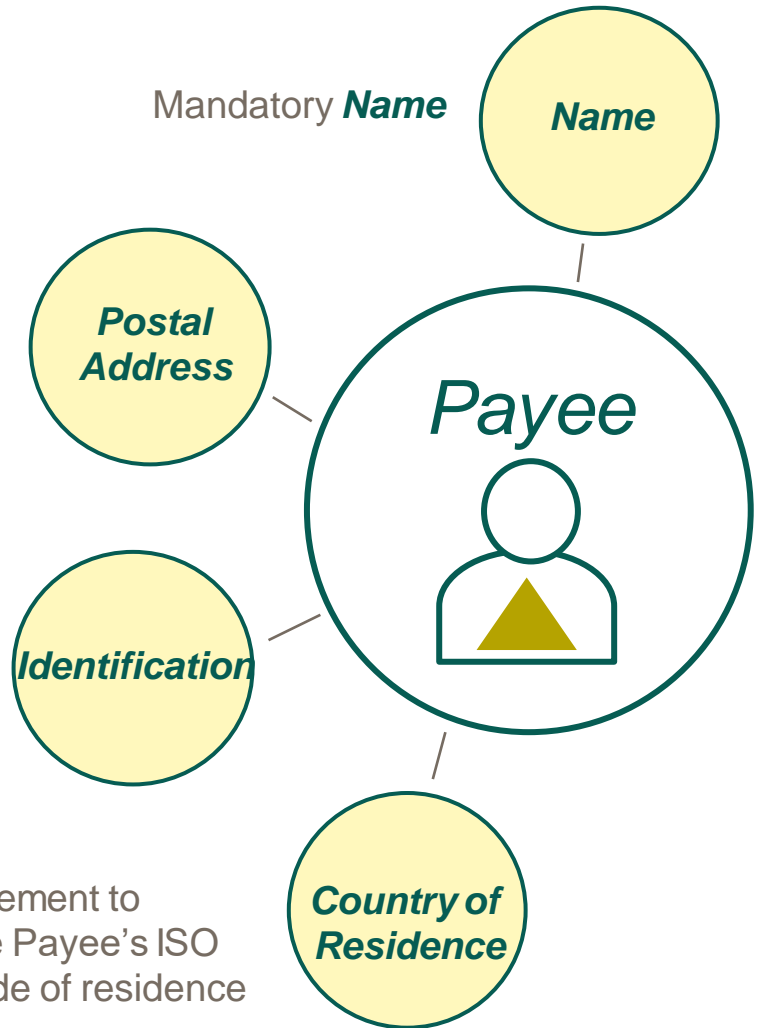

The Payee element where present should match that of the original camt.107 Cheque Presentment Notification.

camt.109 Cheque Cancellation or Stop Report – Cheque Cancellation or Stop Reason

Min 1 – Max 1

The Cheque Cancellation or Stop Request **Cheque Cancellation or Stop Reason** nested element captures information associated with the reason for the Cheque Cancellation or Stop request.

Min 0 – Max 1

the **Originator** element helps identify the party who request the cheque cancellation or stop request. Where used this party would typically be the Payer of the cheque.

Min 1 – Max 1

the **Status** is mandatory and represented by an embedded status **Code** choice (↔)
REJT (Rejected) or ACCP (Accepted)

Min 0 – Max 2

the **Additional Information** element may also be included to provide further details on the cancellation or stop reason.



Note where Status code REJT is used additional information must be provided to describe the reason for the rejection.

Cheque ▶ Cheque Cancellation or Stop Reason ✓

▶ Originator

⊗ Reason

Additional Information

Index of camt.109 Use Cases

Use case should be considered as a principal example whereby use case may be cross referenced e.g. a use case involving a Market Infrastructure can apply the Market Infrastructure legs to other use cases.

Serial Financial Institution to Financial Institution to Customer Credit Transfer

Use Case c.109.1 – High Level Drawer Agent Cheque Cancellation or Stop request as a result of a lost cheque

Use Case c.109.2 – High Level Drawer Agent Cheque Cancellation or Stop request upon request of the Payer customer.

High Level Drawer Agent Cheque Cancellation or Stop report as a result of a lost cheque.

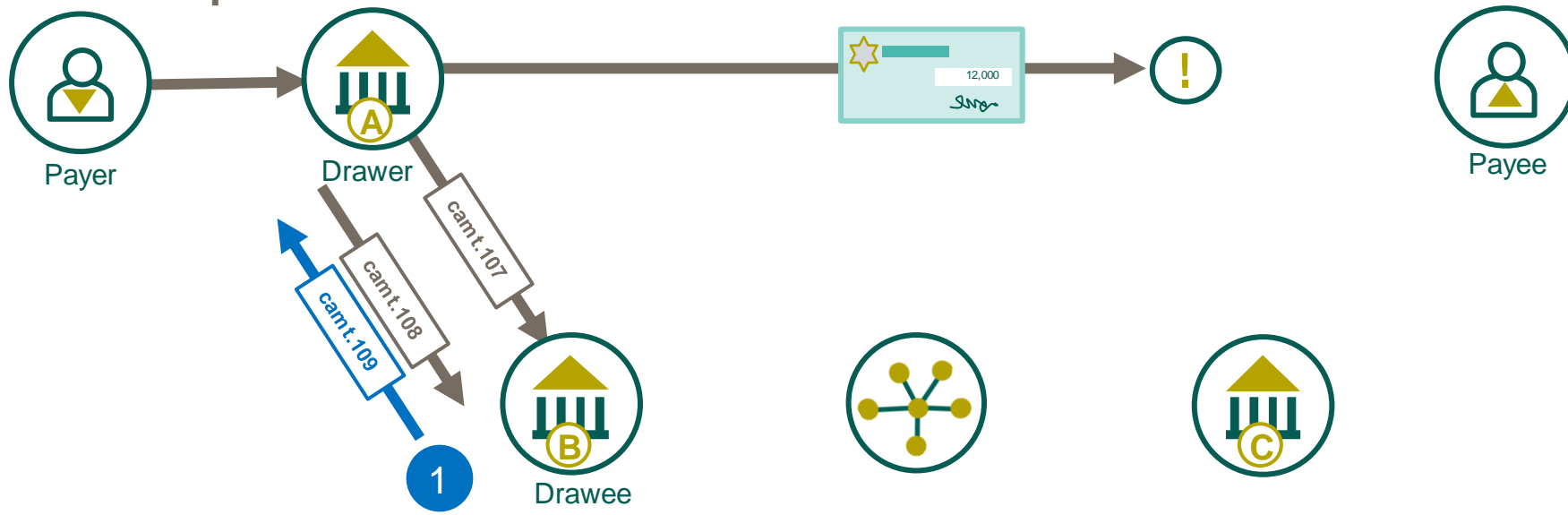

1 Drawee Agent (B) reports to the Drawer Agent (A) that the Cheque Cancellation or Stop request has been accepted.

See use case c.108.1.1 for an example the Cheque Cancellation or Stop Request

High Level Drawer Agent Cheque Cancellation or Stop report upon request of the Payer customer.

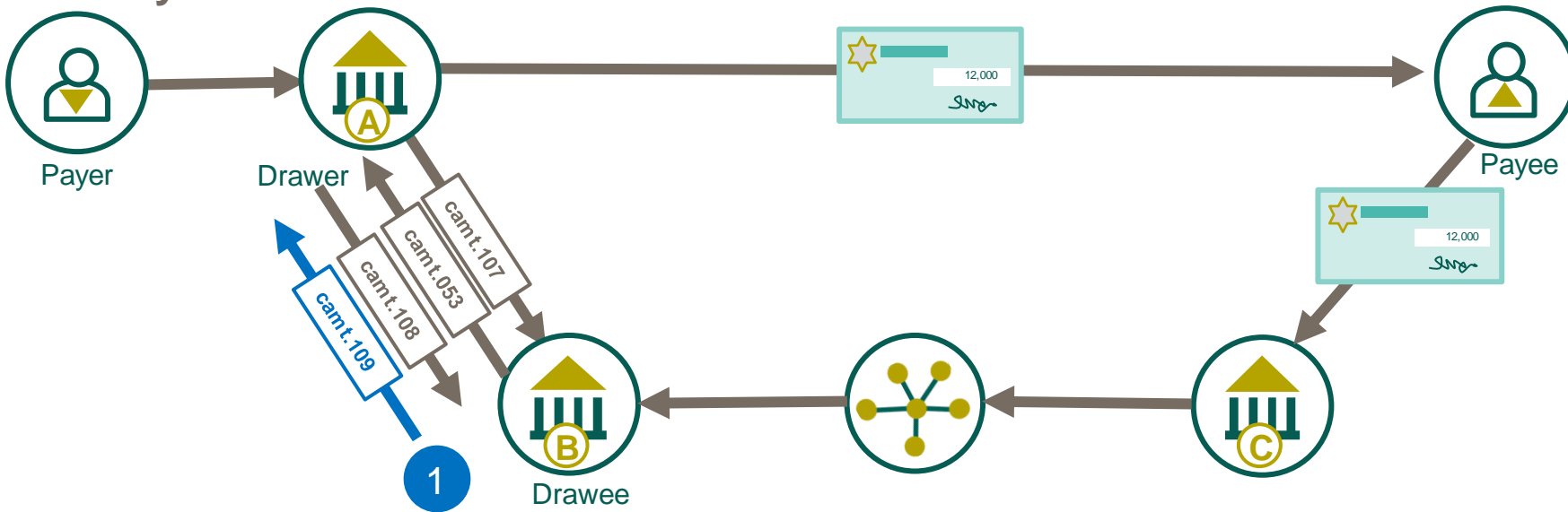

1 Drawee Agent (B) reports to the Drawer Agent (A) that the Cheque Cancellation or Stop request has been rejected. Additional Information is provided to explain that the cheque has already been presented and paid.

See use case c.108.1.2 for an example the Cheque Cancellation or Stop Request



www.swift.com