

# SCP-3

## Electronic Controller

**OXIGEN** Ready 2.4GHz  
SLOT.IT DIGITAL  
wireless software updates



Battery NOT included  
Compatible with ALL SCP Cartridges  
Compatible with Scalextric AIR/PRO  
(requires wireless software updates)

## ACTIVATE THE SCP-3 BEFORE USE

Thank you for your purchase. Before ANY further action, the SCP-3 must be ACTIVATED with the Slot.it APP. Without activation the SCP-3 will not work. What is the activation? Very simply, via Bluetooth, the APP reads the network ID (known as MAC) of the controller, writes permanently the current date in the SCP-3 memory, and saves the following data: your email, the controller MAC, the activation date, the firmware version, and the device name in a cloud database that we can access. The same data is available on the APP.

The activation date is the date used for warranty. Regardless of when you bought the controller, and of availability of the purchase receipt, we consider a two years period from the day you actually start using your device – which is the activation date.

You must give a name to the controller, which is quite useful thing to do if you have more than one.

As we develop the APP further, it will become an indispensable companion to the SCP-3, extending its capabilities, with more advanced features becoming available.

The app is also the tool used to update the firmware of your controller to the latest version, or to switch to a different one – you can easily reprogram the SCP3 from being an oXigen controller to a to a Scalextric ARC AIR/PRO and viceversa.

*Note: the APP display has been condensed to fit inside these paper sheets.*

How to activate the SCP-3:



1. Search for oXigen in the APP store. Don't search for Slot.it unless you want get a darn slot machine game. Sownload and install the Slot.it APP on your Android (Android 7.0 or greater) or iOS device. Make sure the geographic location is turned on. This is need by Android Bluetooth function, we don't use such data.
2. Register yourself (email necessary) to access the APP. Enter your email, and touch 'Request Access Code'. The APP sends a confirmation email is sent to your address: copy the code from your inbox, and enter it into the app in the 'Access Code' field. Now press the 'User Login' button that has just appeared

3. Power on the SCP3. Remember, the SCP3 comes with an ON/OFF/Curve selector switch on the back of the controller. Look at the display – the moving message is telling you to **“LAUnCH tHE APP And Add tHE SCP3 – PreSS AnY button to StArt”**
4. Press any button on the SCP3 (example: the big friendly **Parie** Brake button) for two seconds, and the display shows 'hn'. 'hn' is the short form for 'handle', that is, the **handle** part of the SCP3. Now it's time to use the Slot.it APP.

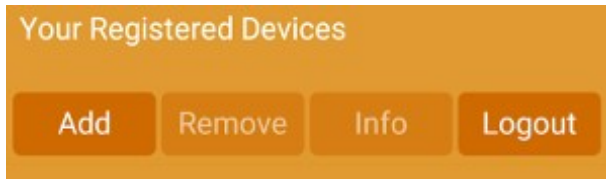

5. So launch the APP (you've done that already if you've followed steps 1. and 2. ), login if necessary, then click 'Add'

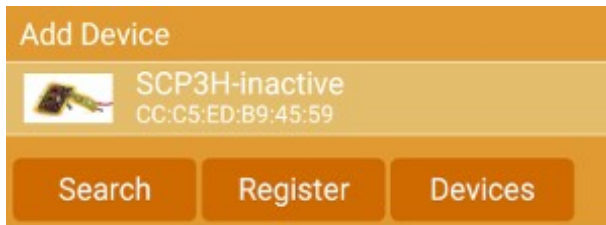

6. The APP searches for the SCP3 for a while (you will notice a circle in the middle of the screen), then when the SCP3 is detected, it appears on screen. Click on 'Register'

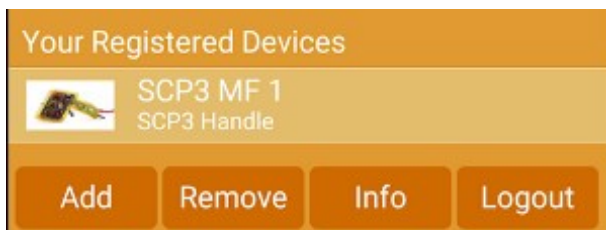

7. You are now ready to use your SCP3



8. Click on 'info' to see your controller's data. Name can be changed with the 'change' button, firmware updated with DFU, and for the immediate future you can ignore the 'buy' button as it is inactive.

## INSTALLATION OF THE OPTIONAL POWER AMPLIFIED MODULE

The SCP-3 provides space for an extra system-on-a-chip in the form of a single radio module with integrated power amplification (Power Amplifier Module, PAM). The module provides the extra power needed to reach very long distances, such as those encountered during indoor racing in rooms like gyms, auditoriums, and the like. The installation of the PAM is optional.

### WHAT'S INSIDE

Inside the packaging there is the module itself, and a plastic support with peel off sticker.

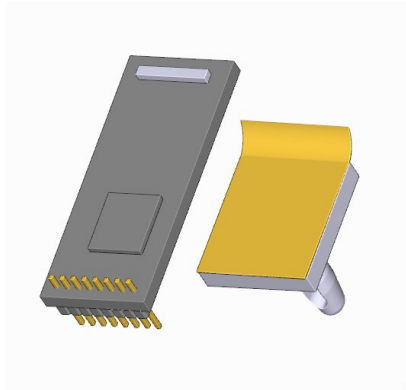

### INSTALLATION

1 - With a Torx T3 wrench (Slot.it PA66 or equivalent), remove the four Torx mini grub screws that secure the red lid to the back of the controller, then remove the red lid to expose the inside PCB, as explained in the picture to the right.

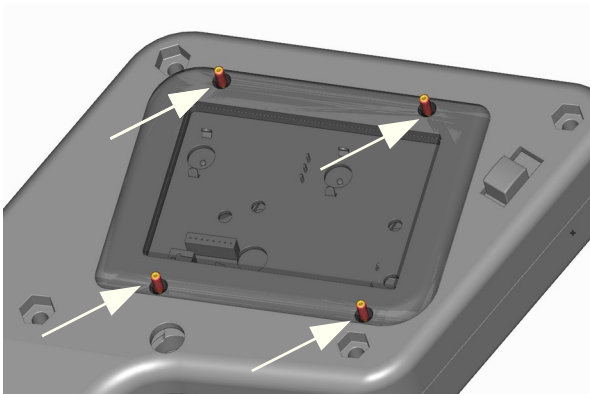

2 - The black arrow in the picture below indicates the hole where the power amplifier support must go:

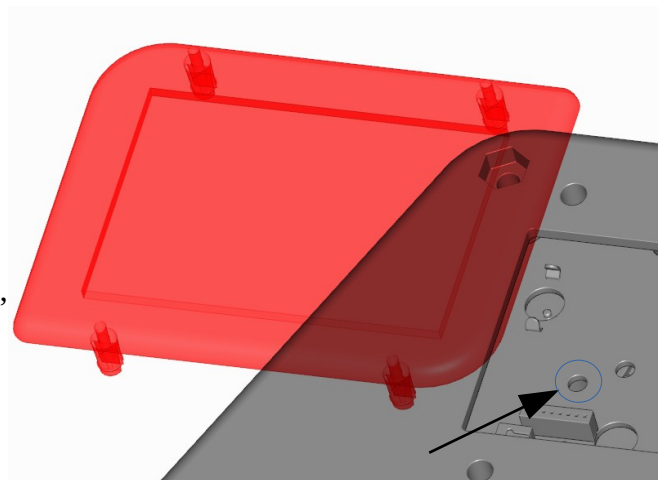

3 - When the support is fully inserted in the hole, it will click and stay there. Insert the support in the hole until it clicks! Now peel off the yellow sticker 'skin'.

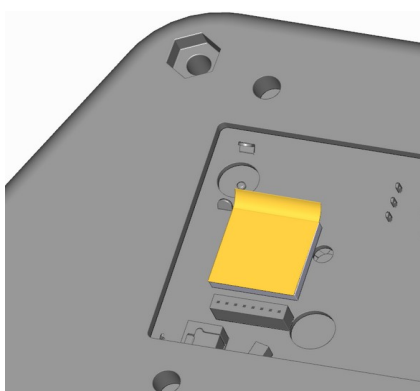



4 - Now it's time to insert the module into place. The module is connected with eight pins that must match the eight holes on the female connector. Make sure that the male pins on the module are aligned to the 8 holes in the receptacle:

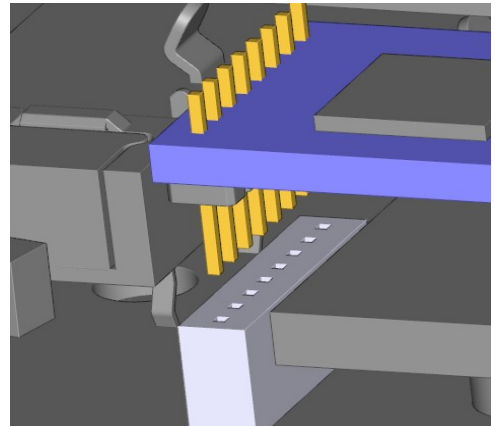
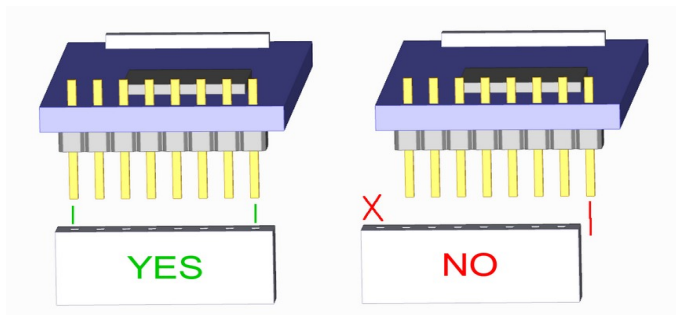

5 - Now you're done and it's time to put your SCP-3 together again:

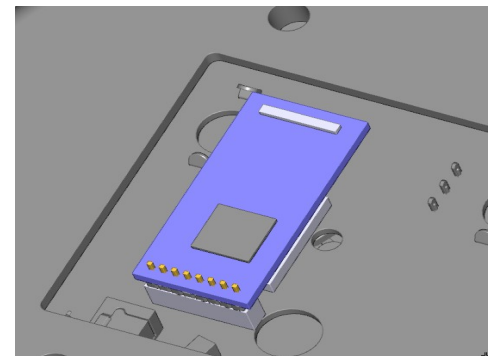
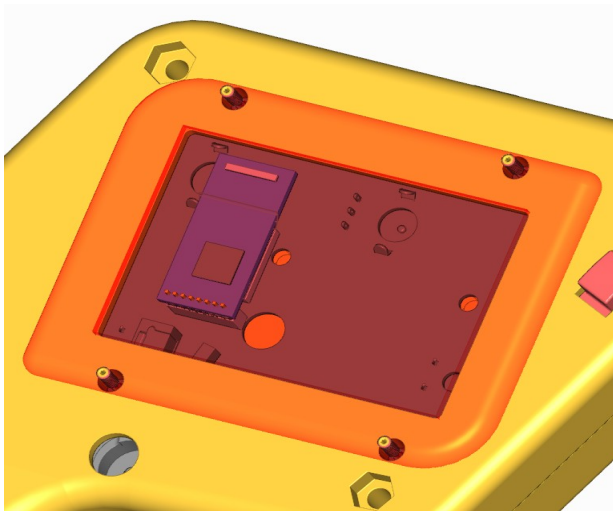

## ACTIVATION

6 - the next step is to **ACTIVATE** the SCP-3 module's firmware.

We assume at this point, because you already have the SCP-3 and have activated it following the instructions that came with it, that you're familiar with the Slot.it APP and the activation procedure. The Power Module is not any different: A summary of the necessary operations is herein:

Switch on the SCP3 with **BOTH ARROWS** pressed. On display, a fixed message shows

**APP - SELECT hAndLE or PA CHIP -**

(or **AP** only , if you have the very early version of the firmware). This means that the SCP3 is ready to connect to the APP or switch control to the Power Amplifier (PA). To connect to the module, press the UP ARROW. Display shows

**PA CHIP**

Confirm pressing the round 'brake' button. The message shows (fixed)

**PA**

Now the PA module can be reached with the APP and activated.

## The SCP3 at power ON

The SCP3 can be switched OFF with the sliding switch on the back. It's a three position switch which also serves to select the response mode between 'curve' and 'linear'. (Needs photo)

Therefore the controller can be easily switched on and off at will, and can do different things depending on whether it is turned on with or without some buttons pressed.

**STANDARD MODE** power on: just switch it on without pressing any buttons. If the controller was already activated, then just drive your car. If it wasn't active, and you see a moving message inviting you to launch the APP, please refer to the previous section of this manual (activation).

**APP MODE** power on: to connect to the APP via Bluetooth, switch on the SCP3 with BOTH ARROWS pressed. On display, a moving message shows

**APP - SELECT hAndLE or PA CHIP -**

As the SCP3 may have or not a power amplifier unit (PA), you must connect either that, or the handle (main controller) to the APP. Select HANDLE with DOWN ARROW, or POWER AMP MODULE with UP ARROW. Display shows either

**hAndLE -** or **PA CHIP -**

You can switch back and forth, until you confirm with the round 'brake' button. The message shows (fixed) either

**hn** or **PA**

Now the SCP3, handle or PA module, can be reached with the APP.

**DFU MODE** power on: DFU means 'direct firmware upgrade'. This is seldom used, as we suggest to use the APP (APP mode) to start DFU. However, it may be useful. To enter DFU mode switch on the SCP3 with BRAKE pressed. On display, a moving message shows

**dfu - SELECT hAndLE or PA CHIP -**

Again, the SCP3 may have or not a power amplifier unit (PA), you must select either that, or the handle (main controller) for firmware upgrade. Select HANDLE with DOWN ARROW, or POWER AMP MODULE with UP ARROW. Display shows either

**hAndLE -** or **PA CHIP -**

You can switch back and forth, until you confirm with the round 'brake' button. The message shows (fixed) either

**hn** or **PA**

Now the SCP3, handle or PA module, can be reprogrammed directly. Note that during the firmware update, it is normal to see funny characters appear on the display.

**BOOTLOADER MODE** power on: the bootloader is a special PC program that communicates, via the oXigen dongle, with the SCP3. To enter this mode, switch on the SCP3 with UP ARROW and BRAKE button pressed. A

**U**

appears on the display. At this point you should be familiar with the usual Bootloader procedures. Note that if you choose to upgrade firmware through the Bootloader, then the Nordic APP (and not the Slot.it APP) should be used to perform the upgrade

**DFU EMERGENCY MODE** power on: if you happen to have loaded the wrong firmware inside the controller, press the DOWN ARROW and switch ON the controller. Ignore anything that may happen on the display: the controller now is in DFU mode and the firmware can be loaded again with either Nordic's app or our own.

*(At this point I was about to write 'refer to the relevant information about firmware upload in the "Updating firmware" section of the manual' when I realized that the entire section was missing from the manual...) So keep on reading!*

## Updating Firmware – basics

To perform a firmware upgrade, the SCP-3 must be in **DFU mode (Direct Firmware Update)**.

The operation may be performed via the Slot.it app, or Nordic's DFU app.

DFU mode can be started by any of the methods described in the 'SCP-3 at power on' section, or by the Bootloader (which hands control to the Nordic app). Read below to understand why and how.

When in DFU mode, a Bluetooth Low Energy (BLE) communication link is established between the controller and the phone. When you ask the app to upgrade the firmware, the app informs the chip inside the controller, the app then fetches the firmware from our web site and starts the DFU procedure.

Firmware can be upgraded only when the controller is in DFU mode.

If you are unsure, go back to the 'SCP-3 at power on' section to learn how to set the controller in DFU mode.

### How to update firmware with the Slot.it APP

This section assumes that you are familiar with the Slot.it app and that your controller has been registered already.

Start DFU, according to any of the procedures described so far.

Contact your controller, then select DFU. The app will take you to a list of firmware versions, Pick the one you want, then start DFU upgrade.



Users of Apple's iOS can only perform DFU using the Nordic's app.

**If your controller displays the 'Pt' letters on the display, please jump to the chapter "The mystery of the 'Pt' message - solved!" near the end of this manual.**

## How to update firmware with the NORDIC APP

The upgrade can be initiated with the Bootloader or by putting the chip directly in DFU mode via one of the methods mentioned before.

1. Download the *nRF toolbox app* for your *Apple iOS* or *Google Android* device.



2. Download the firmware version that you want to put on your SCP-3 from our website (<http://www.slot.it> – oXigen Download Firmware area) on the device. Note where it is being saved. Remember that Your firmware has a name and the name follows this convention: SCP3-*device*-*sys*-*rel*-*date*.zip file, where:

*device*: Handle (HN), Power Amplifier (PA), or Horbny ARC PRO controller (ARC)  
*sys*: system oXigen (O2), Scalextric SSD (SSD) or Slot.it digital cartridge (DIG).

(Note: the Power Amplifier's firmware is the same for O2 and ARC PRO)

*rel*: firmware release number

*date*: firmware release date (yymmdd)

Examples:

O201c-HN-O2-0311a-200707.zip: oXigen firmware for SCP-3, version 0311a, released on Jul 07, 2020

O201c-PA-0311b-200805.zip: Power Amp firmware released on May 8, 2020

3. Start the *nRF Toolbox app* on the device and select DFU button





4. Tap on *SELECT DEVICE* and choose *DfuO2HC* which should appear in the list of available devices, under your list of paired/bonded devices. If it is not present, repeat the steps above to set the SCP-3 to *DFU* mode.

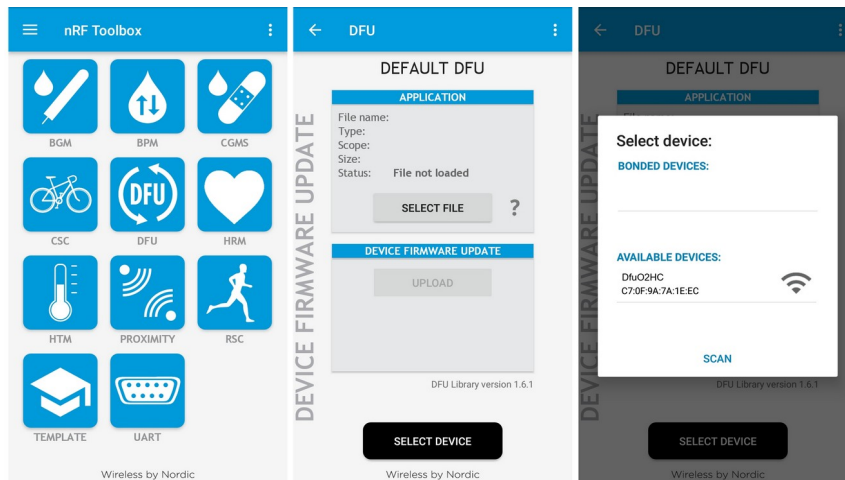

5. Tap on *SELECT FILE*

6. Choose *Distribution packet (ZIP)* and press *OK*.

Now locate the file you just downloaded at step 2, select it, then select *Scope: All*

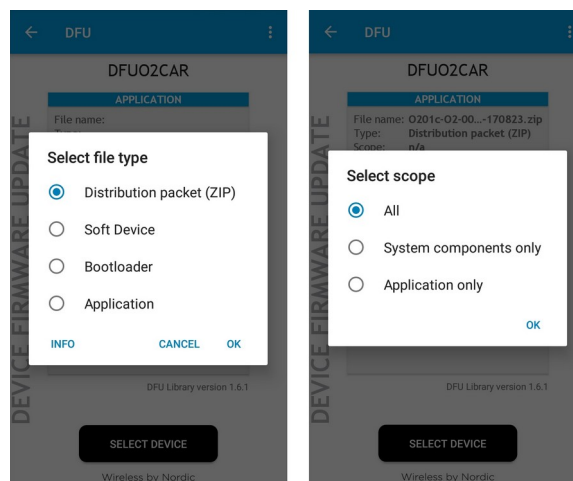

7. If given a choice, choose the whole file, not a part of it. Once the file has been selected, the app returns to the *DFU* screen.

8. Tap on *UPLOAD*: Firmware upgrade should start and be finished in a few seconds.



9. The chip resets automatically after being upgraded, but you may need to lift and put the car back on the track before using it.
10. The area of memory which is reserved to pairing info and other setup values is not overwritten during the update of the firmware, therefore your pairing will not be lost.

**BATTERY SELECTION (for 2.4GHz oXigen / ARC SSD wireless systems  
Use ONE SINGLE CELL ONLY (3.7V) Lithium battery. Do not exceed voltage!**

The SCP-3 can be powered by an optional single cell (3.7V) Li-Po battery which may be stored inside the handle, in place of the cartridge. If powered by the battery, the SCP-3 becomes a wireless, untethered device directly compatible with Slot.it oXigen and Scalextric SSD digital systems.

LiPo batteries can be damaged if allowed to discharge below a safety threshold. Our electronics incorporates a circuit which protects the battery against over discharging.

The battery inside the SCP-3 can be charged like the battery of a normal mobile phone through the USB charger plug. The controller cannot be operated via USB battery charger power alone.



Battery specification

Capacity	750/1000 mAh
Voltage	3.7V (1s) - <b>1 cell Li-Po only - do not exceed</b>
Undervoltage protection	Preferably yes
weight	approx. 20g
Max W*L*H	<b>45x28x10 mm MAX</b>
Balance plug	NA
Plug	JST 2pin

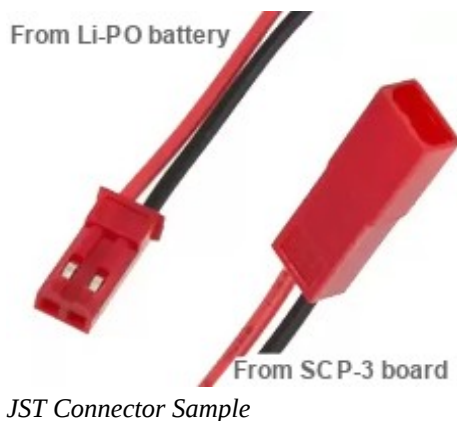

**The 2.4 GHz radio section of the SCP-3 can also be used if the controller is powered via the SCP-3 power supply cartridge (SCP301c).**

## Description

The SCP-3 is a speed controller for slot cars. It reads the trigger position using a contactless, friction free sensor, with linear magnetic trigger position readout. It is directly compatible, via the built-in 2.4 GHz wireless interface, with digital oXigen and Scalextric ARC AIR/PRO systems. Like its predecessor SCP-2, it features an interchangeable cartridge system, to connect to analog systems.

The SCP-3 is compatible with all SCP-2 cartridges, analog or digital, with one exception: the old oXigen cartridge, which is not needed as the 2.4GHz oXigen system is an integral part of the SCP-3, is not supported anymore. Analog and digital cartridges require different firmware to be loaded into the SCP-3 - this is easily done via the Slot.it or Nordic app.

Warranty: two years from the date of activation. Before usage, the SCP-3 must be connected to an Android or iOS phone and 'activated', that is, the date of its first use is written into the controller's memory and in our database. We recommend to keep the receipt anyway, in case the SCP-3 cannot be contacted via radio anymore.

This device complies with RoHS directive. Do not immerse this controller in water.

Thanks to all our beta testers whose work was essential to help us bring this product to market.

The name SCP comes from the nickname SeCaPelo (Secapelo=Hairdryer) that was given to early Slot.it controllers.

This controller is Made in Italy and is the result of the hard work of Maurizio Ferrari, Maurizio Gibertoni, Cristian Anceschi of

Galileo Engineering srl, Via Cavallotti 16 – 42100 Reggio Emilia, Italy [info@slot.it](mailto:info@slot.it)

So, now you know who to blame.

Please also check out our [Slot.it](http://Slot.it), [Policar](http://Policar) and [Galileo Engineering](http://Galileo Engineering) sites!

Slot.it and the Slot.it logo are registered trademarks belonging to Galileo Engineering srl.

Slot.it is in no way affiliated with Carrera, Hornby Hobbies, Ninco, Tecnitoy; Carrera Pro-X, Carrera Digital 132, Hornby SSD, Ninco N-Digital, Tecnitoy The Digital System SDS, are registered trademarks belonging to their respective owners.

  **Electronic versions of the manual in Italian/Castellano/German can be downloaded from the Slot.it site [www.slot.it](http://www.slot.it).**

# Slot.it SCP-3 1.0

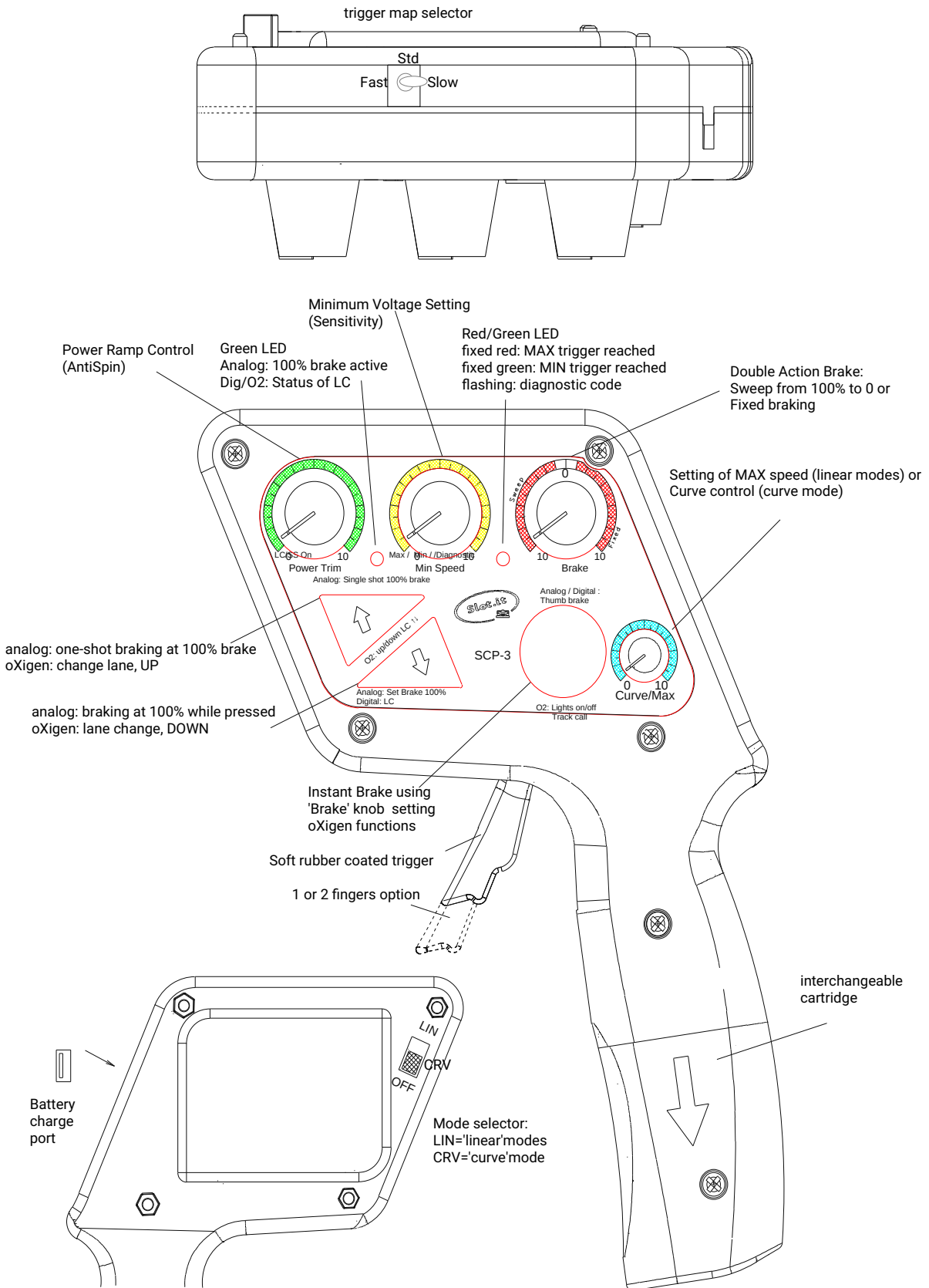



## BEFORE YOU START

## Choose a trigger



 (UK) Install the trigger that matches your driving style: short (for one finger) or 'long' (for two fingers). Use the provided screw.

## QUICKSTART for ANALOG SYSTEMS (SCP-3 with analog cartridge)

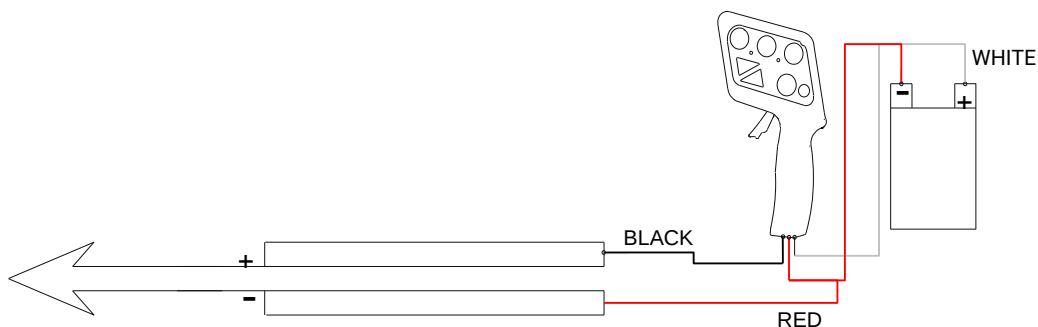

 (UK) The colour scheme of the SCP-3 cables follows the standard US (Parma) colour coding. In our opinion, it does not make sense to use anything other than red for battery power and anything other than black for ground, however since the long time standard established convention is different, we decided, reluctantly, to follow it.

So: WHITE is +, RED is – (ground), BLACK is motor (track). If you have a DS connection box, colour will match the existing colours on the female plugs of the box.

Anyway: plug the WHITE/YELLOW cable into the POSITIVE (+) terminal of your track; plug the RED cable into the NEGATIVE (-) terminal of your track; plug the BLACK terminal to the motor connector of your track, then go to the **Quickstart common section** chapter.

Technical Specifications	
Power supply	7 to 24V
Maximum current: home racing cartridge high end cartridge	5A 40A
Operating temperature	0 to 40°
Weight	270 g

As a radio device, it operates on the 2.4GHz band either as a BLE (Bluetooth Low Energy) device, to interface with, for example, a mobile phone, or on the proprietary oXigen or Scalextric SSD ARC AIR/PRO networks and protocols.

## **QUICKSTART for oXigen and Scalextric ARC AIR/PRO SYSTEMS**

 <sup>UK</sup> . The SCP-3 is directly compatible with oXigen Slot.it wireless digital system. You should not use the old oXigen cartridge (for SCP-1 and SCP-2) with it. An extra Power Amplifier Module is available if you need to cover extra distance.

It can also be used as a Scalextric ARC AIR/PRO controller.

Refer to the firmware update section of this manual, and to the oXigen manual for instructions about how to use the SCP-3 in an oXigen or ARC AIR/PRO system.

## **NOTE for DIGITAL SYSTEMS (SCP-3 with digital cartridge)**

 <sup>UK</sup> The Slot.it SCP-c controller is also compatible with the Slot.it digital cartridge for SCP controller. An ad-hoc firmware must be installed. It can be installed following the procedure described in the firmware update section of this manual.

## QUICKSTART common section

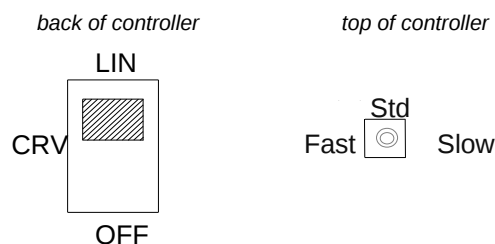

 (UK) Move the slider on the back of the controller to the LIN position, and the top switch on STD.

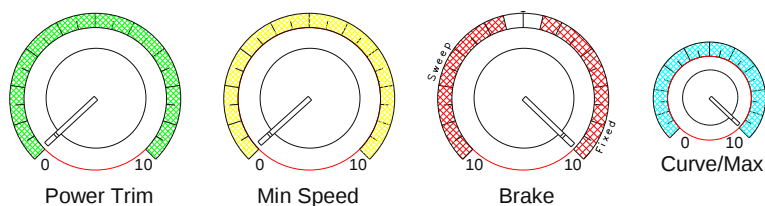

 (UK) Turn the 'Power Trim' and 'Min Speed' knobs completely counterclockwise. Turn the 'Brake' and 'Curve/Max' knobs completely clockwise.

Press the trigger and the car should start. Adjust the 'Min Speed' knob to get a good starting speed; this will depend on the track, car, driving style and voltage. Then, adjust the Curve/Max knob to suit the whole curve to the desired response. Have fun. Then *please*, read the rest of this manual. Please. It is important, otherwise we wouldn't have written it. In particular, advanced users should read the chapter named 'Reprogramming the SCP-2')

 (UK) Complete electronic versions of the manual may be downloaded from the Slot.it site [www.slot.it](http://www.slot.it)

**NOW READ THE COMPLETE MANUAL!  
ORA LEGGERE IL MANUALE COMPLETO!  
LEA Ud. AHORA EL MANUAL COMPLETO!  
DAS KOMPLETTE HANDBUCH JETZT LESEN!  
MAINTENANT, LISEZ LE MANUEL!**

## Understanding how the SCP-3 works

 (UK) The Slot.it SCP-3 is a sophisticated, microcontroller based, speed controller for slot cars. It has a PWM output for both power and brake, plus a lot of other features.

Without entering too much into detail, PWM (Pulse Width Modulation) is one of the possible ways to control the output voltage of an electronic system. A PWM system basically 'chops' the output voltage in a series of on-off periods, whose on-off ratio corresponds to the desired voltage according to the formula  $V = \text{on-off ratio} * \text{track voltage}$ . In other words, if you have a track voltage of 12V, and an on-off ratio of 1/4, you are feeding your car  $1/4 * 12 = 3V$ , and so on.

The ratio is chosen by the microcontroller, according to the trigger position and to the desired 'response curve'.

### The switch: 'Fast', 'Standard', 'Slow'

With the advent of the SCP2 we have redesigned the underlying mapping system, to make it easier to use, and more effective: both 'linear' and 'curve' modes can now be used in three fashions: 'fast', 'standard', 'slow', these terms referring not to the overall speed of the car, but to the speed of the car at a given trigger position. In other words, the trigger readouts are 'remapped' on an *aggressive* (fast), *standard* (std) or *soft* (slow) trigger readout.

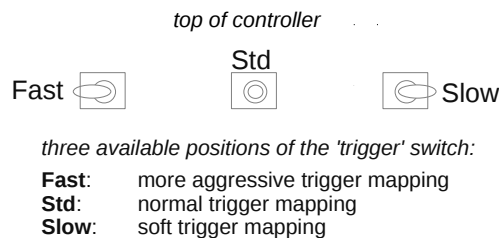

### Available modes

- 1. LINEAR with step (mode 1):** the relationship between the trigger and the voltage output is a straight line. The controller, when the trigger is fully pressed, will always provide 100% power. Due to its innovative and in our opinion clever, strategy, this mode has a lot of flexibility and can help in the most difficult situations.
- 2. CURVE mode (mode 3):** the relationship between the trigger and the voltage output is not a straight line, but can be made convex or concave more or less at will.  
There is also a further useful mode:
- 3. GHOST mode (mode 4):** a self-run mode with adjustable speed, useful for running a ghost car on the circuit (or more, if more digital cars are programmed with the same ID), or running in a motor.

### So where did the 'kid's mode go?

We removed it - it will be available from the accompanying APP, with which users may limit the maximum speed to a desired level.

## Mode 1 – LINEAR with step

### UK Entering Mode 1

Mode 1 is selected by putting the switch on the back of the controller to the 'LIN' (top) position, and

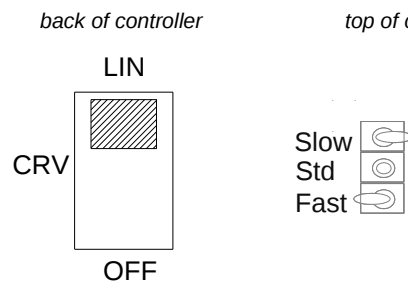

the switch on the top side, to any position:

### UK Using Mode 1

In the development process of the SCP controllers software, at a certain point we started to investigate why a given car, very easy to drive below a given voltage, was very 'rough' and unpredictable with increasing voltage levels. It was not a matter of excessive speed, the problem lied in the broken link between the finger and the car: somehow, a well-behaved system became increasingly wild and uncontrollable. Every slot car racer knows that more voltage doesn't always make a faster lap time, but we needed a physical, logical explanation to this well-known fact.

Come think about it, a basic truth applies: more or less, *the speed of a given car in a given turn is largely independent of the motor power*, that is, provided your motor is powerful enough, and most motors are powerful enough to de-slot a car in a turn, the speed in a turn depends on many factors but not the power of the motor, or the track voltage. So, what happens when you increase the voltage, and why does it make things so much more difficult?

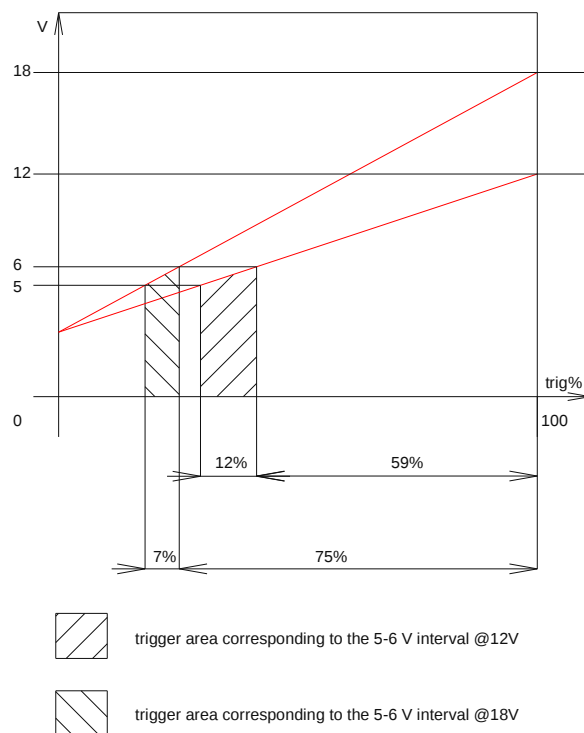

UK Let's suppose in a given turn the car can be driven optimally in a voltage range between, say, 5 and 6 Volt. In the given example (which is an example only), at 12V this range falls across a 12% band, which, in turn, is located approximately 30% from 0. But look at what happens at 18V: the same 5-6 Volt band is now spread across a 7% band, which is also much closer to the 0 position



than before!

So, ideally one would want, in this case, to have a controller, which responded as if the power was 12V in the turns, and 18V in straight lines.

From this observation, the 'linear with step' mode was created to keep the power band under control, without sacrificing top speed.

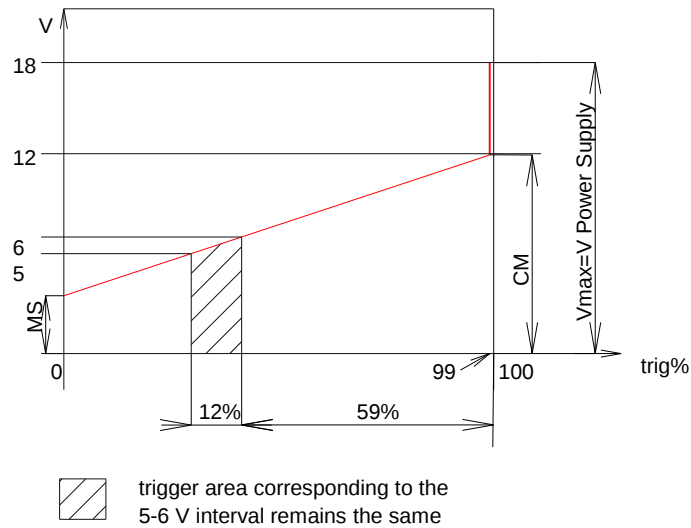

 (UK) It all works like this: the Min Speed (MS) knob and the Curve/Max (CM) knob set respectively the desired attack voltage, that is, the minimum voltage applied to the motor, and the voltage which is applied when the trigger is at 99% of its run, that is, just before the physical maximum of the trigger's run. When the trigger is pulled 100%, full power (be it 12, 18 or any voltage) is applied. By doing so, it is possible to maintain a fixed, ideal power band for turning, irrespective of track conditions, and to take advantage of the full power on the straights. The transition between the CM value, and the full (100%) Vmax, is actuated according to the setting of the Power Trim knob: the more Power Trim is requested, the slower the transition between CM and VMax

It is an easy to tune, very effective strategy.

## Mode 3 – CURVE

### UK Entering Mode 3

Select mode 3 by putting the switch on the back of the controller to the 'CRV' (bottom) position.

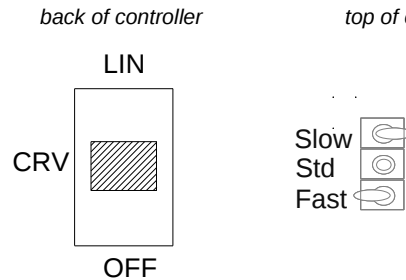

### UK Using Mode 3

The 'Curve' mode is very flexible. By appropriate adjustment of the Curve/Max CM knob, the response curve can be custom tailored.

To understand how it works, consider that the curve of the trigger position/Voltage relationship is built by three points:

1. Min, which is the attack speed set by the MS knob, and varies according to the relative setting.
2. The middle point, which is on the intersection of two lines: one, a horizontal line on the vertical 'voltage' axis, placed at 50% of the axis length, and the other, a vertical line on the horizontal trigger axis, whose position depends on the Curve/Max knob position. The intersection of these two lines sets the middle point.
3. The Max Voltage, which in this case is always 100%, that is, in the 'curve' mode it is not possible to decrease the maximum power.

In the following example, given a certain MS knob position, by turning the CM knob the curve varies as shown below.

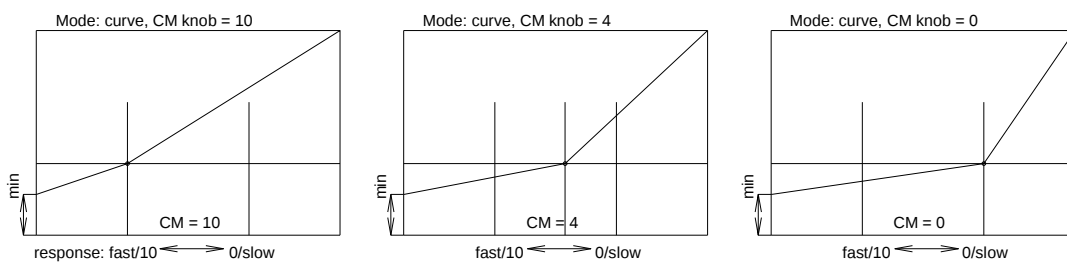

Example of curves with given MS, CM change

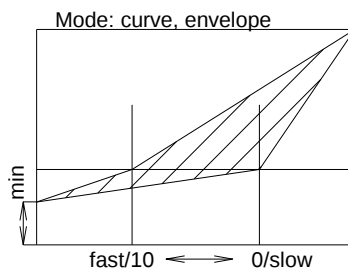

Envelope of curves with given MS, CM change

Obviously, the curve can vary continuously between the one represented with CM=10 and the one with CM=0. The middle curve, with CM=4 is an example of an intermediate situation. The envelope of possible curves, with the above said fixed MS, is explained by the picture right above.

What happens now to our curves, if we change the position of the minimum speed (MS) knob?

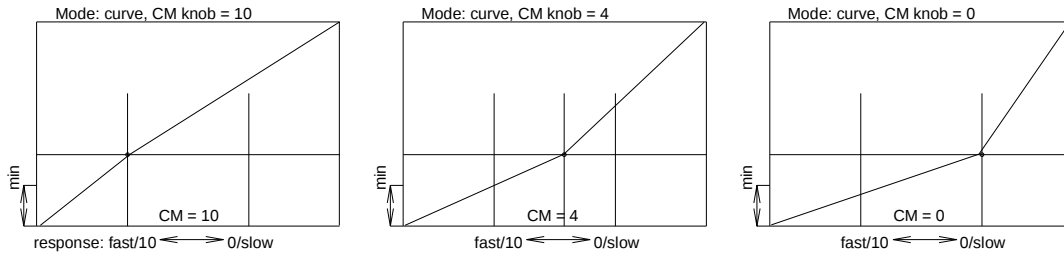

Example of curves with MS=0, CM change

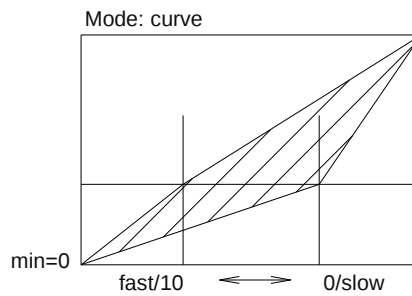

Envelope of curves with MS=0, CM change

At this point, it is easy to visualize the complete envelope of a sample situation, i.e. the complete set of curves that can be obtained with fixed dip switch position, and adjusting CM and MS knobs:

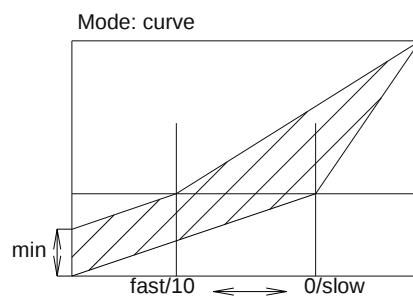

Envelope of curves when MS and CM vary

All this said, in Mode 3, as in the other modes, the trigger mapping can be set to an aggressive, standard or soft response using the additional switch, located on the top of the controller.

## Mode 4 – GHOST - explained

### (UK) **Entering Mode 4**

Activate the GHOST (auto run) mode by executing the following actions in sequence:

1. turn the Curve/Max knob completely counterclockwise to 0
2. put the CRV/LIN switch on LIN
3. press HAND BRAKE
4. keep HAND BRAKE pressed and press both arrow buttons (LC and Latched LC)
5. pull the trigger to full power
6. completely release the trigger
7. release all the buttons – the LEDs start flashing indicating GHOST mode
8. set speed with CM knob

### (UK) **Using Mode 4**

Speed can be adjusted with the Curve/Max knob. The Hand Brake button, as well as the Lane Change buttons (digital mode), work.

Exit mode by quickly pulling the trigger to full power and releasing it.

Note that the mode can be entered also skipping step 1. above. The risk in this case is that the speed is adjusted by said knob, so if you leave it to a high setting, as soon as you release the Hand Brake button in step 7, the car will start at warp speed and crash. So, please play safe and turn the CM knob to low before entering mode 4

## SCP-3's controls

 (UK) The SCP-3 has four main knobs, three push buttons, a sliding switch and a lever switch.

 (UK) **Power Trim (PT)**: also known as 'antispin', this knob controls how the power trim strategy delivers the power to the car.

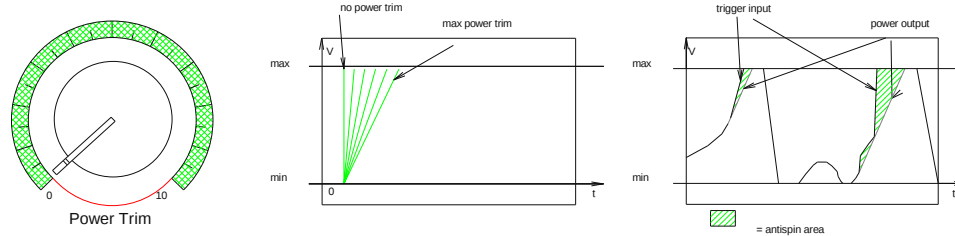

The PT knob sets the maximum accepted 'slope' for a power increase: if the power increase ratio is above this slope, the 'power trim' slope is applied instead. In other words: if the trigger is pulled sharply, the power increase ratio is very high: in this case, the power trim strategy releases the power to the car through a more gentle slope. In reality, a 'real' antispin should monitor the wheel speed and detect wheelspin before cutting back the power. This is not what this controller does, which is, instead, a 'smoothing out' of the trigger action.

Actually, this idea is rooted in what was legal in the F1 rules in the 90s: real closed loop antispin being banned, this was as close as one could legally get.

 (UK) **PT for digital systems**: there is no difference between the analog and digital controller as far as the PT is concerned.

 (UK) **Curve/Max (CM)**: the core of SCP-2's inner working. Depending on the chosen working mode, "linear", "linear with speed limit", "curve", it has two completely different functions.

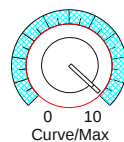

"linear", and "linear with speed limit" modes: if you have *not* read the explanation on these two modes, then now it's probably time to read the relevant chapter. If you have, then this knob sets the maximum speed in both cases.

"curve": if you have *not* read the explanation on this mode, again you should do so now, or proceed at your own risk.... If you have, this knob, in this case, moves the working point on the 'X' axis and sets the third point through which the curve is set, the other two points being the minimum selected by the MS knob, and the 100% fixed maximum.

 (UK) **CM for digital systems**: there is no difference between the analog and digital controller as far as the CM is concerned.



 **Min Speed (MS)**: this knob sets the starting speed of the car, i.e. the minimum voltage which is applied to the track, when the trigger is pulled just enough to leave the 'braking' area. Also known as sensitivity, in terms of a traditional resistor based controller, it is similar to changing the resistor's value, to get a faster or slower start point.

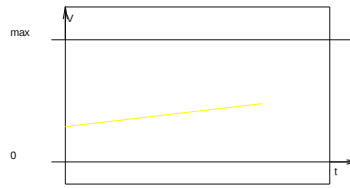
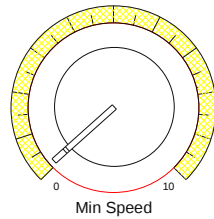

 **MS for digital systems**: there is no difference between the analog and digital controller as far as the MS is concerned.

 **Braking (BK)**: braking occurs when the trigger is completely released. The braking knob selects between two different braking strategies: 'sweep' and 'fixed'. The braking dial is split in two halves: one, under the label 'sweep', puts the braking system in 'sweep' mode, the other half, under the label 'fixed', does the same but for the 'fixed', standard, mode. As this tautology is not probably the best possible explanation, please look at the picture and read on.

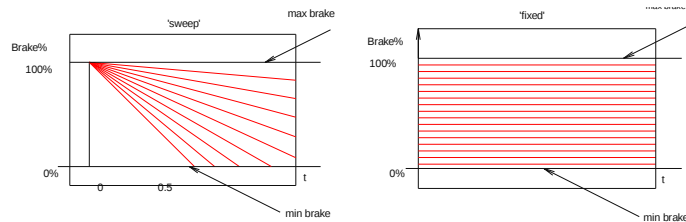
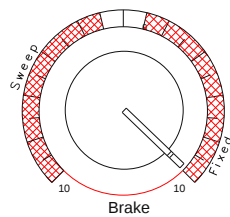

If you have ever been fortunate enough to look at some telemetry data from a real racing car, you might have noticed that the deceleration peaks at the beginning of the braking (in a modern F1 car, deceleration can reach 5g), then decreases as the driver eases the pressure on the pedal, as he tries to match the car's speed to the desired entry speed for the next turn. This is what the 'sweep' braking strategy tries to accomplish: a strong initial braking followed by a gradual easing of the braking itself. In other words: the sweep always begins with 100% braking, then, gradually reduces it to 0 (zero), as time passes. When turned counterclockwise in the 'sweep' area, the knob position controls the sweep time, i.e. how long does it take to bring the braking from 100% to 0. Note that, when fully turned counterclockwise, the braking is fixed at 100%, or, if you like to put it this way, the time it takes to bring the braking to 0 is infinite. Apart from this position, the longest available sweep is 1.7s, and the shortest is 0.5s.

The 'fixed' mode, clockwise, is the 'standard' mode of most, if not all, other controllers with adjustable braking: depending on the dial position, you get a stronger or weaker braking according to the knob setting.

 **BK for digital systems**:

**oXigen, ARC PRO**: works as analog.

### **Brake overrides (analog mode):**

 NOTE: EARLY FIRMWARE MAY NOT HAVE THIS FEATURE YET. There are two ways to change the brake setting on the fly, and temporarily, without altering the base setting selected by the BK knob:

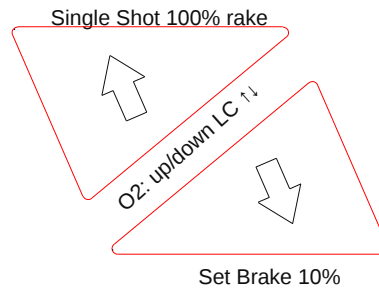

1. the 'UP' arrow button performs a 'single shot' brake override: the next braking action will always occur at 100% braking, regardless of the current BK settings. This can be useful in several situations: for example, in a circuit where 100% braking would not be the best choice, except for a single narrow turn. While active, that is, when the button has been pressed but braking did not take place yet, the green light stays ON. A further pressing of the 'UP' arrow when the strategy is active will switch it off.
2. the 'DOWN' arrow button, while pressed, overrides any braking knob settings, forcing braking at 100%, as long as it is pressed.

### **Lane change (oXigen):**

 oXigen, when used with appropriate hardware, has a 'Selective Lance Change' feature allowing users to switch or not depending on the direction of the lane changer (left or right): therefore, depending on the programming of the lane change mechanism, pressing either arrow has different results. In other words, arrows correspond to left or right changing. Press both buttons together to activate the lance change mechanism regardless of directions.

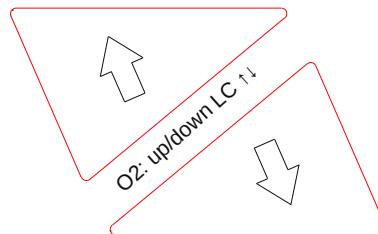

### **Lane change (Scalextric ARC AIR/PRO):**

 Pressing either arrow activates the lance changing mechanism, as Scalextric's ARC doesn't support the selective lance changing protocol.

**Hand brake (analog and digital mode):**

 (UK) The round push button marked 'Hand Brake' is an instant brake, thumb activated. While pressed, power is cut and braking performed according to the BK knob setting.

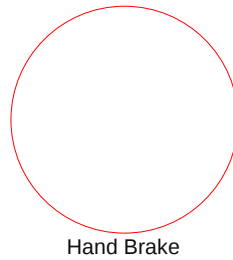

**LIN/CRV/OFF selector and Switch (top of controller):**

 (UK) The LIN/CRV/OFF selector and the Switches are located respectively on the back and on the top of the controller. Together, they are used to select the working modes of the SCP-3, and to turn it OFF, of course.

*back of controller*

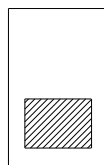

CRV

*top of controller*

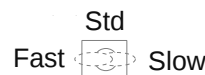

**Live Timing (Telemetry) interface:**

 (UK) **THE SCP-3 IS NOT COMPATIBLE WITH THE LIVE TIMING SYSTEM**

## How does the SCP-3 protect itself

 (UK) As the SCP-3 can operate in a very harsh environment, it has several ways of protecting itself against short circuits and polarity inversions. **The following applies to analog systems with 'home racing' cartridge only.** The high end cartridge is protected differently, by fuse and by higher MOSFET current rating (80 A in ideal conditions).

### (UK) **Protection against short circuit between rails:**

This is the most common situation in normal use. A screwdriver on the track, a screw across the slot, a copper filament crossing the braids are normal events that any controller should handle gracefully. The power MOSFETS used in the SCP-2 are well dimensioned, but this alone is not enough to guarantee a happy and healthy life to your controller. So, the Slot.it SCP-2 continuously monitors the current drain from the track and cuts power if the current is higher than 6A. The situation is checked every few tenths of a millisecond, and if the short circuit goes away, power is restored. The 'diagnostic' LED flashes with one flash every two seconds while this condition is detected.

This obviously means that with the 'standard' analog cartridge, motors with a very large current drain cannot be used. This excludes the motors commonly used for 'metal slot racing' but includes all motors commonly used in plastic cars. An 'unlimited' cartridge, is planned, for higher current requirements.

In the table below, this protection is referred as SC.

### (UK) **Protection against short circuit to Ground:**

This is quite unlikely during normal use, but can be caused by a mismatch between Motor and Ground cables.

The 'diagnostic' LED flashes with two flashes every two seconds, while this condition is detected.

In the table below, this protection is referred as SC.

### (UK) **Protections against polarity errors:**

The SCP-2 has three cables: **Motor** (Black), **Ground** (Red), **Power** (White).

Two devices protect the SCP-2 against polarity inversion, which happens if the cables are mismatched. This should not happen often, but it *can* happen, so the SCP-2 is shielded by

1. Fast Fuse, 3.15A, replaceable. In the table below, this protection is referred as FF
2. Resettable Fuse (Automatic). In the table below, this protection is referred as RF

Track connectors	SCP-2 connectors					
Motor	Motor	Motor	Ground	Ground	Power	Power
Ground	Ground	Power	Power	Motor	Ground	Motor
Power	Power	Ground	Motor	Power	Motor	Ground
Effect →	OK	FF	RF	FF or SC	RF or SC	FF or SC

### (UK) **What to do:**

If the diagnostic LED flashes once every two seconds, unplug the controller, search and remove the offending item that is shorting the rails. Check that your motor is not draining too much current.

If the diagnostic LED flashes twice every two seconds, unplug the controller, and check your connections.

If you believe there might have been a condition like the ones above, check the Fast Fuse and in case, replace it. The automatic Resettable Fuse resets automatically in approximately 2”.

## **an IMPORTANT word about the trigger readout and reprogramming the controller curves**

 (UK) The SCP-3 reads the trigger position from two magnets housed in the trigger itself. The magnetic field is read by a Hall sensor, whose linear output is fed to the microcontroller (the CPU). What makes it interesting for the user though, is that, being there no end of run switches or mechanical contacts, there is no friction between the trigger and the cursor as in a traditional controller, which means no wearout, no dust, no change in characteristics.

The SCP-3 comprises a sophisticated software which can detect the end-of-run positions and self calibrate during normal operation. It comes precalibrated from factory so that it works as expected as soon as it is powered up.

Version 1.1. of the SCP-1 controller (November 2010) added an important new feature: it is now possible to reprogram the factory-set base relationship, which links the physical position of the magnet (trigger position, in degrees) to the logical point on the mapping. In other words: underneath all the curves that you have read so far, lays a base mapping through which the controller knows that a certain readout of the magnetic field corresponds to a certain position of the trigger. It is this 'base' relationship which makes it possible, for the software, to create all the curves of the SC 1.1, then SCP-2, and now SCP-3. A small change of the 'base' map, which normally is hidden from the user, can radically change the behaviour of the controller. The base mapping is set during production, but a rewrite of the mapping must be performed every time the trigger magnet is replaced.

For the user, then, it is now possible to alter the *base* setting, as if you were using completely different magnets. Please refer to the 'Reprogramming the SCP' document, or to the single-language manual for an explanation of the procedure, all of which are downloadable from the Slot.it web site



## The mystery of 'PT' warning...solved!

 (UK) If the firmware of the SCP-3 is updated from a version less than or equal to 3.10 to a version greater than or equal to 3.12, the controller is reverted to the 'Production test' (Pt) stage. This is an unavoidable consequence of necessary internal memory arrangement that took place at that time, and is a known fact.

This means, the two round LEDs are lit in orange and green, and the LED display shows 'Pt'.

The controller is back to the point it was when it leaves the production line and it is going through the production test routine.



The SCP-3 can be returned to normal operating conditions by following the procedure below.

1. Program the trigger curve as described in the manual, starting from page 3

[http://slot.it/wp-content/uploads/2020/04/ReprogrammingSCP-2.en\\_.pdf](http://slot.it/wp-content/uploads/2020/04/ReprogrammingSCP-2.en_.pdf)

In detail:

- turn the blue knob, bottom right, fully counterclockwise
- leave the trigger unpressed. Press and release the round button. Left LED stays green, right LED turns on in red.
- press the trigger until the small plastic arrow indicating the angular position reaches mark '15' on the white scale

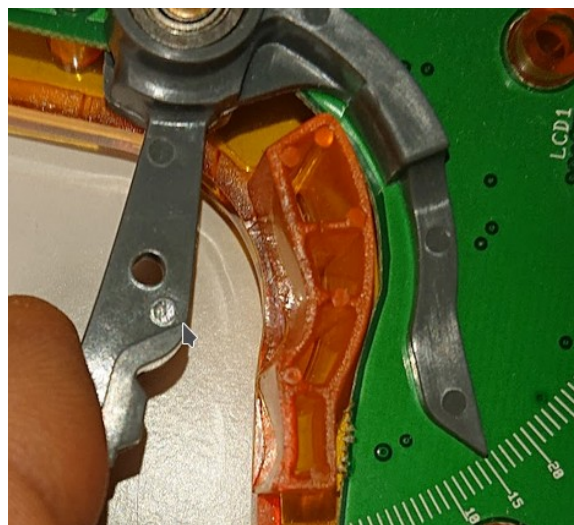

- keeping the trigger in this position, press and release the round button. Both LEDs are lighted up in green

- press the trigger to the angular position marked '25'

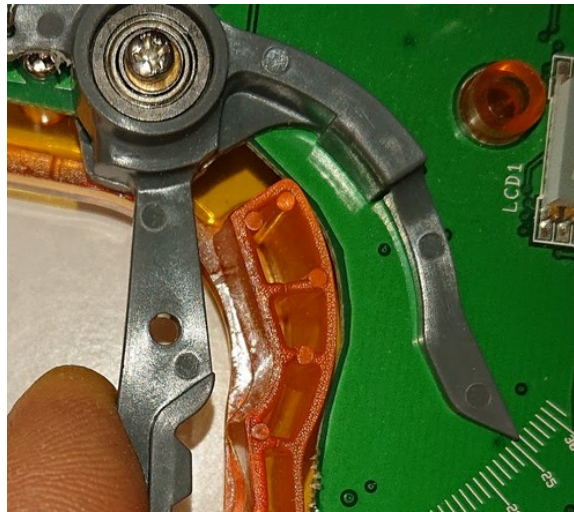

- keeping the trigger in this position, press and release the round button. The green left LED turns OFF, the right LED stays green
- press the trigger fully
- keeping it pressed, press and release the round button
- the green LEDs will start blinking indicating that the programming is finished
- once the two LEDs are blinking, turn off the SCP3. The curve programming procedure has ended.

2. Exit 'Pt' mode: turn on the SCP3 and verify that only the right LED is lit, in green. The left LED is off. LED display shows 'Pt': press all the three buttons together (both up/down arrows and the round buttons) until the display shows 'do'. Then release the buttons.

3. Contact the controller with the APP, which should take care of the rest.

**if everything else fails...**

press the large, friendly orange button:



...and contact us at this address:



Galileo Engineering srl, Via Cavallotti 16 – 42100 Reggio Emilia, Italy

[www.slot.it](http://www.slot.it) - [info@slot.it](mailto:info@slot.it)