



<https://www.free-ride-addicted.fr>

Adjustable Release Footstraps Bindings:

Preamble

Thank you for purchasing these Adjustable Release Footstraps Bindings.

When falling forwards with significant traction on the strap (adjustable threshold), the metal hook of the binding will tilt and release the plate attached to the strap. The apparent simplicity of the mechanism is the result of long hours of reflection following a broken foot ...

Conversely, the mechanism will not trigger for pull-ups during toe lifting. You can therefore pull on the straps without inadvertent triggering

Please feel free to tell me about any ideas for improvement, any flaws or difficulties you could encounter.

Disclaimer

If you have purchased this equipment, it is because you are aware of the risks involved in windsurfing or windfoiling and the lack of safety of current footstraps. The Free-Ride-Addicted footstrap bindings (patent pending) allow the foot to be freed from a forward fall but cannot negate all the risks presented by these sports.

Skiing isn't practiced with shoes bolted to the boards, but unfortunately the traumas of the lower limbs remain.

Places for the different models:

There are 4 different types (x left/right), each for a specific location on the deck.

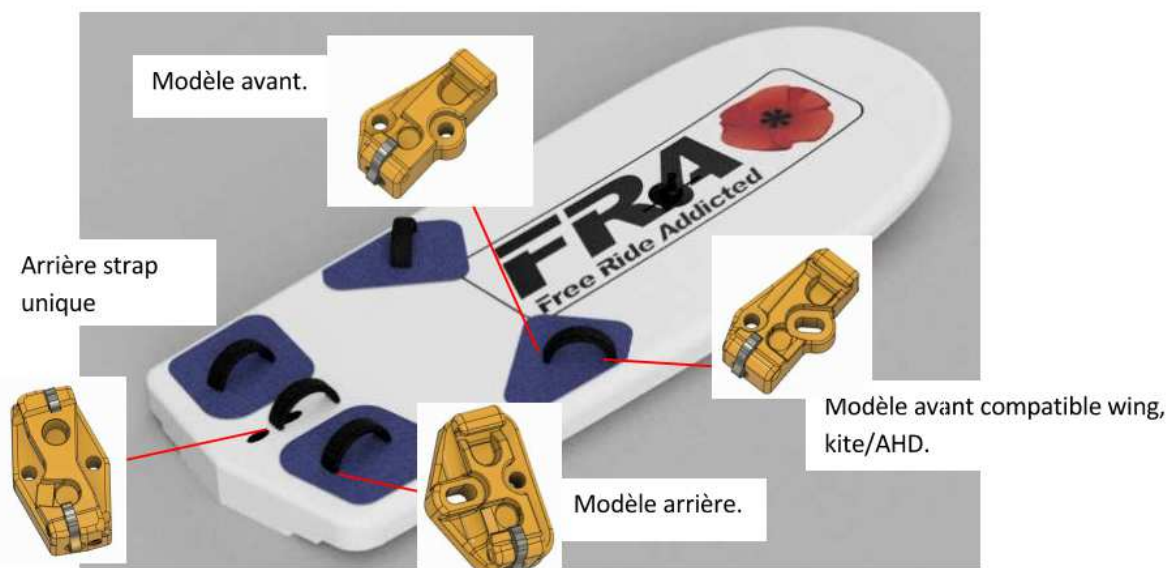

The latest version is dedicated to single rear straps. It includes 2 reversed mechanisms in the same plastic piece. It will release on forward falls on both tacks but will not open on backward falls with hyper extension of the ankle.

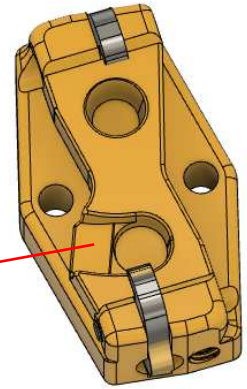

Vers l'arrière de la planche.

Overall view:

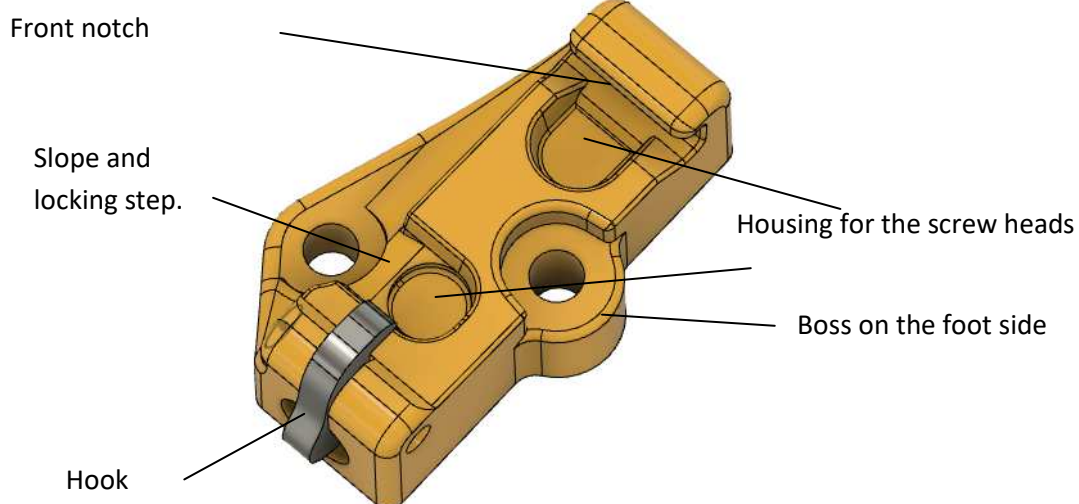
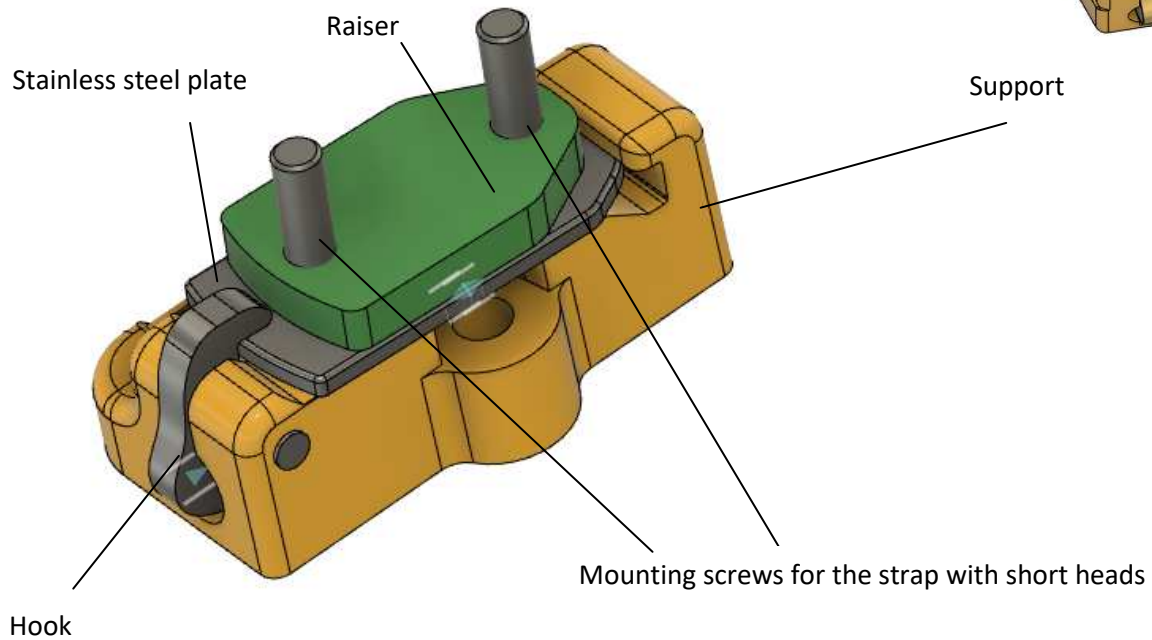

Installation

Video here (french at the moment) : <https://vimeo.com/430364850>

Or here for the wingfoil compatible model (en subtitles)

<https://www.youtube.com/watch?v=PZ3vxYrJZoM>

These links are also on the e-store where you can also find this pdf..

Mounting the supports: The 2 parts are symmetrical. The hook must be located towards the heel. The right part as an R printed under, L for the Left one. The part shown above is suitable for the right foot.

Each support must be mounted with 2 screws so that it does not rotate. The front support may have 3 holes. There should always be a screw in the hole closest to the hook. A second screw is to be put either on the same side of the part or in the hole on the foot side.

For the rear single strap model, the engagement slope must be toward the rear of the board.

Mounting the plates on the straps:

2 identical plates for the front or rear models, (CF video from 3mm) position the most rounded side towards the toes (Cf drawing opposite). It may be necessary to improve the holes in the strap with a heated soldering iron or screwdriver. Depending on the thickness of the straps, 2 sizes of screws are included. One plate is equipped with long ones the other with shorter ones. Choose which suits you best and replace 2 of the screws.

For the wingfoil compatible model plates are asymmetrical, the wedged side needs to be toward the foot.



Front wingfoil compatible model (right foot) with its plate.

For the rear single strap model, the groove in the steel plate goes on starboard.

Engagement: (CF video from 4mm40 40 '). Slide the front end of the plate into the notch in the support. Turn the rear part of the plate a quarter of a turn outward to bypass the hook. Slide the corner of the plate under the hook, push on the bottom of the hook if necessary. Complete the rotation. The click sound means the second screw head is positioned in the support housing.

Do not try to remove the support from the board without triggering the system first. Loosen the adjustment and if necessary use a flat screwdriver on the plastic slope to open the hook.

Setting

The internal screw makes it possible, by compressing the retaining spring to a greater or lesser extent, to adjust the release force. It is therefore of the user's responsibility to ensure that the setting is suitable for his practice.

The optimal setting should allow navigation without unwanted triggering while offering the possibility of triggering the system with a sharp tilt of the foot.

A first adjustment is to be made on land by tightening the adjustment screw 3 turns from the flush position. Then test the trigger on water or on land with this setting. Harden (by screwing) or soften by half-turns. Take a key with you during the first rides to refine it according to your practice. Retesting your adjustment from time to time will be a good practice which is quite reassuring.

Maintenance :

As with any mechanical component, although made of plastic and stainless steel, seawater (salt, sand) can create problems over time. It is therefore recommended to rinse the mechanism with fresh water from time to time.

To do this, completely remove the adjustment screw, apply a garden hose to the hole thus freed and rinse.

On the rear single strap model, the housings of the springs communicate so that you can rinse in both directions without removing the adjustment screws.

Also check the position of the axis which may move slightly over time.

Warranty :

2 years.

Good and numerous safe rides