



PLANBAY

Removable separation kit concept for unused seat

*Florian Barjot
May 2020*



by





Introduction

- Removable kit for the time of an epidemic outbreak
- Designed for economy class seat rows
- The goals:
 - Provide a kit solution for an empty seat to increase physical distancing
 - Easy to produce & low-cost
 - Quick & easy to install and remove
 - Maintain the direct view control by the cabin crew
 - No modification to the seats and compliance with CS25.785 & CS25.853

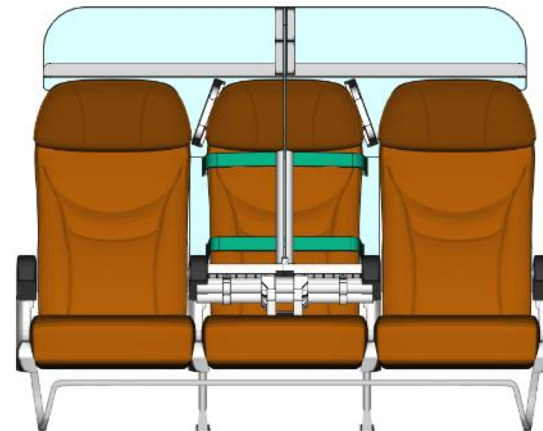
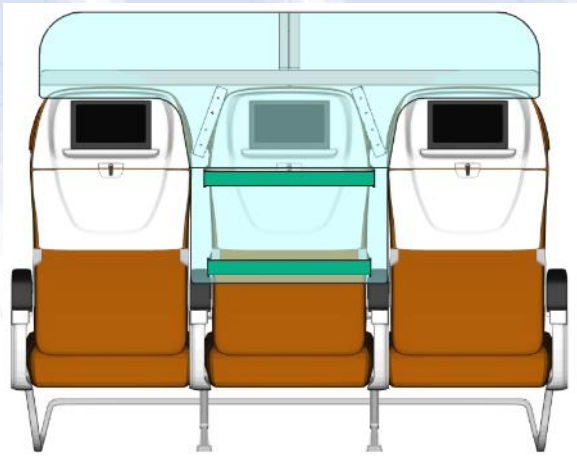



History



➤ June 2019: EarthBay unveiled

➤ December 2019: outbreak of Covid-19



➤ March-April 2020: shutdown of 90% of passenger air traffic

➤ April 2020: start of the research for an unoccupied seat concept

➤ May 2020: Patent pending #FR2004370 and concept unveiled

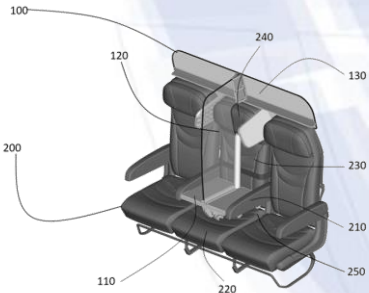

Origin of the name "PlanBay":

'Bay' refers to the initial concept EarthBay which will provide an outstanding flight experience on widebody aircrafts. 'Bay' can refer as well to the unoccupied seat.

On another hand, the entire industry, and the World, is working under a 'Plan B' mode during the outbreak and the recovery.

In French , the pronunciation of the letter 'B' matches the way to pronounce 'Bay'.





Main features

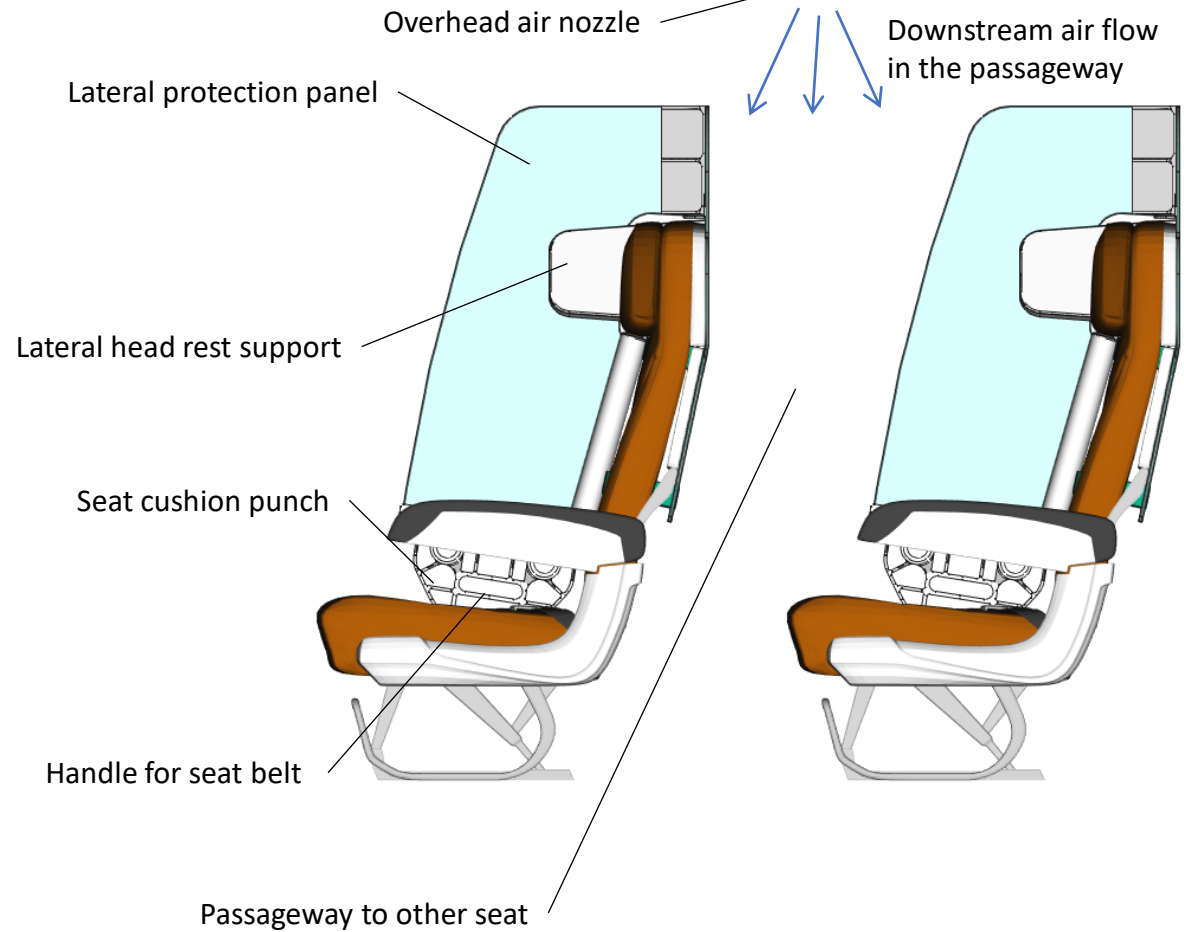
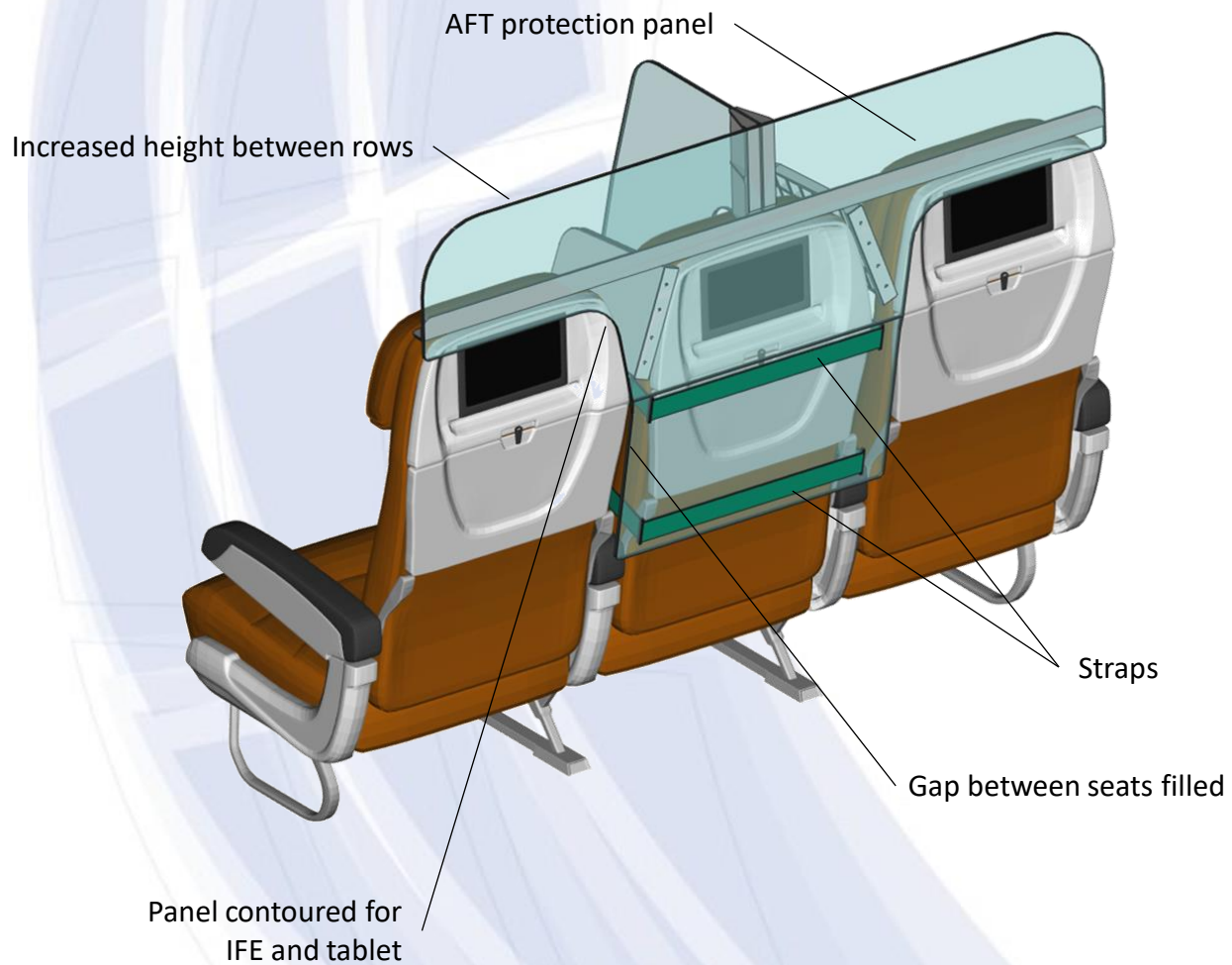

Limitations

- No installation at emergency exist
- No reclining to be consistent with distancing measures, but compensated by a lateral head rest



Embodiment plan

- Adapt drawings to the seat model.
- Obtain approval from authorities as per CS25.785 & CS25.853 (FAR25 or equivalent).
- Production from Plexiglass/Polycarbonate sheets, Alu/plastic profiles, Alu/PEEK 3D printing/machining, elastic straps.
 - Front section
 - Back section
- Installation:
 - Install the Back section.
 - Up the armrest.
 - Install the Front section and fasten seat belt.
 - Lower the armrest till blocking position, the seat cushion is being compressed.
 - Adjust installation and seat belt.
 - Assemble the junction fittings.
 - Control.

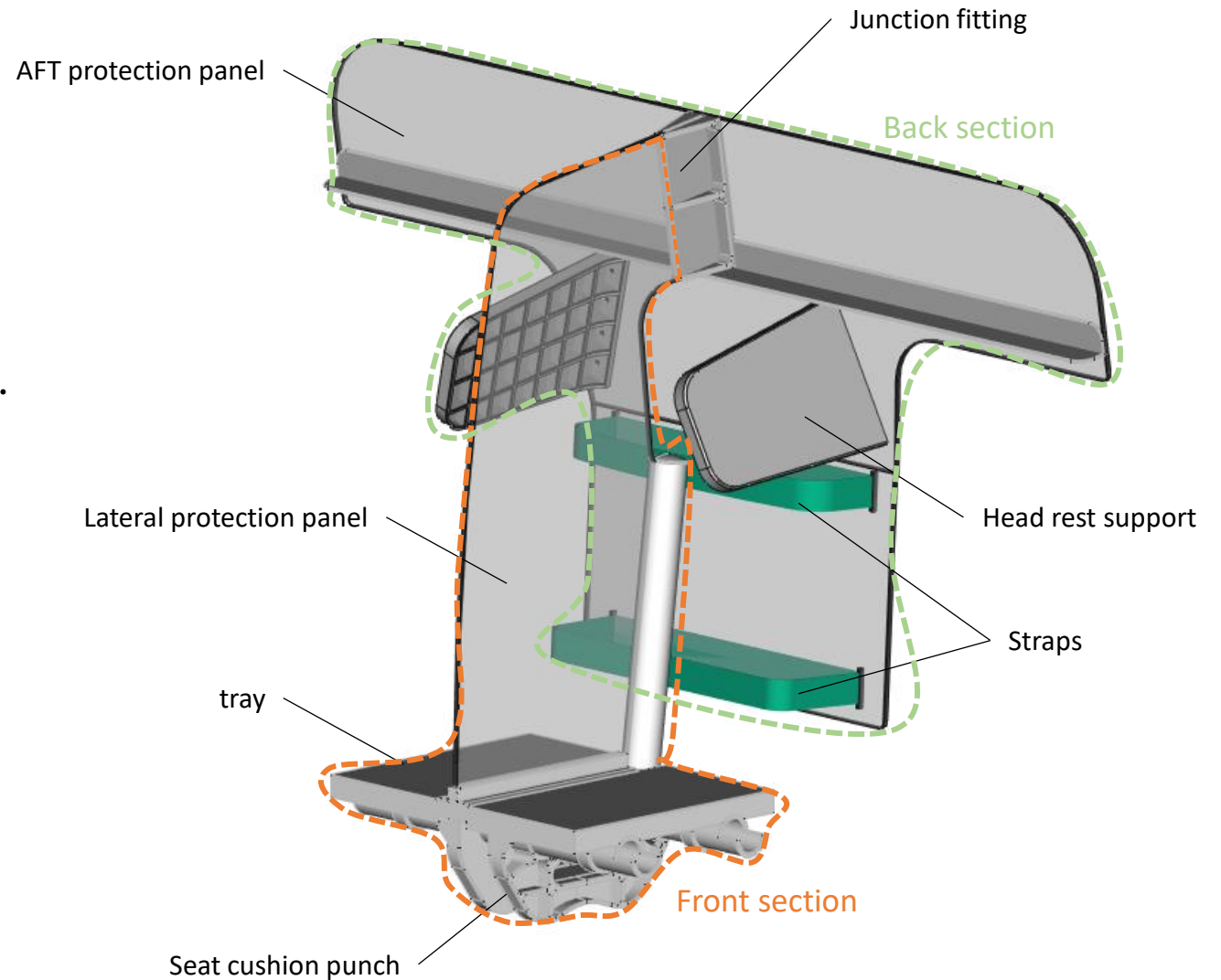



Next steps

- Obtain Airline/Operator interest for the concept
- Partnership with aircraft interiors suppliers with production, logistic and certification capabilities
- Produce a prototype for the first adopter(s)
- Final design & certification
- Production & Entry Into Service





Thank you !

PLANBAY

by



Florian Barjot
Toulouse area - France

www.earth-bay.com



florian.barjot@earth-bay.com
(+33) 6 13 77 45 49

