

I'm not robot  reCAPTCHA

I am not robot!

Honeywell wifi vision pro 8000 installer setup

Honeywell vision pro 8000 app setup. How to connect honeywell vision pro 8000 to wifi. Honeywell vision pro 8000 will not connect to wifi.

04-18-2020, 02:27 PM #1 Hello, I have a honeywell visionpro 8000 thermostat that won't go into setup mode. The unit is currently showing SCREEN LOCKED. When I press install, it only briefly shows the screen with empty buttons on the bottom where you press the buttons to get into setup mode. Then goes immediately back to normal screen. The problem started when I disconnected the unit from a GE heat pump that hasn't been working for years. Power has not been connected to the heat pump ever since it stopped working. Any advice on troubleshooting this would be appreciated. Regards, LT 04-18-2020, 02:33 PM #2 Unfortunately troubleshooting isn't permitted on this forum. 04-18-2020, 05:24 PM #3 If the thermostat is locked, that means someone put a password on it to prevent access to certain settings. 04-18-2020, 06:35 PM #4 .



Any advice on troubleshooting this would be appreciated. Regards, LT 04-18-2020, 02:33 PM #2 Unfortunately troubleshooting isn't permitted on this forum. 04-18-2020, 05:24 PM #3 If the thermostat is locked, that means someone put a password on it to prevent access to certain settings. 04-18-2020, 06:35 PM #4 .

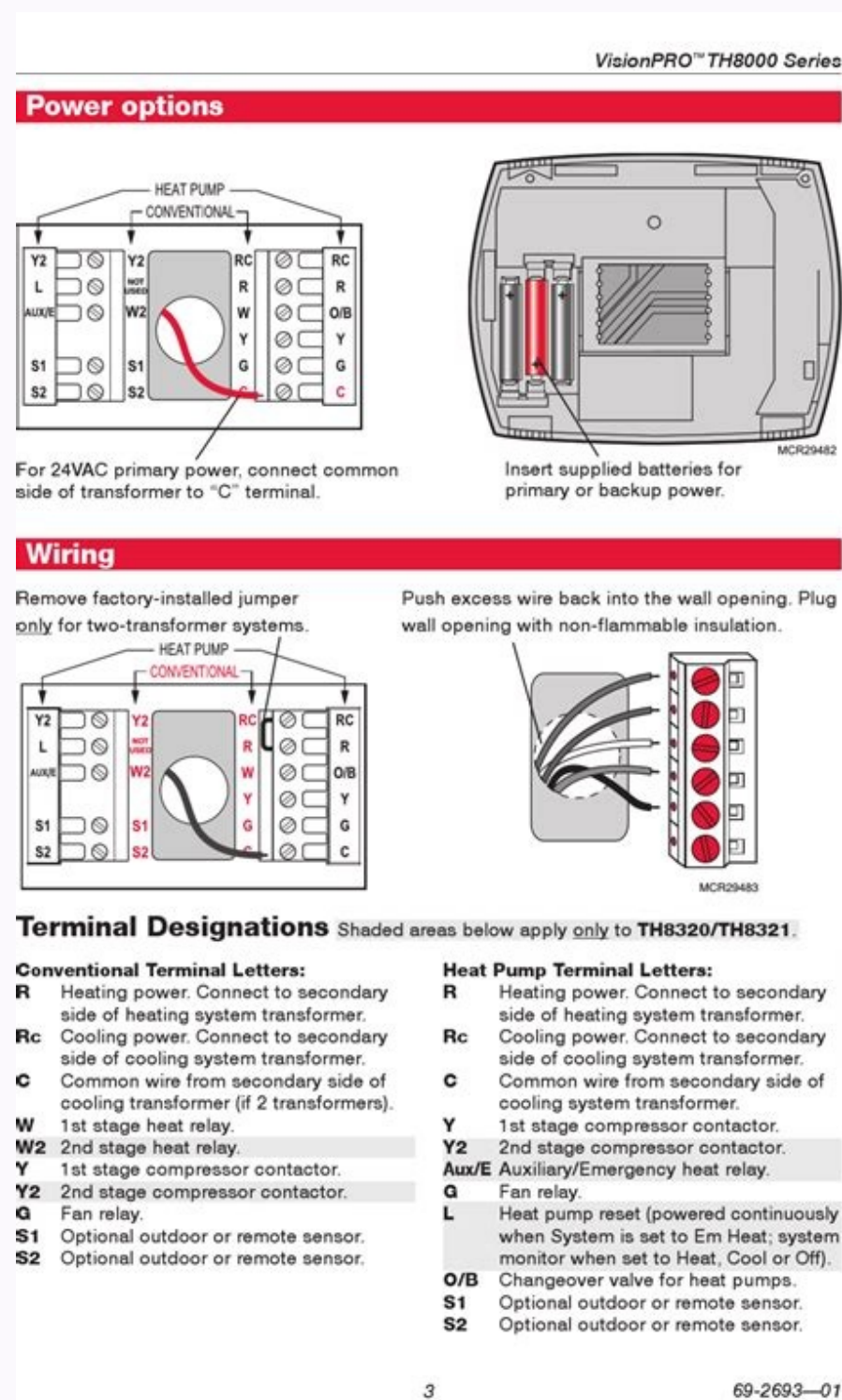

The unit is currently showing SCREEN LOCKED.



Regards, LT 04-18-2020, 02:33 PM #2 Unfortunately troubleshooting isn't permitted on this forum. 04-18-2020, 05:24 PM #3 If the thermostat is locked, that means someone put a password on it to prevent access to certain settings. 04-18-2020, 06:35 PM #4 . I believe you'll want to call a Pro or Honeywell. It's a common issue and there's a way around your problem. ... Do not attempt vast projects with half vast experience and ideas. ... Product Overview Connect to comfort and control with the VisionPRO® 8000 Wi-Fi Programmable Thermostat. Set a schedule for each day of the week and adjust it using the Total Connect Comfort app.

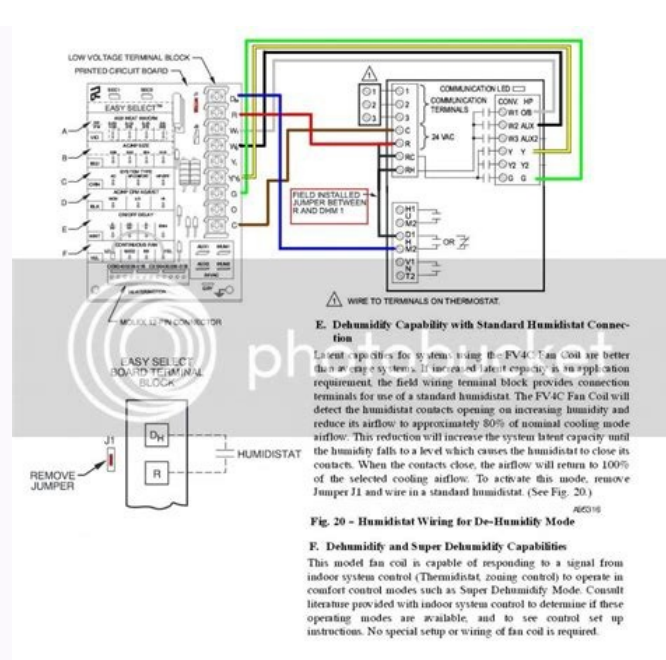

04-18-2020, 05:24 PM #3 If the thermostat is locked, that means someone put a password on it to prevent access to certain settings. 04-18-2020, 06:35 PM #4 . I believe you'll want to call a Pro or Honeywell. It's a common issue and there's a way around your problem. .. Do not attempt vast projects with half vast experience and ideas.



The unit is currently showing SCREEN LOCKED. When I press install, it only briefly shows the screen with empty buttons on the bottom where you press the buttons to get into setup mode. Then goes immediately back to normal screen. The problem started when I disconnected the unit from a GE heat pump that hasn't been working for years. Power has not been connected to the heat pump ever since it stopped working. Any advice on troubleshooting this would be appreciated. Regards, LT 04-18-2020, 02:33 PM #2 Unfortunately troubleshooting isn't permitted on this forum.

04-18-2020, 05:24 PM #3 If the thermostat is locked, that means someone put a password on it to prevent access to certain settings. 04-18-2020, 06:35 PM #4 . I believe you'll want to call a Pro or Honeywell. It's a common issue and there's a way around your problem. .. Do not attempt vast projects with half vast experience and ideas. ... Product Overview Connect to comfort and control with the VisionPRO® 8000 WiFi Programmable Thermostat. Set a schedule for each day of the week and adjust it using the Total Connect Comfort app. When connected to the app, you can control the system remotely and receive alerts for maintenance or extreme temperatures. The VisionPRO® 8000 WiFi thermostat can also control a whole-home humidifier, dehumidifier, or ventilator for fine-tuned comfort. The large touchscreen display is easy to read and shows the status of all equipment controlled by the thermostat. It can also present your dealer information if you need to reach out for service or questions. Take It All With You Gain control over their connected devices from anywhere at any time through the Total Connect® Comfort App. You can monitor and adjust heating and cooling usage, stay on top of indoor humidity levels, and automatically receive email alerts related to safety, comfort and energy. The app works with a wide range of popular connected devices. Learn more One of the Family Love your existing devices? We do, too. Our products, apps and services play well with others so you can make home a little more harmonious. See how we support your home and fit into your life. Features VisionPRO® 8000 WiFi Programmable Thermostat Is Your Home Compatible? Knowing your home's wiring can make a difference. Follow these step-by-step instructions to identify if your current wiring is compatible with this thermostat. Get Started Professional installations gets professional results. Find an authorized professional near you to complete your installation. Compare With Similar Products Press and hold the 'Menu' key for five seconds, and 'ISU' will populate. Then press the 'Select' button. Was this article helpful? Yes No Thanks for your feedback! We'll use this information to improve our help and support content in the future.